

AGITATION EFFICIENCY OF DIFFERENT PHYSICAL SYSTEMS

Joanna Karcz, Jolanta Szoplik, Marta Major-Godlewska*, Magdalena Cudak,
Anna Kielbus-Rapała

West Pomeranian University of Technology in Szczecin, Faculty of Chemical Technology
and Engineering, al. Piastów 42, 71-065 Szczecin, Poland

In memory of Professor Jerzy Bałdyga

Efficiency of agitation was considered for different physical systems on the basis of our own experimental studies on homogenisation, heat and mass transfer as well as gas hold-up. Measurements were performed for different physical systems: Newtonian liquids of low and higher viscosity, pseudoplastic liquid, gas–liquid and gas–solid–liquid systems agitated in vessels of the working volume from 0.02 m³ to 0.2 m³. Agitated vessels of different design were equipped with a high-speed impeller (10 impellers were tested). Comparative analysis of the experimental results proved that energy inputs (power consumption) should be taken into account as a very important factor when agitation efficiency is evaluated in order to select a proper type of equipment. When this factor is neglected in the analysis, intensification of the process can be estimated only.

Keywords: agitated vessel, power consumption, mixing time, heat and mass transfer, gas hold-up

1. INTRODUCTION

Agitation of single and multi-phase systems is widely applied in many industrial processes. The aim of agitation is to reduce in-homogeneities in the physical system, to enhance the process rate or to intensify heat and mass transfer. Different mixing aspects are discussed in depth in the literature (Harnby et al., 1997; Nagata, 1975; Oldshue, 1983; Paul et al., 2004). Many empirical correlations were presented for power consumption (Nagata, 1975; Stręk, 1981), heat transfer (Kuncewicz, 2012; Stręk, 1981) and mass transfer (Harnby et al., 1997), as well as for multiphase systems (Kamieński, 2004; Tatterson, 1991). Recently, experimental studies have been developed on momentum transfer (Cudak et al., 2016), power consumption (Major-Godlewska and Karcz, 2018), heat transfer (Peters et al., 2017; Rosa et al., 2020), multi-phase system production (Cudak, 2016, Cudak et al., 2019; Kielbus-Rapała et al., 2019), gas hold-up (Busciglio et al., 2017; Cudak, 2020; Lee and Dudukovic, 2014) and mass transfer (Kracik et al., 2020; Petricek et al., 2018).

The experimental results of mixing time t_m are presented usually in the form of the dimensionless mixing time $\Theta = n \cdot t_m$ as a function of the Reynolds number and ratio of the impeller to agitated vessel diameters d/D . The results of the heat transfer process are described using Nusselt equation $Nu = (\alpha D/\lambda) =$

* Corresponding author, e-mail: mmajor@zut.edu.pl

<https://journals.pan.pl/cpe>



$CRe^A Pr^B Vi^E$ (Karcz and Major, 2001) or the modified Nusselt equation $Nu = K(Re_{PV})^A Pr^B Vi^E$ (Karcz and Major, 2001), where α denotes the heat transfer coefficient. Volumetric mass transfer coefficients $k_L a$ as a function of the impeller speeds n and gas flow rate V_g characterise mass transfer process in the agitated gas–liquid and gas–solid–liquid systems. Dynamic techniques are widely used as they are fast, experimentally simple and applicable in various systems (Littlejohns and Daugulis, 2007; Ozkan et al., 2000).

Process occurring in the agitated vessel of a given geometry can be intensified in a simple way by the increase of the impeller speed n resulting in the increase of the fluid turbulence. According to the definition of Reynolds number for mixing $Re(= nd^2\rho/\mu)$, the physical properties of the agitated fluid and scale of the agitation (diameter of the impeller) must also be included as important factors affecting the course of the agitation.

The efficiency of agitation determines which energy input is necessary to achieve the desired technological effect. Among the two agitated vessels, this one works more efficiently, in which a required effect is achieved with a lower expenditure of mechanical energy (Stręk, 1981). Therefore, the knowledge of the energy inputs is necessary in order to evaluate the efficiency of momentum, heat or mass transfer in the agitated vessel.

The aim of our study was to evaluate the efficiency of agitation for different geometrical and physical systems on the basis of a very extensive set of experimental results obtained for homogenisation and heat transfer in a liquid phase, as well as for gas hold up and mass transfer process in the coalesce and non-coalesce gas–liquid and gas–solid–liquid systems.

2. MATERIALS AND METHODS

Intensification and efficiency of the agitation processes were analysed on the basis of our own extensive experimental research carried out in the agitated vessels of different geometry for different physical systems. Homogenization of liquid identified by mixing time t_m , heat transfer process described with heat transfer coefficients α , gas-hold up φ for gas-liquid and gas-solid-liquid systems, as well as mass transfer process characterized by volumetric mass transfer coefficient $k_L a$ were considered.

The experiments were performed in the large laboratory scale agitated vessels of inner diameter $D (= 2R)$ filled with Newtonian or non-Newtonian fluid up to height $H = D$. The vessels with (or without) the baffles ($J = 4$; $B/D = 0.1$) were equipped with the high-speed impeller of diameter d , mounted centrally or eccentrically ($e/R \neq 0$) and located at the height $h = d$ from the flat bottom of the vessel. Various types of the impellers of standard geometry differing in the mode of the fluid circulation were used (Table 1): Rushton turbine (RT), Smith turbine (CD 6 impeller), pitched blade turbine PBT ($\beta = 45^\circ$), A 315 and HE 3 impellers, as well as propeller (P). Outer jacket (Fig. 1b) or internal vertical tubular coil (Fig. 1c) were used to heat the agitated liquid. The geometrical and physical systems tested and ranges of the measurements are collected in Table 2.

Measurements of mixing time were carried out using a computer-aided thermal method. Un-baffled agitated vessel of inner diameter $D = 0.7$ m and liquid volume $V = 0.27$ m³ was filled with Newtonian liquid, aqueous solution of molasses, up to height $H = D$. Up-pumping impellers of diameter $d = 0.33D$ (or $0.5D$), working at the axial or mixed flow modes and placed at the distance $h = 0.33D$ from the flat bottom of the vessel, were mounted on the centrally ($e/R = 0$) or eccentrically ($e/R \neq 0$; 0.43; 0.57) located vertical shaft. Axial flow propeller (P) with three blades ($Z = 3$), three- or six-bladed pitched blade turbine (PBT-3; PBT-6) and three bladed PBT of diameter $d = 0.5D$ (PBT-3L) were used to agitate (Table 2).

Table 1. Characteristics of the impellers used in the study

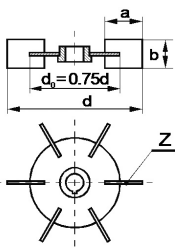
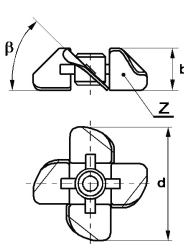
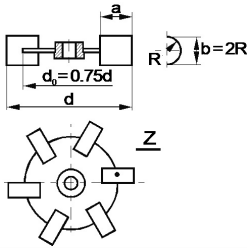
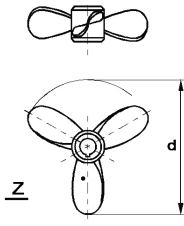
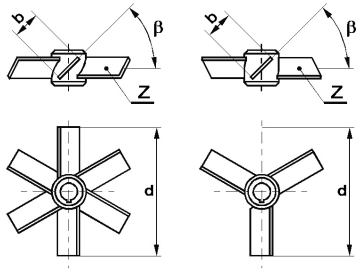
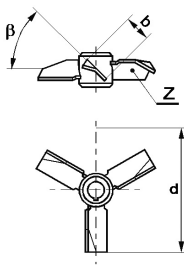
Agitator	Parameters	Agitator	Parameters
	Rushton turbine (RT) $d = 0.33D$ $Z = 6$ $a = 0.25d$ $b = 0.2d$		A 315 $d = 0.33D$ or $d = 0.5D$ $Z = 4$ $b = 0.5d$
	Smith turbine (CD 6) $d = 0.33D$ $Z = 6$ $a = 0.25d$ $b = 0.2d$		Propeller (P) $d = 0.33D$ $Z = 3$ $S = d$ $b = 0.2d$
	Turbine (PBT-6) $d = 0.33D$ $Z = 6$ $\beta = 45^\circ$ $b = 0.2d$ Turbine (PBT-3) $d = 0.33D$ or $d = 0.5D$ $Z = 3$ $\beta = 45^\circ$ $b = 0.2d$		HE 3 $d = 0.33D$ or $d = 0.5D$ $Z = 3$ $b = 0.19d$

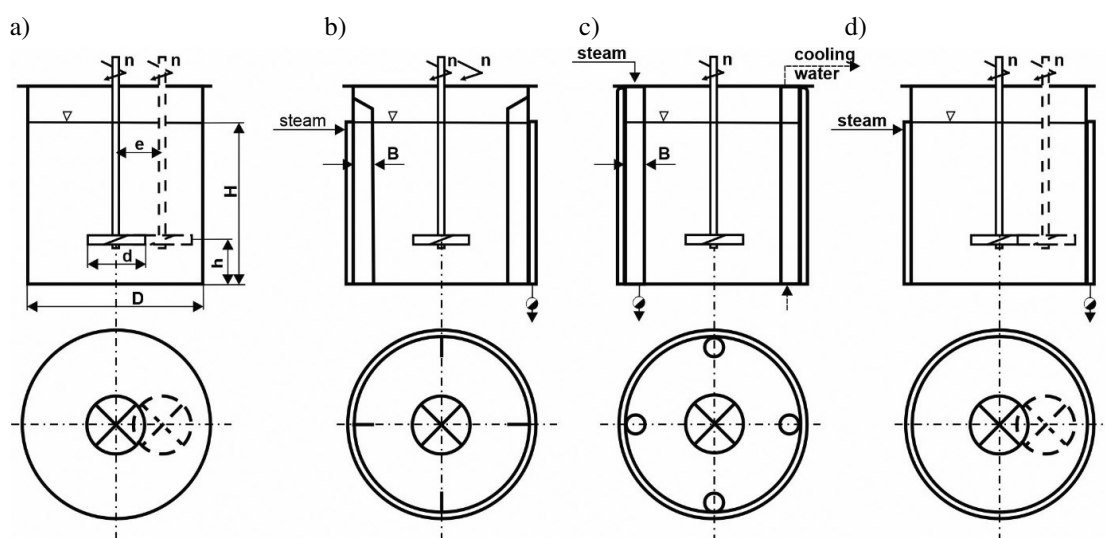

Fig. 1. Types of the agitated vessels used in the study; a) un-baffled vessel with eccentric impeller b) baffled vessel with outer jacket; c) vessel with internal vertical tubular coil; d) un-baffled jacketed vessel

The tracer was a portion ($V_A = 0.7 \text{ dm}^3$) of the same liquid, heated to the temperature 90°C , which was introduced onto the surface of the liquid in the agitated vessel. Mixing time was defined as a period counted from the moment of introducing the tracer into the system until the temperature fluctuations fell below 5%

of the mean value (mixing degree will reach the level of 95%). Experimental set up and method of mixing time measurements are described, in detail, elsewhere (Karcz et al., 2005; Szoplik and Karcz, 2005). An effect of the temperature increase of the agitated liquid and resulting in the change their physical properties, caused by introducing the tracer of higher temperature in a given measurement, was taken into account by using in the quantitative analysis dimensionless Reynolds number for mixing Re instead of impeller speed n only.

Thermal measurements of mean value of heat transfer coefficient α in an agitated vessel with jacket or vertical tubular coil for different geometrical and physical systems (Table 2) were carried out under the steady-state conditions. The heating agent was steam of approximately 102 °C. In detail, measuring methods and experimental set-up for both options of the vessel heating are described elsewhere (Karcz and

Table 2. Range of the study

No	Geometrical system	Physical system	Range of the measurements
1	Homogenisation		
	Agitated vessel of inner diameter $D = 0.7$ m without baffles ($J = 0$); $V = 0.27$ m ³ ; $H/D = 1$; shaft eccentricity $e/R = 0; 0.43; 0.57$; impeller type of diameter $d = 0.33D$; $h = d$ propeller (P \uparrow ; $Z = 3$); PBT \uparrow ($Z = 3$ or 6); PBT-3L \uparrow ($Z = 3$; $d = 0.5D$)	Newtonian liquid (aqueous solution of molasses); density ρ [kg/m ³] $< 1140; 1155 >$; dynamic viscosity μ [mPas] $< 3.3 - 5.3 >$	turbulent liquid flow ($2 \cdot 10^4 < Re < 10^5$)
2	Heat transfer		
	Agitated vessel of inner diameter $D = 0.6$ m with internal tubular coil ($J = 4$; $B/D = 0.1$; $D_c/D = 0.9$); $V = 0.17$ m ³ ; $H/D = 1$; $d/D = 0.33$; propeller (P \uparrow), Rushton turbine (RT); CD 6; HE 3 \downarrow ($d/D = 0.33; 0.5$); A 315 ($d/D = 0.33; 0.5$); $h = d$	non-Newtonian liquid (aqueous solution of CMC); Newtonian liquid (water)	transitional liquid flow ($400 < Re < 10^4$) turbulent liquid flow ($1.5 \cdot 10^5 < Re < 10^6$)
	Jacketed baffled agitated vessel of inner diameter $D = 0.45$ m; $V = 0.072$ m ³ ; $H/D = 1$; $d/D = 0.33$; propeller (P \uparrow), Rushton turbine (RT); HE 3 \downarrow ($d/D = 0.33; 0.5$); A 315 ($d/D = 0.33; 0.5$); with planar baffles ($J = 4$; $B/D = 0.1$); or without baffles and with impeller at vertical central position ($e/R = 0$); or without baffles and with eccentric impeller ($p = 2e/(D-d) = 0.8$); $h = d$	Newtonian liquid (machine oil)	turbulent liquid flow ($10^4 < Re < 7.5 \cdot 10^4$)

Table 2 [cont.]

No	Geometrical system	Physical system	Range of the measurements
3	Gas hold-up in heterogeneous systems		
	Baffled agitated vessel of inner diameter $D = 0.634$ m; $V = 0.2$ m ³ ; $H/D = 1$; $d/D = 0.33$; Rushton turbine (RT); CD 6; A 315; with planar baffles ($J = 4$; $B/D = 0.1$); $h = d$; ring shaped gas sparger	gas-biophase-liquid system (gas: air; biophase: yeast; liquid: aqueous solution of glucose)	5.56×10^{-4} m ³ /s $< V_g < 2.28 \times 10^{-3}$ m ³ /s $1\% < x_1 < 10\%$ $x_2 = 0.5\%$; 1% coalesce three phase system
		gas-liquid system; (gas: air; liquid: aqueous solution of sodium chloride ($c = 0.8$ kmol/m ³)); gas-solid-liquid system; (gas: air; solid: sea sand; liquid: aqueous solution of sodium chloride ($c = 0.4$ kmol/m ³))	0.56×10^{-3} m ³ /s $< V_g < 1.67 \times 10^{-3}$ m ³ /s 0.5 mass.% $< x < 5$ mass.% non-coalesce two- and three phase systems
4	Mass transfer in two and three phase systems		
	Baffled agitated vessel of inner diameter $D = 0.288$ m; $V = 0.02$ m ³ ; $H/D = 1$; $d/D = 0.33$; Rushton turbine (RT); CD 6; A 315; with planar baffles ($J = 4$; $B/D = 0.1$); $h = d$, ring shaped gas sparger	gas-liquid system; (gas: air; liquid: distilled water)	turbulent flow ($5.5 \times 10^4 < Re < 1.68 \times 10^5$) 1.11×10^{-4} m ³ /s $< V_g < 5.56 \times 10^{-4}$ m ³ /s
		gas-solid-liquid system; (gas: air; solid: sea sand particles; liquid: distilled water)	0.5 mass.% $< x < 5$ mass.%; $n > n_{JSG}$ coalesce two- and three phase systems

Cudak, 2002; Karcz and Major, 2001). Power consumption P was measured by means of a strain gauge technique (Major-Godlewska and Karcz, 2018).

The measurements of the gas hold-up φ , defined as the ratio of gas volume V_G to mixture volume V_{G-L} (or V_{G-S-L}), for gas-liquid and gas-solid (biophase)-liquid systems were carried out within the turbulent regime of the liquid flow. The values of φ were determined from the measurements of the levels of the liquid phase H and mixture H_{G-L} (H_{G-S-L}) in the agitated vessel (Cudak, 2016) that were repeated many times.

The measurements of the volumetric mass transfer coefficient k_{La} in a gas-liquid system were performed by means of the unsteady-state gassing-out dynamic method. This method was described in (Kielbus-Rapała, 2006; Kielbus-Rapała and Karcz, 2009) in detail. In this work, the measurements were carried out using the variant of the method in which, at constant values of the agitator speed n and gas flow rates V_g , the kind of gas introduced into the vessel was changed. The gases were air and N₂. Measurements were conducted in a flat-bottomed, fully baffled agitated vessel of inner diameter $D = 0.288$ m, and working liquid volume $V = 0.02$ m³ (H/D). Three different types of single agitator: Rushton or Smith turbines and A 315 impeller with diameter $d = 0.33D$ were used for mixing. All the experiments were carried out at the turbulent regime of the fluid flow (Table 2), at the state of complete dispersion of gas bubbles. In the system with solid phase, agitator speeds higher than the critical agitator speeds n_{JSG} for the three-phase

system were maintained. The n_{JSG} values in the gas–solid–liquid system were evaluated on basis of the Zwietering criterion (Zwietering, 1958).

The change of oxygen concentration dissolved in a liquid was measured by means of fast oxygen probe (galvanic type) coupled with an oxygen meter (CO-551, ELMETRON). The probe was immersed in the liquid and placed at a half distance between the baffles. The $k_L a$ coefficient values were determined from the slope of the plot $\ln[(C^* - C_0)/(C^* - C)] = f(t)$, where t denotes time whilst C^* , C_0 , and C describe saturation concentration of gas in liquid, and concentrations of the gas at time $t = 0$ and t , respectively.

3. RESULTS AND DISCUSSION

3.1. Mixing time

In general, the increase of impeller speeds n affects the intensification of liquid homogenization in the agitated vessel. However, the mixing time t_m also depends on the type of the impeller and geometry of the agitated vessel. This effect is shown in Fig. 2, where dimensionless mixing time $\Theta = nt_m$ as a function of Reynolds number for mixing Re is presented for the centrally ($e/R = 0$) or eccentrically ($e/R = 0.43$) located three bladed propeller (P) and pitched blade turbine (PBT-3). The experimental data show essential influence of the impeller eccentricity e/R on the dimensionless time. Shorter dimensionless time Θ is characteristic for both eccentrically located impellers, propeller (P) and PBT-3, compared to the impellers at vertical central position. These differences are more visible for the propeller. The solid lines in Fig. 2 are an approximation of the experimental data.

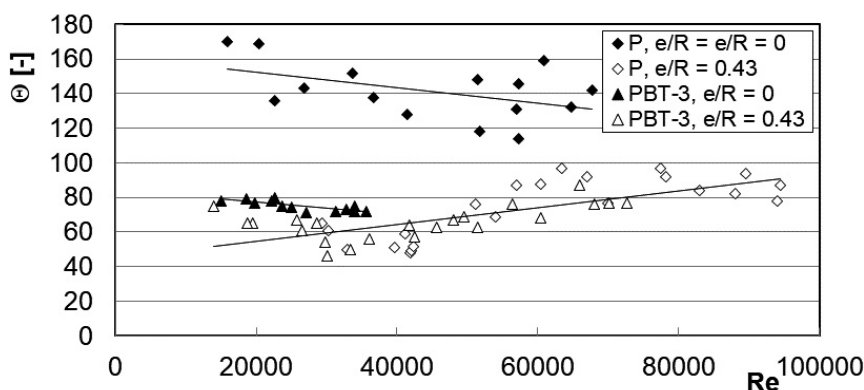

Fig. 2. Dependence of the dimensionless time Θ on the Re number for propeller and three bladed pitched blade turbine PBT-3 at central ($e/R = 0$) and eccentric ($e/R = 0.43$) position

Dimensionless mixing time Θ is compared in Fig. 3 for tested impellers located eccentrically in the agitated vessel and for two different values of Reynolds number Re . The shortest dimensionless time Θ corresponds to three bladed PBT-3 impeller of diameter $d = 0.5D$. The results in Fig. 3 show that the effect of the PBT-3 impeller diameter d is relatively large and the dimensionless time Θ decreases significantly with the increase of the impeller diameter. However, the effect of the number of impeller blades Z of the PBT impeller on the time Θ is much smaller.

Dimensionless time Θ can be applied as intensification criterion of homogenisation process. However, this criterion should be extended in order to evaluate mixing efficiency. Therefore, power input necessary to achieve the assumed degree of mixture homogeneity should be considered in proper agitator selection for liquid homogenization. Both mixing time t_m and power consumption P needed to gain the intended agitation

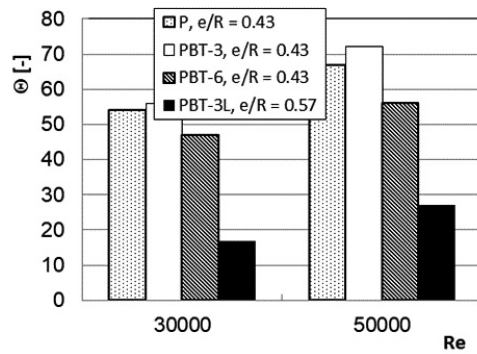

Fig. 3. Comparison of the dimensionless mixing time Θ for eccentrically located impellers and $Re = 30000$ or 50000

effect should be taken into account simultaneously in quantitative analysis. For the set of experimental data, power consumption P [W] was calculated based on the following values of power number Ne (Szoplik, 2004): propeller ($e/R = 0$, $Ne = 0.21$; $e/R = 0.43$, $Ne = 0.28$), pitched blade turbine PBT-3 ($e/R = 0$, $Ne = 0.4$; $e/R = 0.43$, $Ne = 1.0$), PBT-3L ($e/R = 0.57$, $Ne = 1.15$), PBT-6 ($e/R = 0.43$, $Ne = 1.46$). The results of mixing time measurements in the un-baffled agitated vessel with the propeller or PBT-3 impeller in a central or eccentric position are compared in Fig. 4 in the form of dimensional function $t_m = f(\varepsilon)$, where ε [W/kg] – specific energy. The solid lines in Fig. 4 are an approximation of the experimental data. Assuming the constant value of ε [W/kg], the shortest mixing time t_m is obtained for the eccentric ($e/R = 0.43$) propeller and PBT impeller.

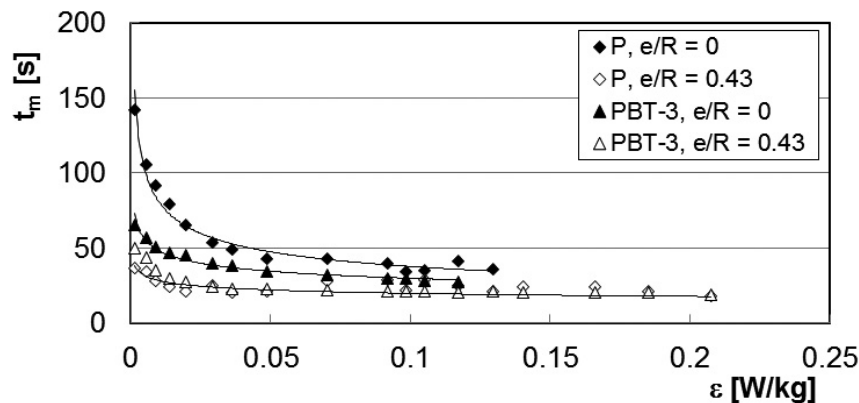

Fig. 4. Dependence of the mixing time t_m on the specific energy ε for the central ($e/R = 0$) or eccentric positions ($e/R = 0.43$) of the propeller and PBT-3

Mixing energy E_m [J], product of power consumption P and mixing time t_m

$$E_m = P \cdot t_m \quad (1)$$

where: $P = Ne \cdot n^3 \cdot d^5 \cdot \rho$

or dimensionless mixing energy E_t (Novak and Rieger, 1994), defined as follows

$$E_t = \frac{P t_m^3}{\rho D^5} = Ne \cdot (n \cdot t_m)^3 \cdot \left(\frac{d}{D}\right)^5 \quad (2)$$

can be considered as useful efficiency criteria to evaluate liquid homogenization. From the point of view of mechanical energy requirement, the best geometrical system is characterized by the lowest energy input expressed by means of E_m or E_t . The values of mixing energy E_m and dimensionless energy E_t are compared in Figs. 5 and 6 for eccentrically located propeller (P) and pitched blade turbines PBT-3, PBT-6 and PBT-3L and given value of Re number. The use of dimensionless energy E_t to compare different

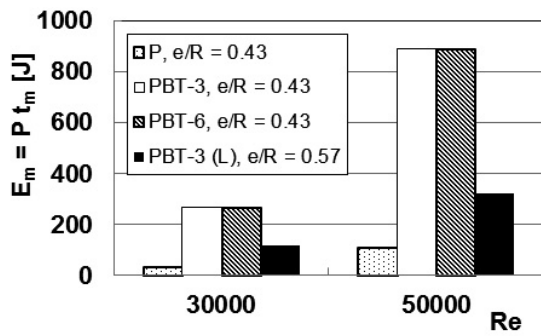

Fig. 5. Comparison of the mixing energy E_m for different impellers located eccentrically in the agitated vessel ($Re = \text{const}$)

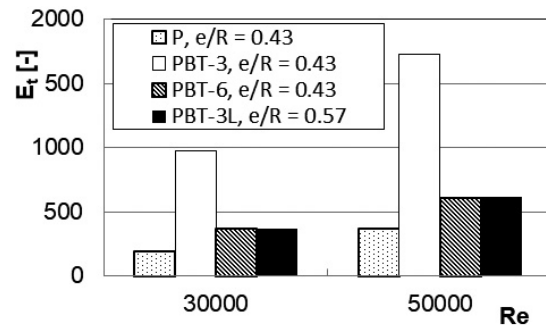

Fig. 6. Comparison of the dimensionless mixing energy E_t for different impellers located eccentrically in the agitated vessel ($Re = \text{const}$)

systems is particularly useful for impellers with a diameter other than $0.33D$ eccentrically located in the tank. The results show that the lowest values of E_m and E_t mixing energy correspond to the propeller located eccentrically ($e/R = 0.43$) in the un-baffled agitated vessel.

Therefore, depending on assumed criteria of process intensification (dimensionless mixing time, Fig. 3) or process efficiency (mixing energy, Figs. 5 and 6), different conclusions concerning the selection of best impeller for liquid homogenisation can be formulated.

3.2. Heat transfer

In Fig. 7, the dependence $Nu/(Pr^{0.33}Vi^{0.14}) = f(Re) = C \cdot Re^A$ is compared for non-Newtonian (aqueous solution of CMC) and Newtonian (water or machine oil with viscosity four times higher than water viscosity at the temperature of 20°C) liquids heated in baffled agitated vessels of inner diameter $D = 0.45$ m or 0.6 m, filled with a liquid up to a height $H = D$. The agitated vessels differed in: a) types of heat transfer surface area (outer jacket ($D = 0.45$ m) or internal tubular coil ($D = 0.6$ m) consisted of four vertical tubes (baffles)); b) shape of four baffles (planar or tubular) of width $B = 0.1D$ arranged at the vessel wall; c) impellers type (radial flow Rushton turbine (RT) or up-pumping axial flow propeller (P) of diameter $d = 0.33D$). The results in Fig. 7 show that much higher intensity of heat transfer process ensures the radial flow Rushton turbine compared to axial flow propeller, regardless of whether it operates in the vessel equipped with jacket or tubular coil. Much higher liquid turbulence is characteristic for Newtonian liquid of low viscosity (water) agitated in the vessel with vertical tubular coil compared to non-Newtonian liquid (CMC solution, in this case apparent viscosity $\mu_{ae} = k(B_1n)^{m-1}$ is applied to calculate of Re number).

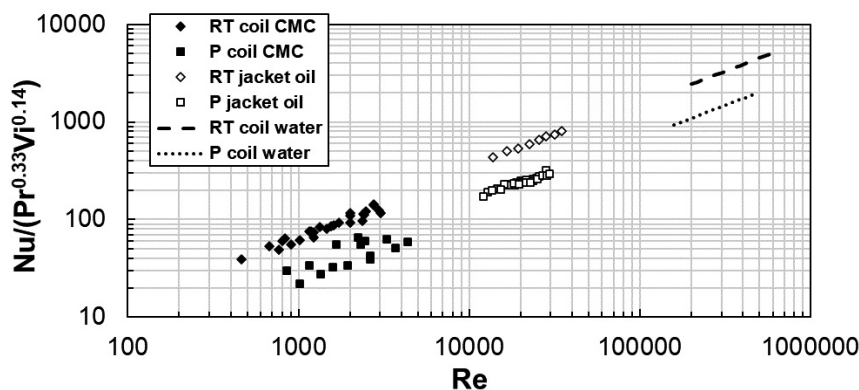

Fig. 7. Dependence $Nu/(Pr^{0.33}Vi^{0.14}) = f(Re)$ for Rushton turbine (RT) and propeller (P) operating in the agitated vessel with jacket or vertical tubular coil; dashed lines – according to data from (Michalska, 2001)

The effects of the impeller diameter d and the mode of liquid circulation imposed by the impeller on the intensity of heat transfer process are presented in Fig. 8 in the form of the $Nu/(Pr^{0.33}Vi^{0.14}) = f(Re)$. The thermal data were obtained for A 315 and HE 3 impellers of diameter $d = 0.33D$ or $0.5D$ used to agitate Newtonian liquid (water or machine oil) in the baffled vessels equipped with the heating surface areas as in Fig. 7. The four-bladed A 315 impeller operates in a mixed flow mode, whereas a down pumping axial flow mode is characteristic for the three-bladed HE 3 impeller. The results in Fig. 8 show that much higher intensity of heat transfer in both agitated vessels (with jacket or tubular vertical coil) is ensured for both liquids with mixed flow A 315 impeller compared to axial flow HE 3 impeller. However, the effect of impeller diameter d on the heat transfer process intensity is relatively small for both tested impellers.

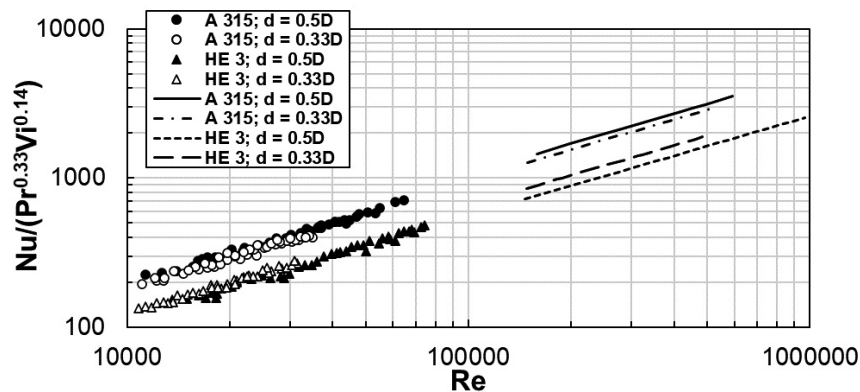

Fig. 8. Dependence $Nu/(Pr^{0.33}Vi^{0.14}) = f(Re)$ for A 315 and HE 3 impellers operating in the agitated vessel with jacket (points, oil) or vertical tubular coil; solid and dashed lines – according to data from (Michalska, 2001)

The effects of the different types of high-speed impellers, used to agitate Newtonian liquid in the baffled ($J = 4$; $B/D = 0.1$), jacketed agitated vessel of inner diameter $D = 0.45$ m, on the intensification of the heat transfer process are presented in Fig. 9. Radial flow sixth-bladed Rushton turbine (RT), mixed flow

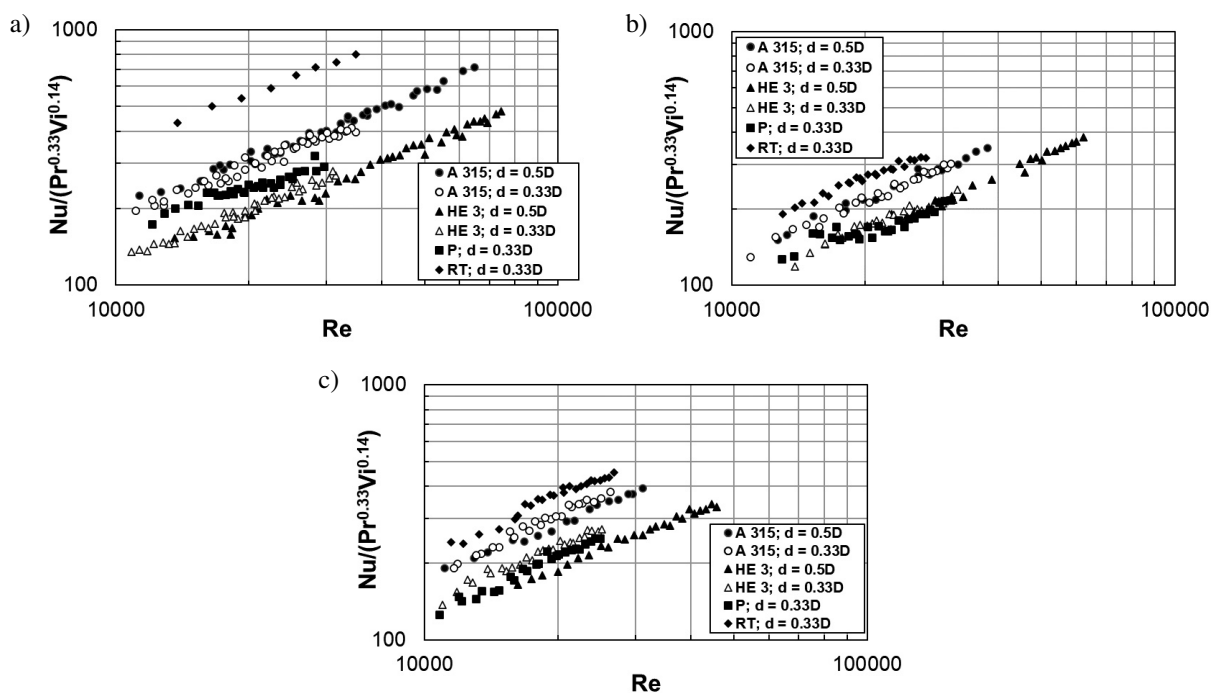

Fig. 9. Dependence $Nu/(Pr^{0.33}Vi^{0.14}) = f(Re)$ for different impellers operating in the agitated vessel with jacket; a) with baffles ($J = 4$; central position of impeller shaft ($p = 0$)); b) without baffles, $p = 0$); c) without baffles, eccentric position of impeller shaft $p = 0.8$

four-bladed A 315 impeller, up-pumping axial flow three-bladed propeller (P) and down-pumping axial flow three-bladed HE 3 impeller are compared. The experimental data show that the heat transfer process depends on the circulation of the liquid formed by the impeller, the radial liquid circulation mode of the impeller enables the most intensive course of the heat transfer, opposite to the down-pumping axial flow imposed by HE 3 impeller (Fig. 9a).

The effect of the planar baffles removal from the jacketed vessel on the heat transfer process for the Newtonian liquid can be analysed comparing the thermal results presented in Fig. 9b, for the agitated vessel without baffles and with centrally located impeller shaft, with the results shown in Fig. 9a for the vessel with four standard planar baffles. In general, the heat transfer process is less intense in the agitated vessel without baffles in comparison with the process occurring in the vessel equipped with baffles. However, the effects of the impeller type and the mode of liquid circulation on the heat transfer are similar to those obtained for the agitated vessel with baffles, i.e. radial flow Rushton turbine gives the best results, whereas the worst ones correspond to axial flow propeller and HE 3 impeller.

The effect of the relocation of the impeller shaft to the eccentric position ($p = 0.8$) in the un-baffled jacketed agitated vessel equipped with different types of high speed impellers on the course of heat transfer process of Newtonian liquid is shown in Fig. 9c. An analysis of the experimental data in Fig. 9c shows that the heat transfer process in the agitated vessel with the eccentric impeller is more intensive than in the un-baffled vessel with the centrally located impeller (Fig. 9b), but this process is less intensive compared to the heat transfer process in the baffled vessel (Fig. 9c).

Examples of heat transfer in the agitated vessel presented in Figs. 7–9 show that the function $Nu/(Pr^{0.33}Vi^{0.14}) = f(Re)$ describes different factors affecting intensification of heat transfer process, namely, type and geometry: of heating surface area, impeller and baffle; presence/or not baffles, shaft eccentricity, mode of liquid circulation generated by the impeller; physical properties of the agitated liquid, etc. However, this correlation does not provide information on what energy inputs are needed in order to achieve required results of agitation. For this reason, the analysis of the heat transfer should be extended to power consumption necessary to determine the efficiency of the process.

Heat transfer efficiency in the agitated vessel can be evaluated using criterion $Nu/(Pr^{0.33}Vi^{0.14}) = f(Re_{P,V}) = K \cdot (Re_{P,V})^{A/3}$, where $Re_{P,V}$ denotes modified Reynolds number defined as follows (Karcz and Major, 2001)

$$Re_{P,V} = \frac{\left(\frac{P}{V}\right) \cdot D^4 \cdot \rho^2}{\mu^3} \quad (3)$$

Experimental dependences $Nu/(Pr^{0.33}Vi^{0.14}) = f(Re_{P,V})$ are presented in Fig. 10 for different geometries of the agitated vessel: with internal tubular coil or outer jacket (Fig. 10a), with outer jacket and: baffles (Fig. 10b), or without baffles (Fig. 10c), or without baffles and with the eccentrically located impeller (Fig. 10d). Comparison of these results with the data given in Figs. 7–9 shows that heat transfer is less sensitive to the changes of the type and geometry of the impeller and baffles when needed power inputs are taken into account in the process analysis. Heat transfer efficiency is very similar for the systems with radial flow CD 6 impeller, axial flow propeller (P) and mixed flow A 315 impeller used to agitate Newtonian and non-Newtonian liquid in the vessel with jacket or tubular coil (Fig. 10a). Similar heat transfer efficiency (Fig. 10d) is characteristic also for the un-baffled jacketed vessel with eccentric high-speed impeller of different type (propeller (P), HE 3, A 315, Rushton turbine (RT)).

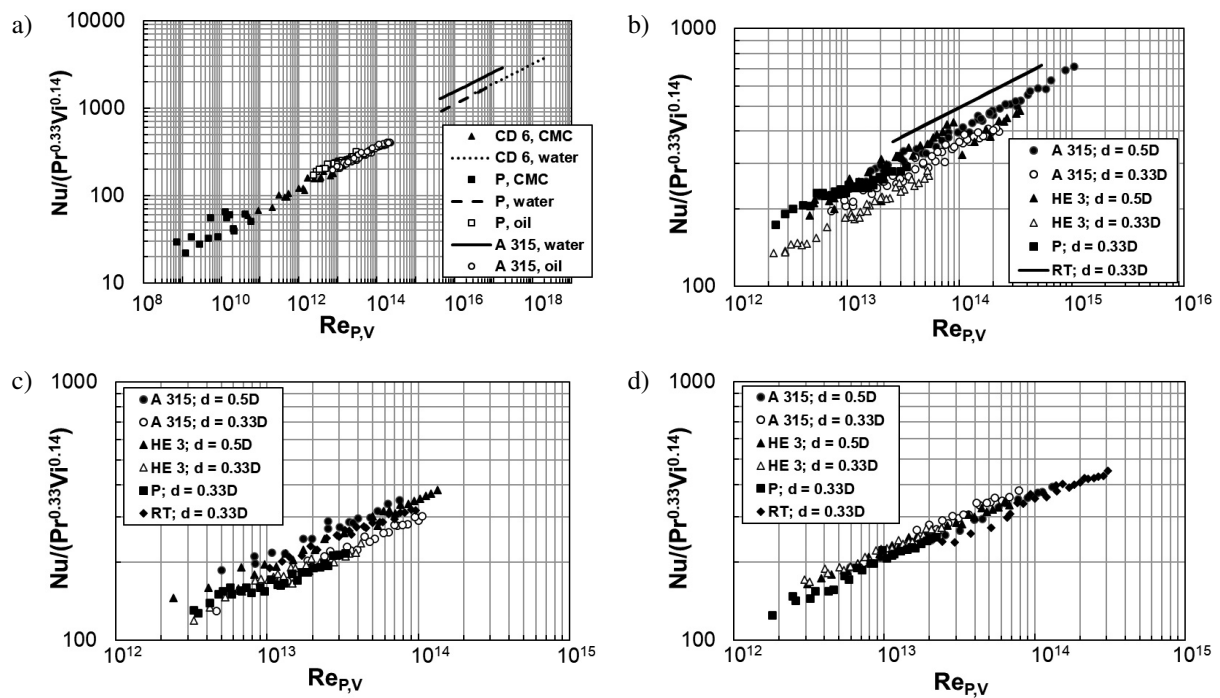

Fig. 10. Dependence $Nu/(Pr^{0.33}Vi^{0.14}) = f(Re_{P,V})$ for different impellers operating in the agitated vessel a) with tubular coil or outer jacketed (solid and dashed lines – according to data from (Michalska, 2001)); b) with jacket and baffles ($J = 4$; central position of impeller shaft ($p = 0$)); c) with jacket and without baffles, $p = 0$); d) with jacket and without baffles, eccentric position of impeller shaft $p = 0.8$

Quantitatively intensification and efficiency of heat transfer process in the agitated vessel can be estimated by analysing coefficients C and K in the dimensionless Nusselt equations, where (Karcz and Major, 2001)

$$K = \left[\frac{C}{\left[Ne \cdot \left(\frac{D}{d} \right) \right]^{A/3}} \right] \quad (4)$$

and Ne denotes power number ($Ne = \text{const}$ within the turbulent range of the liquid flow). The values of coefficients C , K and power number Ne , obtained for agitation of Newtonian liquid in the jacketed vessel equipped with/or without planar baffles and with different high-speed impeller located centrally or eccentrically, are compared in Fig. 11a, b, c. The highest values of coefficient C correspond to the radial flow Rushton turbine (RT) in the baffled vessel (Fig. 11a, $J = 4$; $e/R = 0$), whereas the lowest ones – to the down-pumping axial flow HE 3 impeller with $d = 0.33D$ or $0.5D$). The coefficients C decrease essentially when the baffles are removed from the agitated vessels ($J = 0$; $e/R = 0$). However, the replacement of the impeller shaft into eccentric position affects the enhancement of C value. A similar comparison of power number Ne (power consumption P) shown in Fig. 11b shows the power inputs necessary to reach the assumed intensification of heat transfer process. A very low power number is ascribed to axial flow propeller (P) and HE 3 impeller, whereas the highest value of Ne is characteristic for radial flow Rushton turbine (RT). Both values of C and Ne are used to calculate the K coefficient (Fig. 11c) for different geometrical systems of the jacketed agitated vessel. The best efficiency of the heat transfer process (the highest value of K) corresponds to the baffled jacketed agitated vessel with Rushton turbine (RT), but the systems equipped with the up-pumping axial flow propeller and with the mixed flow A 315 impeller of diameter $d = 0.5D$ work relatively well. Therefore, the extended analysis of the heat transfer process, including necessary energy inputs (Figs. 11b, c), leads to deeper conclusions compared to data shown in Fig. 11a. Efficiency of the heat transfer process of Newtonian (oil, water) or non-Newtonian liquid (aqueous solution of CMC) agitated with the axial flow propeller (P) in the baffled vessel heated by means of outer

jacket or in the un-baffled one heated with the vertical tubular coil ($D_c/D = 0.9$; $J = 4$; $B/D = 0.1$) is compared in Fig. 11d. The results show that the type of heating surface area practically does not affect the heat transfer efficiency for Newtonian liquid. However, slightly lower efficiency corresponds to the heating of the non-Newtonian liquid using tubular coil compared to the jacket.

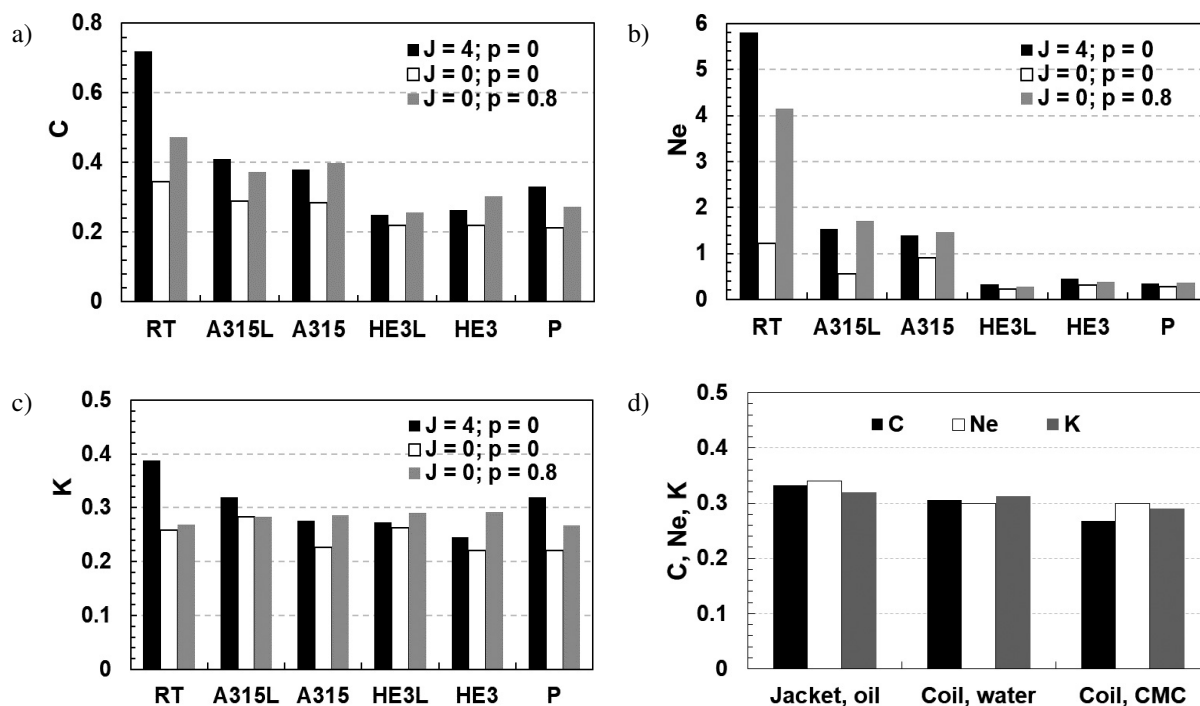

Fig. 11. Comparison of the values C , Ne and K for different geometrical systems (diameter $d = 0.5D$ for A 315L and HE 3L)

3.3. Gas hold-up and mass transfer in heterogeneous systems

In the case of the mechanically agitated gas–liquid and gas–solid (biophase)–liquid systems impeller speed n , gas flow rate V_g and solid concentration, as well as power consumption necessary to produce heterogeneous physical system are taken into account in order to determine gas hold-up φ and mass transfer coefficients.

The results for non-coalescent two and three-phase systems in which the continuous phase was an aqueous solution of electrolyte (sodium chloride with concentration $c = 0.8 \text{ kmol/m}^3$ in gas–liquid and $c = 0.4 \text{ kmol/m}^3$ in gas–solid–liquid system), agitated with a single Rushton turbine (RT), Smith turbine (CD 6) or A 315 impeller in the baffled tank with diameter $D = 0.634 \text{ m}$ are presented in Fig. 12, where data obtained for three different values of gas flow rate V_g are compared as the dependencies of the gas hold-up φ on the impeller speed n or specific energy P_g/V .

According to measurement results (Fig. 12a) in a gas–liquid system, the highest gas hold-up values were obtained for agitation radial Rushton turbine (which generates higher shear stress in the liquid). The effect of the agitator type on φ decreased significantly with the gas quantity in the system, the greatest difference in gas hold-up for RT and CD 6 was observed for the $V_g (= 0.56 \times 10^{-3} \text{ m}^3/\text{s})$. However, when unit power consumption is included in the consideration, both RT and CD 6 work with the same efficiency in the analysed gas–electrolyte system (Fig. 12b). In the three-phase system, definitely higher values of gas–hold up characterise radial turbines (RT or CD 6) compared to A 315 impeller, which generates mixed: axial-radial fluid flow. Results of φ in the function of impeller speed (Fig. 12c) for both radial flow agitators show that for lower gas flow rates Rushton turbine was better for gas dispersion, which results in higher φ

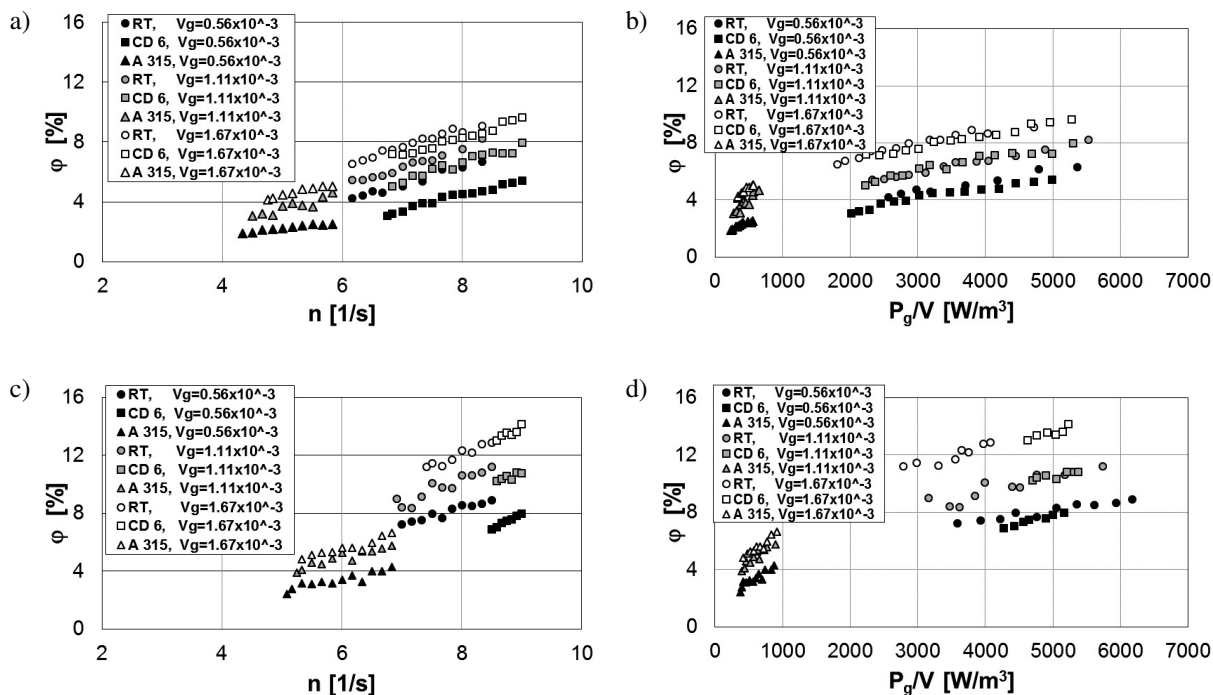

Fig. 12. Comparison of the gas hold-up φ as a function of agitator speed n and P_g/V for RT, CD 6 and A 315 impellers; three different values of V_g , m^3/s ; a, b) for two-phase: air–sodium chloride aqueous solution system ($c = 0.8 \text{ kmol}/\text{m}^3$); c), d) for three-phase: air–sand particles–sodium chloride aqueous solution system ($c = 0.4 \text{ kmol}/\text{m}^3$, $x = 2.5 \text{ mass.}\%$)

(circle points) than CD 6 (square points). The difference between both turbines decreases with the increase of gas flow rate, and at the highest V_g ($= 1.67 \times 10^{-3} \text{ m}^3/\text{s}$), higher gas hold-up values correspond to CD 6. Observing the φ data related to the unit power consumption (Fig. 12d), it can be concluded that for both lower V_g values, the type of the turbine has no influence on φ , when the analysis takes into account power demand (φ values are the same for RT and CD 6).

Another example of the dependence of the gas hold-up φ on the impeller speed n or specific energy P_g/V is illustrated in Fig. 13 where the experimental data are compared for the three phase system (air-biophase ($x_2 = 0.5\%$ yeast)-aqueous solution of glucose of concentration $x_1 = 10\%$) agitated with RT, CD 6 or A 315 impellers in the baffled vessel of diameter $D = 0.634 \text{ m}$. The highest values of the gas hold-up φ correspond to the CD 6 impeller and the lowest ones – to the A 315 impeller when the function $\varphi = f(n)$ is considered (Fig. 13a). However, A 315 impeller works as well as CD 6 impeller (Fig. 13b) when the analysis is based on the dependence $\varphi = f(P_g/V)$.

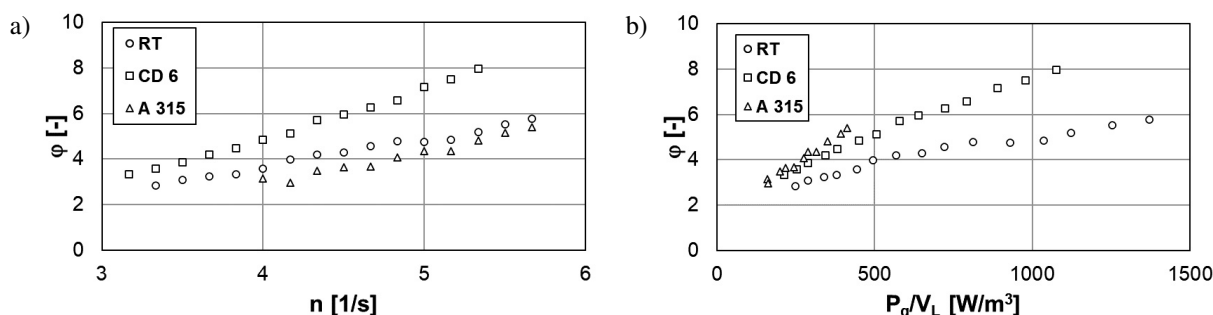

Fig. 13. Comparison of the gas hold-up φ as a function of agitator speed n and P_g/V for RT, CD 6 and A 315 impellers; $V_g = 1.67 \times 10^{-3} \text{ m}^3/\text{s}$; sucrose concentration $x_1 = 10\%$; yeast concentration $x_2 = 0.5\%$

Mechanically agitated vessels are widely used to conduct processes in gas–liquid and gas–solid–liquid systems, e.g. oxidation, fermentation, or wastewater treatment. The oxygen mass transfer between gas and liquid phases is usually described and analysed by means of the volumetric mass transfer coefficient k_{La} . In the gas–liquid and gas–solid–liquid systems, the k_{La} coefficient value is affected by many factors such as geometrical parameters of the vessel, type of the impeller, operating parameters of the process (gas flow rate, impeller speed), properties of the continuous phase (density, viscosity, surface tension, etc.) and also by the type, size and loading of solid particles.

In the whole range of experiment the k_{La} coefficient value increased with the increase of gas flow rate V_g regardless of the type of the system or the impeller type. The effect of agitator speed n was more complex, in the coalescing system the increase of n resulted in the increase in k_{La} coefficient value, while in the non-coalescing system, the value of k_{La} increased with n to a certain value and then decreased with a further increase of impeller speed.

From the designing point of view, the selection of an appropriate agitator is crucial. It should ensure the production of a given heterogeneous system and the appropriate intensity of the conducted process. In the mass transfer investigation, much higher k_{La} values were obtained for the radial flow turbines RT or CD 6, compared to the values obtained using the mixed flow A 315 impeller, as in two- like in three-phase analysed systems. The results of k_{La} for coalescing gas–liquid system agitated with Rushton (circles points) or Smith (square points) turbines are presented in Fig. 14. The comparison of the data, considered in relation to impeller speed n , shows that there is no effect of turbine type on mass transfer process intensity. Generally, both impellers work similarly, only at the lowest V_g , the higher values of mass transfer coefficient characterised Rushton turbine (Fig. 14a). However, when the mass transfer coefficient is compared taking into account P_g/V values (Fig. 14b), the CD 6 (square points), required a lower mixing power, turned out to be better for the implementation of the process. For this impeller even for the lowest V_g , slightly higher mass transfer coefficients were obtained. The differences in k_{La} values for both analysed turbines increased with the increase of aeration rate of the system.

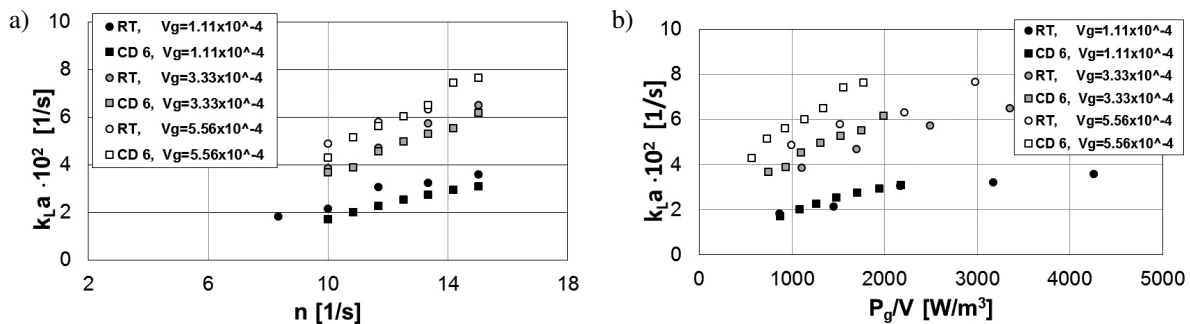

Fig. 14. Comparison of the volumetric mass transfer coefficient k_{La} as a function of agitator speed n and P_g/V for RT and CD 6 working in coalescing air-distilled water system; three different values of V_g , m^3/s

The results of mass transfer process investigation for three-phase system are presented in Fig. 15. The k_{La} data for coalescing system with 2.5 mass% of solids were shown as an example. In the air-sea sand-distilled water system significantly lower mass transfer coefficient values were obtained, when A 315 impeller was used for agitating (triangles points). The effect of turbine type (RT or CD 6) on k_{La} values varies depending on the parameter to which the mass transfer coefficient is related, e.g. for the gas flow rate V_g ($= 3.33 \times 10^{-4} m^3/s$) (gray points in the figure) considering the relation $k_{La} = f(n)$, the values of k_{La} for the RT and CD 6 impeller are the same, slightly higher for RT (circle points) (Fig. 15a). On the other hand, when analysing mass transfer coefficient values in relation to the unit power consumption, better results were obtained using the CD 6 (square points) (Fig. 15b).

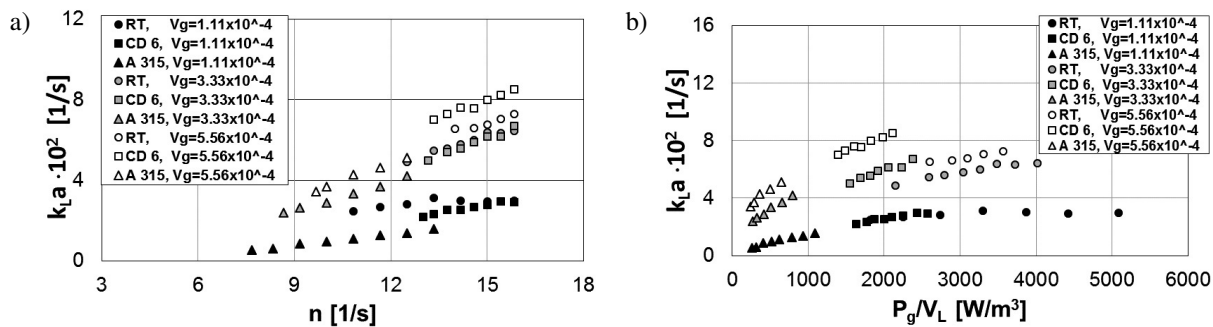

Fig. 15. Comparison of the volumetric mass transfer coefficient k_La as a function of agitator speed n and P_g/V for RT, CD 6 and A 315 impeller working in coalescing air-sea sand-distilled water system; $x = 2.5$ mas.%, three different values of V_g , m^3/s

Summarizing the analysis of experimental dependences for gas hold-up and the volumetric mass transfer coefficient as the functions of the impeller speed or specific power consumption, obtained for coalescing and non-coalescing two- and three-phase systems, the conclusions drawn for the considered physical system on the basis of the relationships $\varphi = f(n)_{V_g=\text{const}}$ or $\varphi = f(P_g/V)_{V_g=\text{const}}$, as well as of the relationships $k_La = f(n)_{V_g=\text{const}}$ or $k_La = f(P_g/V_L)_{V_g=\text{const}}$ are not identical. The correlations $\varphi = f(P_g/V)_{V_g=\text{const}}$ and $k_La = f(P_g/V)_{V_g=\text{const}}$ have a greater informative value compared to the functions $\varphi = f(n)_{V_g=\text{const}}$ and $k_La = f(n)_{V_g=\text{const}}$, because they additionally explain what amount of mechanical energy is necessary to obtain the given value of the gas hold-up and the volumetric mass transfer coefficient.

4. CONCLUSIONS

Different mechanically agitated physical systems (Newtonian liquids of low and higher viscosity, non-Newtonian liquid (pseudoplastic liquid), gas–liquid and gas–solid–liquid systems differing in capability to gas bubble coalesce (coalescing and non-coalescing systems) and in a type of solid phase (biophase) were investigated. Comparative analysis of the experimental results, obtained for different operations with mechanical agitation, proved that:

1. energy inputs (power consumption, specific energy) should be taken into account as very important factors when agitation efficiency is evaluated in order to select a proper type of the agitated vessel for a given mixing operation (homogenization, heat transfer, gas hold-up, mass transfer),
2. when this factor is neglected in the analysis of agitation, intensification of the process can be only estimated.

SYMBOLS

A	exponent at Re number
B	width of the baffle (or coil), m
B	exponent at Pr number
B_1	constant depending on the impeller type
C	constant at Nusselt equation
c	electrolyte concentration, $kmol/m^3$
D	inner diameter of the agitated vessel, m

D_c	coil diameter, m
d	diameter of the impeller, m
E	exponent at simplex viscosity V_i
e	shaft eccentricity
H	liquid height in the vessel, m
h	distance between impeller and bottom of the vessel, m
J	number of baffles (or coil)
K	constant in modified Nusselt equation (definition (4))
k	consistency index, $\text{Pa}\cdot\text{s}^m$
k_{La}	volumetric mass transfer coefficient, 1/s
m	flow index
n	impeller speed, 1/s
n_{JSG}	critical impeller speed for three phase system, 1/s
p	dimensionless eccentricity of impeller shaft, $(= 2e/(D - d))$
P	power consumption, W
P_g/V	specific power consumption for heterogeneous systems, W/m^3
R	radius, m
t_m	mixing time, s
V	volume of the liquid in the vessel, m^3
V_g	gas flow rate, m^3/s
x	solids concentration, %mass.
x_1	sucrose concentration, %mass.
x_2	yeast concentration, %mass.
Z	number of impeller blades

Greek symbols

α	heat transfer coefficient, $\text{W}/\text{m}^2\text{K}$
β	pitch of the impeller blade, deg
ε	specific energy, W/kg
φ	gas hold-up
λ	conductivity, $\text{W}/(\text{mK})$
Θ	dimensionless mixing time
μ	dynamic viscosity of the liquid, $\text{Pa}\cdot\text{s}$
μ_{ae}	apparent dynamic viscosity of the liquid, kg/ms
ρ	density of the liquid, kg/m^3

Dimensionless numbers

$Ne = \frac{P}{n^3 d^5 \rho}$	Newton number (power number)
$Nu = \frac{\alpha D}{\lambda}$	Nusselt number
$Pr = \frac{c_p \mu}{\lambda}$	Prandtl number
$Re = \frac{nd^2 \rho_L}{\mu_L}$	Reynolds number
$Re_{P,V} = \frac{\left(\frac{P}{V}\right) \cdot D^4 \cdot \rho^2}{\mu^3}$	modified Reynolds number
$Vi = \frac{\mu}{\mu_{wall}}$	viscosity simplex

REFERENCES

- Busciglio A., Opletal M., Moucha T., Montante G., Paglianti A., 2017. Measurement of gas hold-up distribution in stirred vessels equipped with pitched blade turbines by means of Electrical Resistance Tomography. *Chem. Eng. Trans.*, 57, 1273–1278. DOI: [10.3303/CET1757213](https://doi.org/10.3303/CET1757213).
- Cudak M., 2016. *Experimental and numerical analysis of transfer processes in a biophase–gas–liquid system in a bioreactor with an impeller* (in Polish). BEL Studio Sp. z o.o., Warszawa.
- Cudak M., 2020. The effect of vessel scale on gas hold-up in gas–liquid systems. *Chem. Process Eng.*, 41, 4, 241–256. DOI: [10.1515/cpe-2016-0005](https://doi.org/10.1515/cpe-2016-0005).
- Cudak M., Galego Zarosa R., Lopez Vazquez I., Karcz J., 2019. An effect of different factors on the production of mechanically agitated multiphase biophase–gas–liquid systems. *Chem. Eng. Trans.*, 74, 1021–1026. DOI: [10.3303/CET1974171](https://doi.org/10.3303/CET1974171).
- Cudak M., Kiełbus-Rapała A., Major-Godlewska M., Karcz J., 2016. Influence of different factors on momentum transfer in mechanically agitated multiphase systems. *Chem. Process Eng.*, 37, 41–53. DOI: [10.1515/cpe-2016-0005](https://doi.org/10.1515/cpe-2016-0005).
- Harnby N., Edwards M.F., Nienow A.W., 1997. *Mixing in the process industries*. Butterworth Co Ltd, London.
- Kamieński J., 2004. *Agitation of multiphase systems* (in Polish), WNT, Warszawa.
- Karcz J., Cudak M., 2002. Efficiency of the heat transfer process in a jacketed agitated vessel equipped with an eccentrically located impeller. *Chem. Pap.*, 56, 6, 382–386.
- Karcz J., Cudak M., Szoplik J., 2005. Stirring of a liquid in a stirred tank with an eccentrically located impeller. *Chem. Eng. Sci.*, 60, 2369–2380. DOI: [10.1016/j.ces.2004.11.018](https://doi.org/10.1016/j.ces.2004.11.018).
- Karcz J., Major M., 2001. Experimental studies of heat transfer in an agitated vessel equipped with vertical tubular coil (in Polish). *Inż. Chem. i Proc.*, 22, 445–459.
- Kiełbus-Rapała A., 2006. *The studies of transfer processes in a mechanically agitated three-phase liquid–gas–solid system* (in Polish). PhD thesis, Technical University of Szczecin, Szczecin.
- Kiełbus-Rapała A., Karcz J., 2009. Influence of suspended solid particles on gas–liquid mass transfer coefficient in a system stirred by double impellers. *Chem. Pap.*, 63, 2, 188–196. DOI: [10.2478/s11696-009-0013-y](https://doi.org/10.2478/s11696-009-0013-y).
- Kiełbus-Rapała A., Rapisarda A., Karcz J., 2019. Experimental analysis of conditions of gas–liquid–floating particles system production in an agitated vessel equipped with two impellers. *Chem. Eng. Trans.*, 74, 1027–1032. DOI: [10.3303/CET1974172](https://doi.org/10.3303/CET1974172).
- Kracik T., Petricek R., Moucha T., 2020. Mass transfer in coalescent batch fermenters with mechanical agitation. *Chem. Eng. Res. Des.*, 160, 587–592. DOI: [10.1016/j.cherd.2020.03.015](https://doi.org/10.1016/j.cherd.2020.03.015).
- Kuncewicz Cz., 2012. *Mixing of high viscosity liquids: Process principles* (in Polish). Łódź University of Technology, Łódź.
- Lee B.W., Dudukovic M.P., 2014. Determination of flow regime and gas hold-up in gas–liquid stirred tanks. *Chem. Eng. Sci.*, 109, 264–275. DOI: [10.1016/j.ces.2014.01.032](https://doi.org/10.1016/j.ces.2014.01.032).
- Littlejohns J.V., Daugulis A.J., 2007. Oxygen transfer in a gas–liquid system containing solids of varying oxygen affinity. *Chem. Eng. J.*, 129, 67–74. DOI: [10.1016/j.cej.2006.11.002](https://doi.org/10.1016/j.cej.2006.11.002).
- Major-Godlewska M., Karcz J., 2018. Power consumption for an agitated vessel equipped with pitched blade turbine and short baffles. *Chem. Pap.*, 72, 1081–1088. DOI: [10.1007/s11696-017-0346-x](https://doi.org/10.1007/s11696-017-0346-x).
- Michalska M., 2001. *Heat transfer in a stirred tank equipped with the vertical tubular coil and rotating agitator* (in Polish). PhD thesis, Technical University of Szczecin, Szczecin.
- Nagata S., 1975. *Mixing. Principles and applications*, Kodansha Ltd. Tokyo.
- Novak V., Rieger F., 1994. Mixing in unbaffled vessel. *8th European Conference on Mixing*, Cambridge, 21–23.09.1994, ICHIME Symposium Series, 136, 511–518.
- Oldshue J.Y., 1983. *Fluid mixing technology*. McGraw-Hill, New York.

- Ozkan O., Calimli A., Berber R., Oguz H., 2000. Effect on inert solid particles at low concentrations on gas–liquid mass transfer in mechanically agitated reactors. *Chem. Eng. Sci.*, 55, 2737–2740. DOI: [10.1016/S0009-2509\(99\)00532-1](https://doi.org/10.1016/S0009-2509(99)00532-1).
- Paul E.L., Atiemo-Obeng V.A., Kresta S.M., 2004. *Handbook of industrial mixing: Science and Practice*. Wiley.
- Petera K., Dostal M., Verisova M., Jirout T., 2017. Heat transfer at the bottom of a cylindrical vessel impinged by a swirling flow from an impeller in a draft tube. *Chem. Biochem. Eng. Q.*, 31, 343–352. DOI: [10.15255/CABEQ.2016.1057](https://doi.org/10.15255/CABEQ.2016.1057).
- Petricek R., Moucha T., Rejl F.J., Valenz L., Haidl J., Cmelikova T., 2018. Volumetric mass transfer coefficient, power input and gas hold-up in viscous liquid in mechanically agitated fermenters. Measurements and scale-up. *Int. J. Heat Mass Transf.*, 124, 1117–1135. DOI: [10.1016/j.ijheatmasstransfer.2018.04.045](https://doi.org/10.1016/j.ijheatmasstransfer.2018.04.045).
- Rosa V.S., Torneiros D.L.M., Maranhão H.W.A., Moraes M.S., Taqueda M.E.S., Paiva J.L., de Moraes Júnior D., 2020. Heat transfer and power consumption of Newtonian and non-Newtonian liquids in stirred tanks with vertical tube baffles. *Appl. Therm. Eng.*, 176, 115355, 1–24. DOI: [10.1016/j.applthermaleng.2020.115355](https://doi.org/10.1016/j.applthermaleng.2020.115355).
- Stręk F., 1981. *Agitation and agitated vessels* (in Polish). WNT, Warszawa.
- Szoplík J., 2004. *The studies of the mixing time in a stirred tank with an eccentrically located impeller* (in Polish). PhD thesis, Technical University of Szczecin, Szczecin.
- Szoplík J., Karcz J., 2005. An efficiency of the liquid homogenization in agitated vessels equipped with off-centred impeller. *Chem. Pap.*, 59, 6a, 373–379.
- Tatterson G.B., 1991. *Fluid mixing and gas dispersion in agitated tanks*. McGraw Hill Inc, Tokyo.
- Zwietering T.N., 1958. Suspending of solids particles in liquid by agitation. *Chem. Eng. Sci.*, 8, 244–253. DOI: [10.1016/0009-2509\(58\)85031-9](https://doi.org/10.1016/0009-2509(58)85031-9).

Received 31 May 2021

Received in revised form 29 June 2021

Accepted 30 June 2021