

Xiao-tao LI
Li-min TAO
Mu JIA

A BAYESIAN NETWORKS APPROACH FOR EVENT TREE TIME-DEPENDENCY ANALYSIS ON PHASED-MISSION SYSTEM

OPARTE NA SIECIACH BAYESOWSKICH PODEJŚCIE DO ANALIZY ZALEŻNOŚCI CZASOWYCHW SYSTEMACH O ZADANIACH OKRESOWYCH WYKORZYSTUJĄCĘ METODĘ DRZEWA ZDARZEŃ

Abstract: Event tree/fault tree (E/FT) method is the most recognized probabilistic risk assessment tool for complex large engineering systems, while its classical formalism most often only considers pivotal events (PEs) being independent or time-independent. However, the practical difficulty regarding phased-mission system (PMS) is that the PEs always modelled by fault trees (FTs) are explicit dependent caused by shared basic events, and phase-dependent when the time interval between PEs is not negligible. In this paper, we combine the Bayesian networks (BN) with the E/FT analysis to figure such types of PMS based on the conditional probability to give expression of the phase-dependency, and further expand it by the dynamic Bayesian networks (DBN) to cope with more complex time-dependency such as functional dependency and spares. Then, two detailed examples are used to demonstrate the application of the proposed approach in complex event tree time-dependency analysis.

Keywords: time-dependency, Bayesian networks, event tree, fault tree, phased-mission system; reliability; risk analysis

Metoda drzewa zdarzeń/drzewa błędów jest najbardziej znanym narzędziem probabilistycznej oceny ryzyka w złożonych, dużych systemach inżynieryjnych; jednak jej klasyczny formalizm najczęściej uwzględnia jedynie niezależne lub niezależne od czasu zdarzenia kluczowe. Praktyczną trudnością występującą w systemach o zadaniach okresowych jest to, że zdarzenia kluczowe, które zazwyczaj przedstawiane są w modelach drzewa błędów jako powiązane zależnościami jawnymi, mającymi związek ze wspólnym zdarzeniem podstawowym, tutaj powiązane są zależnościami czasowymi, jako że przedział czasowy pomiędzy pojedynczymi zdarzeniami kluczowymi nie jest bez znaczenia. W niniejszej pracy, połączyliśmy metodologię sieci Bayesa i analizy drzewa zdarzeń/błędów aby opisać za pomocą pojęcia prawdopodobieństwa warunkowego, zależności czasowe w systemach o zadaniach okresowych, a następnie rozwinęliśmy tę metodę, wykorzystując dynamiczne sieci Bayesa, które pozwalają na analizę bardziej złożonych zależności czasowych, takich jak zależności funkcjonalne i związane z użyciem części zamiennych. W końcowej części pracy przedstawiliśmy dwa szczegółowe przykłady zastosowania proponowanej metody do analizy złożonych zależności czasowych w drzewach zdarzeń.

Słowa kluczowe: zależność czasowa, sieć bayesowska, drzewo błędów, system o zadaniach okresowych, niezawodność, analiza ryzyka.

1. Introduction

Among several techniques available to model sequence and quantify the failure probability in probabilistic risk assessment (PRA), event trees (ETs) are the most recognized methods that develop logical relationship among the events leading to the possible consequences, while fault trees (FTs) best represent the logic corresponding to pivotal events (PEs) and estimate the probabilities [16].

Dependencies in event tree/ fault tree (E/FT) model are frequently encountered, and, if neglected, may result in an error estimation. Hosseini and Takahashi [4] classify dependencies into two categories—implicit and explicit. Explicit dependencies are due to shared basic events (SBEs) such as shared utilities or shared components which appear in more than one corresponding FTs, while the expression of implicit dependencies is a bit vague. Nývlt and Rausand [13] expanded the before-mentioned division to cover more types of dependencies such as common cause failures and cascading effect, and further classified the explicit dependencies with static and dynamic behaviour. Many of the classical methods, such as Binary Decision Diagram

(BDD) [1], Markov Chain (MC) [23] and Petri net [13] have been exploited and developed, in order to deal with different kinds of dependencies in E/FT analysis.

However, in practice of aerospace PRA, such as lunar exploration which has the characteristics of the phased-mission system (PMS), ETs are typically used to portray progressions of phase mission over time, and the time interval between pivotal events (PEs) is not negligible, dependencies therefore become phase-dependency (as a subset of time-dependency in this context), and make the E/FT based reliability and risk analysis more difficult [1, 13].

In ET analysis, not so much work has been done with time-dependency analysis, and the papers cited above are mainly based on the hypothesis about static or time-independent behaviour [1, 4, 13, 23]. PMS reliability attracts substantial attentions, and various techniques have been developed to deal with the phase-dependency. The analytical techniques for the PMS can be classified into two categories: combinatorial models (e.g., mini-components, sum of disjoint phase products, BDD) and state-space transition models (e.g., Markov models, Petri nets) [19, 21]. The combinatorial method is based on the

static PMS, whose assumption is that all the states of all the system components are s-independent. Esary and Ziehams [3] used a set of independent mini-components to replace the component in each phase to deal with the phase-dependency. Over the past decade, researchers have proposed a new algorithms based on BDD for fault tree analysis of PMS by incorporating phase algebra into the generation and traversal of the BDD to deal with phase-dependency [17, 21, 24]. The other method solves the dependency across the phases using state-based approaches, which are flexible and powerful in modelling complex dynamic systems [12, 15].

The above PMS reliability theory is gradually perfecting, but there are still some inadequacies in its application. For the BDD-based fault tree analysis of PMS, the ordering of variables is critical, and, it is not capable of treating other kinds of dependencies of system dynamic behaviour [22]. For MC-based method, it is unreasonable to construct a single Markov model due to the obvious disadvantage that the size would face a state-space explosion problem when modelling large-scale systems [17].

To address the above-mentioned problems, this paper proposes a recently developed methodology based on Bayesian networks (BN). The whole ET with all related FTs is mapped into BNs, and all the FTs resulted BNs are combined by connecting the nodes that represent the same component but belong to different PEs. Thus, the purpose is to demonstrate an alternative perspective on the problem of complex time-dependencies and offer a basis for safety and reliability analysis of PMS.

This paper consists of 5 sections. In the rest sections, we first discuss the dependencies by a demonstrative E/FT model of PMS in Section 2. Section 3 introduces our BN-based approach for E/FT time-dependency analysis. Section 4 describes two examples to demonstrate our proposed approach. Section 5 concludes the paper.

2. Problem statement: time-dependencies in PMS-E/FT model

PMS is subject to multiple, consecutive and non-overlapping phases (time periods) of operation, in which the system configuration, success criteria and component behaviour may vary from phase to phase [19]. To demonstrate the complex dependencies in E/FT model when performing PMS reliability and risk analysis, a simple E/FT model with n phases is discussed as shown in Fig. 1. There are three PEs (means ternate consecutive phases) represented by three fault trees FT_{i-1} , FT_i and FT_{i+1} respectively. Because some basic events (e.g. "C") occur in more than one FT, there is an explicit dependency between PEs.

A problem related to solving explicit dependencies is that the behaviour such as time-independency and time-dependency should be distinguished. The former is a behaviour assumed in most of the papers within a basic assumption is the occurrence/ nonoccurrence of

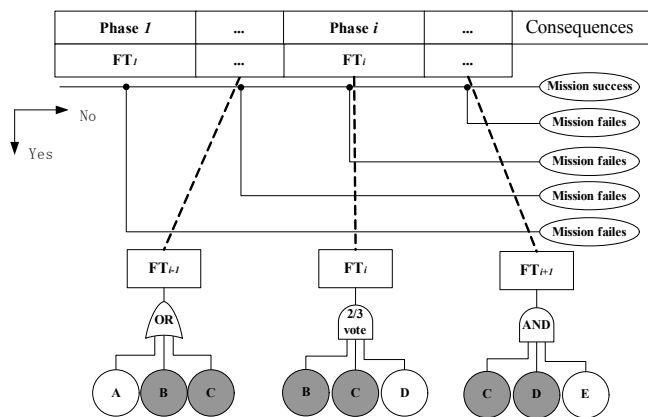

Fig. 1. E/FT synthetical model of phased-mission system

the SBE is the same in every associated FT [1, 4, 13, 23], which means that $C \cdot \bar{C}$ and $\bar{C} \cdot C$ are always impossible to occur and should be neglected.

However, it is not realistic especially when E/FT are typically used to portray the phases' evolution over time. The time and the order of events are critical for the occurrence or not of consequences. The sequences such as $C \cdot \bar{C}$ and $\bar{C} \cdot C$ always occur in these situations as follow:

- (1) When an event tree has been done regarding PMS such as space exploration, the component "C" may work in the previous phase, but fail in the subsequent phase. Therefore, the sequence $C \cdot \bar{C}$ should be taken into account.
- (2) If components are repairable, they can be repaired once the failure occurs during test or work. It means that the sequence $\bar{C} \cdot C$ comes true and should be taken into account.

This dynamic behaviour is closer to reality, but it is also more complicated to model, and the painful aspect is that the basic event probability may change with time. The BDD-based method and state-based method use phase algebra and time dependent rate respectively to deal with the dependency across phases. However, these methods have to confront various degrees of problem with the increase of phases number. In the next section, we will introduce a new approach based on Bayesian networks to model the PMS, and show how to use conditional probability to give expression of the phase-dependency, and further expand the model by the dynamic Bayesian networks (DBN) to cope with more complex time-dependency.

3. Method Description: Modelling time-dependencies in E/FT

3.1. Introduction of BN and DBN

A BN is a graphical inference technique and it's defined by two components: qualitative structure and quantitative parameters. The qualitative part is a directed acyclic graph comprised of nodes and arcs in which the nodes represent Random Variables (RVs) and the arcs symbolize dependencies or cause effect relationships among the RVs. The quantitative part is the conditional probabilistic table (CPT), which presents the quantitative relations between each node and its parents [25].

Benefiting from the modelling advantages, BN is a powerful tool for global systems estimation and can better address some aspects such as multi-state, failures' dependencies, coverage factors, etc. [9], and the unique bidirectional inference mechanism which can be used either to predict the probability or to update the probability of known variables as well as diagnostic [8]. In recent years, BNs have become popular as a robust alternative to most classical methods such as FT [2, 5], ET [10], Bow-tie(BT) [6] etc. In order to represent temporal dependencies, the time-dependency of some random variables that follows a Markov process can be integrated into a dynamic BN. Montani et al. [11] developed the RADYBAN software for converting dynamic FT into a 2-time-slice dynamic BN. Their work was further developed by Portinale et al. [14], enabling the modelling of repair systems by introducing the repair box gate. Weber et al. [20] gave an exhaustive review of BN application and showed its obvious superiority over classical methods in terms of modelling and analysis capabilities. However, details of proposed combination of E/FT with BN for the PMS reliability and risk analysis are not given.

3.2. Translating E/FT to a single BN

3.2.1. Translating PMS-ET into PMS-BN

In practice of a simple PMS, ET is used to model the mission using ordinal linked phase-PEs with a single entry point. Since the system mission will fail if any phase fails, the success of the current mission is conditioned on that of the previous mission and the system survival of current individual phase supporting subsystem (IPSS), which is always represented by a corresponding FT in E/FT model. The logical relationships of the overall mission success criteria are easily presented by the conditional probability as shown in Eq.(1).

$$P(PMS(i)=0 | PMS(i-1)=0, IPSS(i)=0)=1$$

$$P(PMS(i)=0 | else)=0 \tag{1}$$

Where, PMS_i and $IPSS_i$ respectively symbolize the state of i^{th} PMS and IPSS. The number 0 represents the success, and number 1 represents the failure. Different from the mapping rules of ET according to [10], the PMS-ET is translated into corresponding BN as shown in Fig. 2.

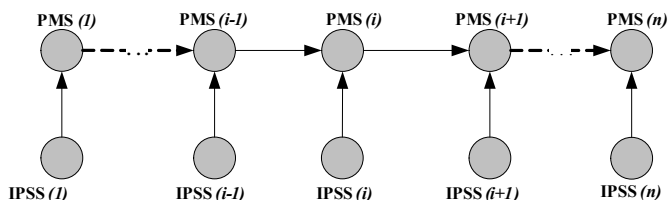

Fig. 2. A Bayesian network representing the Event Tree

3.2.2. Translating FT into corresponding BN

The IPSS is modelled by the corresponding FT, and Fig. 3 illustrates a simplified process of FT 2/3vote gate being converted to the BN, the primary events, intermediate events, and the top event of FT are represented as IPSS node, intermediate node, and leaf node in the corresponding BN, and the CPTs of the IPSS nodes is developed according to the type of logic gate. More basic gates mapping cases and mapping rules can be seen in the work of Bobbio et.al. [2] and Khakzad et.al. [5].

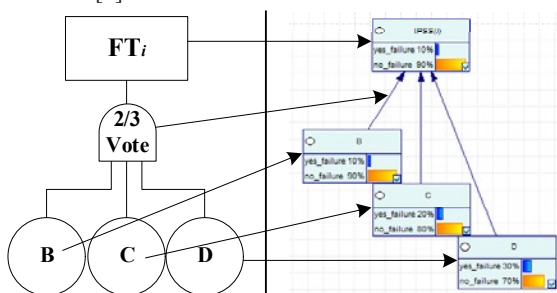

Fig. 3. The 2/3vote-gate converted to BN represented by GeNIe

3.2.3. Incorporating BN

After the equivalent the corresponding BNs of the FTs are developed, they are added into Fig. 2 to construct an integrated BN model via the following two steps: first, incorporate IPSS nodes in Fig.2 with corresponding nodes of the phase-FTs top events; second, add the direct arc to connect the SBE-nodes that represent the same components but belong to different IPSS-BNs.

A three-level hierarchical PMS-BN model which can be equivalent to the PMS-E/FT in Fig.1 is developed and illustrated in Fig.4.

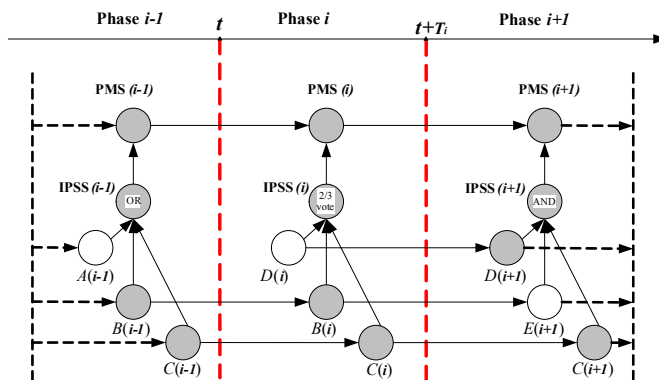

Fig. 4. BN of Fig. 1 representing the PMS-E/FT with phase-dependent

The three levels respectively represent the entire mission states, the reliability of IPSS and the component states. The phase-dependency is defined by the connection of the nodes in the first level and shared nodes of adjacent phases in the third level. The CPTs of the basic events nodes can be computed as follows.

The basic event “C” is taken as an example and supposed to have functioned in all the previous phases. According to the total probability law, the failure function of “C” in the end of phase i is given by

$$P(C_i = 1) = \sum_{j=0,1} P(C_{i-1} = j)P(C_i = 1 | C_{i-1} = j) \tag{2}$$

Where, C_{i-1} and C_i respectively symbolize the random states of “C” at the end of $i-1^{th}$ and i^{th} phase, and j denotes the states of the component. Considering the component is non-repairable, once “C” fails in phase $i-1$, it will maintain its status in phase i , which means

$$P(C_i = 1 | C_{i-1} = 1)=1 \tag{3}$$

$$P(C_i = 0 | C_{i-1} = 1)=0 \tag{4}$$

Substituting Eq.(3) and (4) into (2), thus,

$$P(C_i = 1 | C_{i-1} = 0) = \frac{P(C_i = 1) - P(C_{i-1} = 1)}{P(C_{i-1} = 0)} = \frac{\int_t^{t+T_i} f_{C_i}(\tau) d\tau}{1 - \int_{t-T_{i-1}}^t f_{C_i}(\tau) d\tau} = F_{C_i} \tag{5}$$

$$P(C_i = 0 | C_{i-1} = 0) = \frac{P(C_i = 0)}{P(C_{i-1} = 0)} = \frac{1 - \int_t^{t+T_i} f(\tau) d\tau}{1 - \int_{t-T_{i-1}}^t f(\tau) d\tau} = 1 - F_{C_i} \tag{6}$$

Where, $f_{C_i}(t)$ is the failure density function of “C” in the phase i ; T_i is the duration of phase i ; F_{C_i} presents the component cumulative failure probabilities at the end of phase i , which equals to the conditional failure probability of mini-component given by [3, 24].

If the failure rate of “C” is exponentially distributed, Eq. (5) and (6) can be calculated as:

$$P(C_i = 1 | C_{i-1} = 0) = 1 - e^{-\lambda(T_i)} \tag{7}$$

$$P(C_i = 0 | C_{i-1} = 0) = e^{-\lambda(T_i)} \tag{8}$$

3.3. Extending more complex time dependencies by dynamic BN

If the IPSS exhibits dynamic interactions between components and is modelled by a dynamic fault tree (DFT), it makes the PMS analysis more complex. In this section, we introduce the DBN with further expansion to consider more complex time-dependency.

3.3.1. Translating DFT into corresponding DBN

Dynamic BN extend the BN formalism by providing an explicit discrete temporal dimension. Fig. 5 illustrates a DFT functional dependency (FDEP) gate converted to the IPSS-DBN, the CPTs of the IPSS node is developed according to the type of gate. More basic dynamic gates mapping cases and mapping rules can be seen in the work of Montani et.al. [11].

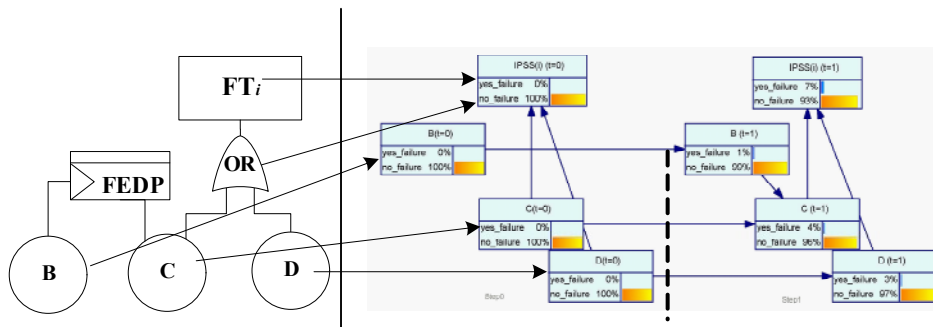

Fig. 5. The FDEP-gate converted to DBN represented by GeNIe

3.3.2. Incorporating DBN

The adjacent phases (e.g. phase $i-1$ and phase i) are two consecutive and non-overlapping phases, therefore the initial probability in phase i should be equal to the end probability in phase $i-1$ for each state. The PMS time line is partitioned into a finite number of time instants (e.g. $t-1, t, t+1$), and, the n mission phases can be treated as $\sum N_i (i=1,2,...,n)$ smaller phases. The difference is that identical BN structures are generated for each time instantly during an individual phase merely, while different BN structures occur across the phase. The PMS-DBN model which can be equivalent to the PMS-E/FT in Fig. 1 is developed and illustrated in Fig. 6.

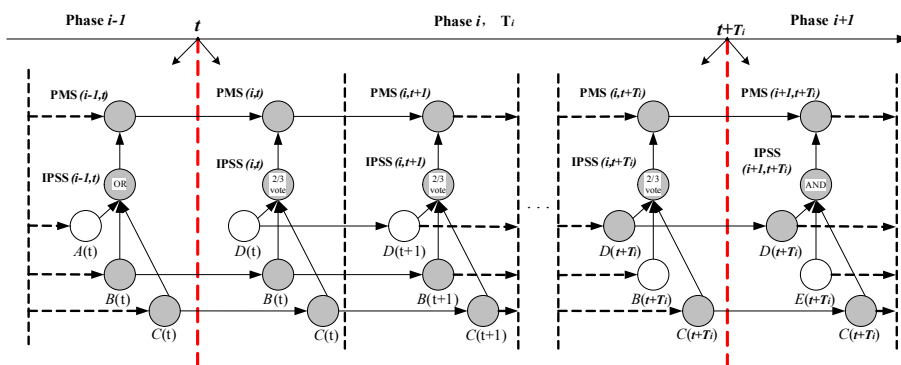

Fig. 6. DBN of Fig. 1 show the PMS-E/FT with time-dependent behaviour

The relationships between basic events in an individual phase at successive time steps are represented by inter-slice arcs, $C_i(t) \rightarrow C_i(t + \Delta t)$, and the relationships of SBEs between adjacent phases are represented by cross-phase arcs, $C_{i-1}(t) \rightarrow C_i(t)$. The same procedure in section 3.2.3 may be easily adapted to obtain the CPTs in PMS-DBN model, as shown in Table 1.

Table1. Conditional probability table for node "C"

$P\{C_i(t) C_{i-1}(t)\}$	$C_{i-1}(t)$		
	0	1	
$C_i(t)$	0	1	0
	1	0	1

$P\{C_i(t+1) C_i(t)\}$	$C_i(t)$		
	0	1	
$C_i(t+1)$	0	$e^{-\lambda\Delta t}$	0
	1	$1 - e^{-\lambda\Delta t}$	1

3.4. Algorithm summary

Based on the above discussion, we depict our approach of combination of E/FT with BN for modelling and analysing the time-dependency with a 5-step procedure as follows:

- 1) Build the E/FT or E/DFT model to express the PMS for reliability or risk analysis.
- 2) Transform ET into the BN mainly based on the work of section 3.2.1.
- 3) Transform FT/DFT into the corresponding BN/DBN according to the work of section 3.2.1 and 3.3.1.
- 4) Incorporate IPSS nodes with the top nodes of corresponding BN, and add the direct arc to connect the shared nodes of adjacent phases that represent the phase-dependency, and The CPTs between two time slices are subsequently established.
- 5) Finally, the whole BNs are equally able to analyse the reliability and safety of the PMS system based on the mature reasoning arithmetic of commercial software.

4. Method application

4.1. Case 1: A simple static PMS

In this section, we apply our approach to a simple example with 2 phases and 3 components (A, B, C), and the E/FT model of system configurations in two phases are shown in Fig. 7. The system parameters are given in table2.

Fig.8 is the PMS-BN model of the example system shown in Fig.7 using GeNIe 2.0 (<http://genie.sis.pitt.edu>), then the nodes conditional probabilities can be calculated using Eq. (1)~(8). The whole PMS reliability is 0.775584, which is consistent with that using of the BDD-based method according to the reference[18].

4.2. Case 2: Auxiliary Power Unit (APU)

4.2.1. Example description and preliminary analysis

The APU as a safety-critical system is used to generate power to drive hydraulic pumps that produce pressure for the orbiter's hydraulic system [22]. The orbiter is equipped with three hydraulic systems to supply redundant power to all hydraulically driven components. Each

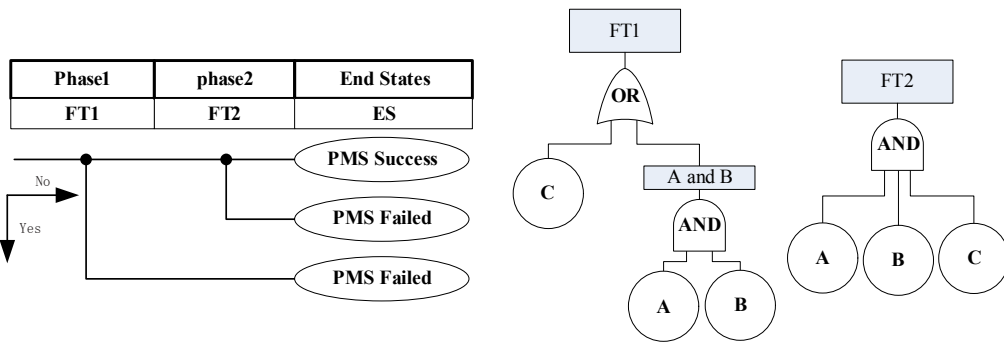

Fig. 7. A simple PMS-E/FT model

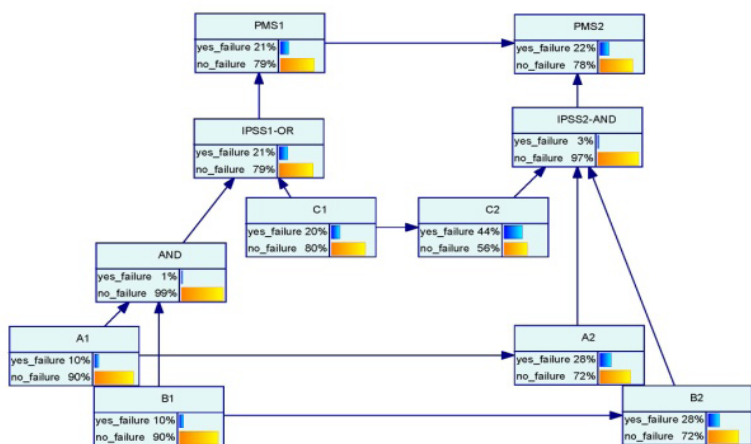

Fig. 8. BN of the PMS-E/FT shown in Fig. 7 by GeNIe

Table 2. Component failure probabilities in each phase

Component probability	A	B	C
phase1	0.1	0.1	0.2
phase2	0.2	0.2	0.3

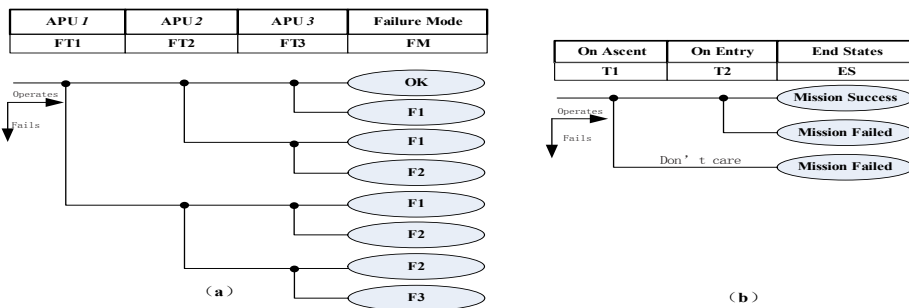

Fig. 9. Scenario model of APU by Two event trees

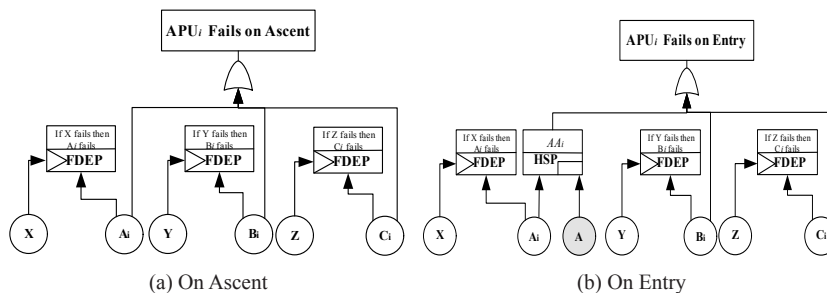
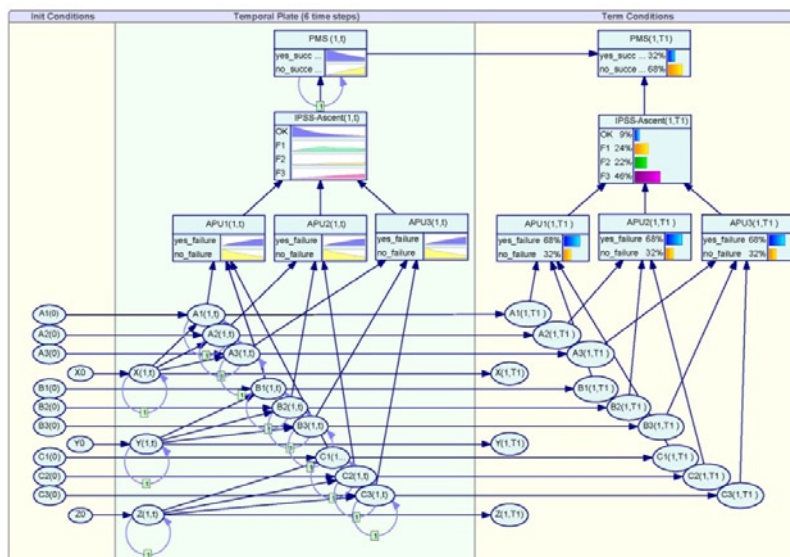
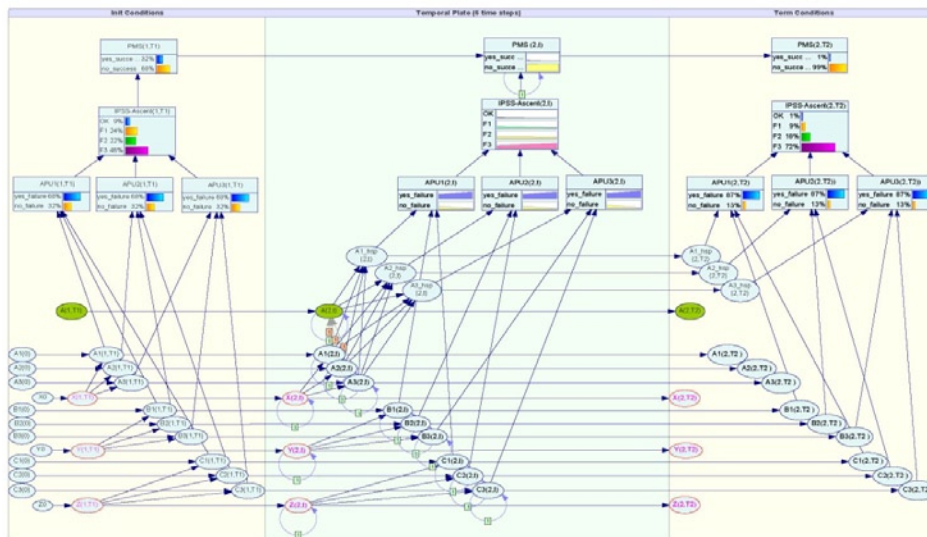

Fig. 10. DFTs of APUi in two phases



(a). On Ascent phase



(b). On Entry phase

Fig. 11. DBN for both phases of APU using GeNIe

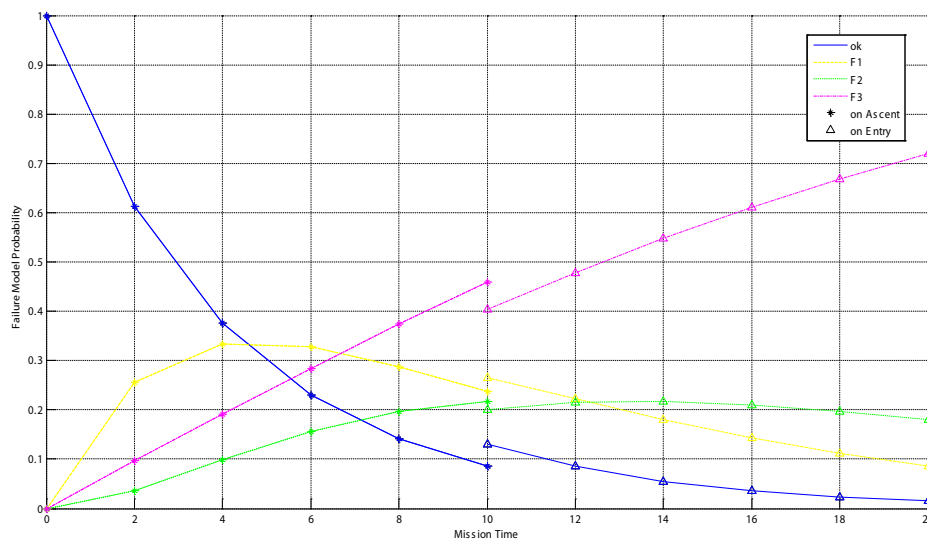

Fig. 12. The failure mode probability of APU system for both phases vs. mission time

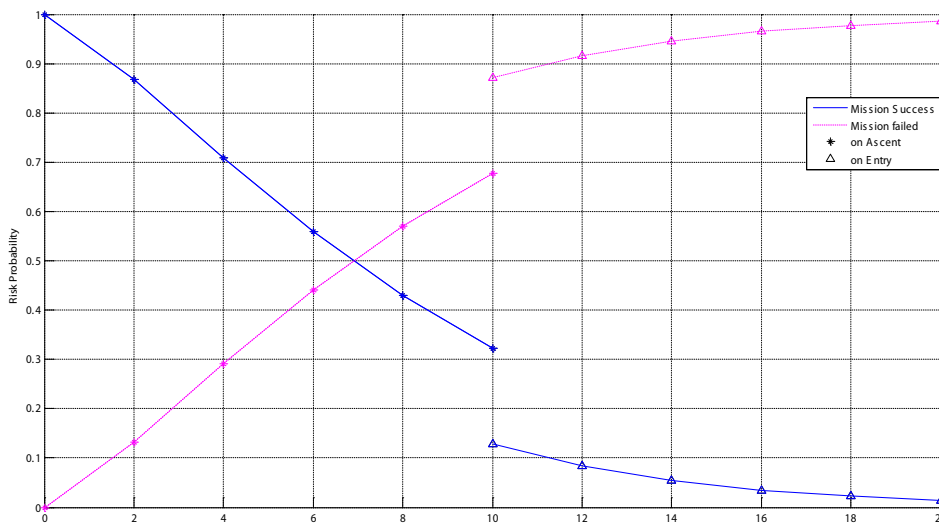

Fig. 13. The risk probability of mission for both phases vs. mission time

system is divided into three subsystems. Since the APU is to serve as an integrating platform for the other two subsystems, the single hydraulic system can be modeled as an APU for ease of presentation.

The system failure mode criteria is defined as such that (1) no loss of any APU unit is regarded as mode OK, (2) loss of any single APU is considered as failure mode F1, (3) loss of any two APUs is failure mode F2, and the worst case (4) loss of all three APUs is failure mode F3. Such accident scenario can be modelled using an ET, as shown in Fig. 9(a).

In this case study, the mission of APU system was simplified into two phases for operation: on Ascent and on Entry. The difference between these two phases is that the APU control spare, denoted by “A”, is only available during the entry phase. Fig. 9(b) and Fig. 10 give the scenario model of APU launch mission by ET and DFTs in two phases for a better comparison. Symbols in the Fig. 10 are explained in [22].

The following assumptions are made for this example.

- (1) The time of failure of all components is exponentially distributed. The failure rates of all given basic events and the mission duration of both phases are represented in [22].
- (2) All components are non-repairable. Once a component fails, it will maintain its status for the remainder of the mission.

Based on the above-mentioned presentation, the combining E/DFTs are presented along with application to the APU system includ-

ing multi-type dependencies (Shared APU_i, external common cause failure modelled by FDEP gate, hot spare, and phase-dependency).

4.2.2. Construction of PMS-DBN

In the first phase, APU system can be treated as a single system, and the DBN model of ascent phase is easily constructed as shown in Fig. 11(a). In the second phase, because phase 1 and phase 2 are consecutive and non-overlapped, the end net (as seen in right hand of Fig.11 (a)) in phase 1 at time T1 is the initial conditions of the phase 2 at time T1, and the initial probabilities in phase 2 at time T1 are equal to the end probabilities in phase 1 for each state. The PMS temporal behaviour in phase 2 is the same as phase 1 other than the APU control spare, denoted by “A”, activated in phase2. Finally we obtain the established model of DBN using GeNIe, as seen in Fig. 11 (b).

4.2.3. Quantitative analysis results

Based on the exact reasoning algorithm of the GeNIe software platform, the complete failure probability during the mission time with all the four failure modes can be calculated as shown in Fig.12.

Fig. 12 presents that the failure mode curves in the conversion time of first phase and second phase are jumping, and the probabilities of mode OK and mode F1 increase in different degrees. Therefore,

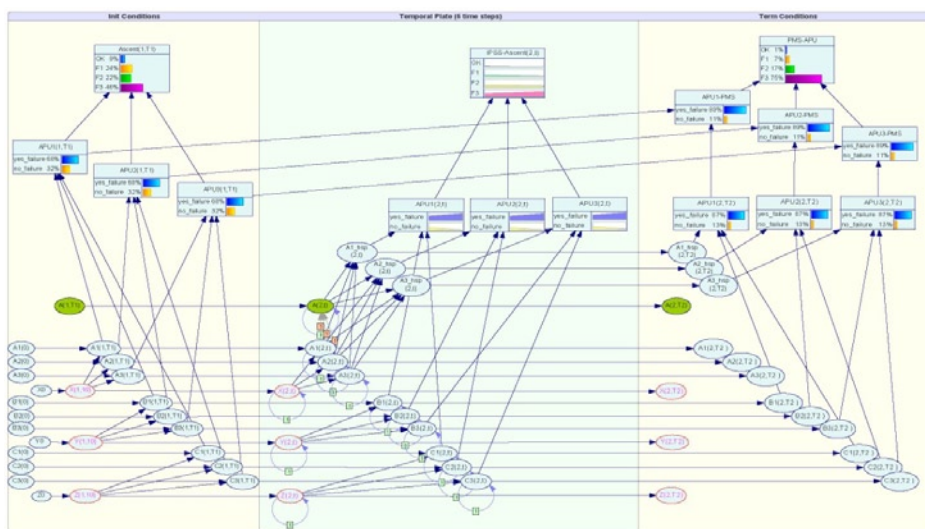

Fig. 14. Modified DBN to account four outcome modes using GeNIe

the redundancy of “A” can reduce the failure probability greatly to improve the system reliability.

To assess the risk of catastrophic failure in the mission, we define the mission success criteria as follow: (1) On Ascent: mode OK and failure mode F_1 are considered as success, and failure mode F_2 and F_3 are considered as failure; (2) On Entry: mode OK is considered as mission success, and once any APU fails, lunch mission will fail.

Fig. 13 is the risk curve of mission loss, because the second mission success criterion is more rigorous than the previous phase, there is a remarkable jump in the conversion time of the first and second phase. Considering different configuration and mission phase success criteria, it is observed that DBN produces a more explicit measure of the system reliability and risk level over time.

4.2.4. Validation of the method

Xu and Dugan[22] introduced MC-based E/DFT for APU reliability analysis, and proposed a modularization method to improve efficiency due to the problem of building a single MC for the whole system. Results of four ET outcome mode probabilities obtained from the Xu and Dugan’s work are shown in column 2 of Table 3.

Compared to the MC model, the modified DBN to account four outcome modes is easily constructed by adding several nodes and corresponding arcs to obtain different combinations of APUi status (as shown in Fig. 14), and all the outcome mode probabilities are given in column 3 of Table 3.

Table 3. Probabilities comparison of outcome modes under DBN and MC

Outcome Mode	MC results	DBN results	error
OK	0.01056	0.01072	1.52%
F_1	0.06858	0.07118	3.80%
F_2	0.16517	0.16876	2.17%
F_3	0.75569	0.74934	0.84%

This result shows that small percentage errors exist between DBN-based method and MC-based method even in this complex system, besides that, DBN can construct a more integrative system scenarios model relative to Markov method.

5. Conclusion

This study has presented a new method to analyze time-dependencies in E/FT model when performing PMS reliability and risk analysis by using Bayesian networks. Various types of dependencies especially time-dependency in event trees are discussed. The proposed method shows how to use conditional probability to give expression of the phase-dependency, and further expands by the dynamic BN to cope with more complex time-dependency. The results obtained from a real auxiliary power unit system have shown this method’s engineering applicability on large and complex engineering systems.

The advantage of the BN-based approach is that it is easy to understand and use in practice owe to the flexible modeling ability and mature inference algorithm of Bayesian networks. And yet for all that, it is just the beginning of our work. One challenge is related to the unnecessarily large networks due to the DBN repeating the same structure for each time instance, but may find its solution within the any time horizon of 2-time-slice BN structures. Future works may be devoted to extensions of the proposed approach, such as modeling the units with the repairable function, and more complex mission success logical relationships, so that the model can be closer to the reality of the system.

References

- Andrews J, Dunnett SJ. Event-tree analysis using binary decision diagrams. *IEEE Transactions on Reliability* 2000; 49(2): 230–238, <http://dx.doi.org/10.1109/24.877343>.
- Bobbio A, Portinale L, Minichino M, Ciancamerla E. Improving the analysis of dependable systems by mapping FTs into Bayesian networks. *Journal of Reliability Engineering and System Safety* 2001; 71: 249–260, [http://dx.doi.org/10.1016/S0951-8320\(00\)00077-6](http://dx.doi.org/10.1016/S0951-8320(00)00077-6).
- Esary JD, Ziehms H. Reliability analysis of phased missions. In: Barlow RE, Fussell JB, Singpurwalla ND, editors. *Reliability and fault tree analysis: theoretical and applied aspects of system reliability and safety assessment*. Philadelphia, PA: SIAM; 1975: 213–236.
- Hadi Hosseini, SM, Takahashi M. Combining Static/Dynamic Fault Trees and Event Trees Using Bayesian Networks. *SAFECOMP*; 2007: 93–99.
- Khakzad N, Khan F, Amyotte P. Safety analysis in process facilities: Comparison of fault tree and Bayesian network approaches. *Reliability Engineering and System Safety* 2011; 96: 925–932, <http://dx.doi.org/10.1016/j.res.2011.03.012>.
- Khakzad N, Khan F, Amyotte P. Dynamic safety analysis of process systems by mapping bow-tie into Bayesian network. *Process Safety and Environmental Protection* 2013; 91:46–53, <http://dx.doi.org/10.1016/j.psep.2012.01.005>.
- Kim K, Park KS. Phased-mission system reliability under Markov environment. *IEEE Transactions on Reliability* 1994, 43(2): 301–309, <http://dx.doi.org/10.1109/24.295013>.
- Lampis M, Andrews D. Bayesian belief networks for system fault diagnostics. *International Journal of Quality and Reliability Engineering* 2009; 25: 409–426, <http://dx.doi.org/10.1002/qre.978>.
- Langseth H, Portinale L. Bayesian networks in reliability. *Reliability Engineering and System Safety* 2007; 92(1):92–108, <http://dx.doi.org/10.1016/j.res.2005.11.037>.
- Marsh DWR, Bearfield G. Generalizing event trees using Bayesian networks. *Proceedings of the Institution of Mechanical Engineers, Part O: Journal of Risk and Reliability* 2008; 222: 105–114, <http://dx.doi.org/10.1243/1748006XJRR131>.
- Montani S, Portinale L, Bobbio A, Codetta-Raiteri D. RADYBAN: a tool for reliability analysis of dynamic FTs through conversion into dynamic Bayesian networks. *Reliability Engineering and System Safety* 2008; 93:922–932, <http://dx.doi.org/10.1016/j.res.2007.03.013>.
- Mura I, Bondavalli A. Markov regenerative stochastic Petri nets to model and evaluate phased mission systems dependability. *IEEE Transactions on Computers* 2001; 50(12): 1337–1351, <http://dx.doi.org/10.1109/TC.2001.970572>.
- Nývlt O, Rausand M. Dependencies in event trees analyzed by Petri nets. *Reliability Engineering and System Safety* 2012; 104: 45–47, <http://dx.doi.org/10.1016/j.res.2012.03.013>.

14. Portinale L, Raiteri DC, Montani S. Supporting reliability engineers in exploiting the power of dynamic Bayesian networks. *International Journal of Approximate Reasoning*2010; 51: 179-195, <http://dx.doi.org/10.1016/j.ijar.2009.05.009>.
15. Dugan JB. Automated Analysis of Phased-Mission Reliability. *IEEE Transaction on Reliability*1991; 10(1): 45-53, <http://dx.doi.org/10.1109/24.75332>.
16. Stamatelatos M. Probabilistic Risk Assessment Procedures Guide for NASA Managers and Practitioners. Technical report. US NASA, Office of Safety and Mission Assurance, NASA Headquarters, Washington, DC; 2011. NASA/SP-2011-3421.
17. Tang ZH, Dugan JB. BDD-Based Reliability Analysis of Phased-Mission Systems With Multimode Failures. *IEEE transactions on Reliability*2006; 55(2): 350-360, <http://dx.doi.org/10.1109/TR.2006.874941>.
18. Tang ZH, Xu H, Dugan JB. Reliability Analysis of Phased Mission Systems with Common Cause Failures. In: *Reliability and Maintainability Symposium, 2005 annual symposium-RAMS*; 2005: 313–318.
19. Wang CN, Xing LD, Levitin G. Competing failure analysis in phased-mission systems with functional dependence in one of phases. *Reliability Engineering and System Safety*2012; 108 : 90-99, <http://dx.doi.org/10.1016/j.res.2012.07.004>.
20. Weber P, Medina-Oliva G, Simon C, Iung B. Overview on Bayesian networks applications for dependability, risk analysis and maintenance areas. *Engineering Applications of Artificial Intelligence*2012; 25: 671-682, <http://dx.doi.org/10.1016/j.engappai.2010.06.002>.
21. Xing LD, Levitin G. BDD-based reliability evaluation of phased-mission systems with internal/external common-cause failures. *Reliability Engineering and System Safety* 2013; 112: 145–153, <http://dx.doi.org/10.1016/j.res.2012.12.003>.
22. Xu H. Dynamic event fault tree(DEFT): a methodology for probabilistic risk assessment of computer-based systems. Ph.D. Dissertation. Charlottesville: University of Virginia, 2008
23. Xu H, Dugan JB. Combining dynamic fault trees and event trees for probabilistic risk assessment. In: *Reliability and Maintainability Symposium, 2004 annual symposium-RAMS*; 2004: 214–219.
24. Zang XY, Sun HR, Trivedi KS. A BDD-Based Algorithm for Reliability Analysis of Phased-Mission Systems. *IEEE Transactions on Reliability*1999; 48(1): 50–60, <http://dx.doi.org/10.1109/24.765927>.
25. Zhang LW, Guo HP. Introduction to Bayesian networks [M]. Beijing: Science Press, 2006.

Xiao-Tao LI**Li-min TAO****Mu JIA**

Laboratory of Science and Technology on Integrated Logistics Support

School of Mechatronics Engineering and Automation

National University of Defense Technology

De Ya Road., 109, Changsha, Hunan 410073, P. R. China

E-mails: lxt8866@163.com, tlm1964@sina.com, jiamufight@126.com,
