

Vibration Energy Harvesting, Impact Analysis, Diesel engine

Jacek CABAN [0000-0002-7546-8703]*, *Grzegorz LITAK* [0000-0002-9647-8345]*,
Bartłomiej AMBROŹKIEWICZ [0000-0002-8288-5230]*,
Leszek GARDYŃSKI [0000-0002-4162-179X]*,
Paweł STĄCZEK [0000-0003-0906-7917]*,
Piotr WOLSZCZAK [0000-0001-8603-4647]*

IMPACT-BASED PIEZOELECTRIC ENERGY HARVESTING SYSTEM EXCITED FROM DIESEL ENGINE SUSPENSION

Abstract

Vibration energy harvesting systems are using real ambient sources of vibration excitation. In our paper, we study the dynamical voltage response of the piezoelectric vibrational energy harvesting system (PVEHs) with a mechanical resonator possessing an amplitude limiter. The PVEHs consist of the cantilever beam with a piezoelectric patch. The proposed system was subjected to the inertial excitation from the engine suspension. Impacts of the beam resonator are useful to increase of system's frequency transition band. The suitable simulations of the resonator and piezoelectric transducer are performed by using measured signal from the engine suspension. Voltage outputs of linear (without amplitude limiter) and nonlinear harvesters were compared indicating better efficiency of the nonlinear design.

1. INTRODUCTION

In the last decade, the research interest in vibrational energy harvesting systems (VEHs) has been growing rapidly for applications with small power consumption, mainly in miniaturized electronics, wireless autonomous sensors used in medical and health monitoring, structural health monitoring, or smart buildings.

* Lublin University of Technology, Faculty of Mechanical Engineering, Nadbystrzycka 36, 20-618 Lublin, Poland, j.caban@pollub.pl, g.litak@pollub.pl, b.ambrozkiewicz@pollub.pl, l.gardynski@pollub.pl, p.staczek@pollub.pl, p.wolszczak@pollub.pl

In particular, self-powered sensors can use the information of any engineering or physical phenomena represented in the signal in the corresponding time series (Smutny, Nohal, Vukusicova & Seelmann, 2018). In the auto-motive sector, numerous methods can be applied to the measured signal in the time domain (Figlus, Szafraniec & Skrucany, 2019). Commercial solutions for energy harvesting from mechanical vibrations are offered in the frame of an intensively developing industrial Internet of Things (IoT). The electrical energy converted from ambient mechanical vibrations can be scavenged from different sources such as forced excitation in seismic and acoustic motions, random or periodic vibrations from sea waves, or vehicle motion. In order to obtain the highest voltage output of the system, the EH design should be adapted to the characteristic frequency of excitation causing operation at the resonant frequency. An alternative approach is to use the frequency broadband effect, namely the system can operate in a wider range of frequencies. At that time, the efficiency is admittedly lower, comparing to the peak resonance output, but the system operates constantly in variable conditions. The obtained output voltage provides a reasonable power supply for the autonomous sensor. On the other hand, the studied Diesel engine and its suspension are typically situated in an environment where energy is available for harvesting.

In the group of VEHs, we can specify electromagnetic (Tan, Dong & Wang, 2017; Ambrozkiewicz, Litak & Wolszczak, 2020), electrostatic (Zhang et al. 2018), and piezoelectric systems (Al-Yafeai, Darabseh & Mourad, 2020; Mieczkowski, Borawski & Szpica, 2019; Koszewnik, 2019, 2020) and their hybrid solutions. In our paper, we focus on the piezoelectric EHs, in which the piezoelectric effect is applied. In piezo-based EH systems obtained voltage output depends on the applied mechanical stress (direct piezoelectric effect). In Figure 1, the general scheme and functional principle of the piezoelectric VEH system are presented (Erturk, Hoffman & Inman, 2009; Litak, Friswell & Adhikari, 2010).

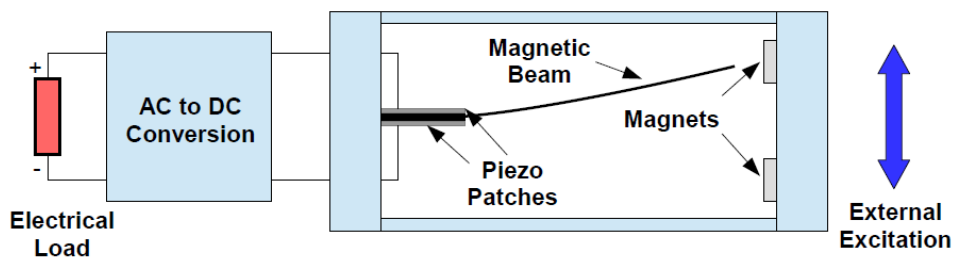

Fig. 1. Scheme of piezoelectric vibrational energy harvesting system based on cantilever beam

On the other hand, the rapid development of the automotive industry and changing into green technology in form of Electric Vehicles (EV) (Łukjanow & Zieliński, 2016; Skrucany, Kendra, Stopka, Milojevic, Figlus & Csiszar, 2019) or Plug-in Hybrids (Šarkan, Gnap & Kiktová, 2019), forces to apply autonomous sensors for condition monitoring systems in the car. The application of the energy harvesting systems seems to be the perfect solution for constant powering up of sensors placed in hardly accessible places such as tires, engine block or suspension column. The range of used sensors in the car is getting wider and wider and three main areas, where they are used can be defined:

- diagnostics,
- active safety,
- navigation & localization.

Tab. 1. The list of sensors in the car possible to power with the EH system

Position sensors	Pressure sensors	Thermal sensors	Inertial measurement unit	Gas and chemical compositions sensors
Fuel level, Engine throttle position, Steering wheel position, Chassis height	Tire pressure monitoring system, Engine manifold pressure sensing system, Cylinder pressure	Exhaust gas temperature, Engine coolant temperature	ABS, IMU-enabled GPS systems	Humidity detection, NO _x detection, CO and CO ₂ emission, Hydrogen detection

Over the decade ago, Matsuzaki & Todoroki (2008) found energy harvesting as the future for powering up autonomous sensors in automotive applications. The paper of Askari et al. (Askari, Hashemi, Khajepour, Khamesee & Wang, 2018) provides wide and rich information on sensors to which the scavenged power from the EH system can be transferred to. In Table 1, the list of chosen sensors in the vehicles is presented.

So far, several solutions of piezoelectric energy harvesting systems based on cantilever beam have been proposed at real-, micro- and nanoscale in automotive applications. Many works are focused on powering up the tire pressure sensor as the tire manufacturers couple them with tire and in most cases they are irreplaceable. The application of piezoelectric energy harvester (PEH) in such solutions

seems to be a perfect solution as on car wheels act a different kinds of excitation coming from bumps, torsions, and accelerations. Bowen et al. (Bowen & Arafa, 2015) presented wide spectra of technologies for a tire pressure monitoring systems, mentioning piezoelectric solutions. Zhu et al. (Zhu, Han & Zhao, 2019) studied the acceleration and power response of the PEH mounted on the wheel by different speeds of the car. Xie et al. (Xie & Wang, 2015) provided a mathematical model for the piezoelectric ring energy harvesting system applied in vehicle tires comparing the power response by different thicknesses of PZT patches, class of road surface, and design of the system.

Another source of continuous vibrations in the car is its suspension. In the paper of Al-Yafeai et al. (Al-Yafeai, Darabseh & Mourad, 2020), the information on PEH implementations and harvested power in the car suspension is provided. Furthermore, Zhang et al. (Zhang, Zheng, Shimono, Kaizuka & Nakano, 2016) proposed the application of the stochastic resonance method for increasing the efficiency of PEH mounted in the suspension of the car.

In the present work, we are focusing on the application of random Diesel engine's vibrations as the source of excitation in the cantilever beam PEH system with an amplitude limiter. The application of impacts in the operating system provides a broadband effect, then the EH system can operate in a wider range of excitation frequencies (Borowiec, Litak & Lenci, 2014). Moreover, the different alignment of stoppers provides adjustable design and variable elastic properties of the system. A similar design was discussed in articles by Khalatkar et al. (Khalatkar & Gupta, 2017), Gatti et al. (Gatti, Ramirez, Febbo & Machado, 2018), and Chandru et al. (Chandru, Murugan & Keerthika, 2016) showing experimental results, Kim et al. (Kim, 2014) instead, proposed torsional vibrations in internal combustion engine as the source of vibration for PEH. The novelty of our research is to check how the impact phenomena will influence the power response of the EH system.

The rest of this paper is organized as follows. Section 2 presents solutions and advantages of impact-based energy harvesting systems. In Section 3, the experimental setup and proposed concept of the piezoelectric EH system with an amplitude limiter are described. Next, in Section 4, the results of numerical simulations in Matlab are shown. Section 5 summarizes the results obtained and the next steps in the development of the system are described.

2. IMPACT-BASED CANTILEVER BEAM PEH

In the case of real applications, the best choice is the nonlinear energy harvesting system as it can operate in a wider range of operational frequencies, than the linear oscillator only adapted to the resonant frequency. One of the approaches to obtain a positive broadband effect into EH is the introduction of impacts, which exploit the effects of non-linearity. In the paper of Vijayan et al., (Vijayan,

Friswell, Khodaparast & Adhikari, 2015) they proposed the model of cantilever beam PEH by which it was proved that contact stiffness and clearance have an influence on the output power. The advantage of the impact introduction into the system is the broadband effect caused by the achievement of bilinear stiffness characteristic resulting in energy harvesting in a wider range of frequencies (Borowiec, Litak & Lenci, 2014). The mentioned design of PEH led to the study of the physical system in the experimental and real environment. In the PhD thesis of Ye Zhang from Louisiana State University, the application of piezo-electric based EH systems in civil infrastructures is discussed (Zhang, 2014). In the papers of Zhao et al. (Zhao & Yang, 2018) and Jung et al. (Jung, Song, Hong, Yang, Hwang, Jeong & Sung, 2015) as the external excitation for PEH, the air stream is used, so such EH systems can have a utilitarian function. Based on related works, in our case, we propose a similar approach to the problem, but the excitation will be the random signal obtained from vibrations generated by the engine.

The PEH used for studying the dynamical response is based on the system proposed by Erturk et al. (Erturk, Hoffmann & Inman, 2009). The system consists of the ferromagnetic beam, two PZT-5A piezo-ceramic patches, and a mechanical amplitude limiter mounted on one side of the closed frame. The position of the mechanical stopper is adjustable, but the results of the response are presented for the only one showing the possibilities of the PEH. The considered system can be divided into the electrical part (piezo patches with the external electrical circuits) and the mechanical part (cantilever beam with amplitude limiter) presented in Figure 2.

The coupling of the two parts can be described by the electromechanical equations of motion with dimensionless parameters as following:

$$\ddot{x} + 2\zeta\dot{x} + x + F_r(x) - \chi v = F(t) \quad (1)$$

$$\dot{v} + \lambda v + \kappa\dot{x} = 0 \quad (2)$$

where: ζ – mechanical damping ratio,
 $F_r(x) = F_0 \Theta(-p - x)(x + p)$ – stopper restore force,
 $F_0 = 100$ – stopper stiffness ratio with respect to the effective normalized beam stiffness,
 Θ – Heaviside step function,
 p – the distance between the stopper stable position of the beam (equilibrium point $x = 0$),
 χ – piezoelectric coupling term in the mechanical circuit equation,
 v – voltage across the load resistance,
 $F = A\omega^2 \cos(\omega t)$ – excitation force,
 A – amplitude of kinematic excitation,
 ω – excitation frequency,

λ – reciprocal of the time constant ($\frac{1}{R_l C_p}$), R_l – load resistance,
 C_p – capacitance of the piezoelectric layers,
 κ – piezoelectric coupling term in the electrical circuit equation,
 t – time.

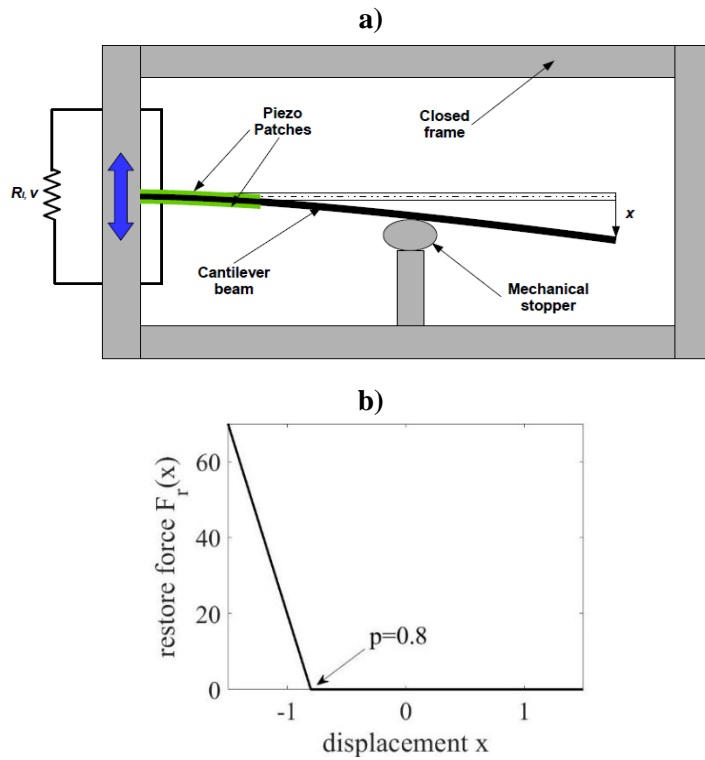

Fig. 2. a) Schematic plot of the piezoelectric energy harvesting system is based on a cantilever beam with mechanical stopper of amplitude – the blue arrows indicate the direction of excitation; b) The restoring force of the stopper with respect to the beam normalized effective stiffness – $p = 0.8$ indicated the distance of the stopper from the equilibrium fixed point ($x = 0$)

The impact was introduced into the system by the Heaviside function, we assumed that its influence will cause a sudden increase of the beam's stiffness by 100 times during contact with the mechanical stopper. Values of other terms used in Eq. 1 and Eq. 2 are collected in Table 2.

Tab. 2. Values of parameters used in electromechanical equations of motion (dimensionless units)

Parameter	Value
ζ	0.01
χ	0.05
λ	0.01
κ	0.50
p	0.80
A	0.183

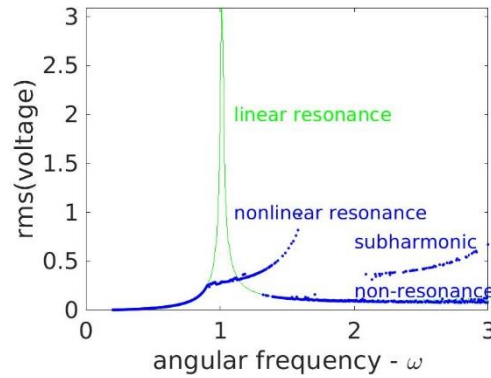

Fig. 3. The comparison of resonance curves for the linear (green line) and nonlinear (blue line) case for EH system. Namely, RMS (Root Mean Square) of voltage output is plotted versus excitation (angular) frequency. In the nonlinear problem, there are additional sub-harmonics (multiple solutions) arouse in result of impact. The calculations are done in such way that for each angular frequency different initial conditions are chosen $[x, \dot{x}, v] = [0, \sigma, 0]$, where σ is a random number uniformly distributed in the interval $[-1,1]$

Based on Eq. 1 and Eq. 2, we performed calculations of the voltage response. The results of calculations are presented in Figure 3. Interestingly, we observe a frequency broad band at the vicinity of the linear frequency resonance $\omega_0 = 1$ and additionally in the interval $\omega \in [2,3]$. Because the impact increases the stiffness of the nonlinear mechanical resonator the resonance curve is strongly inclined into the higher frequencies. Simultaneously, the total amplitude of the excitation is proportional to the square of excitation frequency causing increase of inertial force acting on the beam (Eq. 1). Note also that the width is much wider comparing to the linear resonance. On the other hand in the region of $\omega \in [1.2, 1.5]$ there two coexisting solutions including resonance and non-resonance ones. The non-resonance solution is a solution without impact. The situation is repeating for higher frequencies, $\omega \in [2, 3]$, where the corresponding resonance solutions is driven by the subharmonic resonance (Huang, Zhou & Litak, 2019; Huguet, Lallart & Badel 2019). Both resonance solutions, main and subharmonic, are forming so called broad band effect in the studied harvester with impacts.

3. EXPERIMENTAL SETUP

For the research subject, the Diesel engine (2.5 Turbo Diesel – 4C90 Andoria) was chosen as in the case of this type of engine, we can expect the highest amplitudes of vibrations (Taghizadeh-Alisaraei, Ghobadian, Tavakoli-Hashjin & Mohtasebi, 2012). The measurement system (Figure 4) used for recording vibrations was previously described in the article of Gardyński et al. (Gardyński, Caban & Drożdżiel, 2015) consisting of 1) clamping arm, 2) potentiometer arm and 3) linear potentiometer. The measured displacement was converted into voltage and transferred to the oscilloscope DSO-2902 256K. The potentiometer applied to measurements is an A-linear type with 22 k Ω resistance and 0.5% linear tolerance and was mounted at 540 mm above the crankshaft. The scale of the potentiometer is the following: 1.6 mm displacement corresponds to a 1 V voltage response.

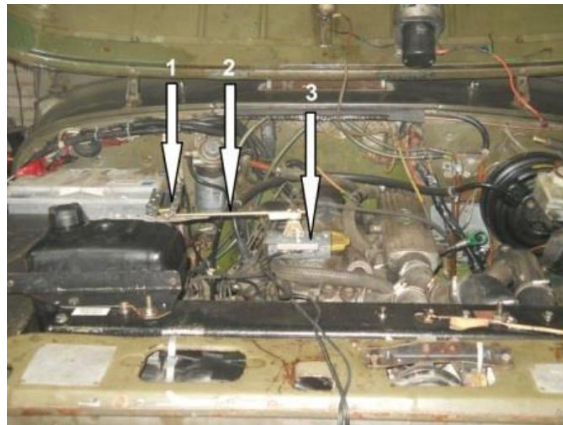

Fig. 4. The measuring system mounted on the engine block

The scheme of the measuring circuit is presented in Figure 5, the best place for mounting the EH system is the engine block, where are the pure vibrations of the operating engine. The potentiometer coupled with the oscilloscope and PC provides proper registration and visualization of the displacement signal. The measurements were performed for the operational velocity: $n = 800$ rpm (Figure 6).

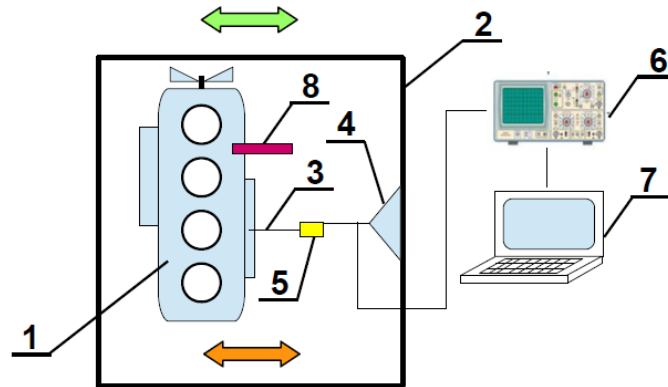

Fig. 5. The measuring circuit for engine displacement and mounted EH system on the engine block. The measuring circuit consists of the following equipment: 1 – Diesel Engine, 2 – Vehicle body, 3 – Potentiometer arm, 4 – Load-bearing structure, 5 – Linear potentiometer, 6 – Oscilloscope, 7 – Computer, 8 – Piezoelectric energy harvester (the orange arrow refers to the horizontal engine’s vibrations and the green refers to vehicle’s vibrations during driving)

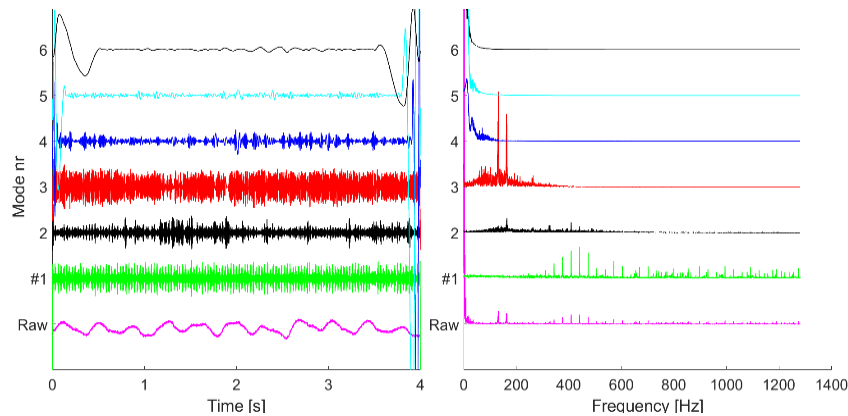

Fig. 6. Analysis of the frequency of engine vibration (displacement time series) signal components – left diagram: empirical mode decomposition, right diagram: Fast Fourier Transformation (FFT) of raw signal and empirical modes (for the analysis, the case 800 rpm was considered)

Usually, experimental signals have a strong nonlinear character, and the application of the Hilbert-Huang transform (HHT) allows separating characteristic modes of the raw signal. Additionally, Fast Fourier Transformation (FFT) helps to define the characteristic frequencies occurring in the spectra. In Figure 6, the results of HHT decomposition and its frequency analysis are presented. The raw signal consists of 6 modes and its number is defined by the period of signal recording (Feng, Liang & Chu, 2013). Based on the performed analysis, in the

experimental signal, there are many higher harmonics. However, some of them are affected by measurement errors, which cannot be used to estimation of the inertial force $F(t)$ as defined in Eq. 1. To overcome this difficulty, we used the FFT spectral low-pass filtering shown in Figure 7.

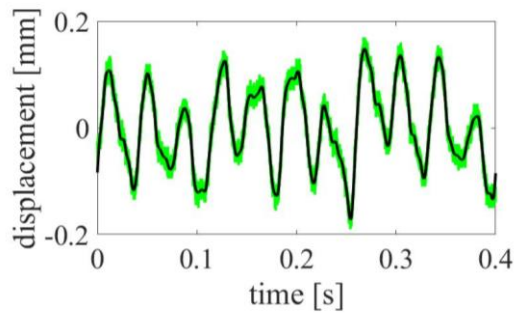

Fig. 7. Spectral low-pass filtering (the measured signal is plotted in green while the filtered one in black color)

4. MODEL FITTING RESULTS AND DISCUSSION

Using the repetition of the measured signal, we continued it for a longer time and adjusted to the non-dimensional model (Eq. 1 and Eq. 2). The course of the inertial force is calculated as the second-order derivative of the displacement signal (Figure 8).

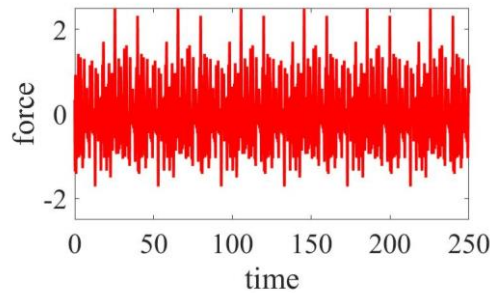

Fig. 8. Time course of inertial force for the case $n = 800$ rpm

In Figure 9, the results of the output voltage are presented. The worth noticing fact is that impacts support stable oscillations of the beam and its transient increase (a). In the linear case (b), there is constant damping of the beam's movement in time. To visualize the influence of the impact on the cantilever beam, the phase portraits are shown (Figure 10). The added dashed

vertical line on the plot represents the distance of set the amplitude limiter. If there is no limiter, the beam oscillates from peak to peak and around the stable point $x = 0$ (a). The contact with amplitude limiter shows a clear beam's reflection (b) and an increase of oscillations' amplitude on the side without the limiter.

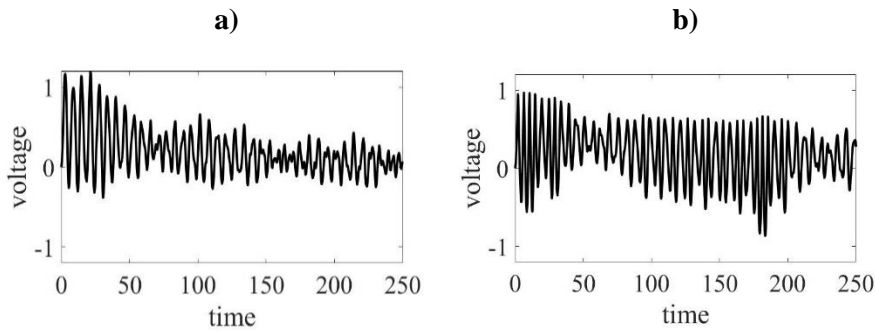

Fig. 9. The comparison results of output voltage for linear (a) and nonlinear (b) case – it is worth observing that by impacts there the damping effect is smaller; the corresponding Root Mean Square of the voltage output: RMS (voltage) is 0.1025 and 0.1330 for linear a) and nonlinear b) energy harvesters respectively

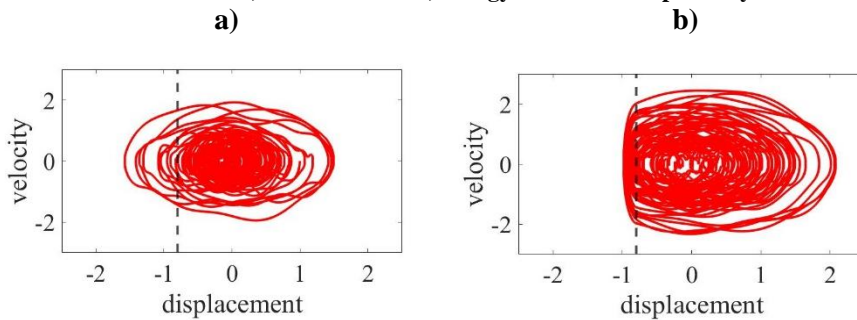

Fig. 10. Phase portraits of the energy harvesting resonator response – the limit of amplitude is set to $x = -0.8$ (black dashed line); picture (a) represents the case without amplitude limiter, (b) with impact

5. CONCLUSIONS

For the analysis, a vibrational piezoelectric energy harvesting system was used in which the experimental multi-frequency excitations coming from diesel engine were adopted. The introduction of the amplitude limiter to the system brought a positive effect on the dynamic response. Comparing linear (without impacts) with nonlinear (with impacts) cases, there is an effect of higher voltage output from the second. Impacts of the beam over the amplitude limiter cause

oscillations of the higher level, concerning the linear solution there is a dissipation of oscillations were present (see Figures 9 a and b). Additionally, the application of experimental multi-frequency vibrations improved the broadband effect of the system, as the occurrence of subharmonic branches can be induced easier in the resonance curve (Figure 3, blue line). The next steps in the planned investigations will be testing the performance of the physical system in the real environment and compare the output power with approaches including energy harvesting designed to moving rotating or swinging parts.

Acknowledgement

This work was supported by the program of the Ministry of Science and Higher Education in Poland under the project  DIALOG 0019/DLG/2019/10 in the years 2019–2021.

REFERENCES

- Al-Yafeai, D., Darabseh, T., & Mourad, A.H.I. (2020). A state-of-the-art review of car suspension-based piezoelectric energy harvesting systems. *Energies*, *13*, 2336. <https://doi.org/10.3390/en13092336>
- Ambrozkiewicz, B., Litak, G., & Wolszczak, P. (2020). Modelling of electromagnetic energy harvester with rotational pendulum using mechanical vibrations to scavenge electrical energy. *Applied Sciences*, *10*, 671. <https://doi.org/10.3390/app10020671>
- Askari, H., Hashemi, E., Khajepour, A., Khamesee, M.B., & Wang, Z.L. (2018). Towards self-powered sensing using nanogenerators for automotive systems. *Nano Energy*, *53*, 1003–1019. <https://doi.org/10.1016/j.nanoen.2018.09.032>
- Borowiec, M., Litak, G., & Lenci, S. (2014). Noise effected energy harvesting in a beam with stopper. *International Journal of Structural Stability and Dynamics*, *14*, 1440020. <https://doi.org/10.1142/S0219455414400203>
- Bowen, C.R., & Arafa, M.H. (2015). Energy harvesting technologies for tire pressure monitoring systems. *Advanced Energy Materials*, *5*, 1401787. <https://doi.org/10.1002/aenm.201401787>
- Chandru, A.A., Murugan, S.S., & Keerthika, V. (2016). Design and implementation of an energy harvester for Low-Power devices from vibration of automobile engine. *Advances in Intelligent Systems and Computing*, *397*, 1–8.
- Erturk, A., Hoffmann, J., & Inman, D.J. (2009). A piezomagnetoelastic structure for broadband vibration energy harvesting. *Applied Physics Letters*, *94*, 254102. <https://doi.org/10.1063/1.3159815>
- Feng, Z., Liang, M., & Chu, F. (2013). Recent advances in time-frequency analysis methods for machinery fault diagnosis: A review with application examples. *Mechanical Systems and Signal Processing*, *38*, 165–205. <https://doi.org/10.1016/j.ymssp.2013.01.017>
- Figlus, T., Szafraniec, P., & Skrucany, T. (2019). Methods of measuring and processing signals during tests of the exposure of a motorcycle driver to vibration and noise. *International Journal of Environmental Research and Public Health*, *16*, 17, 3145. <https://doi.org/10.3390/ijerph16173145>
- Gardyński, L., Caban, J., & Drożdziel, P. (2015). The impact of stiffness of engine suspension cushions in an all-terrain vehicle on its transverse displacement. *Journal of Science of the Military Academy of Land Forces*, *47*, 95–102.

- Gatti, C.D., Ramirez, J.M., Febbo, M., & Machado, S.P. (2018). Multimodal piezoelectric device for energy harvesting from engine vibration. *Journal of Mechanics of Materials and Structures*, 13, 17-34. <https://doi.org/10.2140/jomms.2018.13.17>
- Huang, D., Zhou, S., & Litak, G. (2019). Theoretical analysis of multi-stable energy harvesters with high order stiffness terms. *Communications in Nonlinear Science and Numerical Simulation*, 69, 270-286. <https://doi.org/10.1016/j.cnsns.2018.09.025>
- Huguet, T., Lallart, M., & Badel, A. (2019). Orbit jump in bistable energy harvesters through buckling level modification. *Mechanical Systems and Signal Processing*, 128, 202–215. <https://doi.org/10.1016/j.ymsp.2019.03.051>
- Jung, H.J., Song, Y., Hong, S.K., Yang, C.H., Hwang, S.J., Jeong, S.Y., & Sung, T.H. (2015). Design and optimization of piezoelectric impact-based micro wind energy harvester for wireless sensor network. *Sensors and Actuators, A* 222, 314–321. <https://doi.org/10.1016/j.sna.2014.12.010>
- Khalatkar, A.M., & Gupta, V.K. (2017). Piezoelectric energy harvester for low engine vibrations. *Journal of Renewable and Sustainable Energy*, 9, 024701. <https://doi.org/10.1063/1.4979501>
- Kim, G.W. (2014). Piezoelectric energy harvesting from torsional vibration in internal combustion engines. *International Journal of Automotive Technology*, 16, 645–651. <https://doi.org/10.1007/s12239-015-0066-6>
- Koszewnik, A. (2019). Analytical modelling and experimental validation of an energy harvesting system for the smart plate with integrated piezo-harvester. *Sensors*, 19, 812. <https://doi.org/10.3390/s19040812>
- Koszewnik, A. (2020). Experimental validation of equivalent circuit modelling of the piezo-stripe harvester attached to SFSF rectangular plate. *Acta Mechanica et Automatica*, 14, 8–15. <https://doi.org/10.2478/ama-2020-0002>
- Litak, G., Friswell, M.I., & Adhikari, S. (2010). Magnetopiezoelectric energy harvesting driven by random excitations. *Applied Physics Letters*, 96, 214103. <https://doi.org/10.1063/1.3436553>
- Łukjanow, S., & Zieliński, W. (2016). Examination and assessment of electric vehicles' operational safety. *The Archives of Automotive Engineering – Archiwum Motoryzacji*, 74, 4, 59–82. <https://doi.org/10.14669/AM.VOL74.ART5>
- Matsuzaki, R., & Todoroki, A. (2008). Wireless Monitoring of Automobile Tires for Intelligent Tires. *Sensors*, 8, 8123-8138. <https://doi.org/10.3390/s8128123>
- Mieczkowski, G., Borawski, A., & Szpica, D. (2019). Static electromechanical characteristic of three-layer circular piezoelectric transducer. *Sensors*, 20, 222. <https://doi.org/10.3390/s20010222>
- Šarkan, B., Gnap, J., & Kiktová, M. (2019). The importance of hybrid vehicles in urban traffic in terms of environmental impact. *The Archives of Automotive Engineering – Archiwum Motoryzacji*, 85, 3, 115–122. <https://doi.org/10.14669/AM.VOL85.ART8>
- Skrucany, T., Kendra, M., Stopka, O., Milojevic, S., Figlus, T., & Csiszar, C. (2019). Impact of the electric mobility implementation on the Greenhouse Gases production in central European Countries. *Sustainability*, 11(18), 4948. <https://doi.org/10.3390/su11184948>
- Smutny, J., Nohal, V., Vukusicova, D., & Seelmann, H. (2018). Vibration analysis by the Wigner-Ville transformation method. *Communications – Scientific Letters of the University of Zilina*, 20, 4, 24–28.
- Taghizadeh-Alisarai, A., Ghobadian, B., Tavakoli-Hashjin, T., & Mohtasebi, S.S. (2012). Vibration analysis of a diesel engine using biodiesel and petrodiesel fuel blends. *Fuel*, 102, 414–422.
- Tan, Y., Dong, Y., & Wang, X. (2017). Review of MEMS electromagnetic vibration energy harvester. *Journal of Microelectromechanical Systems*, 26, 1–16.
- Vijayan, K., Friswell, M.I., Khodaparast, H.H., & Adhikari, S. (2015). Non-linear energy harvesting from coupled impacting beams. *International Journal of Mechanical Sciences*, 96-97, 101-109. <https://doi.org/10.1016/j.ijmecsci.2015.03.001>
- Xie, X., & Wang, Q. (2015). A mathematical model for piezoelectric ring energy harvesting technology from vehicle tires. *International Journal of Engineering Science*, 94, 113–127. <https://doi.org/10.1016/j.ijengsci.2015.05.004>

- Zhang, Y. (2014). Piezoelectric based energy harvesting on low frequency vibrations of civil infrastructures. *LSU Doctoral Dissertations*, 1342.
- Zhang, Y., Wang, T., Luo, A., Yushen, H., Li, X., & Wang, F. (2018). Micro electrostatic energy harvester with both broad bandwidth and high normalized power density. *Applied Energy*, 212, 362–371. <https://doi.org/10.1016/j.apenergy.2017.12.053>
- Zhang, Y., Zheng, R., Shimono, K., Kaizuka, T., & Nakano, K. (2016). Effectiveness testing of a piezoelectric energy harvester for an automobile wheel using stochastic resonance. *Sensors*, 16(10), 1727. <https://doi.org/10.3390/s16101727>
- Zhao, L., & Yang, Y. (2018). An impact-based broadband aeroelastic energy harvester for concurrent wind and base vibration energy harvesting. *Applied Energy*, 212, 233–243. <https://doi.org/10.1016/j.apenergy.2017.12.042>
- Zhu, B., Han, J., & Zhao, J. (2019). Study of Wheel Vibration Energy Harvesting for Intelligent Tires. *Lecture Notes in Electrical Engineering*, 486, 971–978. https://doi.org/10.1007/978-981-10-8506-2_65