

IMPROVING OPTICAL FIBER SENSING BY MIMO SIGNAL PROCESSING

Andreas Ahrens¹, André Sandmann¹, Kort Bremer², Bernhard Roth², Steffen Lochmann¹

¹Hochschule Wismar, Philipp-Müller Straße 14, 23966 Wismar, Germany, ²Leibniz University Hannover, Nienburger Strasse 17, 30167 Hannover, Germany

Abstract. Optical fiber sensors have reached a high state of maturity. Besides the high number of sensor groups, multi-mode fiber evanescent field sensors can be found in a lot of applications. Here, the signal source commonly excites many optical modes under steady-state conditions. Perturbations of the fiber then produce leaky modes. Thus, a simple intensity detector measures the degree of perturbation. In some cases also restricted mode launching conditions have been applied. They resulted in higher sensitivity but showed a narrower measurement range. Considering the individual modes as carriers of information we adapted multiple-input multiple-output (MIMO) signal processing which is well studied in the telecommunications community, for improvements on both the sensor sensitivity and its measurement range. In this paper MIMO signal processing is investigated for fiber optic sensor applications. A (2x2) MIMO implementation is realized by using lower-order and higher-order mode groups of a gradient-index multi-mode fiber as separate transmission channels. A micro-bending pressure sensor changes these separate transmission characteristics and introduces additional crosstalk. By observing the layer specific weight-factors of the MIMO system the amount of load applied was determined. Experiments verified a good correlation between the change of the MIMO weight coefficients and the load applied to the sensor and thus verified that MIMO signal processing can beneficially be used for fiber optic sensor applications. The experimental results also verified the superior sensitivity and measurement range when MIMO signal processing is utilized.

Keywords: MIMO, optical fiber sensors

POPRAWA WŁAŚCIWOŚCI CZUJNIKÓW ŚWIATŁOWODOWYCH Z UŻYCIEM PRZETWARZANIA MIMO

Streszczenie. Czujniki światłowodowe osiągnęły wysoki stan dojrzałości technologicznej. Wśród dużej liczby typów czujników, wiele zastosowań znajdują wielomodowe czujniki zanikającego pola. Najczęściej w tych czujnikach źródło promieniowania w stanie ustalonym wzbudza wiele modów. Zaburzenia we włóknie powodują powstanie modów wyciekających. Tak więc, prosty czujnik natężenia mierzy stopień zaburzenia. W pewnych przypadkach zastosowano ograniczenia wzbudzenia modów. Spowodowało to wzrost czułości lecz jednocześnie ograniczyło zakres pomiarowy. W celu poprawienia zarówno czułości, jak i zakresu pomiarowego, zastosowana została dobrze znana w telekomunikacji technika przetwarzania sygnałów MIMO (wiele wejść wiele wyjść) traktująca poszczególne mody jako nośniki informacji. W artykule opisano badania nad zastosowaniem techniki przetwarzania sygnałów MIMO do czujników światłowodowych. Implementacja MIMO (2x2) została zrealizowana poprzez podział modów w gradientowym światłowodzie wielomodowym na grupę wyższego i niższego rzędu i użyciu ich jako dwa osobne kanały transmisyjne. W czujniku mikrozgięciowym nacisk zmienia charakterystyki transmisyjne tych kanałów wprowadzając dodatkowy przesłuch. Poprzez obserwację konkretnych współczynników równań MIMO można wyznaczyć wartość nacisku. Doświadczenia potwierdziły dobrą korelację między zmianami współczynników wagowych MIMO i obciążenia czujnika, a więc potwierdziły, że przetwarzanie sygnału MIMO może być z korzyścią wykorzystywane w czujnikach światłowodowych. Wyniki doświadczalne potwierdziły również doskonałą czułość i zakres pomiarowy przy wykorzystaniu przetwarzania sygnału MIMO.

Słowa kluczowe: MIMO, czujniki światłowodowe

Introduction

Fiber optic sensors have the inherent advantage of being immune to Electromagnetic Interference, small in size, robust, resistance to corrosion, electrically passive and easy to multiplex. To date different concepts of fiber optic sensors have been reported based on e.g. Fiber Bragg Gratings, intensity modulated and interferometric sensors as well as on Brillouin, Raman and Rayleigh scattering. Due to the advantages of fiber optic sensors, they have been already applied successfully to measure the structural health of structures such as bridges, dams, mines or advanced composite materials in aircrafts. Furthermore, they have been used to monitor the load of power transmission lines and temperature as well as pressure in oil and gas wells [4]. Though fiber optic sensors have reached a high state of maturity and their fields of application are wide spread more efficient signal processing procedures are still important. Particularly sensors like the whole group of multi-mode fiber (MMF) evanescent field sensors [3, 10] and MMF surface plasmon sensors [9] have the potential of exploiting the multiple optical fiber modes for sensing. The parallel transmitted optical modes can be associated with spatial division multiplexing (SDM) schemes in the field of telecommunications [1]. Such SDM schemes are currently investigated in order to overcome the capacity limit of common single-mode fibers (SMF) [6]. One approach of SDM utilizes individual transversal modes of MMFs for data transmission. However, due to external perturbations such as bending and elongation of the optical fiber along the optical MMF link and fiber imperfections cross-talk occur between the transversal modes and thus multiple-input-multiple-output (MIMO) signal processing has to be applied at the output in order to recover each orthogonal signal at the input. Placing a perturbation device like a micro-bending sensor in this path not only higher transmission

losses but also strong mode coupling occur depending on the measurand.

Commonly, the transmitted power is distributed over all guided optical modes in steady-state condition, where power changes induced by perturbations in the fiber only affects the power in the higher order mode groups, resulting in a low sensitivity. To counter this effect, only specific mode groups, e.g. high order mode groups, can be excited. However, the mode-selective excitation results in a narrow measurement range. A MIMO approach, combining different mode-selective excitations, is expected to amalgamate a high sensitivity with a wide measurement range.

In this paper MIMO signal processing is experimentally explored for fiber optical sensor applications. The experiments are based on a (2x2) MIMO implementation which has been realized by using lower-order and higher-order mode groups of a gradient-index GI-MMF as separate transmission channels. Mode coupling and therefore crosstalk was obtained between the transmission channels by introducing a defined and repeatable perturbation, i.e. by applying a micro-bender and different forces at a certain position along the optical fiber MIMO link. By observing the weight-function of the MIMO system, the amount of perturbation i.e. the amount of force applied was determined.

1. Optical MIMO

The principle of optical MIMO is based on the activation of different transversal modes or mode groups of MMF's as individual data transmission channels and thus to realize parallel data transmission over a single MMF link. An implementation of a (2x2) optical MIMO is based on the utilization of low-order and high-order mode groups as individual transmission channels. These different mode-groups travel together in a MMF and can be separated at the receiver by using spatial mode filters. A schematic

of the spatial mode filters is illustrated in Fig. 1. The corresponding electrical (2x2) MIMO system model is shown in Fig. 2.

The spatial mode filters have been fabricated by initially coating the end-face of a graded-index MMF with gold and then partly removing the coating again by using Focused Ion Beam milling. The resulting spatial mode filter only allows light of a certain spatial distribution to reach the detector. All other light is reflected back into the fiber. Moreover, the excitation of the different mode-groups can be done through various methods. Besides using Spatial Light Modulators, Long-Period Gratings or Photonic Crystals, the excitation can simply be carried out by a centric or an eccentric splice between a SMF and a MMF. The measurement setup depicted in Fig. 3 shows the testbed with the utilized devices for measuring the system properties of the optical

MIMO channel in form of its specific impulse responses needed for modeling the MIMO data transmission.

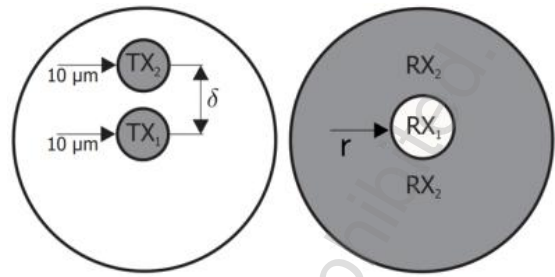

Fig. 1. Forming the optical MIMO channel (left: light launch positions at the transmitter side with a given eccentricity δ , right: spatial configuration at the receiver side as a function of the mask radius r)

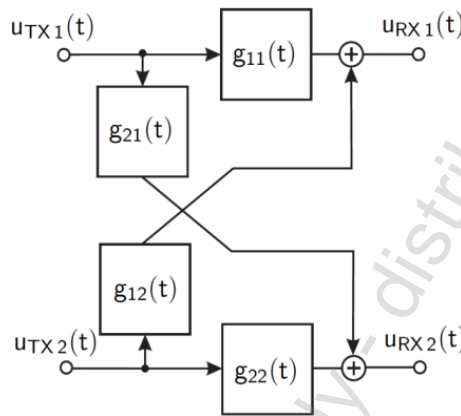

Fig. 2. Electrical (2x2) MIMO system model

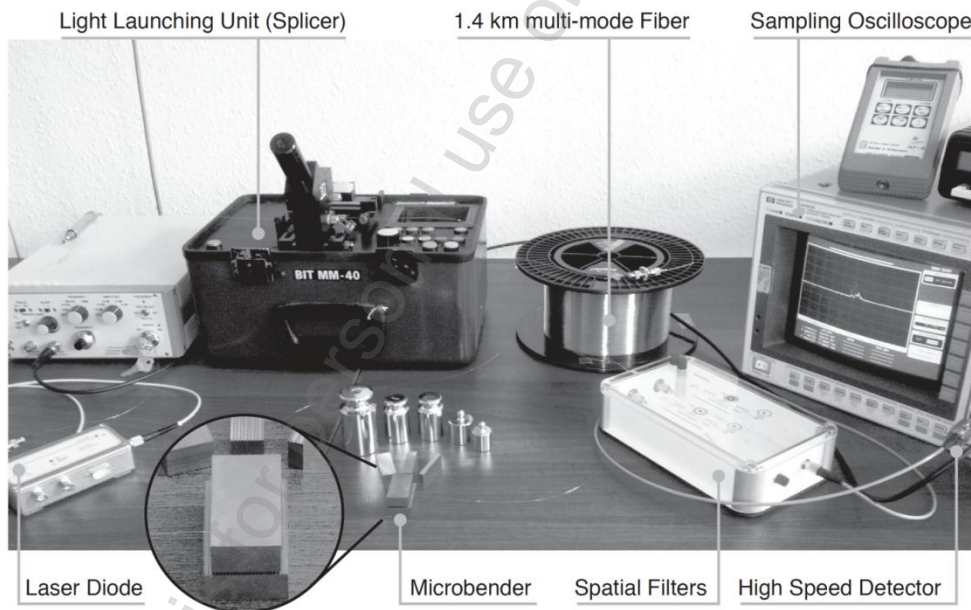

Fig. 3. Measurement setup for determining the MIMO specific impulse responses

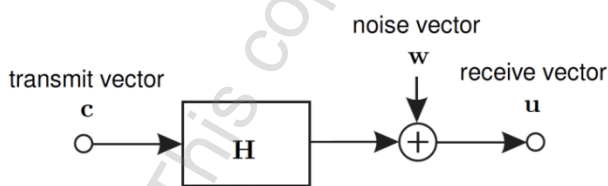

Fig. 4. Transmission system model

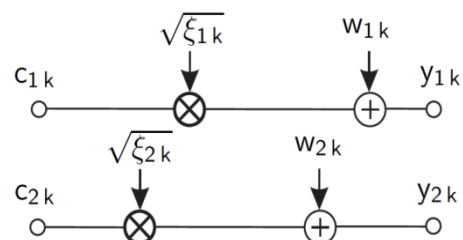

Fig. 5. SVD-based layer-specific transmission model

This copy is for personal use only - distribution prohibited.

2. System model

The block diagram of the transmission model is shown in Fig. 4. The block-oriented system for frequency-selective channels is modeled by:

$$\mathbf{u} = \mathbf{H} \cdot \mathbf{c} + \mathbf{w}, \quad (1)$$

where the transmitted signal vector \mathbf{c} is mapped by the channel matrix \mathbf{H} , containing all the appropriate filtered impulse responses $g(t)$, onto the received vector \mathbf{u} . Finally, the vector of the additive, white Gaussian noise (AWGN) is defined by \mathbf{w} . Details on the transmission model, which has been determined by channel measurements, are given in [5].

In MIMO communication, singular-value decomposition (SVD) has been established as an efficient concept to compensate the interferences between the different data streams transmitted over a time-dispersive channel: SVD is able to transfer the whole system into independent, non-interfering layers exhibiting unequal gains per layer as highlighted in Fig. 5. The first approach analyzes the changes in the first non-zero singular value of the channel matrix \mathbf{H} , i.e. $\sqrt{\xi_{11}}$, in dependency on the measurand. Principally, all singular values can be utilized. The described MIMO model can be used for modulated signals, e.g. a pulse, as well as for continuous wave (CW) signals.

By applying the MIMO concept to optical fiber sensors based on intensity measurements several advantages can be achieved. In standard measurement conditions with full mode excitation mainly the higher order modes disappear due-to perturbations leading to relatively small, i.e. less sensitive power changes in comparison to the main power carried by the other modes. Thus, exciting only individual modes or mode groups results in a much higher sensor sensitivity, e.g. three to six times as shown in [2]. However, the measuring range of the sensor is also reduced since no optical power is left after the disappearance of the information carrying individual mode. Now, MIMO processing has the potential capacity of making use of all the individually launched modes which are transformed from lower to higher order modes in correlation with the disturbance. Thus both a higher sensitivity and a wider measuring range are achieved.

3. Experimental Set-Up

The experimental set-up shown in Fig. 3 was established in order to investigate whether MIMO signal processing in combination with mode-group multiplexing of a GI-MMF can be

applied for optical fiber sensor applications. As illustrated in Fig. 6 the experimental set-up consists of a laser-diode (LD) operating at a wavelength of 1326 nm, 1 m of single-mode fiber (SMF) followed by a micro-bender (MB) using a 2 m GI-MMF, a coil of GI-MMF with a length of 1400 m, a 40 GHz detector (Det), a 50 GHz digital sampling oscilloscope (DSO), a pulse generator (PS) (Picosecond Diode Laser System), a position controller (PC) as well as a spatial mode (MF) filter in front of the detector.

The PC was realized by using the positioning unit of a fusion splicer (BIT MM-40) and was applied in order to excite different mode-groups by changing the off-set position (usually to 10 μm) of the SMF relative to the center of the GI-MMF. The MF only allows light of a certain spatial distribution, i.e. light only from the lower-order or higher-order mode-groups, to reach the detector. The positions of the SMF relative to the center of the MMF core to excite the lower respective higher-order mode groups and the layouts of the two different MF are shown in Fig. 1. The MB has been realized by two opposite metal plates with corrugated surfaces. Both metal plates are separated by the GI-MMF and the periodic perturbations of the two metal plates are facing each other. Therefore, depending on the applied force, micro-bends are introduced into the GI-MMF and thus light is coupled between the mode-groups of the GI-MMF. For the experiments two MB units with five and ten teeth have been utilized, respectively. The pitch of the periodic perturbations is 1 mm which ensures optimum mode coupling [8]. The force applied to the MB was adjusted by using high-precision weights. Using this high bandwidth measurement setup, changes in the modal structure in dependency of the measurand can be determined. A simplified set-up for a practical scenario has also been tested by just measuring the receive power with an optical power meter and transmitting CW light, replacing the pulse generator and the digital sampling oscilloscope.

The measurement setup has been deliberately chosen such that the modal excitation and the filtering of the different modes are conducted sequentially in order to eliminate the influence of mode multiplexing and demultiplexing. For practical set-ups with parallel transmission of different modes, a variety of components for mode coupling and splitting are available, e.g. fusion coupler (see Fig. 7) [7]. Figure 8 exemplarily shows how the LP_{01} mode and a high order principal mode group is multiplexed with a specific fusion coupler into a GI-MMF.

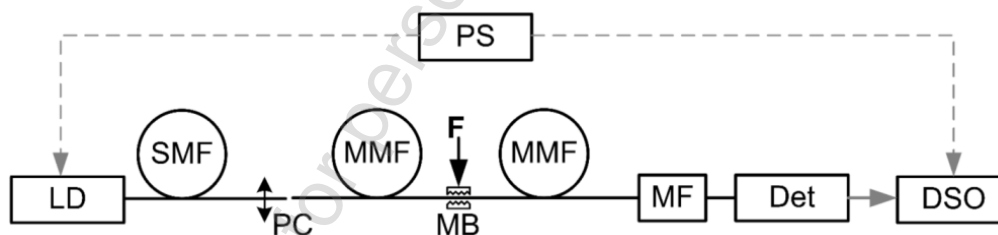

Fig. 6. Experimental set-up in order to demonstrate that MIMO can be applied for optical fiber sensor applications as well

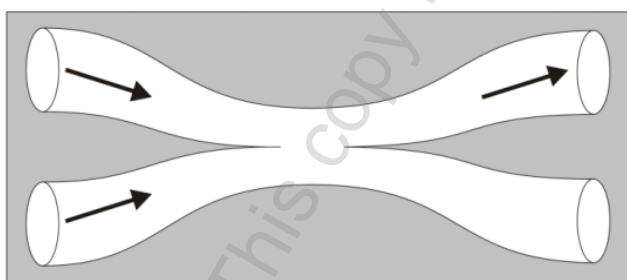

Fig. 7. Mode combining principle in a fusion coupler

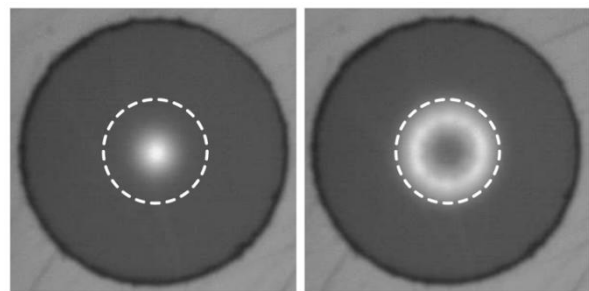

Fig. 8. Measured mean power distribution pattern when using a fusion coupler (left: centric mode excitation; right: eccentric mode excitation); the dotted line represents the 50 μm core size

4. Results

The numerical analysis targets at the correlation of the layer-specific weighting factors with the measurand. Each MB unit has been loaded with different weights and the impulse responses have been measured subsequently [5]. In Fig. 9 and 10 the measured impulse responses are illustrated for a MB unit with ten teeth and 0 gram and 400 gram load, respectively. As illustrated in both figures the peak heights which represent the power carried by individual principal modes are changing due to the applied load. Therefore, the crosstalk and the losses in higher order mode groups are increased, which changes the channel matrix coefficients and hence results in changes of the singular values. Table 1 illustrates the dependence of the MIMO layer-specific weighting factor $\sqrt{\xi_{11}}$ to the different loads for the two MB units. Thus a high correlation between an optical fiber sensor measurand and MIMO processed data has been confirmed to our knowledge for the first time. The results in Table 1 also reveal a high sensitivity of the five teeth MB unit. The stronger response of this unit can be explained by the

higher pressure applied to the GI-MMF. As the surface area of the five teeth MB unit is smaller a higher local pressure is obtained for similar loads.

The described MIMO approach has been compared in terms of sensitivity to conventional approaches for pressure sensing. The first approach uses a launch fiber and a mode mixer to generate a steady-state modal distribution. At this point the micro bender as the sensor element is applied onto the GI fiber and the receive power in dependency of the measurand is quantified. A steady-state excitation guarantees a wide measuring range, but the sensitivity is low as shown by the results depicted in Fig. 11. A mode-selective excitation, realized by launching light from a SMF into a MMF with a certain eccentricity δ as shown in Fig. 1, significantly increases the sensitivity in trade-off for a narrow measuring range. In these results, an eccentricity of 15 μm is used. The MIMO approach, launching with 5 and 15 μm eccentricity, combines the advantage of the steady-state and mode-selective excitation approach, resulting in a high sensitivity over a wide measuring range as shown by the results.

Table 1. Sensor dependent changes in the layer-specific weighting factors (launching with eccentricities of $\delta = 5$ and 15 μm)

Sensor/weight in g	0	100	200	300	400	500	600	700	800	900
5 teeth	0,56	0,51	0,41	0,23	0,09	-	-	-	-	-
10 teeth	0,50	0,49	0,48	0,45	0,42	0,39	0,36	0,33	0,29	0,24

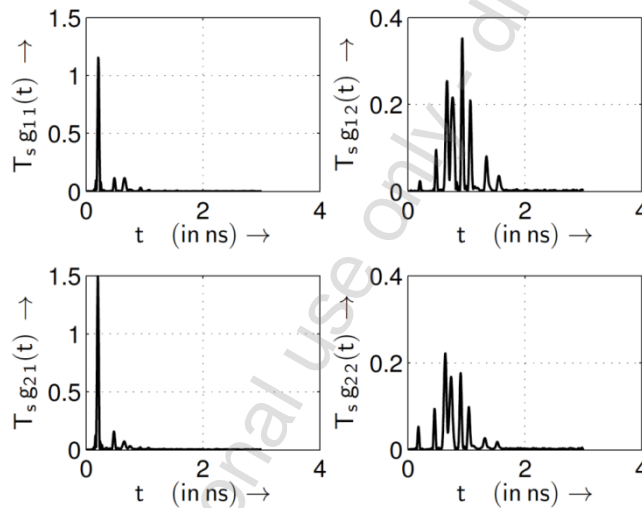

Fig. 9. Measured electrical MIMO impulse responses with respect to the pulse frequency $f_T = \frac{1}{T_s} = 5.12$ GHz at 1326 nm operating wavelength with 0 gram load

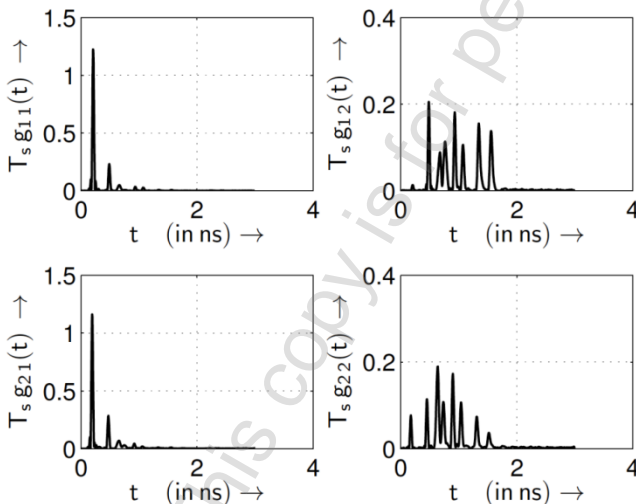

Fig. 10. Measured electrical MIMO impulse responses with respect to the pulse frequency $f_T = \frac{1}{T_s} = 5.12$ GHz at 1326 nm operating wavelength with 400 gram load

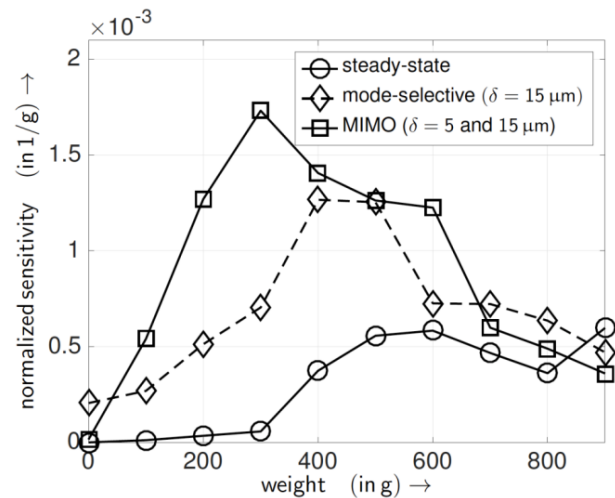

Fig. 11. Sensor sensitivity with respect to different launching and processing conditions using the 10 teeth micro-bender

5. Conclusions

In this paper MIMO signal processing has been successfully investigated experimentally for fiber optic sensor applications. A (2x2) optical MIMO configuration has been realized by using lower-order and higher-order mode groups of a GI-MMF. Mode coupling producing crosstalk between the MIMO specific layers has been introduced by applying a MB sensor unit. The crosstalk was controlled by changing the number of teeth of the MB and applying different weights. The sensitivity to the measurand can be adjusted by the number of teeth of the respective MB sensor unit. A high correlation between an optical fiber sensor measurand and MIMO processed data has been confirmed with this work. In addition, it has been shown that the MIMO approach combines a high sensitivity with a wide measurement range compared to a pure steady-state or mode selective excitation.

Although the focus in this paper is on a (2x2) MIMO processing scheme, a further increase of the sensor measurement range and sensitivity can be expected by upscaling the size of the MIMO system.

References

- [1] Arik S., Kahn J.M., Ho K.P.: MIMO Signal Processing for Mode-Division Multiplexing. *IEEE Signal Processing Magazine* 25(2014).
- [2] Donlagic D.: Microbend sensor structure for use in distributed and quasidistributed Sensor Systems based on selective launching and filtering of the Modes in Graded Index Multimode Fiber. *Journal of Lightwave Technology* 17(10)/1999, 1856–1868.
- [3] Leung A., Shankar P., Mutharasan R.: A review of fiber-optic biosensors. *Sensors and Actuators B* 125/2007, 688–703.
- [4] Leung C.K.Y.: Optical Fiber Sensors for Civil Engineering Applications. *Materials and Structures* 48(4)/2015, 871–906.
- [5] Pankow J., Aust S., Lochmann S., Ahrens A.: Modulation-Mode Assignment in SVD-assisted Optical S. MIMO Multimode Fiber Links. 15th International Conference on Optical Network Design and Modeling (ONDM), Bologna 8–10 February 2011.
- [6] Richardson D.J., Fini J.M., Nelson L.E.: Space Division Multiplexing in Optical Fibres. *Nature Photonics* 7/2013, 354–362.
- [7] Sandmann A., Ahrens A., Lochmann S.: Experimental Description of Multimode MIMO Channels utilizing Optical Couplers. ITG- Fachbericht 248: Photonische Netze. Leipzig, VDE VERLAG GMBH, 05–06 May 2014, 125–130.
- [8] Su L., Chiang K.S., Lu C.: Microbend-induced mode coupling in a graded-index multimode fiber. *Applied Optics* 44(34)/2005, 7394–7402.
- [9] Zamarreno C.R., Hernaez M., Matias I., Arregui F.: Optical fiber sensors based on indium tin oxide surface plasmon resonance supporting coatings. *Proc. OFS-20. Edinburgh, SPIE* 75503, 2009.
- [10] Zhuang X., Li P., Yao J.: A Novel Approach to Evaluate the Sensitivities of the Optical Evanescent Field Sensors. *Fiber Optic Sensors*, Dr Moh. Yasin (Ed.) InTech, 2012.

Prof. Andreas Ahrens

e-mail: andreas.ahrens@hs-wismar.de

Andreas Ahrens received the Dipl.-Ing. degree in electrical engineering from the University of Rostock in 1996. From 1996 to 2008, he was with the Institute of Communications Engineering of the University of Rostock, from which he received the Dr.-Ing. and Dr.-Ing. habilitas degree in 2000 and 2003, respectively. In 2008, he became a Professor for Signal and System theory at the Hochschule Wismar, University of Technology, Business and Design, Germany. His main field of interest includes error correcting codes, multiple-input multiple-output systems and iterative detection for both wireline and wireless communication.



B.Eng. André Sandmann

e-mail: a.sandmann@stud.hs-wismar.de

André Sandmann received the B.Eng. degree in information and electrical engineering from the Hochschule Wismar, University of Technology, Business and Design, Germany, in 2014. Currently he is pursuing the M.Eng. degree. Since 2013 he is working as a student researcher within the Communications Signal Processing Group. His research interests are MIMO communications systems, fiber-optic communication and signal processing.



Ph.D. Kort Bremer

e-mail: kort.bremer@hot.uni-hannover.de

Kort Bremer graduated at the Hochschule Wismar, Germany in electrical engineering and received a Ph.D. from the University of Limerick, Ireland. Currently he is working at the Hannover Centre for Optical Technologies (HOT) and his research interests include optical fibre sensors and photonic devices.



Prof. Dr. habil. Bernhard Roth

e-mail: bernhard.roth@hot.uni-hannover.de

Bernhard Roth graduated from the University of Bielefeld and obtained his Ph.D. in atomic and particle physics in 2001. From 2002–2007 he was research group leader at the University of Duesseldorf and obtained his state doctorate (Habilitation) in experimental quantum optics in 2007. Since 2012 he is scientific and managing director of the Hanover Centre for Optical Technologies (HOT) and since 2014 professor of physics at the Leibniz University Hanover. His scientific activities include applied and fundamental research in laser development and spectroscopy, polymer optical sensing as well as optical technology for illumination, information technology and the life sciences.



Prof. Dr.-Ing. habil. Steffen Lochmann

e-mail: steffen.lochmann@hs-wismar.de

Steffen Lochmann graduated at the Technical University of Dresden, Germany with a major on electronics technology in 1981 and he received a Ph.D. from Humboldt University of Berlin, Germany in 1984, where he worked on passive optical fibre Components. In 1993, he also received the Dr.-Ing. habilitas degree from the Humboldt-University of Berlin. Since 1997 he has been a full professor at the Hochschule Wismar, Germany. His current research includes optical fibre sensors and networks, code division multiplexing and optical MIMO technologies.



otrzymano/received: 14.06.2016

przyjęto do druku/accepted: 01.07.2016

