

ANDRZEJ NOWROT
KRZYSZTOF KAMIL ŻUR
ANNA ŚWIDERSKA-ŚRODA
MONIKA MIKOŁAJCZYK
WITOLD ŁOJKOWSKI

Autonomous fiber-optic gas monitoring system with thermoelectric power supply

This paper presents the concept of an autonomous measuring instrument powered by a locally accessible source of heat with a contact surface area of over a dozen or several dozen cm² and a temperature higher or lower than the ambient temperature. The design and construction of the measuring device will be based on two modules developed and constructed in the course of previous work: a dedicated low-power thermoelectric generator and luminescent fiber-optic detector. The system can be additionally equipped with a wireless transmission module. The studies show that, due to the power supply and photoluminescent measurement system with high stability of the operating point, this device will be capable of continuous operation without maintenance for many months.

Key words: *gasometry, thermocouple, nanotechnology*

1. INTRODUCTION

The commissioning of new equipment in a measuring network under industrial conditions requires the provision of adequate power and communication interfaces. In many applications, it is embarrassing because of the need for new power and teletransmission wires (after the installation project). The best solution for low-power measuring devices that work on the ground and in open space is the use of wireless transmission and a hybrid power supply based on batteries and photovoltaic cells. This solution can be partially used in underground mines, except that the photovoltaic cell will be replaced by a thermoelectric cell. The simplest thermoelectric module, which converts heat flux into electricity, is based on the Seebeck effect. Elements of this type are commonly used in small refrigeration units, where they occur in the Peltier phenomenon (which is the reverse of the Seebeck phenomenon). The same trade name module (“Peltier Module”) can be used as either a cooling element (one side of a module cools and another heating up) and an electric generator as a result of the flow of heat

flux through the module due to an externally forced temperature difference between its pages. The Peltier and Seebeck phenomena have been known in the field of physics since the beginning of the 19th century; they are discussed more extensively in works [1, 2–4].

The measuring part of the proposed device will be based on a fiber-optic detector. It is a completely non-electric element at the place of measurement, which is very important when working in an explosive atmosphere.

In this paper, we present a detector of oxygen content in the atmosphere – OSE (Oxygen Sensor Effect). Its operating principle uses the unique properties of nanocrystalline zirconium dioxide doped with europium, obtained by microwave hydrothermal synthesis. More information about the properties and obtaining the nanomaterial are included in paper [5].

The detection material – ZrO₂:Eu³⁺ nanoparticles struck by a UV light beam at a 405 nm wavelength, and the UV beam is diffused. In addition to UV in the reflected spectrum, there are red and near-infrared signals from the luminescence in a range of about 580–720 nm, whose intensity depends on the concentration of oxygen. An increase in the oxygen

content of the gas/atmosphere mixture results decrease in photoluminescence intensity. The presented method of measuring oxygen concentration has been patented by Polish and European patents [6, 7].

2. CONCEPT OF FIBER-OPTIC SENSOR POWERED BY THERMOELECTRIC GENERATOR

Figure 1 shows a block diagram of a thermoelectric cell measuring device with an external measuring chamber connected to two optical fibers. In the course of previous work, demonstrators of the most-important modules of the device were constructed, including:

- a thermoelectric generator based on the Seebeck phenomenon with a dedicated, stabilized DC/DC converter,
- a fiber-optic photoluminescent gas detector.

The proposed fiber-optic detector is a low-power consumption measuring system that can cooperate with the constructed thermoelectric generator.

The other modules (radio transmitter and low-power microcontroller) will be based on commercially available components and standard equipment used in industrial equipment. Additionally, the voltage stabilizer integrated in the inverter has a SuperCap-type capacitor characterized by high electrical capacitance. Its presence will allow the device to obtain instantaneous electrical power many times greater than the value of the continuous power of the thermoelectric cell (e.g., during radio transmission of data packets in increased power/range mode). The SuperCap exploitation will be controlled by the microcontroller through power transistors. The blue frame on the diagram in Figure 1 indicates the stationary part of the unit that will be installed/built in a place where it is possible to obtain a difference in temperature and heat flux.

A measuring chamber contains detection material that is connected to a stationary member via a fiber-optic cable, which may be several meters or even kilometers in length depending on the fiber type used. The experimental version of the system uses a multi-beam optical fiber cable with a length of about two meters. The UV wave is produced by a UV LED 405-nm diode.

The detection part consists of two semiconductor photodetectors, preceded by optical filters. The first

detector measures light in the UV area that has been previously dispersed in the measuring chamber on the detection material. The sensitivity area of the second detector ranges from 580 nm to 640 nm or 600 nm to 640 nm and is associated with photoluminescence produced in the detection material. Thanks to the UV level measurement, a reference signal is provided that allows the instrument to autocalibrate at almost any time.

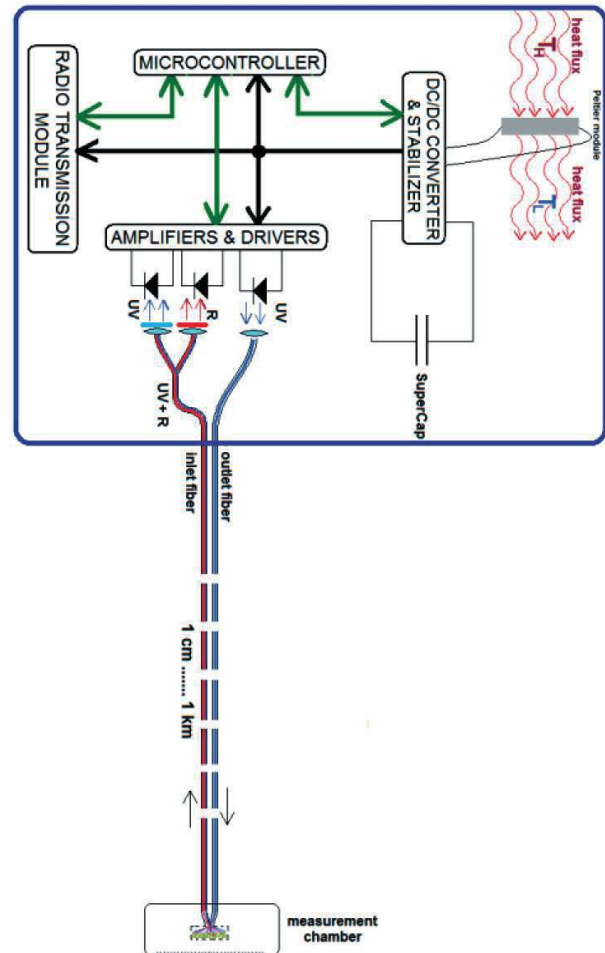

Fig. 1. Block diagram of measuring device powered by thermoelectric cell with outer fiber-optic measuring chamber

3. THERMOELECTRIC GENERATOR BASED ON PELTIER MODULE

The construction of the thermoelectric generator has been based on commercially available Peltier modules, which are mainly intended for refrigeration equipment. Three modules (each with 30.0 mm × 30.0 mm × 3.3 mm dimensions) were electrically connected in a series structure. Figure 2 shows an infrared image of the mea-

suring system to determine the electrical characteristics of a single module as an electric generator. Based on the images in Figure 2, the temperature of both sides of the Peltier module (which was the Seebeck phenomenon) was measured in each case.

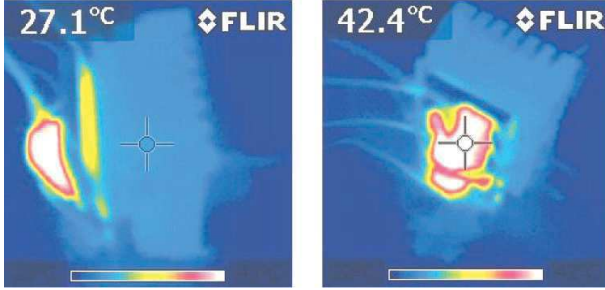

Fig. 2. Infrared images of measuring system for determining electrical characteristics of single module as electric generator

The chart in Figure 3 shows the electrical power output of a single Peltier module operating as a thermocouple for various load resistances and a temperature difference between the Peltier module sides of 30.3°C.

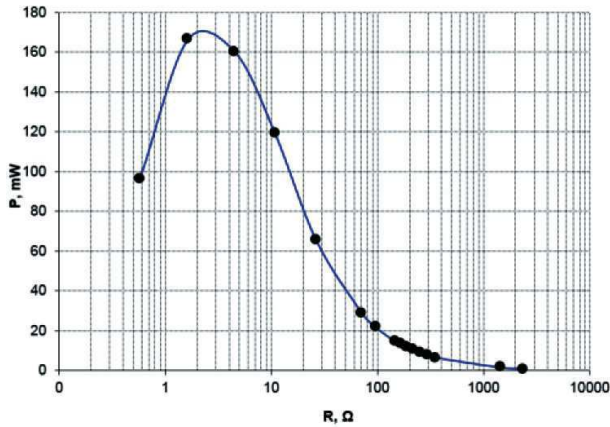

Fig. 3. Electrical power generated by Peltier module during conversion of heat energy to electrical energy for different load resistance (results for temperature difference between module sides 30.3°C)

The highest output power is obtained for a load resistance of about 2–3 Ω. It was necessary to develop a dedicated stabilized DC/DC converter equipped with a SuperCap energy cartridge to keep the module working around its maximum electrical power.

The maximum electrical power obtained from the Peltier module per unit of its transverse surface (through which perpendicularly penetrates the heat flux) during operation as a thermocouple depends strongly on the temperature difference between its

sides (as illustrated in Fig. 4). The single Peltier module surface area is 9 cm² (one side).

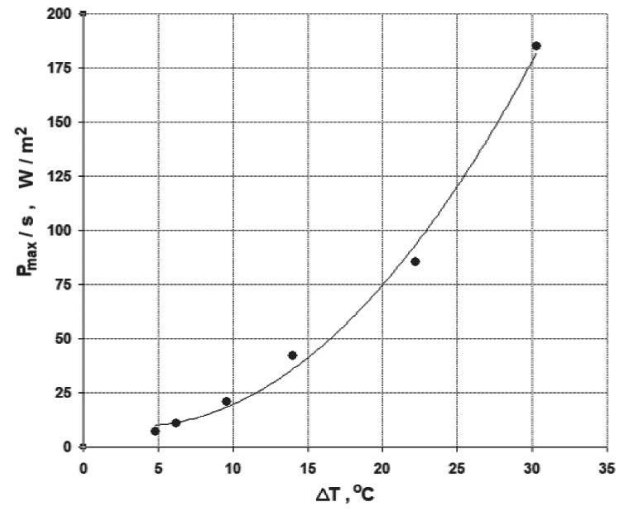

Fig. 4. Electrical power produced per surface area unit of Peltier module in which conversion of heat energy to electricity occurs depending on temperature difference between sides of module

The measurements results indicate that for a temperature difference of about 30°C (K) between the sides of the Peltier (Seebeck) module and the current technological level of the manufactured modules, the electric power is over 180 Watts. The electrical power produced by the module surface area unit may approximate to the second-degree polynomial or the following power function:

$$\frac{P_{\max}}{s} = A \cdot \Delta T^2 + B \cdot \Delta T + C \quad (1)$$

where:

$$\begin{aligned} A &= 0.24 \text{ (0.04) W/(m}^2 \cdot \text{K}^2), \\ B &= -1.7 \text{ (1.5) W/(m}^2 \cdot \text{K)}, \\ C &= 13 \text{ (10) W/m}^2 \end{aligned}$$

$$\frac{P_{\max}}{s} = A \cdot \Delta T^B \quad (2)$$

where:

$$\begin{aligned} A &= 0.16 \text{ (0.08) W/(m}^2 \cdot \text{K}^B), \\ B &= 2.07 \text{ (0.16) Log}_k \text{ (W} \cdot \text{m}^2 \cdot \text{A}^{\circ 1}). \end{aligned}$$

Considering the high uncertainty of the values of some coefficients in Equations (1) and (2), it can only be stated that both matches clearly indicate the nature of dependency $\frac{P_{\max}}{s} \sim \Delta T^2$.

4. PHOTOLUMINESCENT GAS DETECTOR

The measuring chamber is a completely non-electric device. Figure 5 shows the chamber demonstrator, which is the starting point for the construction of its industrial version. The analyzed gas enters the detection cavity via a 4-mm-diameter tube. This process can be forced by injection of a gas mixture or by self-diffusion. Depending on the alignment of the calibration elements of the chamber, the detection process is performed in a cavity with a volume of about 1 cm^3 . The industrial version of the device will radically reduce the external dimensions of the chamber and replace the intake tube to a flat ceramic filter, which will significantly reduce the diffusion time of the gas entering the chamber. The material of which the chamber housing has been made (stainless steel) will be finally adapted to the requirements of explosive atmospheres; i.e., any impact on the enclosure of the device cannot generate a spark. To the chambers of Figure 5, two groups of optical fibers were connected in accordance with the idea in Figure 1.

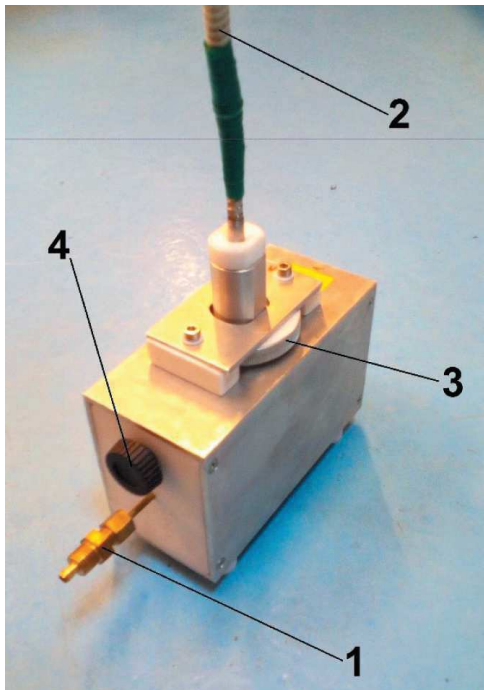

Fig. 5. Measuring chamber: 1 – inlet of measured gas; 2 – fiber-optic armature; 3 and 4 – calibration screws. External dimensions of rectangular part of chamber: $170 \text{ mm} \times 100 \text{ mm} \times 70 \text{ mm}$

They are included in one armor – apparently, only one fiber is connected. The detection material – ZrO_2 nanoparticles: Eu^{3+} (5% mol) – is a tablet (obtained

by compression) with a diameter of 7 mm and thickness of 0.2 mm. The nanoparticles contained in the pellet have an average size of about 10 nm. UV light causes photoluminescence in the detection material, which is dependent on the level of oxygen.

Figure 6 shows an example of the luminescence signal produced in the detection material placed in the chamber in Figure 5 and illuminated with a wavelength of 405 nm.

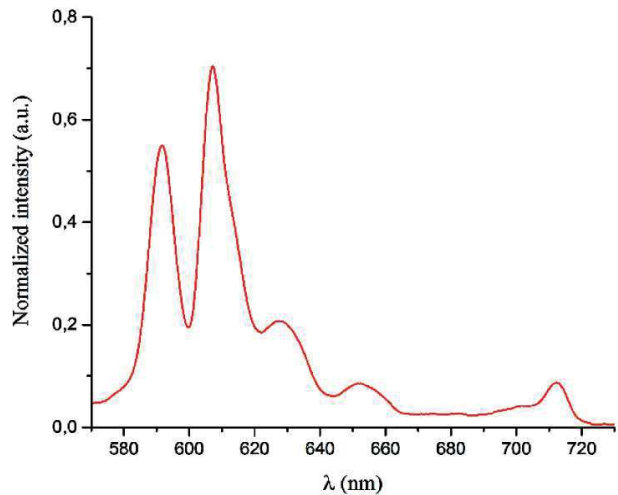

Fig. 6. Luminescence signal of $\text{ZrO}_2:\text{Eu}^{3+}$ tablet obtained in laboratory atmosphere (without gas flow, at room temperature) [5]

The location of the individual extremes corresponds to the colors red and near infrared. This is due to the electron transitions characteristic for Eu^{3+} ions deposited in the ZrO_2 nanocrystalline matrix.

The height of the peaks and value of the surface area under the curve in Figure 6 in the assumed range (the luminescence intensity integral) depends on the concentration of oxygen, and the optical signal is measured in the stationary part of the device. Depending on the optical filter available, a measurement wavelength range of 580 nm to 640 nm or 600 nm to 640 nm was used [8, 9].

The characteristics in Figure 7 illustrate an example response of a system defined as the integrated luminescence intensity for step changes in the concentration of oxygen that is detected by this gas detector. The most-advantageous detection range of the luminescence signal is a wavelength of 600 nm to 640 nm, since the spectrum in this respect is most-sensitive to changes in the environment around the europium ions.

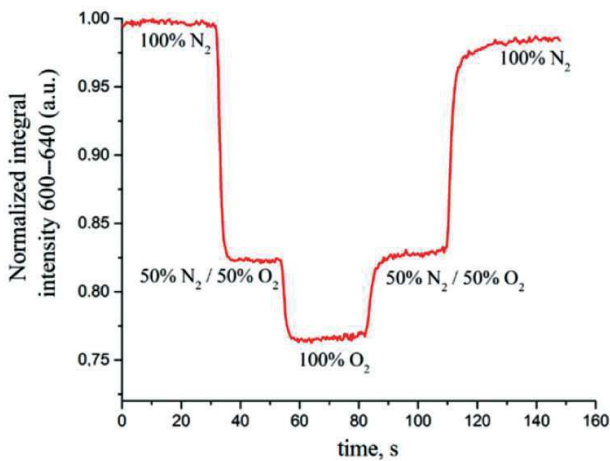

Fig. 7. Value of normalized integral of intensity of luminescence (in range of 600 nm to 640 nm) during changes in oxygen content in measuring chamber shown in Figure 5

The changes in luminescence in the detection material as a result of the change in the composition of atmosphere occur over several dozens of milliseconds. The few seconds of rising or falling times of the recorded signal in the characteristic of Figure 7 result solely from the time of penetration of the gas under testing into the measuring chamber. The penetrating time will be shortened if the entrance tube (1) (shown in Fig. 5) is removed. The changes in the luminescence intensity integral value are not directly proportional to changes in the concentration of oxygen in the analyzed atmosphere. The detection material exhibits slightly higher sensitivity for oxygen concentrations of the order of a few to a dozen percentage points. This causes the 50% concentration of the luminescence concentration to not be halfway between the 0% and 100% concentration levels in Figure 7. An important sensory property of the nanocrystalline material depicted is the speed of its reaction to changes in the oxygen concentration in the atmosphere. The optical response time of the measurement system is less than several tens of milliseconds. This depends of the dynamics of the luminescence-quenching process in the nanomaterial. For industrial applications, the reaction time constant or time t_{90} depends only on the diffusion time or forced penetration of the gas into the inside of the measuring chamber and travel time through the dust filter. The diffusion penetration time or time constant are similar to methane detectors with infrared absorption – more than ten seconds.

5. SUMMARY

The research and development work done shows that the current technological level of thermoelectric modules allows them to be used as power-measuring devices. The conversion of heat to electricity can take place only where there is a heat flux (or one can be generated). Therefore, it is proposed to use an external measuring chamber that can be located at almost any distance from the stationary part. The use of photoluminescence in nanoscale zirconium dioxide doped with europium to measure oxygen concentration has completely eliminated the electrical components in the measuring chamber and optical signals between the chamber and stationary part of the device (which are transmitted only by optical fibers). The adopted way of self-calibration allows us to receive high stability and to avoid maintenance for many months. The results of the temperature tests (not presented in the paper) of the detection material indicate that its structural and chemical composition stability are within a temperature range of -40°C to 300°C . Thanks to this, the application field of the device under industrial conditions is very wide. The heat generated by the machines due to their imperfections and technological processes can be used for more than powering measuring instruments [2–4]. The concept of the measuring instrument adopted in the paper is the starting point for the construction of an industrial version of this device.

References

- [1] Goldsmid H.J.: *Introduction to Thermoelectricity*, “Springer Series in Materials Science” 2016, 121: 1–24.
- [2] Viswanathan V.V., Davies R.W., Holbery J.: *Opportunity Analysis for Recovering Energy from Industrial Waste Heat and Emissions*, Pacific Northwest National Laboratory, Richland 2006.
- [3] Dunham M.T., Barako M.T., LeBlanc S., Asheghi M., Chen B., Goodson K.E.: *Power Density Optimization for Micro Thermoelectric Generators*, “Energy” 2015, 93: 2006–2017.
- [4] Cao Z., Koukharenko E., Tudor M.J., Torah R.N., Beeby S.P.: *Flexible screen printed thermoelectric generator with enhanced processes and materials*, “Sensors and Actuators” 2016, 238: 196–206.
- [5] Smits K., Grigorjeva L., Millers D., Sarakovskis A., Opalinska A., Fidelus J.D., Łojkowski W.: *Europium doped zirconia luminescence*, “Optical Materials” 2010, 32: 827–831.
- [6] Polish Patent PAT.218574: *Sposób pomiaru zawartości tlenu w gazie*, <http://regserv.uprp.pl/register/application?number=P.393942>.

- [7] European Patent EP2686669: *Method of measuring of oxygen content in gas*, <https://register.epo.org/application?number=EP12715721>.
- [8] Yen W.M., Shionoya S., Yamamoto H.: *Phosphor Handbook*, CRC PRESS 2006.
- [9] Lakowicz J.R.: *Principles of Fluorescence Spectroscopy*, Springer 2006.

ANDRZEJ NOWROT, Ph.D., Eng.
MONIKA MIKOŁAJCZYK, Eng.
Department of Electrical Engineering
and Automation in Industry
Faculty of Mining and Geology
Silesian University of Technology
ul. Akademicka 2, 44-100 Gliwice, Poland
andrzej.nowrot@polsl.pl
monika.miko@onet.pl

KRZYSZTOF KAMIL ŻUR, Ph.D., Eng.
Faculty of Management Engineering,
Białystok University of Technology
ul. Wiejska 45A, 15-001 Białystok, Poland
Laboratory of Nanostructures
Institute of High Pressure Physics
Polish Academy of Science
ul. Sokołowska 29, 01-142 Warszawa, Poland
k.zur@pb.edu.pl

WITOLD ŁOJKOWSKI, Prof.
ANNA ŚWIDERSKA-ŚRODA, Ph.D., Eng.
Laboratory of Nanostructures
Institute of High Pressure Physics
Polish Academy of Science
ul. Sokołowska 29, 01-142 Warszawa, Poland
{wl, annas}@unipress.waw.pl