

## **PREDICTING BENDING MOMENT IN CROWN OF SOIL-STEEL STRUCTURE BUILT AS ECOLOGICAL CROSSING FOR ANIMALS**

Marcin MUMOT\*  
Politechnika Wrocławska  
Instytut Inżynierii Łądowej

The paper concerns soil-metal structures made of a thin shell (usually - corrugated steel) and soil backfill. During backfilling significant deformations of the structure can be observed (the upper part of the shell buckles and its width narrows). This phenomenon results in a subsequent prestressing effect during placing the backfill material above the crown of the structure. In the paper the method of bending moment determination in the crown of the structure, which is the main component affecting stresses in the steel shell, is proposed. The results obtained using in-situ method were compared with the results obtained using FEM software. The conclusions were drawn and the diagrams presenting the curvatures necessary to estimate values of the bending moment in the crown of the structure were obtained from the studies. Relations that could help in development of the methodology for determining internal forces in the crown of the structure of different geometry were found. The studies will help in designing of that type of structures and will allow to prevent critical forces in the steel shells during the erection process.

Keywords: soil-steel structures, ecological crossing, corrugated steel, soil backfill, deformation, bending moment.

### **1. INTRODUCTION**

Experiences in designing and fabrication of corrugated metal structures show that the largest bending moments can be observed during construction. Internal forces in the metal shell during backfilling, when the level of the backfill material is equal to the height of the crown of the structure, are ever ten times larger than during the entire lifetime of the structure. Therefore, an exact

---

\* Corresponding author. E-mail: [marcin.mumot@pwr.wroc.pl](mailto:marcin.mumot@pwr.wroc.pl)

determination of the internal forces in the shell is an important issue in the designing process of the soil-metal structures. It was observed that bending moments (which are the main component of stresses) can be determined based on the change of the curvature in the crown of the shell. This paper presents computer analysis carried out in order to verify the correctness of this method and to observe relations necessary to determine correctly the values of bending moments in soil-metal structures. There are three basic shapes of the lightweight shells: open bottom A, closed bottom B and frame C.

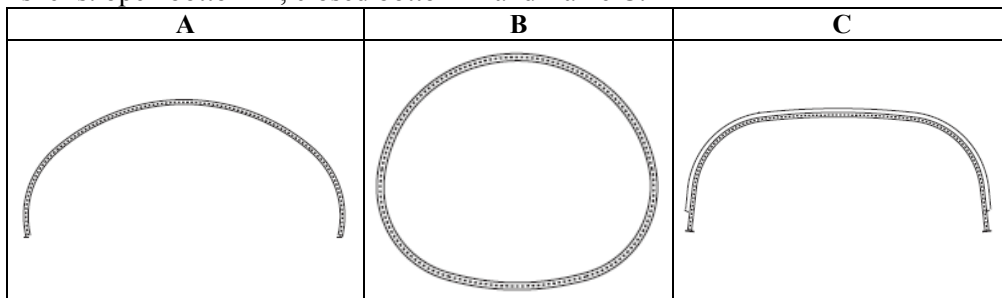

Fig. 1. Characteristic types of the shells

Structures A and B behave in the similar manner during backfilling, their deformations are similar to the drawing in Figure no. 2. This paper does not concern box structures –type C, because these are non-standard structures and their deformation is different than in traditional structures.

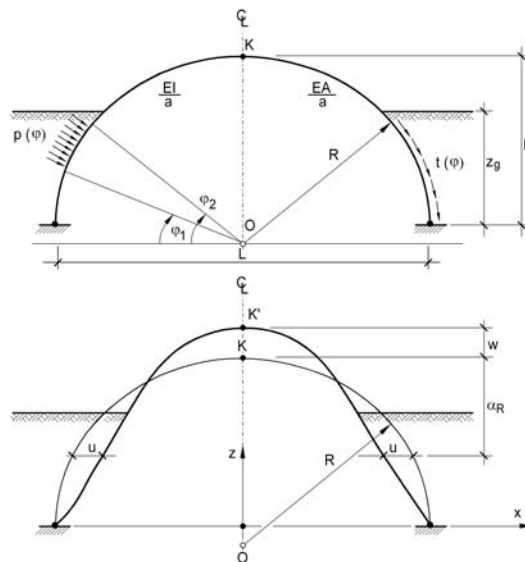

Fig. 2. Basic parameters of the shell and its deformation, typical for soil-steel arch structures

## 2. DEFORMATION OF SHELL DURING BACKFILLING

Two typical displacements can be distinguished in soil-metal structures. The basic displacements are: upward vertical displacement of the shell “w”, measured in the highest point and horizontal displacement “u”, where 2u is the shrinkage of the shell. As long as the level of the backfill is lower than the shell crown height we can observe an increase of the displacements A up to the height of the structure  $z_g = h$ , when the value of the upward displacement attains its maximum – K. However when the backfill material level is above the crown of the shell, stresses are reduced E to the moment of loss of stability (Fig. 3)

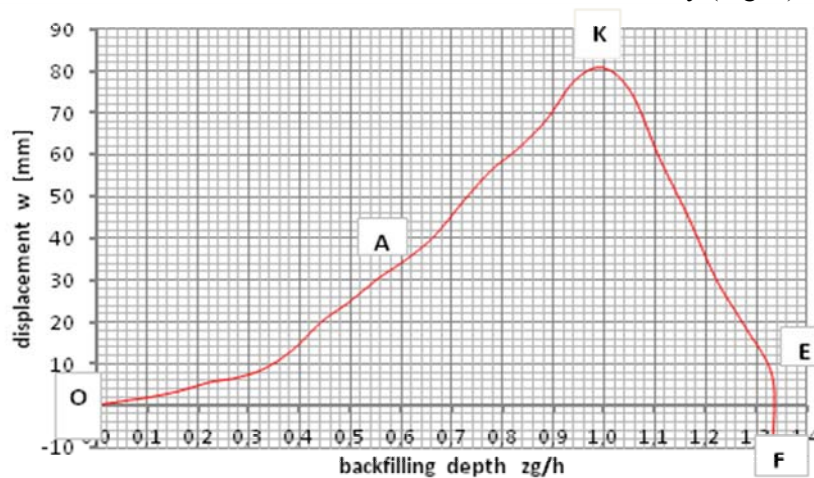

Fig. 3. Diagram of the displacements in the shell crown

The diagram show that the most dangerous stage of the soil-metal structure’s construction is when the level of the backfill material is equal to the height of the crown of the structure. Current methods of determining bending moments in such structures do not guarantee obtaining exact values of the internal forces [2]. It was observed, however, that the bending moment can be calculated based on the change of the radius of the steel shell curvature (1) [1].

$$\Delta R = R - R_{uw} \quad (1)$$

$R_{uw}$  – radius of curvature in the deformed steel shell,  
 $R$  – design radius of curvature of the steel shell.

In order to determine a change of the radius of curvature it is necessary to interpret properly horizontal and vertical displacements of the shell. The vertical displacement in the crown should be reduced by subtracting the value of the vertical displacement in points of shrinkage measurement (2).

$$w_k = w - w_p \quad (2)$$

$w$  – vertical displacement in the shell crown,  
 $w_p$  – vertical displacement in point of shrinkage measurement.

For the calculations a value of the coefficient  $\alpha$  is also required. The coefficient is calculated as follows (3):

$$\alpha = \frac{(h-z_g)}{R} \quad (3)$$

$h$  – design height of the structure,  
 $z_g$  – total thickness of the backfill layer,  
 $R$  – design radius of curvature of the steel shell.

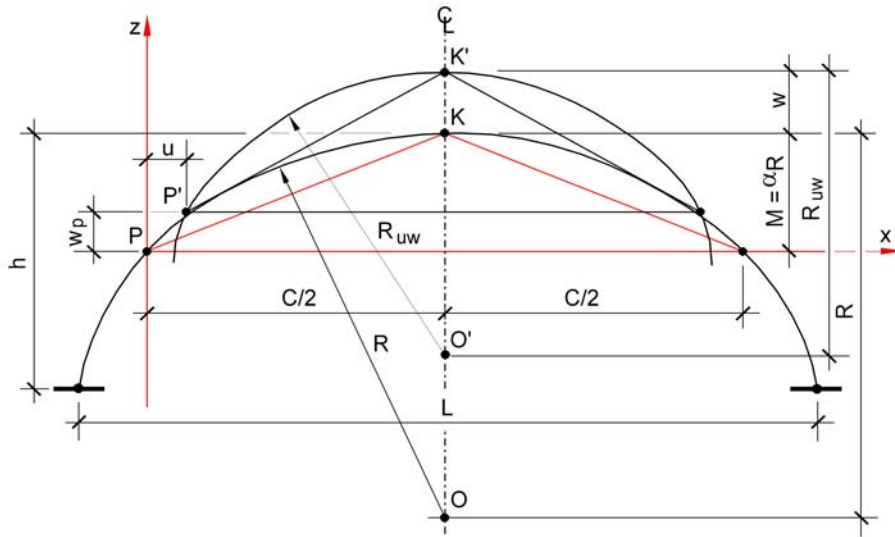

Fig. 4. Graphic scheme of the radius of curvature changes

Knowing the displacements of the shell, changes of the radius of curvature can be determined by transforming the formula for the radius of the circle (4):

$$R = \frac{4M^2 + C^2}{8M} \rightarrow dR_\alpha(z_g) = R - R_\alpha = \frac{R[w_k(1-\alpha) + u\sqrt{\alpha(2-\alpha)}]}{\alpha R + w_k} \quad (4)$$

Knowledge of the radius of curvature of an arc can be simply used to determine the maximum bending moment in a structure (5).

$$M = \frac{EI}{R} * \frac{dR}{R-dR} \quad (5)$$

In order to ensure the accuracy of the calculations, shrinkage measurement should be carried out at points situated at the level of backfill or above it. These are formulas for the loading scheme that does not include vertical earth pressure, because the radius of curvature is assumed constant and

vertical earth pressure would prevent that situation. In order to verify that method of determination of the internal forces in the steel shell, the field measurements of the assembled structure and the computer calculations by FEM software - Plaxis were carried out.

### 3. VERIFICATION OF THE BENDING MOMENT DETERMINATION METHOD IN THE SOIL-STEEL STRUCTURES

On the assembled structure (geometry presented in the Figure 5) some points were determined in order to determine bending moments.

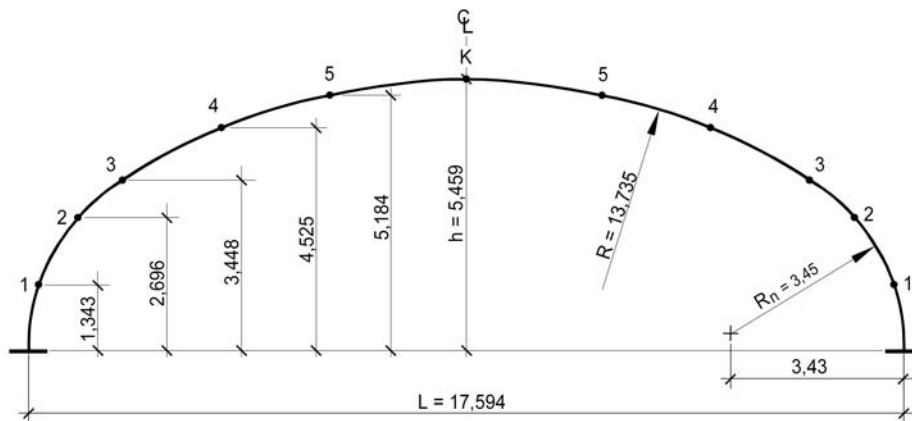

Fig. 5. Locations of the measurement points and shell geometry

6 measurement points were selected but because of the calculation method (measurement points should be located on the arc of the same curvature) points 1 and 2 have been omitted in considerations and points 3,4,5 and K were used to determine the bending moment. Procedures of calculation and internal forces determination is described in the paper [1]. The diagram presenting changes of the curvature depending on measurement point looks like in the presented diagram [diagram 1]. A significant influence of the vertical loads can be observed on this diagram. Up to the moment when the measurement points are above the backfill level, deformation diagrams are convergent, with additional layers of the backfill material the diagrams “move away” from each other. Therefore, to compare results the highest measurement point was selected, for which  $\alpha=0.02$ . By selecting that point for further consideration the influence of vertical earth pressure can be minimized. A change of the radius of curvature for that measurement point when  $z_g = z_u$  ( $z_g/h = 0.9497$ ) equals 9.890%, while the maximum value of the shell deformation equals about 11%.

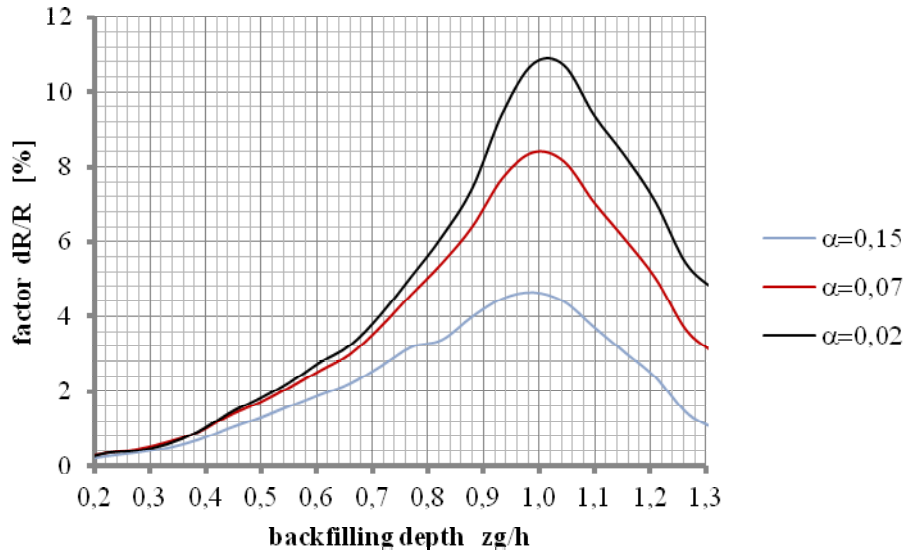

Diagram 1. Change of the radius of curvature depending on backfill height

In order to compare the obtained results a FEM model was created using Plaxis3D software. The modelled shell presents the actual geometry of the structure in the most accurate way and the soil parameters are assumed in accordance with the actual conditions. The following soil parameters were assumed  $E=40,0\text{MPa}$ ,  $\nu=0,3$ ;  $\gamma=20,0\text{kN/m}^3$ . For modeling a shell made of the 7 mm thick SuperCor corrugated steel was assumed. Young's modulus of steel is 210 GPa,  $\nu=0,3$ .

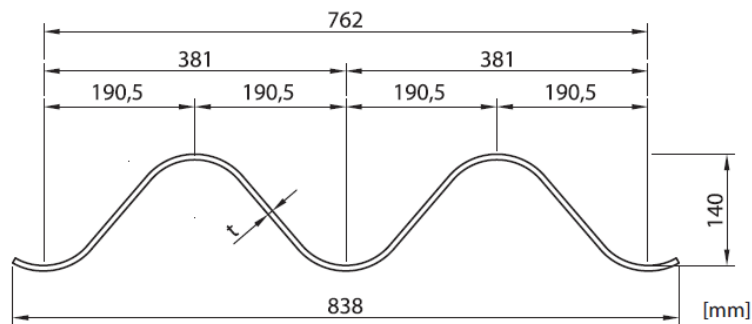

Fig. 6. Cross-section the SuperCor

24 stages of backfilling were modelled and non-linear behaviour of the structure was assumed. The support of the structure is linear, modelled as a concrete spread footing foundation of 0,5 m thickness.

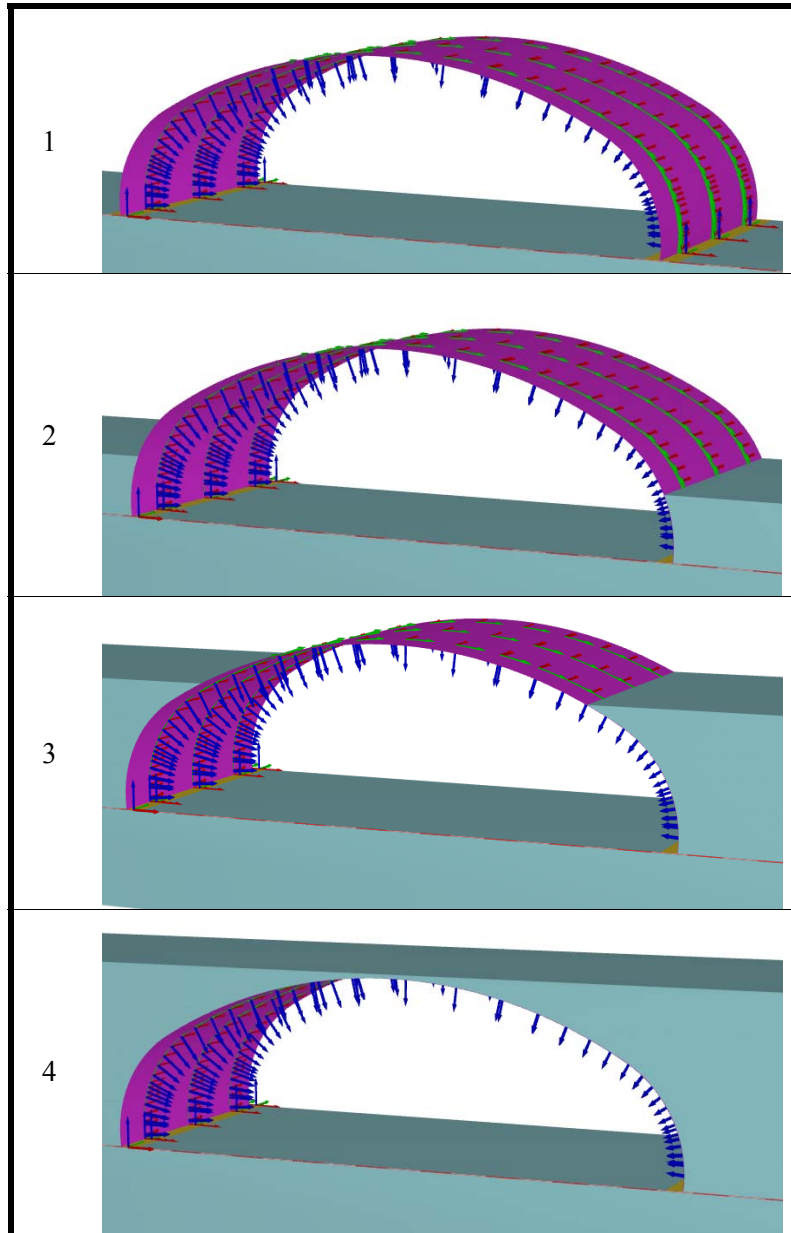

Fig. 7. Selected stages of backfilling

Values of the deformations and bending moments in the crown of the structure can be interpreted from the model. All the results were summarized in the table and the diagrams were drawn. Bending moments in the crown of the

shell in the middle of its width and the shrinkage value at the point for which  $\alpha=0,002872$  are presented.

Table 1. Data obtained by using FEM software

SC-27NA					
$z_g$ [m]	$\alpha$	$M_{FEM}$ [kNm]	$M_{displ}$ [kNm]	$\Delta_{FEM}$ [%]	$\Delta_{displ}$ [%]
0	0,378	0,000	0,000	0,00	0,00
0,3	0,357	-0,083	-0,102	-0,03	-0,03
0,6	0,335	-0,151	-0,180	-0,05	-0,05
0,9	0,314	-0,193	-0,230	-0,06	-0,07
1,2	0,292	-0,198	-0,239	-0,06	-0,07
1,5	0,271	-0,153	-0,197	-0,05	-0,06
1,8	0,249	-0,044	-0,085	-0,01	-0,03
2,1	0,228	0,159	0,119	0,05	0,04
2,4	0,206	0,543	0,506	0,16	0,15
2,7	0,185	1,225	1,200	0,37	0,36
3	0,163	2,331	2,318	0,71	0,71
3,3	0,142	3,982	3,918	1,22	1,20
3,6	0,120	6,352	6,164	1,96	1,90
3,9	0,099	9,664	9,385	3,02	2,93
4,2	0,077	13,864	13,505	4,38	4,27
4,5	0,055	19,048	18,714	6,12	6,01
4,8	0,034	25,102	24,797	8,23	8,12
5,1	0,012	31,485		10,54	
5,4	-0,009	32,742		11,01	
5,7	-0,031	29,777		9,91	
6	-0,052	26,930		8,88	
6,3	-0,074	24,332		7,96	
6,6	-0,095	21,880		7,10	
6,9	-0,117	19,572		6,30	
7,2	-0,138	17,463		5,59	



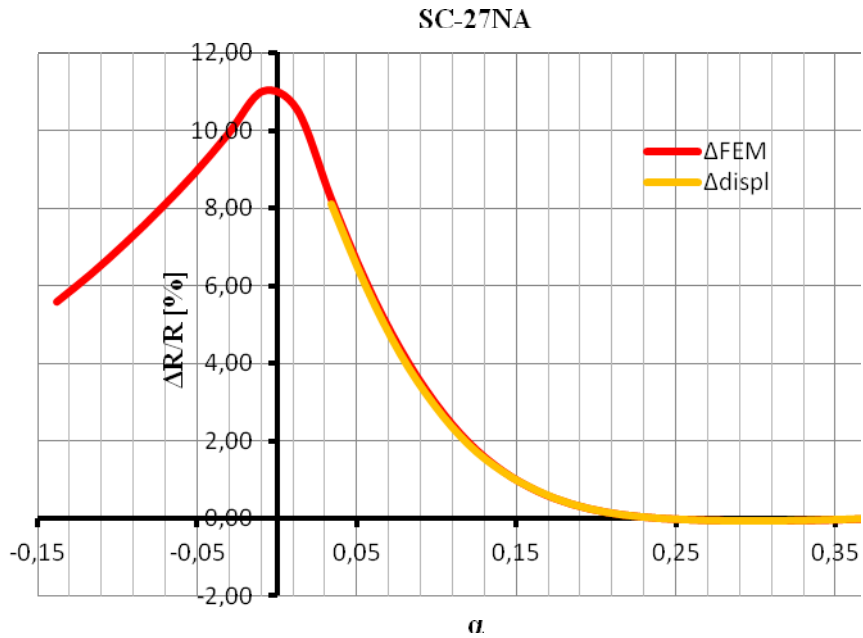

Diagram 2. Change of the radius of curvature depending on backfill height

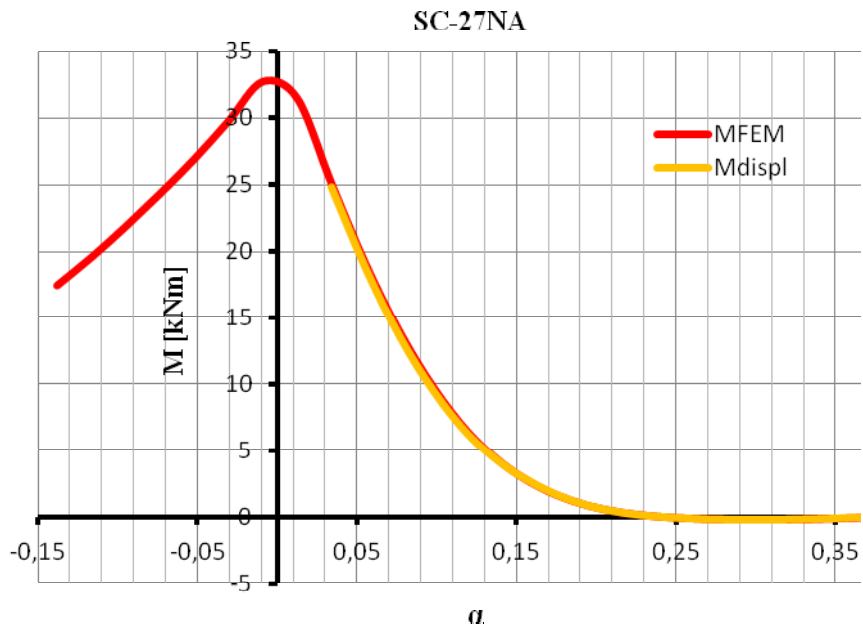

Diagram 3. Change of maximum bending moment depending on backfill height

It can be observed from the diagrams that the maximum value of the shell deformation in the crown of the structure equals about 11%. The exact value of the deformation could not be obtained, because the level of the last layer of the backfill material did not equal the shell height. Comparing the actual change of the radius of curvature with the results obtained from computer analysis it can be assumed that the presented method of bending moments determination is correct. In the paper [1] it was noticed that the curve describing the change of the curvature depending on the backfill height can be approximated (6). From these calculations results that the maximum deformation of the shell equals 12,16% and it was calculated using the formula:

$$dR_k^{\max} = dR_{\alpha} \left( \frac{h}{h - \alpha R} \right)^4 \quad (6)$$

The formula can be applied in order to reduce the influence of the vertical earth pressure on the shell deformation. The value can be used as a design value in order to provide a safety margin for the designed structure. The diagrams (2 and 3) show that strain measurements during backfilling and determination of the radius of curvature changes allow calculating the maximum bending moment. That regularity can be applied also in the opposite direction. Knowing the maximum value of bending moment (shell's deformation) it can be verified if the permissible values of forces are not exceeded during erection process, allowing the contractor to reduce bending moments and upward displacements of the shell, for example by placing ballast.

#### 4. OTHER CALCULATION MODELS

The test were also carried out for different shell shapes and for different shell stiffness. They have shown that the shell's stiffness has a great influence on its behaviour during construction. Soil-metal structures should be designed according to the guidelines described in the paper [3,4]. Following these guidelines should lead to an observation of radius of curvature deformation within the range 8-14 %. Designing of too thin or too stiff shell results in a risk that the vertical deformation in the crown will be too big and the plastic deformation will occur in the shell, in the latter case it leads to unnecessary oversizing of the structure. The diagrams (4,5) show changes of the radius of curvature depending on the backfill height (red line) and calculated displacements based on the deformations (yellow line). In spite of the different stiffness of the shells and their geometry, deformation curvatures have a similar shape.

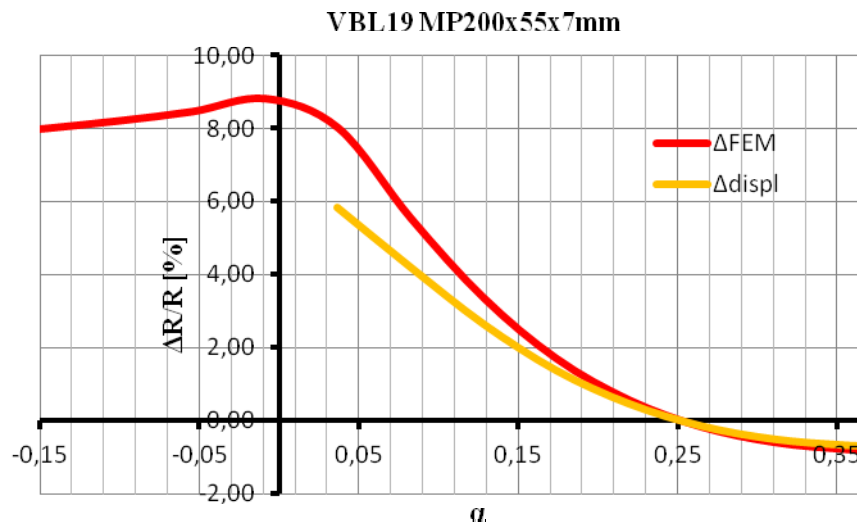

Diagram 4. Change of the radius of curvature depending on backfill height

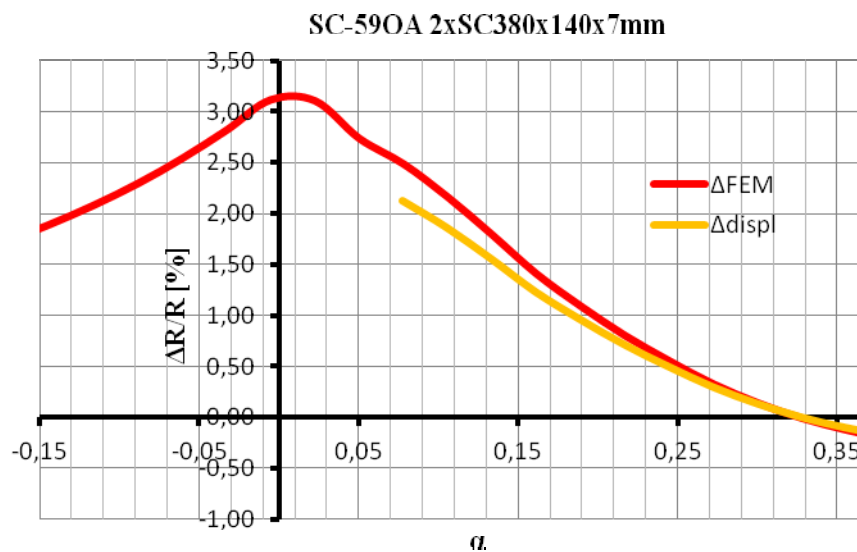

Diagram 5. Change of the radius of curvature depending on backfill height

However, graphs [6,7] show the change of deformation of similar shells [Fig. 8]. It can be observed that the change in stiffness does not cause the change of the deformation ratio between different shapes of shells. It can be noted that knowing the round-shape shell deformation we can assume deformation in other types of closed shells of similar dimensions. In both cases the difference between deformation of the shell VE 35 and VC 70 equals 45 % and between VE 35 rotated 90 degrees and VC 70 equal about 22 %.

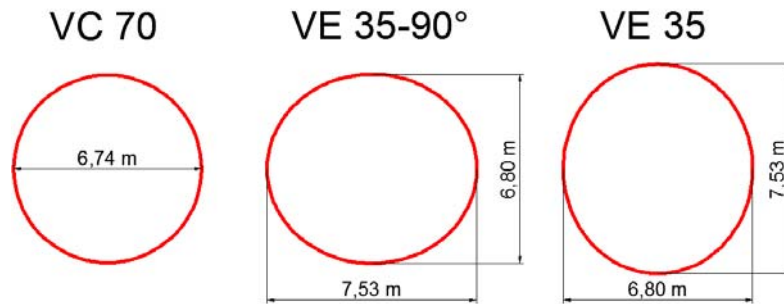

Fig. 8. Shapes and general dimensions of compared shells

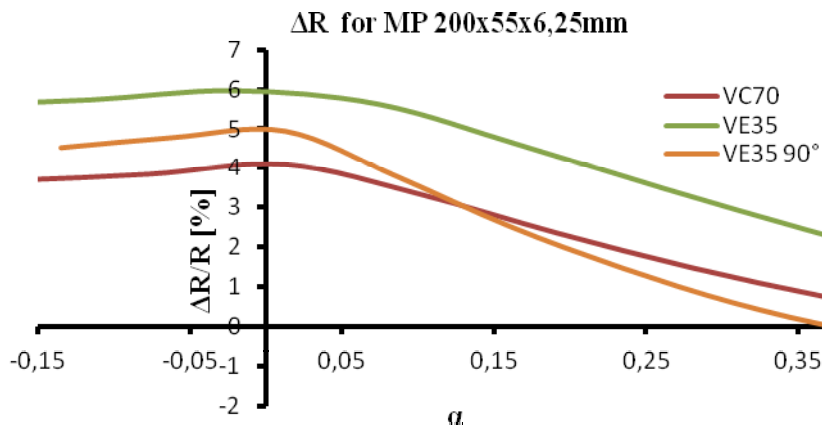

Diagram 6. Change of the radius of curvature depending on backfill height for a shell of 6,25 mm thickness

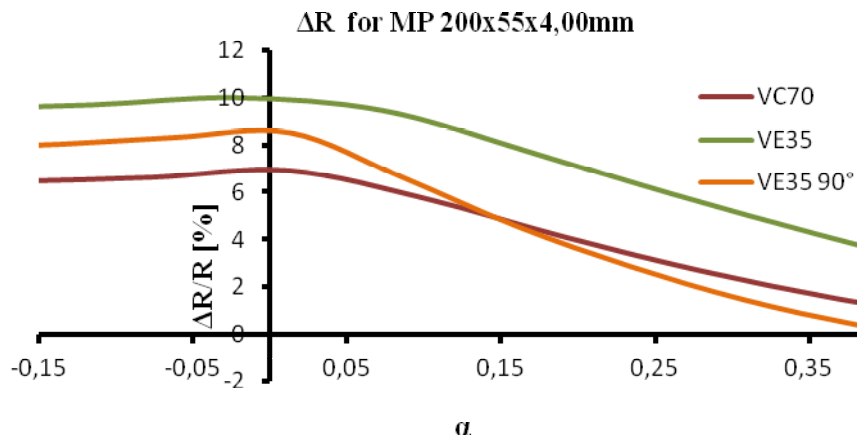

Diagram 7. Change of the radius of curvature depending on backfill height for a shell of 4,00 mm thickness

These examples show that there is a relation that could allow the correct determination of the radius of curvature in the crown of the structure for different shell shapes and for different spans. Unfortunately, it was noticed that change of the shell span results in changing of the determined proportions.

## 5. CONCLUSIONS

This paper draws attention to the occurrence of the maximum bending moment in the shell during backfilling. Presented calculations initiate the development of the methodology for determining internal forces in the crown of the shell. Insufficient accuracy of the current methods for determining internal forces was noted and a different method was proposed. In the paper a method for estimating of bending moments as a local effect of the global shell deformation was proposed. A procedure that allows correct determination of bending moments in the crown of the soil-metal structure was presented. The relations observed in results obtained from calculation models of that type of structures were presented and compared with the measurements performed on an actual structure. It is necessary to estimate correctly the deformation of the shell and to select a proper stiffness of the shell in relation to the span of the structure. A curvature shape was preliminary defined, according to which the maximum bending moment can be determined based on the measurements performed in the initial stage of construction. That method allows to predict exceeding of the critical force in the initial stage of construction and gives a possibility to reduce it (for example by ballasting shell).

## REFERENCES

1. Machelski Cz. Janusz L.: *Estimation of bending moments acting in the crown of a soil-steel bridge structure during backfilling*, ECCS European Convention for Constructional Steelwork, (2011). s. 1365-1370.
2. Antoniszyn G.: *Mostowe konstrukcje gruntowo-powłokowe : siły wewnętrzne w powłokach mostów gruntowo-powłokowych typu SUPER-COR*, Geoinżynieria, Drogi, Mosty, Tunele. (2008), nr 3, s. 58-60.
3. Machelski Cz.: *Modelowanie mostowych konstrukcji gruntowo-powłokowych*, Dolnośląskie Wydawnictwo Edukacyjne, Wrocław 2008.
4. Pettersson L.: *Full Scale Tests and Structural Evaluation of Soil Steel Flexible Culverts with low Height of Cover*, Doctoral Thesis, KTH , Sweden 2007.

PROGNOZOWANIE MOMENTÓW ZGINAJĄCYCH W KLUCZU KONSTRUKCJI  
GRUNTOWO-POWŁOKOWYCH BUDOWANYCH JAKO PRZEJŚCIA  
EKOLOGICZNE DLA ZWIERZĄT

Streszczenie

Praca dotyczy konstrukcji gruntowo-powłokowych wykonanych z wiotkiej powłoki (przeważnie blacha falista) oraz zasypki gruntowej. Podczas zasypywania konstrukcja deformuje się w znacznym stopniu (wypiętrza się góra powłoki i zwęża na szerokości). Zjawisko to przekłada się na późniejszy efekt sprężenia, gdy grunt układamy nad kluczem powłoki. W artykule zaproponowano metodę wyznaczania momentu zginającego w kluczu powłoki, który jest głównym czynnikiem wpływającym na naprężenia w stalowej powłoce. Wyniki otrzymane metodą in-situ zostały porównane z wynikami otrzymanymi w programie MES. Z badań nad różnymi kształtami powłok wyciągnięto wnioski oraz otrzymano krzywe potrzebne do szacowania momentów zginających w kluczu powłoki. Znaleziono zależności które pomogą w opracowaniu metodyki wyznaczania sił wewnętrznych w kluczu powłok o różnej geometrii. Badania pomogą projektować tego typu konstrukcje oraz pozwolą na zapobieganie występowania krytycznych sił w powłoce w trakcie budowy.