

## EFFECTIVE HARVESTING OF BRAKING ENERGY IN ELECTRIC CARS

Zdzisław Trzaska

*University of Ecology and Management in Warsaw  
Olszewska Street 12, 00-792 Warsaw, Poland  
tel. +48 22 8471005, fax: +48 22 8258031  
e-mail: zdzislawtrz@gmail.com*

### **Abstract**

*Regenerative braking and damping are effective approaches for electric cars to extend their driving range. A disk Faraday generator regenerative braking strategy integrated with controlled charging of a supercapacitor is developed in this article to advance the level of energy-savings on the car board. The kinetic energy of the car suspension during driving regenerated effectively to electric energy by using shock absorber is harvested and then used to charge the vehicle's battery, the power electronics and the supercapacitor. One of the advantages of supercapacitors is their high power capability, which is applicable for high rate of charging and discharging operations like motor starting and regenerative braking of an electric vehicle. This article presents a new charging method for supercapacitors. Common for regenerative braking and damping chargers for supercapacitors are usually equipped with electronic PWM converter performing two states of operation per switching cycle. A simple open-loop control system is applicable for the whole charging state. The proposed circuit consists of a minimum number of components. It is free of stability problem and protects itself from being overloaded by supercapacitor with zero initial charge. Simulation results for regenerative braking processes corresponding to three velocity tests are included.*

**Keywords:** *urban transport, environmental protection, electric cars, energy harvesting, braking energy recovering, damping energy recovering, supercapacitors, simulation*

### **1. Introduction**

Transport systems are now becoming the basis for integrating vital spheres of human activity in cities and regions, and for their analysis, planning, design and operational functioning in-depth diagnosis of transport system elements are essential. The transport sector is responsible for 21% of greenhouse gas emissions throughout the European Union countries. In accord with the European Union directive, the average CO<sub>2</sub> emissions of 95 g/km for all cars, with all passengers set, are fixed to reach in 2020, and 80 g/km is planned for 2030. Currently it is slightly below 120 g/km. Further reducing CO<sub>2</sub> emissions to 80% by 2050 will require 95% of the decarbonisation of the road transport sector. The recommended standards can be achieved only through adequate financing of strategies to increase the use of electric vehicles and the implementation of pilot electromagnetic mobility programs in cities. This requires the introduction of new technologies, mainly by putting into practice the general transport systems based on electrical vehicles and promoting the intensification of activities aimed at improving the economic situation and strengthening the protection of the environment in all European states [4, 6, 10].

Taking into account the above imperatives, presently many cars are designed to use only electricity as motive energy, which ensures high efficiency energy conversion and its transfer between different types of secondary energy sources. This is very important issue because of the need to take care of minimizing greenhouse gas emissions and the negative impact of urban transport on the environment. Moreover, the electric car makes possible to vary easily the driving speed and change load during traffic in the city and in non-urban areas [16].

It is worth to emphasize that in recent years great technical progress has been made in the areas of system structures and key component developments for electric vehicles, but there is still

a performance gap between electric vehicles and conventional vehicles with respect to driving range, energy saving and power car efficiency and passengers safety. However, the electric car has already become a technology that in the world market has successfully busted through the bastions so far dominated by vehicles driven by conventional combustion engines [11].

The global design of replacing an internal combustion engine into an electric motor can be compared in a very simplistic way with the past realization of the project of electrification of the railways when the electric locomotive turned the steam locomotive. However, the energy significance of the implementation of an electric car for road transport is much more significant than the electrification of railways. This is due, in part, to the fact that the Well-to-Wheel (WtW) energetic efficiency [21], counted from the extraction of energy resources to use of energy by the vehicle while driving on a road does not exceed 30% for combustion engine vehicles while in the case of an electric motor car already in the near future can be expected at 60%. Moreover, the WtW efficiency of small electric cars is more than 2.5 times than that of equivalent petrol cars. The energy is also saved by the fact that the electric car engine does not work when the car is standing and also because it can regenerate the braking energy and accumulates it in the battery, supercapacitor, flywheel and in pneumatic accumulator. This gives particularly large additional effects when moving in the city with very often stops at traffic lights or with traffic jams and that means significant lowering of costs in exploitations of electric cars [20].

It is now recognized that the tendency for electrification of road transport is at a stage of significant intensification and that this is an irreversible process and is particularly geared towards urban mobility. The justification for this statement is that every major automotive company has or is currently developing electrical models, and that a large number of countries have set significant plans to accelerate development and the deployment of electric vehicles. At the present stage of technical development, the use of electric vehicles is expected primarily for road transport in highly urbanized areas.

## **2. Energy losses in sub-systems of electric cars**

Currently, the production and operation of electric vehicles using integrated and efficient energy sources is seen as an important factor in ensuring the realization of urban transport at a low emission of harmful carbon compounds and noise signals. In order to achieve maximum utilization of the available energy during the operation of electric vehicles a full informative system and monitoring of inside and outside parameters as well as their constant modifications can be designed to reach maximal as possible energy efficiency during the city traffic. The most important possibilities for increasing energy efficiency of electric vehicles can be reached, regarding energy savings accumulated in the vehicle itself and increasing the range of performances of the cars with given initial resources. Nowadays, a progress in improving the energy efficiency of electric cars can be achieved by installing on the vehicle board a kinetic energy recovery system harvesting the energy under braking and vibrations or shocks generated from the road disturbances. Dampers or shock absorbers are the mechanical devices that are designed to absorb the shocks and minimize the vehicle vibrations. They are also installed to maintain the contact between the vehicle tires and road surfaces [3, 14, 15].

The recovered energy is stored in such reservoirs as an electrochemical battery and a supercapacitor for later use under acceleration. Once the energy has been harvested, it is stored in the reservoirs and released when required. Supercapacitors that provide high power density increase the acceleration of vehicle as well as collecting all the energy from instant braking; therefore, improvements of the characteristics of power supply are made [2].

Figure 1 illustrates some of the sub-systems in the electric car that experience energy losses during the driving on a road. The losses illustrated are energy being converted in the brakes and the dampers. Most of these losses are heat dissipating during mechanical processes, such as the friction and vibrations damping. Note, that in urban driving cycles a significant amount of energy is consumed by braking.

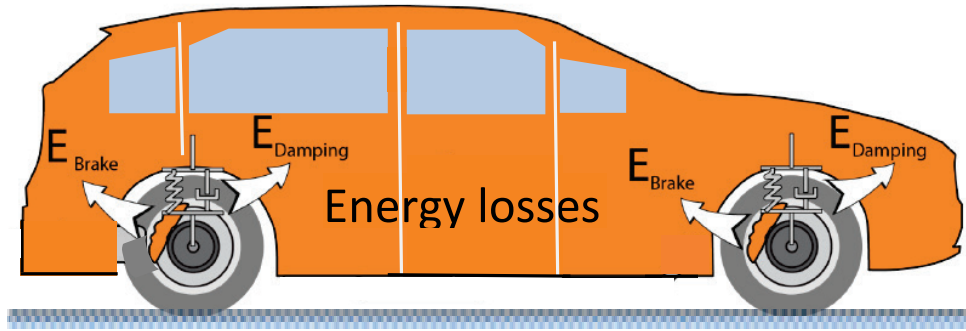

Fig. 1. Illustrative figure of some energy losses from sub-systems in a moving electric car

It is now expected that soon on the race tracks will be racing vehicles with electric motors, which emit low noise and are almost silent, and in a few moments will accelerate to over 300 km/h. Moreover, they will need less maintenance than complicated internal combustion race vehicles, that there are so far only in operation.

The dissipation of kinetic energy during braking and damping by an electric car can be recovered advantageously by controlling the power electronics for total energy management on board the vehicle. Therefore, regenerative braking and damping is an efficient technology to improve the efficiency of electric vehicles. Research indicates that substantial energy savings are in fact achievable, from 8% to as much as 25% of the total energy use of the vehicle, depending on the driving cycle and its control strategy (Fig. 2).

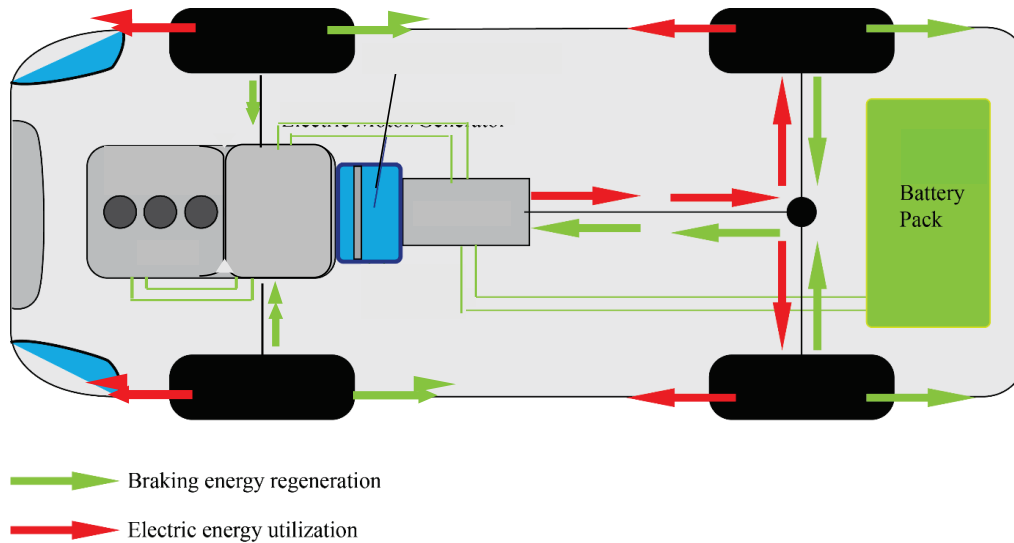

Fig. 2. Controlling the energy transfer in an electric car during traffic

One of the most effective methods for implementing energy harvesting is to convert kinetic energy produced by mechanical vibrations into useful electric energy, which can be stored in supercapacitors and then used to power sensors and/or active systems and/or on board auxiliary electrical loads.

### 3. Energy regeneration sub-systems in electric cars

#### 3.1. Preliminaries

To improve the performance of electric vehicles, the regenerative braking and damping sub-systems can be developed. The classic brakes, for example, are installed to provide means of decelerating the vehicle, thus helping with speed alteration. This is usually done by applying a brake

pad to a brake disc, which in turn creates friction and slows down the wheel (Fig. 3a). In this instance, the rotary kinetic motion of the wheel is turned into heat energy, which heats the brake discs. In the case of the damping system, it is designed to cushion the driver and passengers of the vehicle from the uneven road surface. When the damper moves up and down inside of the spring, kinetic energy is transformed into potential and thermal energies (Fig. 3b). However, most of this energy dissipates in the form of heat in the damper. It is obvious that all of these energy losses are unwanted. They are a by-product of the fact that energy can only be transformed and not destroyed, thus making it obviously preferable to have as low losses as possible. From the analysis of research conducted so far in a field it follows that two types of kinetic energy regeneration, i.e. systems with chemical accumulation and capacitive energy accumulation dominate over others of lesser importance [7].

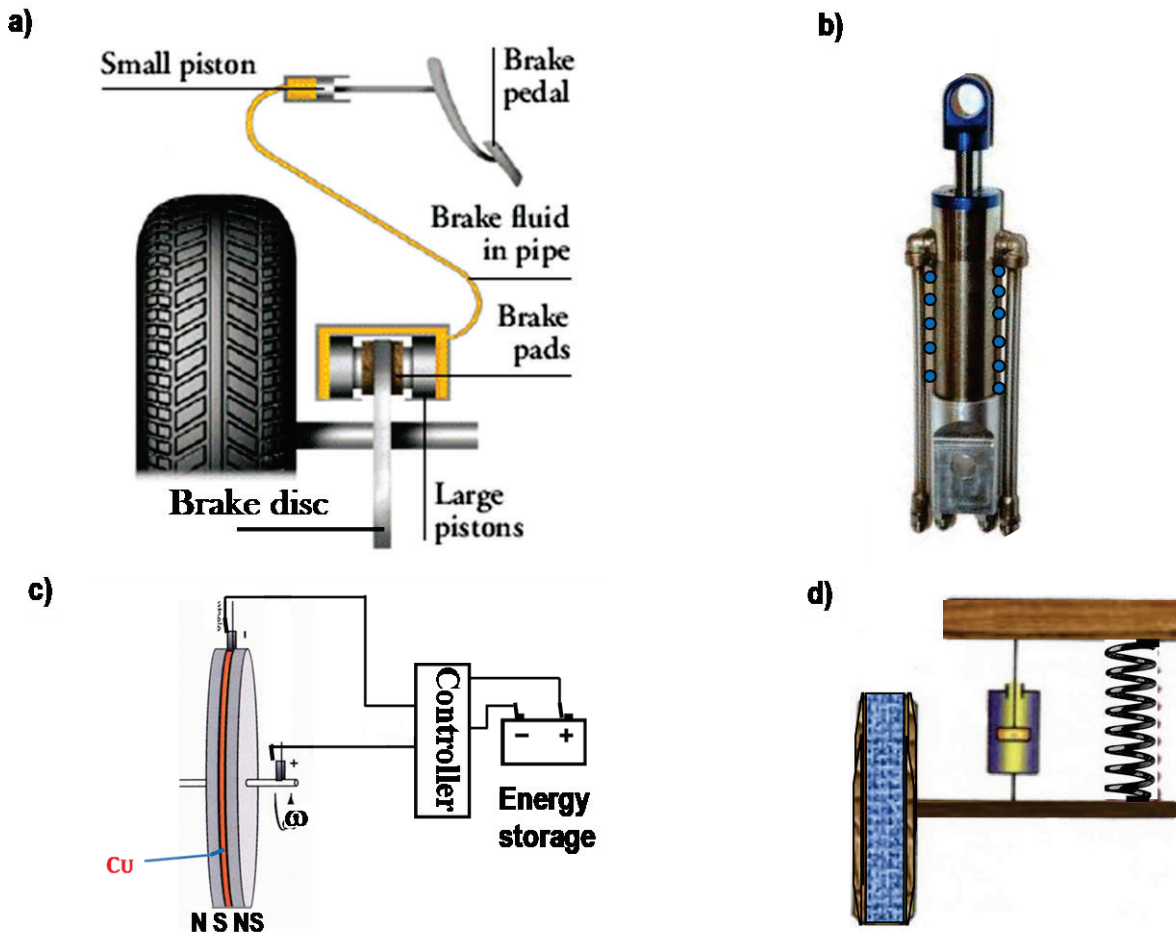

Fig. 3. Energy-harvesting sub-systems: a) car brake with classic disc; b) shock absorber c) modified disc charging an energy storage device; d) shock absorber supplying a supercapacitor

By combining these technologies, concepts and their improvements, it is possible to face towards energy-efficient vehicles, which will greatly simplify our urban transport systems. It is well known that the braking performance strongly influences the safety and riding comfort of vehicles since various phenomena uncontrollable by the driver's pedal operations occur when braking.

In new regenerative braking strategy design, the goal are not only the safety, reliability and easy driving but, above all, the most important factor appears to be the transformation of kinetic energy of the braking car into electric energy. In using regenerative braking, a significant change must be made to the architecture of the vehicle braking system. This can be done in a number of ways and two of which are presented and explained more thoroughly in the following subsection. It has to be emphasized that in this article the focus lies on a system that in some way assists the cars movement.

### 3.2. Modification of the car brake sub-system

Vehicle speed and the driver's brake force command have large impacts on braking efficiency. An effective way to improve the energy efficiency of an electric vehicle is the ability to rebuild the braking system so that the kinetic energy of braking on each wheel of the car can be converted into electricity that must be stored in a battery or/and in a supercapacitor. Full use of the possibilities of this process ensures the application of the disk Faraday generator, whose principle of operation is illustrated in Fig. 4a. It utilizes a strongly compacted device formed by two cylindrical permanent magnets separated by a thin good conductive disk. The disk homopolar generator distinguishes itself from other common generators in that no commutation or alternating of the magnetic poles is necessary for this machine in order to generate electric energy. When the car wheel rotates a voltage between brushes attached to the axle and the rim of the conducting disc is generated and directed appropriately from the driven compact and converts the kinetic energy to electrical energy that can be used for recharging the battery or supercapacitor [5, 8, 9, 13, 19].

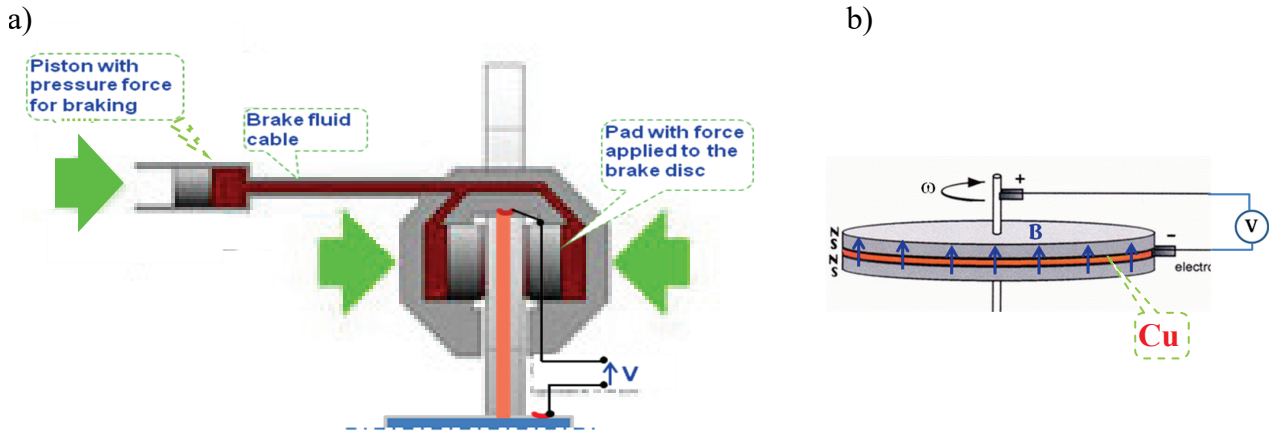

Fig. 4. Modified car brake: a) with Faraday generator; b) model for voltage evaluation

To examine the effect of electromagnetic characteristics on the output of the disk Faraday generator, and to investigate the conditions that result in the maximum efficiency of the generator a comprehensive model that takes into account most of the experimental variables is taken into account and validated by considering limited conditions (Fig. 4b).

The value of the generated voltage can be derived by using Faraday's law of induction and the Lorentz force law, namely:

$$V(t) = \int_r^R \vec{E}_i \cdot d\vec{r} = |\vec{B}| \omega \frac{R^2 - r^2}{2}, \quad (1)$$

where  $\vec{E}_i$ ,  $\vec{r}$  and  $\vec{B}$  denote the vectors of internal electric field intensity, of the radius from the axle and of the magnetic induction, respectively. The rotation velocity is denoted by  $\omega$  and the external and internal radii of the conducting disk are denoted by  $R$  and  $r$ , respectively.

Assuming the radial direction of the current in the conducting disk, the resistance of a disk-shaped conductor can be expressed as:

$$R_t = \rho \int_r^R \frac{dl}{\int_0^{2\pi} h l d\alpha} = \frac{\rho}{2\pi\pi r} \int_r^R \frac{dl}{l} = \frac{\rho}{2h\pi} \ln\left(\frac{R}{r}\right), \quad (2)$$

where  $\rho$  and  $h$  denote the resistivity and thickness of the conducting disk.

The efficiency  $\eta$  of the generator can be defined as the total output energy divided by the input energy, namely

$$\eta = \frac{\int_0^T p(t)dt}{\frac{1}{2}J\omega_0^2}, \quad (3)$$

where  $p(t)$  and  $J$  denote the instantaneous power delivered by the generator to a load and the rotational inertia of the disk, respectively. The time of observation is denoted by  $T$  and  $\omega_0$  is the initial angular velocity of the disk.

In order to determine the power produced as a function of time, we can express  $p(t)$  as

$$p(t) = V(t)I(t), \quad (4)$$

where  $V(t)$  is determined by (1) and  $I(t)$  denotes the current delivered by the generator. The instantaneous values of the current depend on the disk resistance (2) and parameters of dynamic elements representing the load and an intermediate connecting network.

If we assume that a supercapacitor with capacity  $C_s$  represents the load and the connecting network exhibits the structure of an  $R_c, L_c, C_c$  standard two-port network with constant parameters, the complete circuit is described by the following state space equation [17]

$$\begin{aligned} \dot{x} &= Ax + Bu, \\ y &= Cx + Du, \end{aligned} \quad (5)$$

where  $x = [I(t) \ V(t)]'$ ,  $y = V_s(t)$  and  $u = V(t)$  denote the state vector, the output variable and input variable, respectively, with  $V_s(t)$  as the voltage at the load port. Matrices

$$A = \begin{bmatrix} -\frac{R}{L_c} & -\frac{1}{L_c} \\ \frac{1}{C} & 0 \end{bmatrix}, \quad B = \begin{bmatrix} \frac{1}{L_c} \\ 0 \end{bmatrix}, \quad C = [0 \ 1], \quad D = [0], \quad (6)$$

depend on circuit element parameters with  $R = R_t + R_c$  and  $C = C_s + C_c$  as the equivalent resistance and capacitance of the complete circuit, respectively.

The state space equation (5) with (6) can be useful to design a suitable control of regenerative braking of the car. A limitation of this model is that it does not accurately describe a situation when a current with a strong angular component is produced on the disk due to a high angular velocity, or with a high overall current. Thus, the change in the magnetic flux along the path of the electrons creates eddy currents, which consequently resists the rotation of the disk.

To the above two governing equations must be added the description of the physical friction and the armature reaction which represent factors decelerating the rotation of the disk. The frictional torque  $M(t)$  acting on the conducting disk can be modelled through the following equation

$$M(t) = \alpha \cdot \text{sign}(v(t)) + \beta v(t), \quad (7)$$

where  $v(t)$  denotes the car velocity and  $\alpha$  and  $\beta$  are the coefficients of the dry kinetic friction and of the viscous friction, respectively.

The armature reaction commonly referred as a back torque  $H(t)$  that resists the rotation of the generator disk is simply due to the Lorentz force by the induced current and is expressed by

$$H(t) = \int_r^R BI(t)x \cdot dx, \quad (8)$$

where  $x$  denotes a point on the disk.

It has to be noted also that the resulting back torque affects the magnitude of the induced current. Therefore, equations (5-8) constitute the mathematical model of the car braking energy regeneration with the Faraday disk generator, which can be used to, designed and consequently update the parameters and the variables every time the car is run.

It should be underlined that the implementation of this sub-system into electric vehicles should not be much difficult since it seems possible to alter the dimensions of the braking system in order to make it fit in the current control board of passenger cars. It is important to note though that changing the component dimensions might affect imperceptibly the output power of the car. Lastly, the fact that this type of system can replace the braking solutions up-to-date installed in the cars could possibly lower the exploitation cost of the system.

### 3.3. Regenerative damping

Today, the problem of energy becomes so important that all the attention of modern societies is turning towards clean and renewable energies (solar energy, wind energy, etc.) and their efficient consumption. This is why energy regeneration systems of damping in electric cars come also into play [1, 7].

A damper, which is also referred as a shock absorber represents a separate construction device in classic cars for damping excessive vibrations of the sprung and unprung masses by changing the kinetic energy of mechanical vibration movement to heat energy dissipated to the surrounding atmosphere. This means that the damper absorb and dissipate excess energy of dynamic loads. The use of dampers is to achieve smooth movement of the car and eliminating the phenomenon of tearing off the road wheels from the road surface, at maximized comfort and grip. Depending on the damper destination, its structure is always a compromise between driving comfort and grip.

The small amount of energy that is produced when the engine and passengers compartments of a vehicle vibrate while in motion is a possible source for energy harvesting. It is possible to convert vibration/kinetic energy to electric energy by using regenerative shock absorber effectively. The harvested energy from electric car shock absorbers will result in a much more economical vehicle performance and increased comfort of running [12].

Typically, the new linear shock absorber consists of a small magnetic tube with high flux intensity that slides inside a larger, hollow coil tube. Due to bumps and vibrations from normal driving, the sliding tube can produce an electric voltage. When installed in a medium-sized passenger car traveling at 100 km/h, the shock absorber can generate the energy at power of 100-400 watts under normal driving conditions, and up to 1600 watts on particularly rough roads.

The harvested energy is then used to charge the battery and power the vehicle's electronics, which is typically 250-350 watts with optional electronic systems turned off. This energy reduces the load on the vehicle's battery, which usually supplies the DC motor. In this way, the harvested damping energy could increase the battery's efficiency by 1-8%. As a side benefit, the shock absorber also creates a smoother ride due to the ability to adjust the suspension damping and implement self-powered vibration control.

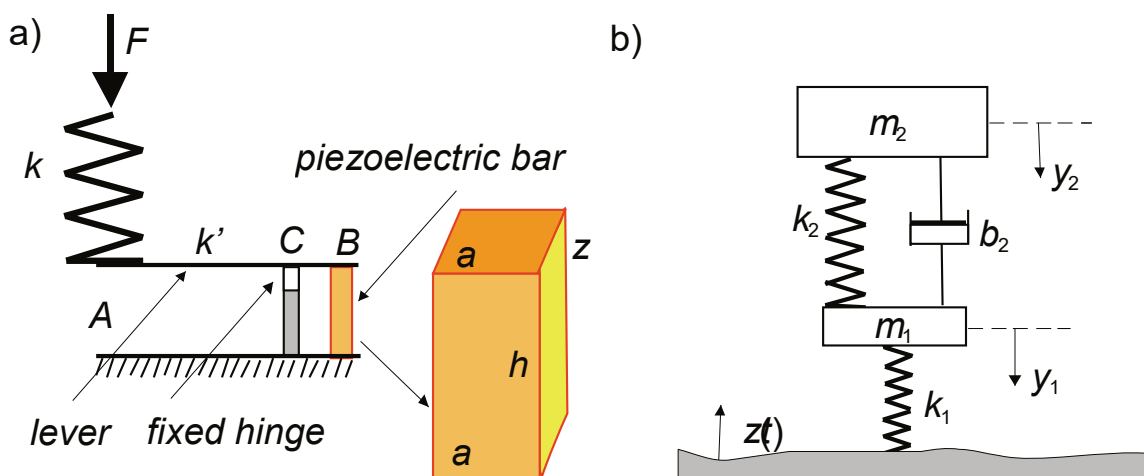

Fig. 5. Model of the dual-mass piezoelectric bar harvester: a) piezoelectric bar transducer b) dual-mass piezoelectric energy harvester

Currently, the mostly available mechanisms suitable for vibrations-to-electric energy conversion are electromagnetic, electrostatic, and piezoelectric transducers. Among these three types of energy transducers, the piezoelectric transducers (Fig. 3d) are preferred because of their efficiency, which is much higher than the two others are. It was yet found out that the energy density of piezoelectric transducer is three times higher than the other two transducers.

To achieve a new effective design with piezoelectric technology of damping energy harvesting for driving vehicles, a dual-mass piezoelectric bar harvester can be developed for absorbing energy from vibrations and motions of a suspension system under excitations of the vehicle from road roughness.

According to the Newton second law of dynamics the governing differential equations of the dual-mass piezoelectric bar harvester system (Fig. 1b) are expressed as follows:

$$\begin{aligned} m_1\ddot{y}_1 + b(\dot{y}_1 - \dot{y}_2) + k_2(y_1 - y_2) + k_1(y_1 - z(t)) &= 0, \\ m_2\ddot{y}_2 + b(\dot{y}_2 - \dot{y}_1) + k_2(y_2 - y_1) &= 0. \end{aligned} \quad (9)$$

where  $k_1$ ,  $k_2$  and  $b$  denote elastance and damping coefficient of the springs and damper, respectively. The displacements of the unsprung mass and sprung mass with respect to their respective equilibrium positions are denoted by  $y_1$  and  $y_2$ , respectively. The form of the road surface in the transverse motion of the car is denoted by  $z(t)$ .

Taking into account the principle that the dissipation energy of a damper is equal to the electric energy generated by the piezoelectric bar harvester, the damping coefficient  $b$  can be expressed as:

$$b = n^2 d^2 k_2^2 / (\pi^2 C f), \quad (10)$$

where  $n$ ,  $d$ ,  $C$  and  $f$  denote the ratio of the moment arms of the lever, the piezoelectric constant in the polling direction; the electrical capacity of the piezoelectric bar and the first natural vibration frequency of the car suspension.

Consequently, we can obtain the instantaneous displacements and velocities  $\dot{y}_1$ ,  $\dot{y}_2$  of the unsprung mass and sprung mass at their respective equilibrium positions. The relative displacements  $y_{12} = y_1 - y_2$  and velocities  $\dot{y}_{12} = \dot{y}_1 - \dot{y}_2$ , of the unsprung mass and the sprung mass can also be determined. Then the generated charge  $q(t)$ , and voltage,  $V(t)$ , from the piezoelectric bar at time  $t$  can be expressed by relations:

$$\begin{aligned} q(t) &= ndk_2 y_{21}(t), \\ V(t) &= q(t) / C, \\ I(t) &= ndk_2 \dot{y}_{21}(t). \end{aligned} \quad (11)$$

Thus, the instantaneous power  $p(t)$  and energy  $E(t)$  generated from 0 to  $t$  by the piezoelectric bar can be evaluated as:

$$\begin{aligned} p(t) &= (ndk_2)^2 y_{21} \dot{y}_{21}, \\ E(t) &= \frac{(ndk_2)^2}{C} \int_0^t y_{21} \dot{y}_{21} d\tau. \end{aligned} \quad (12)$$

It is easily seen that the energy  $E(t)$  increases with an increase in the velocity of vehicles and the class of road surface, an increase in the ratio of the moment arms of the lever, and with a decrease in the width of the piezoelectric bar. It can be expected that in practice four or more of the novel piezoelectric bar energy harvesters could be installed on a vehicle and provide more efficient energy harvesting as an auxiliary energy of electric cars. This offers the energy regeneration as much as possible from the damping kinetics and stores it to be used for a useful purpose such as an auxiliary on-board electric energy source.



#### 4. Supercapacitor characterization

The supercapacitor also known as ultra capacitor is a high power density energy storage device that can deliver high short-term discharging current and acquire burst of charging current. It can effectively absorb the regenerative energy during braking and provide extra-current for hill climbing. It should be emphasized that the supercapacitor does not have the drawbacks of electrochemical batteries like poor temperature coefficient, limited charging and discharging cycle, and critical charging current. It can be used in tandem with batteries for performance improvement of electric cars [1, 16].

In general, the supercapacitors have higher power densities than batteries, as well as sub-second response times. The capability of the present material technology to synthesize nanostructured electrodes with tailored, high-surface-area architectures offers the potential for storing multiple charges at a single site, increasing charge density. The addition of surface functionalities could also contribute to high and reproducible charge storage capabilities, as well as rapid charge-discharge functions. The design and manufacturing of new materials with tailored architectures optimized for effective capacitive charge storage will be catalysed by new computational and analytical tools that can provide the needed foundation for the rational design of these multifunctional materials. These developments also provide the molecular-level insights required to establish the physical and chemical criteria for attaining higher voltages, higher ionic conductivity, and wide electrochemical and thermal stability in electrolytes. Electrical energy is stored in the electric field between its plates and as a result of this stored energy; a voltage exists between the two plates. A charged ultra-capacitor can store this electrical energy even when removed from the voltage supply until it is needed acting as an energy storage device. The amount of energy stored is proportional to the capacitance  $C$  and the square of the voltage  $V$  across its terminals.

A supercapacitor can accept a wide of charging current so that precise current control is not necessary. The criterion for terminating charging is the maximum rated voltage of a supercapacitor. It is under repetitive charging with a quit short time constant and can be completely discharged within a few minutes or even just a couple of seconds, and then fully charged again within a short period.

a)



b)



Fig. 6. Supercapacitors: a) view of fabricated product; b) equivalent circuit of a supercapacitor

The capacities of the supercapacitors coming up to 2700 F (Fig. 6a), combined with the short charging/discharging cycle time, are achievable at very high power density (unit power), up to 10 kW/kg, which exceeds the unit power of modern batteries. Supercapacitors are suitable for use in systems where low energy is transferred at high values of the power. They operate typically well in impulse state conditions. The permissible operating voltage is in the range 2-3 V. If a switching mode DC-DC converter with pulse width modulation (PWM) is in use as a charger then it operates in such a way that provides a maximum charging current for a short period and then reduces to zero until next charging cycle.

The second-order circuit model of a supercapacitor is shown in figure 6b. It consists of a series resistance and an inductance, and the leakage current is represented by a resistor in parallel with the capacitor. The series resistance ranges from a few milliohms to several tens milliohms. The inductance depends on the construction, and it can be ignored for low frequency operation. The leakage resistance can also be ignored for short-term operation. Actually, the leakage current of a supercapacitor with capacitance over 500 farads is less than 10 mA and its rated current is over a hundred of amperes.

## 5. Simulations

The present expansion of transportation, mostly in large towns, induces serious problems resulting from inability of municipal authorities to cope with situations on crowded roads and crossroads. There are more requirements put on modern vehicles, namely to achieve high accelerations during start-ups at crossroads and, last but not least, during overtaking which is closely related with not only the safety of car passengers but also of pedestrians near the streets. One objective is to evaluate – on the basis of numeric simulations – an effective influence of the energy harvesting during car braking and converting via particular devices the kinetic energy of the car suspension into electric energy.

Two homologation tests were selected for the city traffic simulation: UDC (Urban Driving Cycle) has shown in Figure 7 and the Stop and Go special test to simulate driving in traffic congestion, which is presented in Fig. 8. Observe, that this test is characterized by frequent acceleration and braking, and the vehicle's average speed is 5.8 km/h. Moreover, the test Stop and Go is characterized by stronger dynamic properties than the UDC test.

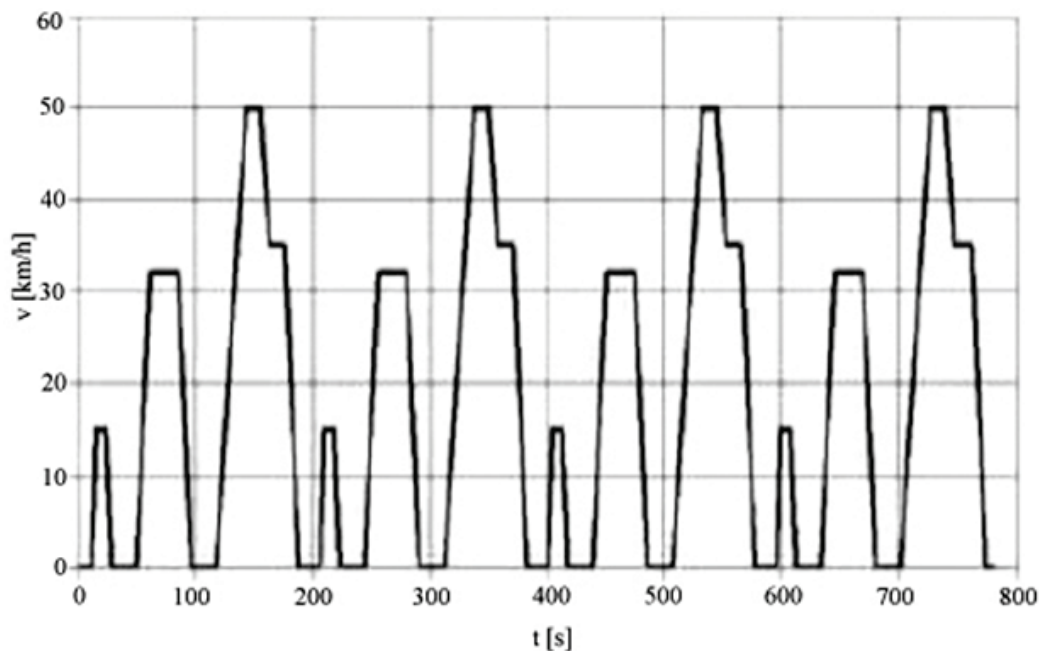

Fig. 7. Time-varying car velocity according to UDC test

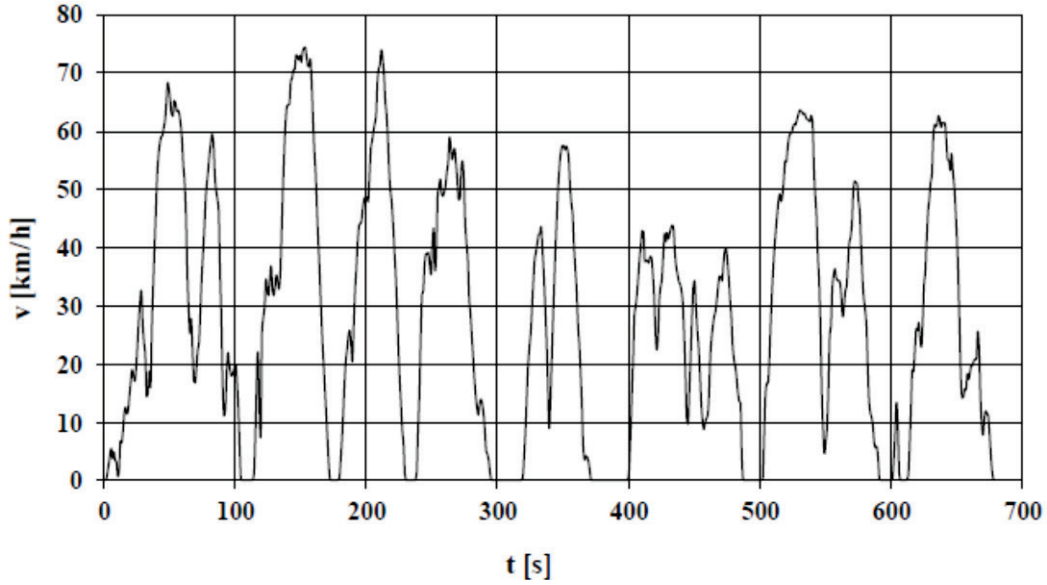

Fig. 8. Time-varying car velocity according to Stop and Go test

To enhance the efficiency of the energy harvesters their mathematical and computational models have been developed and experienced. It has to be emphasized that the theory, modelling, and simulation can effectively complement experimental efforts and can provide insight into mechanisms, predict trends, identify new materials, and guide experiments.

For a given Faraday generator installed in the car wheel's disc brake, the relationship between the speed and the generated voltage can be derived applying the relation (1) and the relationship between the circular and linear speeds  $v(t) = r_w \omega(t)$  with  $r_w$  as radius of a wheel tire. Thus, we have

$$V(t) = \int_r^R \vec{E}_i \cdot d\vec{r} \cong |\vec{B}| \frac{R^2 - r^2}{2r_w} v(t). \quad (13)$$

Since in practice  $r \ll R$ , then with a good precision we can convert expression (13) to the following form

$$V(t) \cong |\vec{B}| \frac{R^2}{2r_w} v(t) = Av(t), \quad (14)$$

where the structural constant  $A$  is defined by the expression

$$A \cong |\vec{B}| \frac{R^2}{2r_w}, \quad (15)$$

Taking  $|\vec{B}| = 1.6\text{T}$ ,  $R = 15\text{ cm}$  and  $r_w = 1.25R$  yields  $A = 0.096\text{ Vs/m}$ .

The full potential of supercapacitors as electric energy storage devices was checked out by using the model system representing a supercapacitor charged with the aid of a Faraday generator attached to a car wheel. The circuit mapping the process of the supercapacitor charging is shown Fig. 9, which consists of only five major components. Energy operates at fixed frequency and duty cycle with  $V_{in}$  as voltage generated by braking. Although the circuit does not consist of any current transducer or closed loop control circuit, the input current is limited because the peak current of the inductor is limited by a fixed turn-on time.

When the synchronous switches,  $S1$  and  $S2$ , are turned on, the inductor current can be expressed by:

$$V_{in} = L di_{on} / dt + R_L i_{on} + 2V_S, \quad (16)$$

where  $V_S$  is the voltage drop across a synchronous switch. The values of  $V_S$  and  $R_L$  are small, and the voltage drops are negligible in this stage.

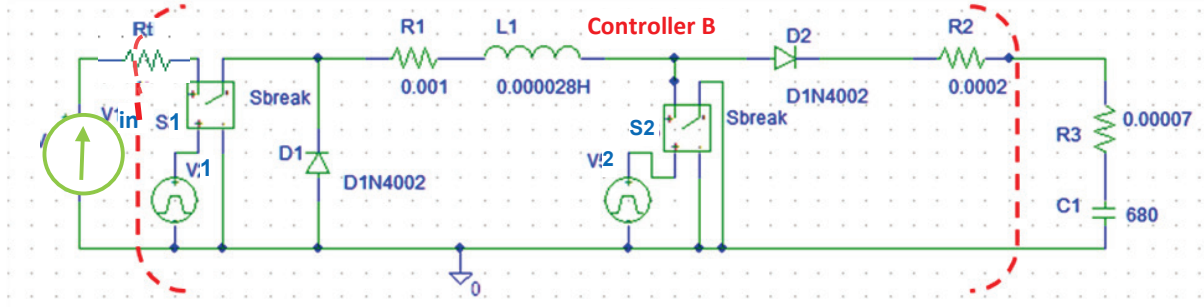

Fig. 9. Charging the supercapacitor 680 F

When the synchronous switches,  $S1$  and  $S2$ , are turned on, the inductor current can be expressed by:

$$V_{in} = L \frac{di_{on}}{dt} + R_L i_{on} + 2V_S. \quad (17)$$

where  $V_S$  is the voltage drop across a synchronous switch. The values of  $V_S$  and  $R_L$  are small, and the voltage drops are negligible in this stage. Then

$$V_{in} = L \frac{di_{on}}{dt}. \quad (18)$$

If the turn-on time is short, (18) can be approximated by a linear equation. Thus, the peak inductor current during  $T_{on}$  is given by

$$I_{peak} = V_{in} T_{on} / L. \quad (19)$$

During the energy transfer state, the synchronous switches  $S1$  and  $S2$ , are turned off. The inductor current can be expressed by:

$$L \frac{di_{off}}{dt} + (R_L + R_w + R_C) i_{off} + \frac{1}{C} \int_0^t i_{off} dt + V_{C0} = -2V_d, \quad (20)$$

where  $V_{C0}$  is the previous voltage of the supercapacitor, and  $V_d$  is the voltage drop of each diode. As an extreme condition,  $V_{C0}$  is zero when the supercapacitor is completely discharged.

The inductor current of this stage can be expressed as:

$$i_{off}(t) = \left( I_{peak} - \frac{2V_d + V_{C0}}{L} \right) \left( \frac{ae^{at} - be^{bt}}{a-b} \right), \quad (21)$$

where

$$a = -\frac{R}{2L} - \frac{1}{2} \sqrt{\left(\frac{R}{L}\right)^2 - \frac{4}{LC}}, \quad b = -\frac{R}{2L} + \frac{1}{2} \sqrt{\left(\frac{R}{L}\right)^2 - \frac{4}{LC}},$$

denote the roots of the characteristic equation of (16) with  $R = R_L + R_w + R_C$ .

When there is no initial charge stored in the supercapacitor, then  $V_{C0}$  is zero. To ensure the circuit operation at boundary condition, the inductor current  $i_{off}$  should reduce to zero at the end of energy transference stage. Substituting  $V_{C0} = 0$  and (14) into (17), we have

$$V_{in} T_{on} (ae^{at} - be^{bt}) = 2V_d (e^{at} - e^{bt}), \quad (22)$$

Solving (18) with respect to  $T_{on}$  yields

$$T_{on} = \frac{2V_d (e^{at} - e^{bt})}{V_{in} (ae^{at} - be^{bt})}. \quad (23)$$

There are two states of operation per switching cycle, namely energy absorption and energy transference states, respectively. During the first state, the inductor absorbs energy from the supplying source. Then, it delivers the energy to the supercapacitor at the second state and the supercapacitor can acquire constant amount of energy per switching cycle.

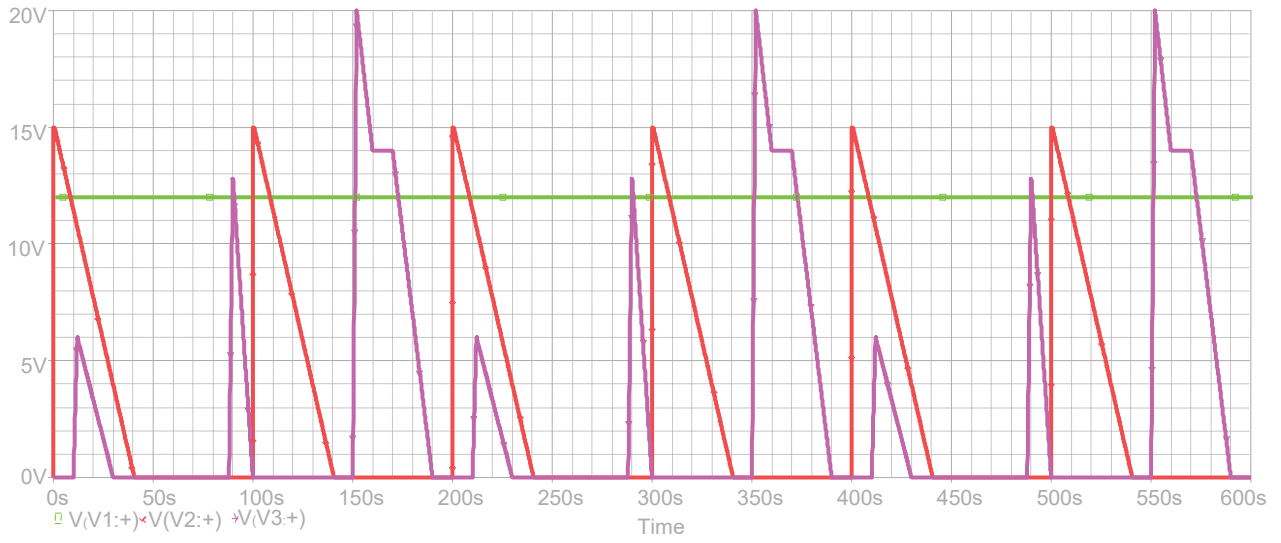

Fig. 10. Generated voltages taken as  $V_{in}$  into simulations

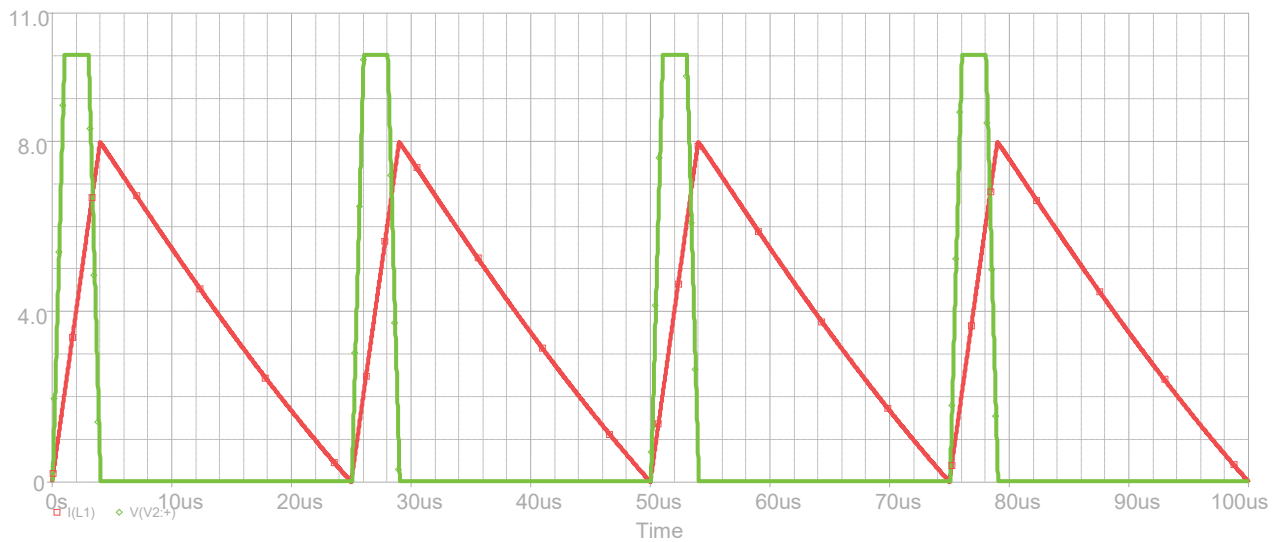

Fig. 11. Current in the coil and switching voltage for charging the supercapacitor at  $V_{in} = V_1$

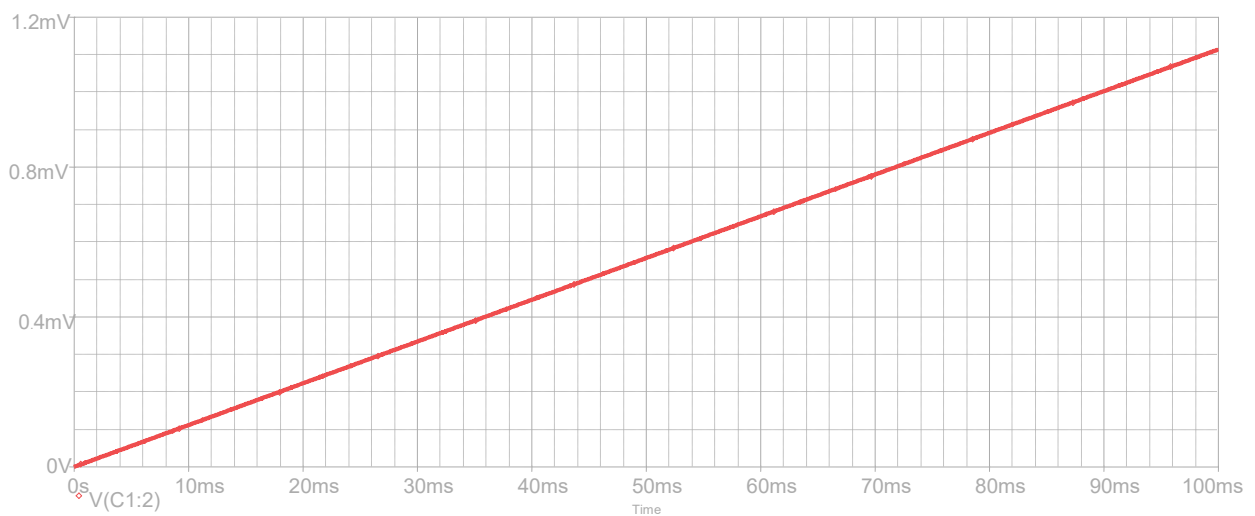

Fig. 12. Supercapacitor voltage vs. time when  $V_{in} = V_1$

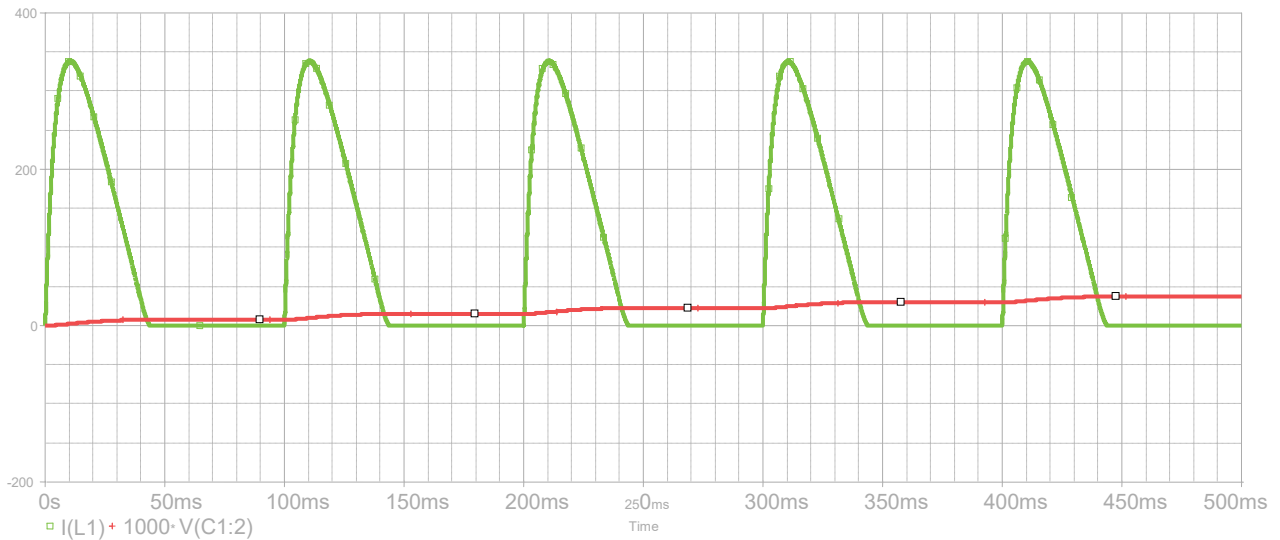

Fig. 13. Current in the coil and supercapacitor voltage vs. time when  $V_{in} = V_2$

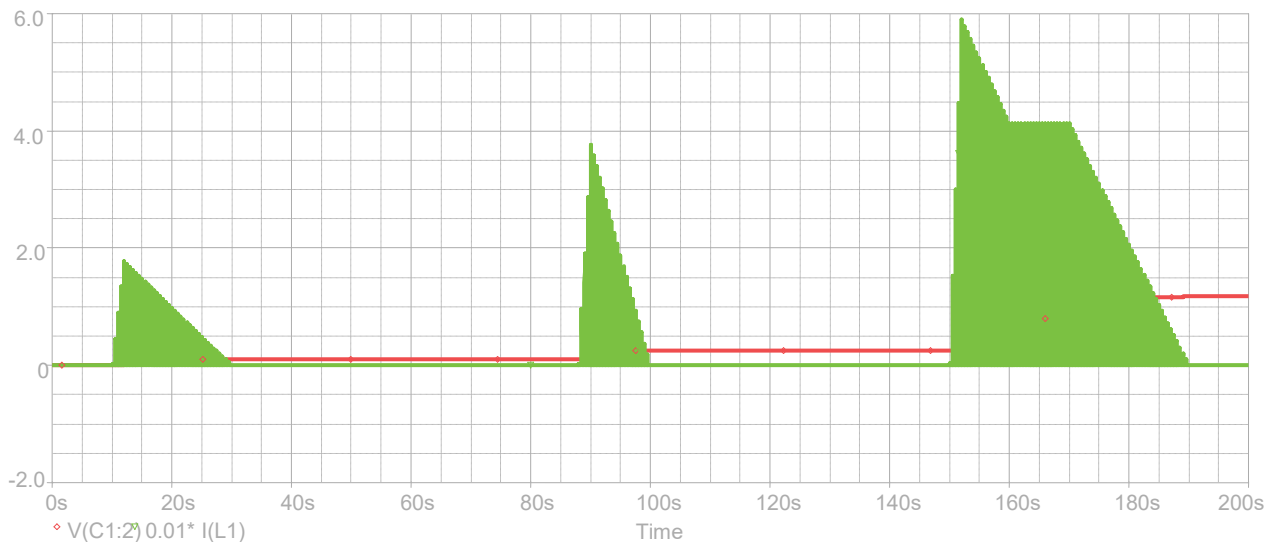

Fig. 14. Current in the coil and supercapacitor voltage vs. time when  $V_{in} = V_3$

By testing the appropriate cases of city driving, we cannot only change the voltage  $V_{in}$  generated at the input in the model circuit, but also control the driver's switches and thus obtain information on the optimal parameters of the practical system. Taking the wire resistance  $R_W$  less than  $0.5 \Omega$ , it is possible to minimize the conduction loss. The turn-off time and switching frequency is determined by the ratio of the inductance  $L$  and total series resistances of  $R_L$ ,  $R_W$  and  $R_C$ . However, the total resistance of  $R_L$  and  $R_W$  can be taken as greater the equivalent series resistance of the supercapacitor and the influences of different characteristics of the supercapacitors provided by various manufacturers are negligible.

Numerical experiments with regard to vehicle braking indicate that the highest voltage on the supercapacitor is generated at both high speed and deceleration time. This is evident in the Stop and Go test when the supercapacitor is charged fastest and at the higher voltage (Fig. 14) when comparing to the remaining test cases (Figs. 12 and 13). The obtained result is very significant when we take into consideration that it has been achieved only due to a better controlling of the regenerative energy by means of an appropriately chosen switching frequency and values of the coil inductance, without any change of the unipolar disk generator dimensions or maximum value of ride velocities.

## 6. Summary and conclusions

To realize the full potential of the Faraday disk generator in connection with supercapacitors as electrical energy recovering and storage devices, new materials and chemical processes can improve the efficiency of energy harvesting in electric cars by increasing both the recovered energy and its storage densities. The performance of energy storage systems is limited by the efficiency of the constituent materials—including active materials, conductors, and inert additives. Advances in nanoscience and nanotechnology offer particularly exciting possibilities for the development of revolutionary three-dimensional architectures that simultaneously optimize components and energy harvesting capacities. Theory, modelling, and simulation can effectively help experimental design and efforts and can provide better insight into mechanisms, predict trends, identify new materials, and guide experiments. The discovery of such new nanostructured materials as graphene and carbon nanotubes has opened opportunities to develop novel tailored system components [18, 22].

Electric cars, even if powered by electricity generated by coal-powered plants are much more efficient than combustion engine based vehicles and as a result release less CO<sub>2</sub> emissions and are noiselessly. Between the main benefits, resulting from the spread of electric vehicles in cities is a „shift“ of harmful air pollutants from municipal areas to rural regions where the exposure of the living organisms to the detriment of biological state is lower. It is worth underline, especially in urban driving conditions, that the noise level generated by electric vehicles is so low that it often can even pose a danger to pedestrians in the streets.

The supercapacitors play important roles in the development of electric vehicle industry. A new charging circuit with minimal number of components count has been presented. It provides high reducing in the production cost as well as circuit failure rate. Applying the developed equations, optimal inductance and switching frequency of the PWM controller can be determined. The charger can fully charges up a 680 F supercapacitor over a dozen minutes. The circuit does not consist of complicated closed loop control and is free of stability problem. It favours the application of supercapacitor-battery combination system for electric cars.

## References

- [1] Briand, D., Yeatman E., Roundy, S. (eds.), *Micro Energy Harvesting*, Wiley-VCH, Weinheim, 2015.
- [2] Chan, M. S. W., Chau, K. T., Chan, C. C., *Effective Charging Method for Ultracapacitors*, Journal of Asian Electric Vehicle, Vol. 3, No. 2, pp. 771-776, 2005.
- [3] Cottone, F., *Introduction to Vibration Energy Harvesting*, NiPS Energy Harvesting Summer School, August 1-5, 2011.
- [4] Eberhard, M., Tarpenning, M., *The 21st century electric car*. Tesla Motors Inc. 6 October 2006.
- [5] Engel, T. G., Kontras, E. A., *Analysis and design of homopolar motors and generators*, 17th International Symposium on Electromagnetic Launch Technology (EML), IEEE, La Jolla, CA, USA, 7-11 July, 2014.
- [6] van Essen, H., Kampman, B., *Impacts of electric vehicles – Summary report*. Publication number: 11.4058.26. www.cedelft.eu, Delft, April 2011.
- [7] Demetgul, M., Guney, I., *Design of the Hybrid Regenerative Shock Absorber and Energy Harvesting from Linear Movemen*, Journal of Clean Energy Technologies, Vol. 5, No. 1, pp. 81-84, 2017.
- [8] *Faraday Generator*, eskola.hfd.hr/icm/.../14.%20%20Faraday%20Generator.pdf.
- [9] *High Current Compact Generator*, magniX Technologies Pty Ltd., Arundel, QLD 4214, Australia, 2016, www.magniflux.com, 2016.
- [10] Kim, J., Cottone, K. F., et al., *Energy scavenging for energy efficiency in networks and applications*, Bell Labs Technical Journal, Vol. 15, No. 2, pp. 7-29, 2010.

- [11] Matak, M., Šolek, P., *Harvesting the Vibration Energy*. American Journal of Mechanical Engineering, Vol. 1, No. 7, pp. 438-442, 2013; doi: 10.12691/ajme-1-7-57, 2013.
- [12] Mazurkiewicz, A. (ed.), *Nanosciences and nanotechnologies. Present state and development perspectives*. Institute of Exploitation Technology – State Research Institute, Radom, 2007.
- [13] Nezhad, M. B., *Study of Homopolar DC Generator*, Ph.D. Thesis, The University of Manchester, Manchester, 2012, <https://www.escholar.manchester.ac.uk/uk-ac-man-scw:19941>, 2012.
- [14] Park, G., *Overview of Energy Harvesting Systems*, Los Alamos National Laboratory, [www.sciencedirect.com/science/article/pii/S092702480870519](http://www.sciencedirect.com/science/article/pii/S092702480870519).
- [15] Priya, S., Inam, D. (eds.), *Energy Harvesting Technologies*. Springer, Berlin, 2008.
- [16] Stevic Z., Radovanovic I., *Energy Efficiency of Electric Vehicles*, in Stevic Z. (ed.): *New Generation of Electric Vehicles*, In Tech, Rijeka, 2012.
- [17] Trzaska, Z., *Impact and chaotic phenomena in nonlinear nonsmooth electrical dynamical systems*. KONES, Vol. 91, No. 3, pp. 77-85, 2015.
- [18] Trzaska, M., Trzaska, Z., *Nanomaterials Produced by Electrocrystallization Method*. in: Aliofkhaeai, M., Makhlouf, A. S. H. (eds.), *Handbook of Nanoelectrochemistry*, Springer, Basel, 2015.
- [19] Trzaska, Z., *Experiments with disk Faraday Generator*, Proceedings of the Conference Progress in Applied Electrotechnics, Kościelisko, Poland, 23-27 June, pp. 251-260, 2003.
- [20] Trzaska Z., *Dynamic processes in the electric drive system in the urban traffic*, Transport miejski i regionalny, No. 11, pp. 26-31, 2013.
- [21] *Wheel to Well Analysis of EVs*. MIT Electric Vehicle Team. MIT. April 2008. [http://web.mit.edu/evt/summary\\_wtw.pdf](http://web.mit.edu/evt/summary_wtw.pdf), 2008.
- [22] Wolf, E. L., *Nanophysik und Nanotechnologie*. Wiley-VCH, Weinheim, 2015.

*Manuscript received 19 September 2017; approved for printing 25 January 2018*