

ANALYSIS FORMING THE DIAMETER REDUCTION OF THE TUBE TO THE CYLINDER HYDRAULIC SHOCK ABSORBER

Andrzej Świątoniowski, Janusz Szostak, Krzysztof Gomulka

AGH-University of Science and Technology
Adama Mickiewicza Av. 30, 30-962 Cracow, Poland
tel.: +48 12 6173107, fax: +48 12 6173133

e-mail: swiatoni@imir.agh.edu.pl, szostak@agh.edu.pl, gregorczi@imir.agh.edu.pl

Abstract

The article presents the process of reducing the pipe and the influence of the shape of the tool on the geometric parameters of the cylinder. Charge material tube is precision welded cold drawn with an outer diameter \varnothing 57 mm, made of stainless E355. Reduced pipe is used for cylinder hydraulic shock absorber. Formed cylinder is part of the structure MacPherson strut front suspension vehicle. Tube reduction process is carried out with cold working by using a hydraulic press. Analysed the influence of the diameter of the tool \varnothing and profile angle α transition into basic the geometric parameters of the deformed cylinder: inner diameter, wall thickness, pipe cylindrical deviation effect. The result of numerical simulation is a map of HMM stress. As well as the effect of the transition profile, angle the value of the tool diameter of the inner pipe, wall thickness and the value of cylindrical deviation effect. In this paper a comparative analysis of the outer diameter, inside diameter and cylindrical deviation effect for physical and numerical studies. Simulation of reduce tubes was carried out with DEFORM 3D software based on the finite element method. Numerical analysis allowed for a detailed knowledge of the specifics of the process and a comprehensive analysis of phenomena that are not possible to explore traditional methods.

Keywords: reducing tube, MESS, cylinder hydraulic shock absorber, DEFORM 3D

1. Introduction

The front suspensions of cars are widely used today, the so-called MacPherson struts, coil springs in which the work of the two tubular shocks oil. In this system, a shock absorber not only acts as a damper, but also the guide element, which places its structure additional requirements and limitations. This is particularly the formation of the outer cylinder shock absorber, whose throat (change diameter) to allow welding bracket (plate) spring suspension, and give the bottom of the form to ensure proper mounting of a crossover vehicle.

It is necessary to also adjust the internal diameter of the cylinder to the piston rod guide and gasket, which are part of the guide sealing assembly. In view of the extremely tough competition prevailing among vehicle manufacturers, reducing production costs while providing its high quality has now become an essential condition for market presence. Hence, the general objective is a widest possible use in the production of vehicles forming technology while limiting expensive machining technology [1, 4].

2. Modelling of process reduction of suspension hydraulic cylinder

The analysis is the impact of the shape of the tool (Fig. 1b) in the process of changing the diameter of the pipe constituting the blank to complete cylinder hydraulic shock absorber. The process is performed by reduction with the use hydraulic press [2]. Plastic deformation of the material, which changes the diameter of the pipe, occurs a result of its passage through the die ("eye") with a cone shaped working surface (Fig. 1).

In this process - in contrast to the more widespread drawing process load in the form of axial force is applied at the input to the tool and runs on unreformed section blank.

Such a scheme load determines both the same process and the quality of the product in it.

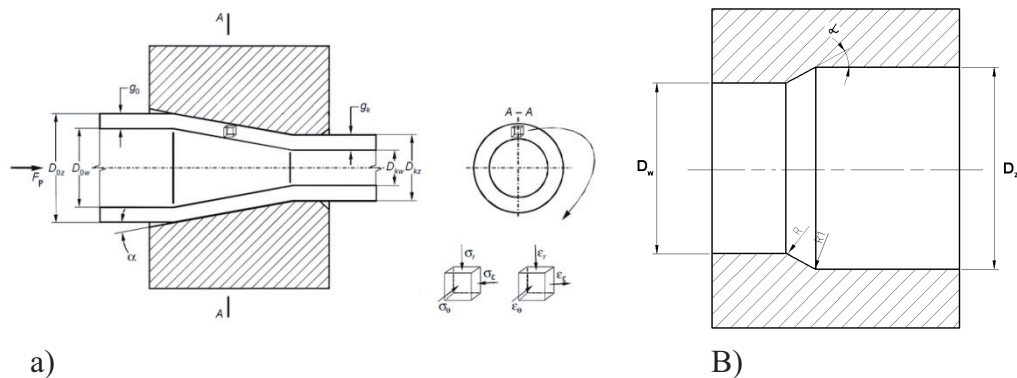

Fig. 1. Diagram of a process of reduction a) and a cross-section through the eye of the die b)

Mathematical model of the process were based on the Finite Element Method using software DEFORM 3D.

The calculations were made assuming the following boundary conditions:

- workpiece material was defined as an object “elasto-plastic” anisotropic structure and properties described flow curve removed during uniaxial tensile tests [5] taken from the blank in the form E355 precision steel tubing welded cold drawn. DIN EN10305-2,
- moulding tools and pusher modelled as objects of type "rigid" (non deformable). This is consistent with common practice description tools plastic working processes [3] in particular - when, as it is the present case – subject of analysis is itself metal flow without the prevailing stress state in the tool,
- the contact conditions between the tool and the forming metal described assuming model “shear”, according to which the value of the stresses derived from the friction is dependent on the value of the yield stress of the material for pure shear,
- the workpiece there is axisymmetric state of stress,
- forming process is carried out at a temperature of 18°C,
- changes in strain rate are so small that they do not affect the characteristics of the material.

3. Effect of shape tool geometric dimensions shock absorber cylinder after process change the diameter

The correctness of the calculation and simulation obtained on the basis of a mathematical model of the process was verified by comparing the shape and dimensions (Tab. 1) cylinder after the operation.

On this basis, it was found that the work presented in the FEM model provides a faithful representation of the process of reducing the diameter of the cylinder, and thus may facilitate the analysis of the impact of the shape of the tools on this process and the quality of the product in it.

Tab. 1. Comparison of the geometry of ends of the cylinder

	The outer diameter D_o [mm]	Max ext. diameter after process with cylindrical deviation D_k [mm]	The internal diameter D_i [mm]
The process of actual	51.40	52.14	45.80
The process simulant	51.34	52.24	45.66
The absolute error	0.16	0.10	0.14

The results of the simulation during the operation are shown graphically in the figures. Analysed the influence of the diameter of the tool \varnothing and profile angle α transition into four basic – determine the quality – the geometric parameters of the deformed cylinder: inner diameter, wall thickness and outer diameter with cylindrical deviation effect.

The thus obtained results can be used for selecting the value of the angle α and the diameter D_0 required obtaining the final diameter of the cylinder.

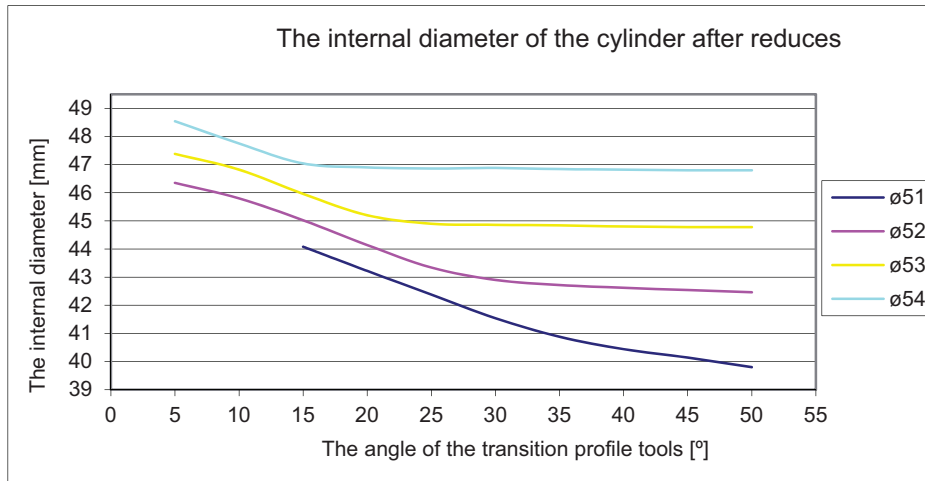

Fig. 2. Effect of the transition profile angle α of tool the value of diameter of the inner cylinder at the end of the process

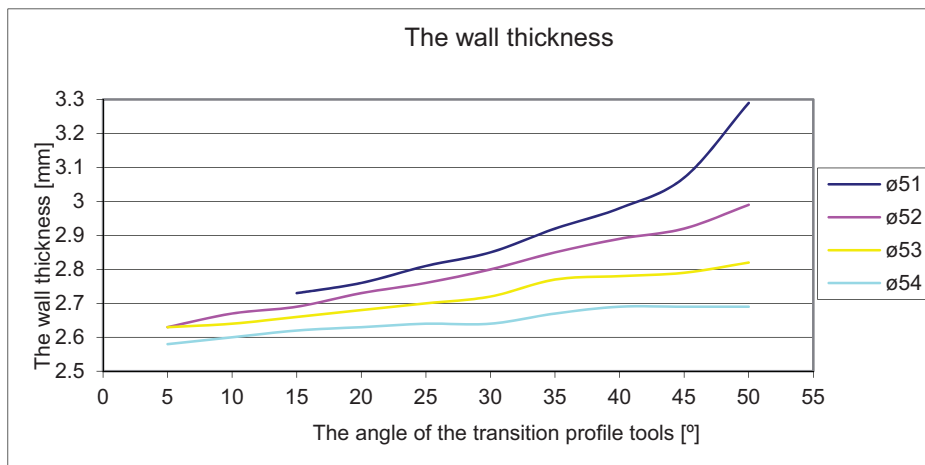

Fig. 3. Effect of the transition profile angle α to the wall thickness of the cylinder after the process

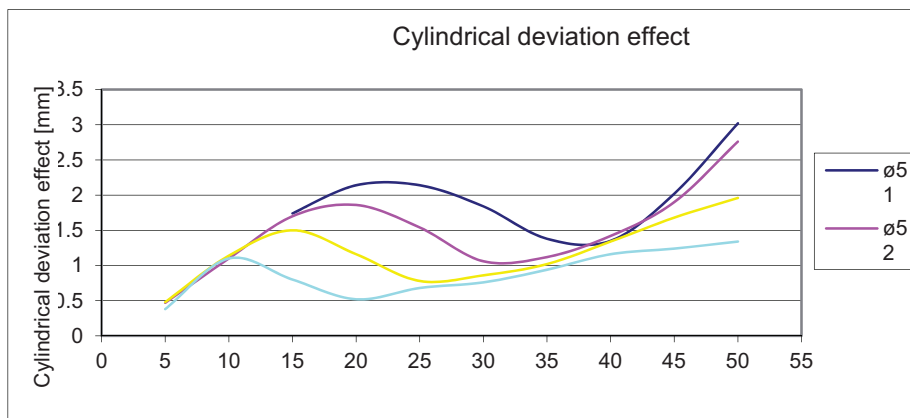

Fig. 4. Effect of the transition profile angle α cylindrical deviation effect value after the process the cylinder

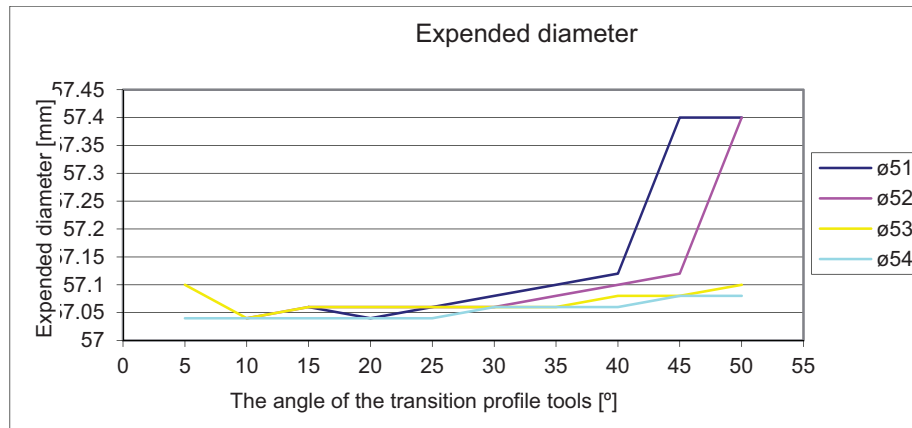

Fig. 5. Effect of the transition profile angle α expanded value after the process the cylinder

Based on the results of the analysis may be ordered as follows:

Application tool with a smaller diameter output and higher values of the angle α profile transition leads to an increased inner diameter of the cylinder (Fig. 2) and the thickness of the wall (Fig. 3) after completion of the process. The value of the expansions to bear on inner diameter tolerances achieved varies non-linearly with the values of the angle α of transition profile reaching a local minimum at a value equal to the angle of 5 degrees. The observed differences between the minimum and maximum diameter of the cylinder after the reducing amount to 3 mm, which determines the need for further processing (expandable cutting ends or calibration cylinder from the inside) to achieve the desired shape and dimension tolerances.

A plot of the diameter of the cylinder before reducing zone from the profile angle α indicates a significant increase in the diameter selected for large deformations (small end diameter to the tool). For angles α above 40 degrees in the case $D_i = 51$ mm and $D_i = 52$ mm increase in diameter of the cylinder was big enough, that there has been contact between the leading tools that for the test cylinder with an outer diameter of the initial $\varnothing 57$ had a diameter of 57.4.

4. Effect of shape tool for stress state of shock absorber cylinder after process of the change diameter

During the process of material moulded shock absorber cylinder is subjected to a compound state of stress (Fig. 6). The highest values among them acquire a hoop stress σ_θ , which in the contact zone of the material and tools reach the level of 2000 MPa. There are compressive stresses. The same character is found in this zone radial stress σ_r . The value of the stress varies along the wall to adopt the maximum value of $\sigma_r = p_n$ tube on the contact surface of the tool and the minimum value on the opposite surface of the cylinder.

As the distance from the axis of the nature of these stress changes (in the direction of increase in compression or tensile transition), and that as a result of the impact of bending to which the reducing cylinder.

Before entering the zone of the forming tool are subjected to a uniaxial compression, and the value of the stress is the ratio the reducing force to the field of initial surface of the cylinder.

Analogously as was the case with deformable geometric dimensions of the cylinder, also the state of stress in the wall depends on the shape of the tool Fig. 7.

It can be seen that the value of the reduced maximum stress increases with increasing angle of the transition profile of the tool. It may be noted that for angles greater than 30° in each of the examined cases exceeded 907 MPa of stress, i.e. the value corresponding to break the sample during the static tensile test. For tools with a larger diameter end ($\varnothing 53$ and $\varnothing 54$), the boundary condition occurs earlier due to the so-called. Haul material, which causes an increase in reduced stresses at the outer surface of the deforming cylinder. These are caused by taking out a small

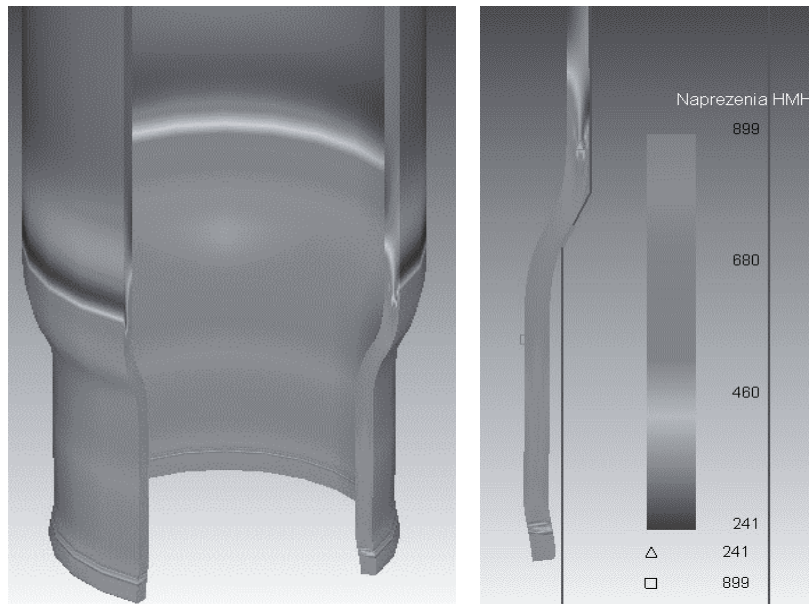

Fig. 6. Distribution of HMM reduced stresses in the cylinder wall during the process

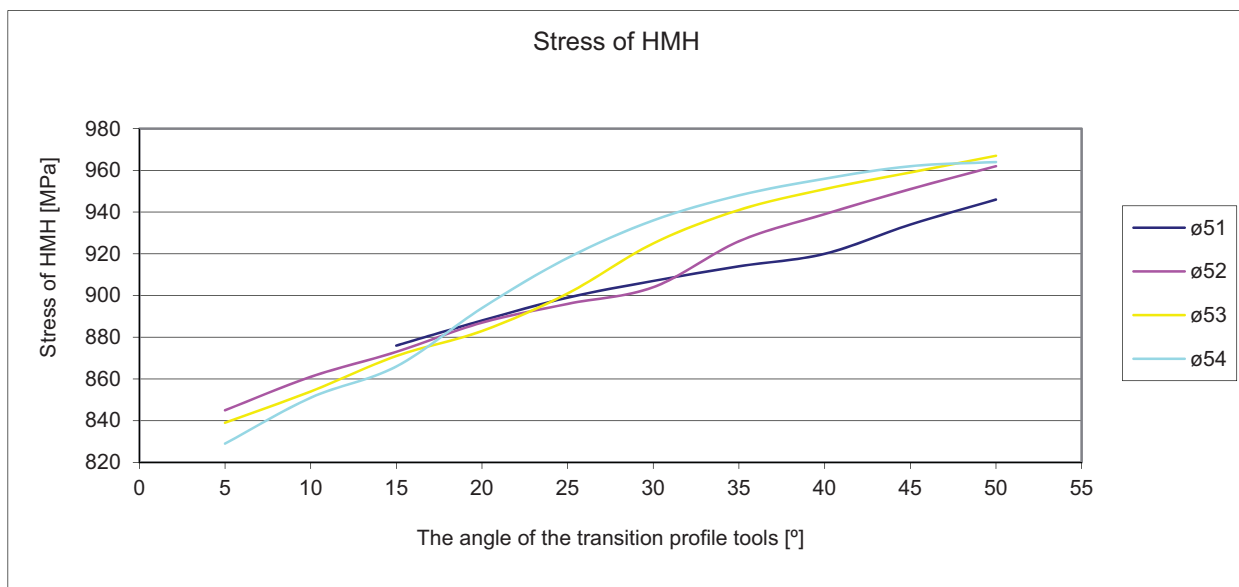

Fig. 7. Effect of tool profile transition angle α to a value HMM reduced stress in the cylinder wall during the process

contact surface of the tool with the metal, which occurs when small changes in diameter. Said contact surface decreases with increasing angle of crossing profile, and thus the risk of large angles of haul is greater.

4. Conclusion

1. Based on a comparison of experimental results with predicted numerically found good agreement between the model and the actual course of the process, both in terms of the geometry of the product, and the value of reducing force.
2. It was found that during the reducing process would always reach the wall thickening of the product, which is associated with the prevailing state of stress; the size of the increase of the wall is dependent on the shape of the tool.
3. It was observed, that is too small contact surface material of the tool may be called "haul" material, which can lead to cracks or loss of functionality of the product.

4. On the basis of the simulation results is proposed in some cases change conical tool on arc shaped tool to ensure greater accuracy of the geometric product.
5. Creating a faithful numerical model allowed for a more detailed knowledge of the specifics of the process and a comprehensive analysis of phenomena, which, due to its complexity, it is difficult to examine using traditional methods.

Acquired in this way knowledge is invaluable when designing tool, suggests that course to take in the quest for continuous process improvement. The possibility of virtual verification process parameters before its implementation enables reduction of costs needed for testing and design change tooling, improved design tool for production time and material costs, and shorter time to market of new products.

References

- [1] Sińczak, J., *Podstawy procesów przeróbki plastycznej*, Wydawnictwo Naukowe AKAPIT, Kraków 2010.
- [2] Ziółkiewicz, S., Czartoryska, I., Gronowski, W., *Badania procesu redukowania średnicy końca rury metodą obciskania*, *Obróbka Plastyczna Metali*, T. 19, Nr 1, s. 21-27, 2008.
- [3] Mroczkowski, M., *Prognozowanie stateczności plastycznego płynięcia metali i ocena przydatności projektowanych narzędzi z wykorzystaniem metody elementów skończonych*, Akademia Górniczo-Hutnicza im. Stanisława Staszica, Kraków 2008.
- [4] *Prezentacja Technologie TCK*, Delphi Technical Center Kraków, Kraków 2008.
- [5] Norma PN-EN 10002-1, *Metale. Próba rozciągania. Część 1: Metoda badania w temperaturze otoczenia*, 2004.