

Effects of fuel tracing on nanoparticles from a Diesel engine

Nanoparticles from a HD-Diesel engine and their composition were investigated in the present paper. Three variants of fuel additives were applied to allow the balances of certain tracer-substances after the tests: 2% of additives-free lube oil; 2% of market lube oil with additive package and Fe-based regeneration additive (FBC) with 40 ppm Fe. The analysed SMPS particle size distributions indicated that by blending of the market lube oil to the fuel the combined effects of metals or metal oxides from the additive packages and of the heavy HC's from the lube oil matrix contribute the most to the increase of nuclei mode. From the masses of Fe, Zn and Ca, which were introduced with the fuel, only parts were found as integral masses at all ELPI-stages – Fe 43.5%, Zn 36.6%, Ca 65.5%. The majority of mass of some metals, or metal oxides emissions on ELPI-stages (up to 80%) is in the size ranges below 100 nm.

Key words: Diesel, emissions, nanoparticles, size-distribution, composition of particles

1. Introduction

Since January 2013, the nanoparticle counts emissions became a legal limited parameter for Diesel passenger cars in EU. This also provoked the research, discussions and perspectives of limitation for gasoline cars, first of all with direct injection [1].

The research questions are often: what is the composition of the finest particles? How much is the share of metals, metal oxides, soot and condensates [2, 3]? What is the influence of lube oil, or other additives?

One of the analytical methods, which is applied in the VERT-procedures since mid-90ties is the size-selective sampling of the aerosol on the ELPI-stages and a later analysis with very sensitive analytical techniques, like ICP-MS (inductively coupled plasma mass spectrometry) [4, 5, 6].

This method is applied as one of the most important analytical tools in the research of nanoparticles (NP) of gasoline engines with a particular focus on the composition of particles in nuclei mode (size range below c.a. 50 nm).

The lube oil and especially the increased lube oil consumption contribute to the NP-emissions in the sense of number concentrations in nuclei mode and composition [7, 8, 9].

In the present work a HD-Diesel engine was used to simulate the higher lube oil consumption and to compare the results with a case with no supplementary additive packages, or with the case of FBC known from the previous research. The influences of fuel tracing on nanoparticle emissions and the analysis of nanoparticle composition are principally valid for all types of diesel engines and were not treated in such a systematic way in own research or by the other researchers.

To simulate the increased lube oil consumption of the engine two lube oils were blended in the fuel, each one at 2% rate v/v:

- a DEA research oil consisting only of Parafins (mostly C14 to C20) without any additive packages; this additizing does not introduce any metals to the fuel and it can be considered in this respect as equal with a reference case (without fuel additizing), which was not tested here,

- a MOTOREX high quality market lube oil with additive package of which Ca & Zn can be regarded as tracer substances for the evaluation of results.

Another tracing was performed with Satacen, a Fe-based fuel borne catalyst (FBC) with a dosing of 40 ppm w/w Fe.

1.1. General information on emissions with fuel-additives

During the VERT project, experience was obtained regarding the properties of ultrafine particulates with different FBC's at engine-out conditions as well as downstream of the particulate traps, Fig. 1.

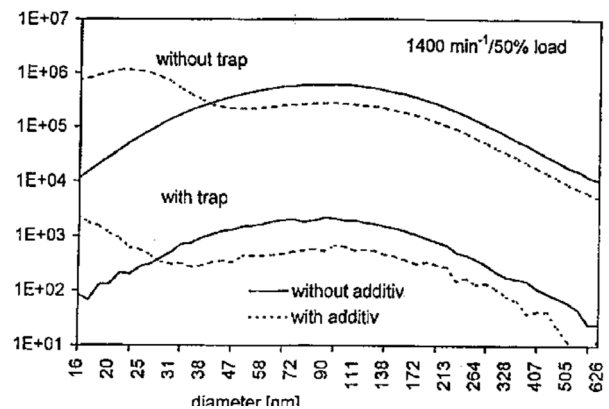

Fig. 1. Particle size distribution with/without additive

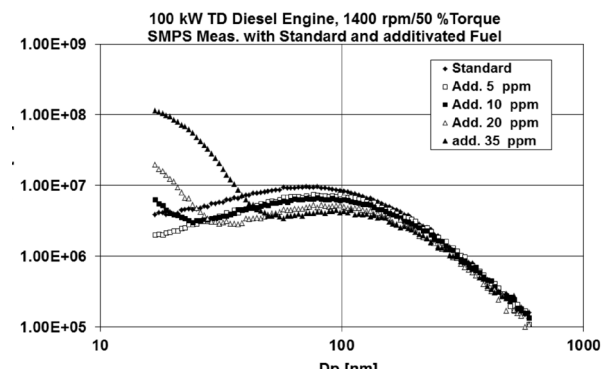

Fig. 2. Additive ash particle formation depending on concentration

In particular, it was found that fuel additives (called regeneration additives, FBC) mostly reduce particulate mass but increase the number count of ultrafine particles in some cases by two orders of magnitudes forming a clearly pronounced bimodal size distribution of engine-out solid particles. It was proven in previous cases that these were solid non-carbonaceous particles presumably consisting of clusters of primary metal-oxide particles in the size range around 20 nm, Fig. 2 [10, 11].

It was also shown that this bimodal distribution was dependent on the additive concentration in the fuel, very pronounced with high concentrations and nearly disappearing with lower concentrations where the additive was still equally active catalysing soot combustion.

Experience shows that the particulate traps have a very good filtration rate for carbon particulates and metal oxide particles.

2. Tested Engine, Fuel, Lubricants & FBC

2.1. Engine

The main data of the test engine are given in Tab. 1.

Table 1. Data of the research engine

Manufacturer	Liebherr Machines Bulle S.A., Bulle/Fribourg
Type	D934 S
Cylinder volume	6.36 dm ³
Rated engine speed	2000 rpm
Rated power	105 kW (ECU setting)
Model	4 cylinder in-line
Combustion process	direct injection
Injection pump	Bosch unit pumps
Supercharging	Turbocharger with intercooling
Emission control according to the requirements)	none (exhaust gas aftertreatment)
Development period:	2005, EU Stage III A

Figure 3 shows the engine and the ELPI apparatus for nanoparticle analytics in the laboratory for IC-engines, Berne University of Applied Sciences, Biel-Bienne and Fig. 4 represents the measuring set-up on this engine dynamometer.

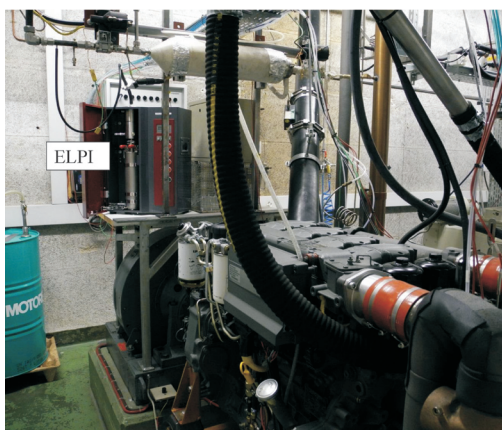

Fig. 3. ELPI measuring system with the Liebherr D 934 S engine.

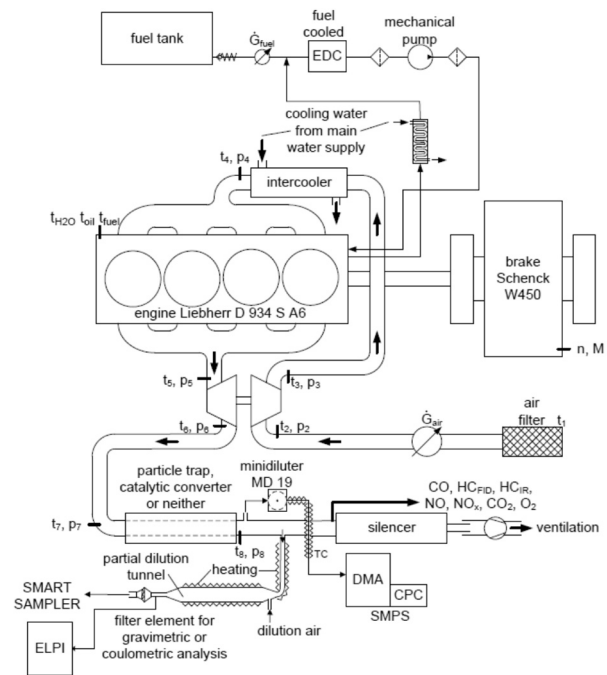

Fig. 4. Engine dynamometer and standard test equipment

2.2. Fuel

Following base fuel was used for the research:

Shell Formula Diesel fuel Swiss market summer quality (10 ppm S) according to SN EN 590.

2.3. Lubricants

The lube oil of the engine was: Lubrizol research oil OS No. 165108, blue, 15W/40; Tab. 2.

Table 2. Data of engine lubricating oil

Property	Unit	Value
Viscosity kin 100°C	mm ² /s	13.98
Pour point	°C	-25
Total Base Number TBN	mg KOH/g	8.4
Sulphur ashes	mg/kg	10 770
Sulphur	mg/kg	3 360
Mg	mg/kg	< 10
Zn	mg/kg	1 200
Ca	mg/kg	2 630
P	mg/kg	1 110

In order to simulate the increased lube oil consumption of the engine two lubricants were blended to the fuel at the rate 2% vol:

- the additive-free DEA research oil, consisting only of parafins, Tab. 3, which due to the absence of additives can be used as engine lubricant only for limited operating periods,
- a high quality market lube oil from MOTOREX, Tab. 4, with additive package, which makes difference to the DEA oil; some substances from this MOTOREX oil, like Ca & Zn can be used as tracers in the evaluation of results.

Table 3. Data of DEA research lube oil

Property	Unit	Parafol DEA 1420	Composition	% m
Density at 15°C	kg/m ³	780–790	C12	0.7
Viscosity at 20°C	mm ² /s	5	C14	25.2
Viscosity at 40°C	mm ² /s	3.1	C16	40.5
Pourpoint	°C	7	C18	21.0
Flame point, COC	°C	120	C20	8.4
Anilin point	°C	94	C22	2.8
“Boiling” start	°C	240–265	C24	0.7
“Boiling” end	°C	360	C26	0.7
Aromatics content	g/100 g	max. 0.1		
Sulphur content	ppm	< 1		

Table 4. Data of MOTOREX lube oil

Property	Unit	Value
SAE Grades		5W-30
Density at 15°C	g/ml	0.855
Flash point	°C	226
Pourpoint	°C	–39
Evaporative Loss (Noack)	% b.w.	11.1
Total Base Number (TBN)	Mg KOH/g	10.7
Sulphated Ash	% b.w.	1.36
Analysis of elements		
Ca	mg/kg	3680
Zn	mg/kg	1010
N	mg/kg	960
S	mg/kg	3250
P	mg/kg	930
Cl	mg/kg	13

2.4. FBC

As already explained in the previous section the metals or metal oxides from the regeneration additives produce increased NP count concentrations in the lowest size range (nuclei mode). In the present tests a Fe-based FBC, Satacen, was used with the increased dosing of 40 ppm w/w Fe.

3. Test Procedure & Instrumentation

3.1. Test-cycle and procedure (on engine dynamometer)

8 operating points of the ISO-cycle 8178 C/4 C1, which were used for testing emissions of construction site engines in the previous legislation steps were selected as the basis for the present emission measurements, Fig. 5 (symbols O):

The ISO 8 pts. test is used in the VERT/OAPC quality test procedures for testing of secondary emissions, [12] independently on the emission stage of the test engine.

The 8 operating points represent well an average of all engine operating collectives and the stationary operation allows: more exact calculations of mass flows and of dilution factors and establishing a more exact reference between the sampled and the “engine-out” results.

This testing procedure considers warm and in the majority of time stationary engine operation, which enables the scanning of particle size distributions and the basic investigation represented in this paper.

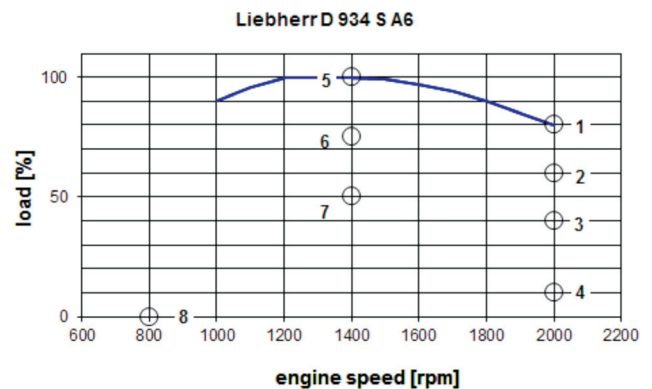

Fig. 5. Operating points of the ISO -8178. Test

The test is driven in the fixed sequence after a warm-up phase until engine coolant temperature reached > 83°C and lube-oil > 90°C.

3.2. Sampling lines and test-arrangement (on engine dynamometer)

2 sampling lines are used:

- sampling via Part-Flow-Dilution tunnel, or MD 19 Mini-diluter,
- for direct on-line size, count, and surface information using SMPS, NanoMet and ELPI,
- sampling of gas from the undiluted exhaust gas for the gaseous components.

3.3. Test Equipment for Exhaust Gas Emissions

The measurement is performed according to the Swiss exhaust gas emissions regulation for heavy duty vehicles (Directive 2005/55/ECE & ISO 8178):

Volatile components:

- Horiba exhaust gas measurement devices
Type VIA-510 for CO₂, CO, HCIR, O₂,
Type: Eco Physics CLD 822 for NO, NO_x,
- Amluk exhaust gas measurement device
Type FID 2010 for HCFID.

3.4. Particle counts & size analysis

To estimate the filtration efficiency of the DPF, the particle size and counts distributions were analysed with following apparatus:

- SMPS – Scanning Mobility Particle Sizer (DMA + CPC, TSI),
- MD19 tunable minidiluter – heated up to 80°C,
- Thermoconditioner (TC) (i.e. MD19 + postdilution, sample heating up to 300°C),
- ELPI – Electrical Low Pressure Impactor, DEKATI.

4. Size-Selective Analysis of NP-Composition

4.1. Sampling using ELPI

The ELPI (Electrical Low Pressure Impactor) as shown in block diagram Fig. 6 is a 13 stage cascade impactor that

measures particle number concentrations as a function of aerodynamic diameter.

The 13 impactor stages of ELPI operate in sequence, each with a smaller cutoff diameter.

By means of charging electrically the particles before they enter the cascade impactor and by measuring the currents at each impactor stage the number size distributions can be calculated. More information about ELPI functions can be found in [13, 14, 15].

In the present investigation the electrical signals of ELPI were not used to determine the size distribution or the total mass sampled. The ELPI-instrument was only used to collect size-specific samples for follow-up chemical analysis with respect to the collected substances.

The whole range from 30 to 10'000 nm is split into 13 stages (13 impactors + filter for the rest). After the test the collected material is available on these 13 deposition discs, it can be weighed to determine the mass and can be analyzed. In order to improve the quality of the chemical analysis special deposition films were used on these discs (films), consisting of Polycarbonate, which proved to be a very pure material.

The size distribution on the ELPI-stages is as follows, Tab. 5.

Table 5. Size Distribution of ELPI according to the manufacturer DEKATI

Stage	1	2	3	4	5	6	7
D 50% [µm]	0.03	0.06	0.108	0.17	0.26	0.41	0.65
Di [µm]	0.042	0.08	0.14	0.21	0.32	0.51	0.81

Stage	8	9	10	11	12	13	Backup
D 50% [µm]	1.02	1.65	2.52	4.40	6.80	10	Smaller than stage 1
Di [µm]	1.30	2.04	3.28	5.50	8.20		

4.2. Sample preparation and analysis

All samples were digested with acid mixtures in a microwave oven. The vessels used for the digestion should be carefully pre-cleaned and validated before use to achieve best detection limits.

All cleaning digestions must be verified using highly sensitive analytical techniques like ICP-MS (inductively coupled plasma mass spectrometry) to ensure that the vessel background levels are low enough for such ultra-trace analysis. Only ultra-clean vessels should be used.

Depending on the filter material and the pertinent target elements, sampling filters were digested with the following acid mixtures in a microwave oven:

- Nitric acid HNO₃
- a mixture of nitric acid HNO₃ and hydrogen peroxide H₂O₂
- a mixture of nitric acid and hydrochloric acid HCl

To answer the question, how much metal do we find on each size-plate, the following analytical technique was used:

Q-ICP-MS: in order to use the inductively coupled plasma quadrupole mass spectrometry the films has been acid-digested and the quartz filters acid leached by a mixture of nitric acid and hydrochloric acid in a microwave oven. The sample is then vaporized by a nebulizer and the smallest droplets of the forming spray are transported into inductively coupled argon plasma. At about 6000 K they aridred and the resulting particles are atomized and ionised. The ions pass an interface that transfers them to a quadrupole mass spectrometer where they are separated according to mass a subsequently counted.

This analytical technique is extremely sensitive: detection limit for Pt as well for Pd is on the impressively low level of 0.0004 µg / ELPI-stage and 0.0006 µg/ELPI-stage respectively.

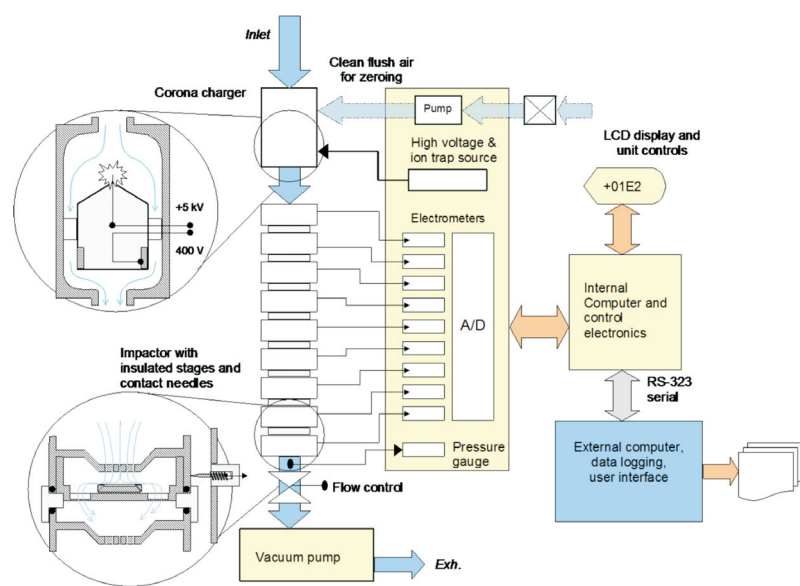

Fig. 6. ELPI block diagram (DEKATI)

Figure 7 shows an example of soot deposits on an ELPI filter plate.

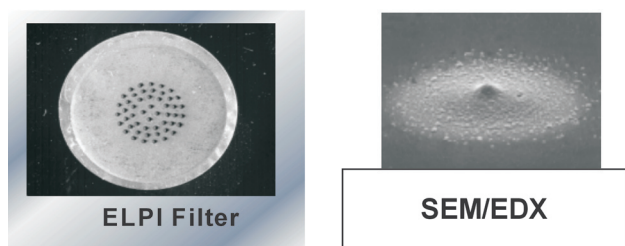

Fig. 7. Typical appearance of soot deposits on ELPI filter plates

Reliable results can only be achieved if the detection limit of the entire procedure, including sampling, sample preparation and analysis are determined. Therefore, blanks of fresh filter material and field-blanks (processed similarly to field sampling filters) need to be sampled, digested and determined.

Contamination risk and memory effects are not negligible especially for ubiquitous metals like Fe. Usually the metal determination is more limited by the sampling procedure and sampling preparation than by detection limits of the analytical method.

5. Results

The addition of DEA oil contained no supplementary metals or metal oxides as additive package. Therefore, from the point of view of generation the solid nanoparticles this variant is regarded as equal with baseline fuel. A separate baseline test was not performed in this project.

The results are presented in two parts: for gaseous and for particulate (NP) emissions and for the size selective PM-analysis.

5.1. Gaseous emissions & nanoparticles

The relationships of the emissions are similar or even identical at all operating points, so only the representative examples are illustrated. For gaseous emissions the rated speed (2000 rpm) offers 4 operating points with the low load (10%) OP. For the representation of PSD's the lowest, the highest and the intermediate OP's were chosen.

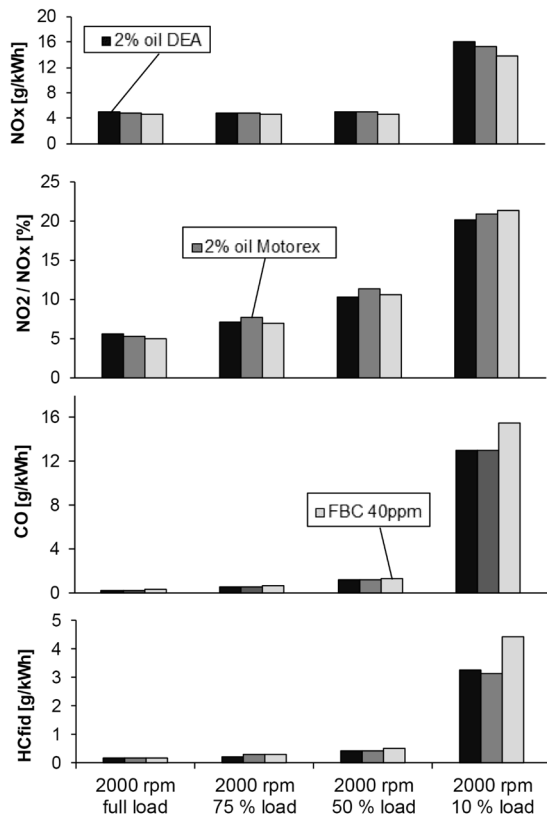

Fig. 8. Comparison of gaseous emissions at 2000 rpm
Figure 8 shows exemplary the gaseous emission compo-

nents at 2000 rpm with the three variants of additives in fuel (no exhaust gas aftertreatment). With Motorex lube oil there is a slight tendency of becoming higher CO- and HC-values at 2000 rpm. With FBC the higher CO- and HC are still more pronounced and especially at low load and idling. This can be explained with an intensified soot & SOF-post oxidation after the end of combustion in the combustion chamber.

At the low load OP4 (2000 rpm/10%) there are quite low exhaust temperatures in the range of 230°C before and 195°C after turbine. It must be supposed, that the oxidation in the exhaust line is nearly stopped.

Interesting is the look on NO_x and NO₂ at this OP4: with increasing amount of metals, or metal oxides (DEA → Motorex → FBC) there is a slight lowering of NO_x and an increase of NO₂. There is an abundance of oxygen (17.1%) and there are conditions in the combustion chamber after the end of combustion (tgas, O₂, time), which enable a partial oxidation of NO to NO₂ under the catalytic influence of the present metals. This is not the case at other operating points, also the OP's at 1400 rpm and idling, which are not represented here.

Figure 9 represents the SMPS particle size distributions (PSD's) at three operating points (OP's, 1, 7, and 8) with the three variants of additives in fuel.

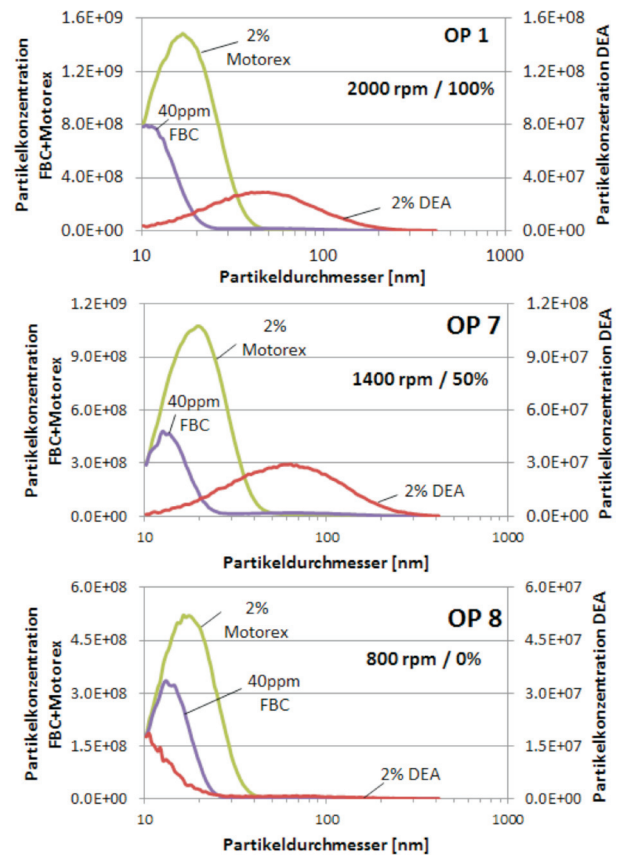

Fig. 9. SMPS size distribution OP's 1, 7, and 8

The highest NP count concentrations in nuclei mode (size range below approximately 30 nm) result for the blending of Motorex oil (2%) to the fuel. In this case the metal oxides particles from the additive package serve as condensation

seeds for heavier HC's, and the resulting mixture of solids and semi volatiles cannot be eliminated by the thermoconditioner.

The nuclei mode with FBC is also clearly increased but only to approximately half of the Motorex-level. FBC produces mostly solid NP's and it contains almost no heavy substances which would give origin to the heavy semi volatiles (SOF).

The PSD's with DEA oil (blended at 2%) show no increased nuclei mode at all (see another scale for DEA in Fig. 8). This is evident, when keeping in mind the composition of DEA oil (see data Tab. 2). The results with DEA can be regarded as reference, responding to the non-additives fuel.

At idling (OP8), nevertheless, DEA shows also an increased nuclei mode – nanoparticles originating from the engine lube oil.

The results at all other operating points (OP: 2, 3, 4, 5, 6 not represented here) show identical tendencies and relationships between these 3 variants, as OP 1 & OP 7.

It can be stated that the combined effects of metals or metal oxides from the additive packages and of the heavy HC's from the lube oil matrix contribute the most to the increase of nuclei mode.

5.2. ELPI Size-selective emissions, 8 pts

Figure 10 summarizes the amounts of Fe, Ca & Zn on the single stages of ELPI, collected during whole 8 pts-test. The back-up filter-plate collected the smallest fractions below 30 nm.

For Iron there are with FBC the highest amounts on the four lowest stages, which means that Fe produces the highest portion of mass emitted as nanoparticles below 108 nm of size. Comparing to the other fuels there is a clearly higher mass of Fe on almost all stages and the use of FBC (Fe) as tracer substance is well confirmed.

Regarding Calcium the very high emission for DEA in the back-up and in the 2nd stage is surprising.

On the other hand there are many stages (4, 7, 10, 11, and 13) with the highest amount of Ca for the fuel with FBC addition. The supplementary dosing of Ca with Motorex oil is visible only in four stages (1, 3, 5 and 8).

There are other sources of Ca-emission from the actual engine lube oil and it seems that the increased Ca-values are produced randomly in different particle size ranges.

Finally Ca must be regarded as not appropriate to be used as a tracer element.

Zink shows in all stages the highest amount for Motorex oil and a clear effect of the supplementary oil dosing in the fuel.

Table 6 summarizes the masses of elements Fe, Ca & Zn, which were found on the ELPI stages: all particle sizes, four smallest sizes and mass- percentage of the four smallest sizes. It can be stated that the trace substances Fe, Ca and Zn are present in the nanoaerosol in majority of mass (Fe 79%, Ca 75% and Zn 77%) at the lowest particle sizes below 100 nm. For Calcium (Motorex) nevertheless, it is not sure, how is the interference of other emission sources (like for Ca from DEA).

The summary masses of elements (Fe, Ca, and Zn) from all ELPI stages were recalculated for the entire exhaust gas mass, which passed through the engine during each respective 8 pts-test.

Moreover, the masses of elements which were dosed to the fuel during the tests were calculated (dosed tracer substances).

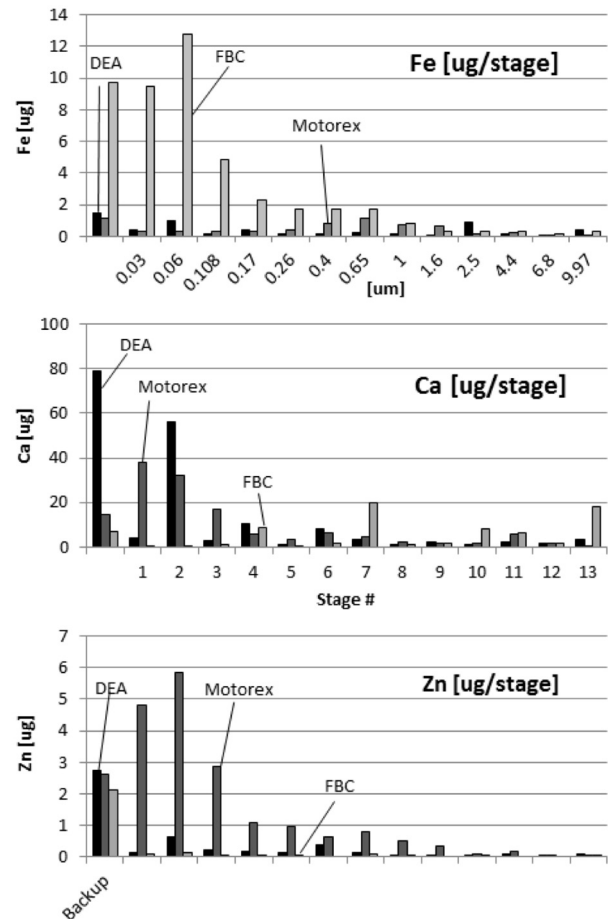

Fig. 10. Size-selective emissions in 8 pts-test

Table 6. Summary emissions on ELPI stages: all sizes, four smallest sizes and %-portion of four smallest sizes

		∑ all stages	∑ back-up + stage 1,2,3	% mass back-up + stage 1,2,3
Fe [ug]	DEA	5.84	3.02	51.8
	Motorex	6.65	2.13	32.0
	FBC	46.36	36.72	79.2
Ca [ug]	DEA	177.64	142.26	80.1
	Motorex	136.25	101.94	74.8
	FBC	77.89	9.44	12.1
Zn [ug]	DEA	4.99	3.78	75.6
	Motorex	20.87	16.11	77.2
	FBC	2.65	2.42	91.3

Figure 11 compares the integral emissions of Fe, Ca & Zn, which were measured on the ELPI-stages with the integral dosed masses introduced with fuel during the test.

For Iron it can be remarked:

- the variants of fuel DEA & Motorex emit similar masses of Fe (in the range 0.06 g/test),
- the fuel with FBC causes a clearly higher emission of 0.43 g/test,
- the dosed mass was 0.99 g/test Fe,
- from the Fe dosed with FBC 43.5% of mass was found as integral mass at all ELPI-stages.

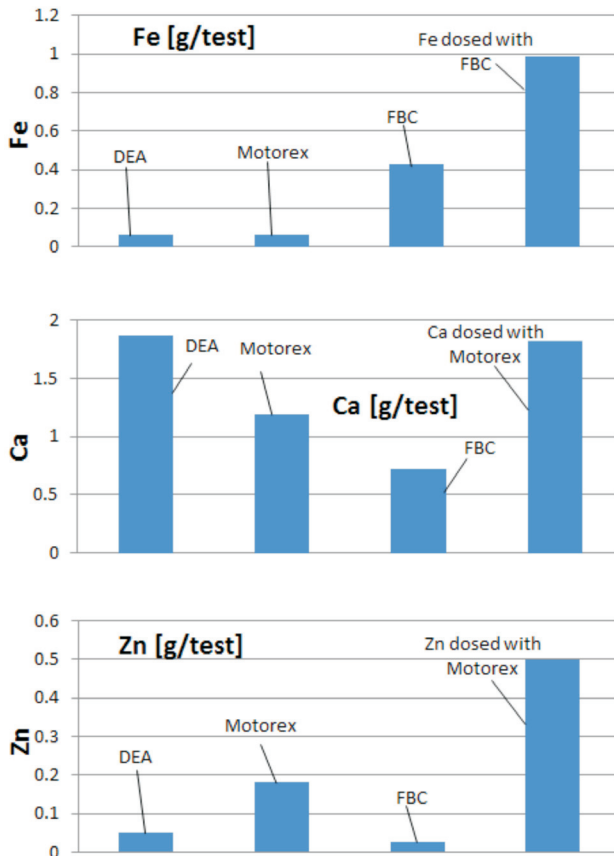

Fig. 11. Comparison of measured emissions & dosed tracer

Summarizing: the tracing with Fe is visible by increasing the Fe emission (here 7 times), nevertheless more than half of the dosed Fe stays in the engine.

For Calcium there are no logical relationships between the masses: “dosed” (Motorex) and “not dosed” (DEA & FBC) and contribution of the additives. It must be supposed that there are strong store/release effects of Ca in the system, which overlapped the testing efforts,

- from the Ca dosed with Motorex oil 65.5% of mass was found as integral mass at all ELPI-stages.

For Zinc the emission with Motorex (dosed) is 3.5 – 7.3 times higher, than with DEA & FBC (not dosed), but it is also nearly 1/3 of the mass introduced by additives,

- from the Zn dosed with Motorex oil 36.6% of mass was found as integral mass at all ELPI-stages.

The effects which are observed with Zn are similar, as with Fe and both of them can be regarded as appropriate tracer substances.

6. Conclusions

The results can be summarized as follows:

- the SMPS particle size distributions show the highest increase of nanoparticle count concentrations in the nuclei mode (below 30 nm) with blending of 2% market oil (Motorex) to the fuel; with FBC 40ppm Fe this increased nuclei mode is lower and with 2% DEA oil there is no increase of NP-concentrations in nuclei mode,
- by blending of the market lube oil to the fuel the combined effects of metals or metal oxides from the additive packages and of the heavy HC’s from the lube oil matrix contribute the most to the increase of nuclei mode,
- in the size-selective analysis Fe & Zn were found according to the dosing in majority of mass at the ELPI-stages below 100 nm: Fe 79% mass, Zn 77% mass,
- from the Fe dosed with FBC 43.5% of mass was found as integral mass at all ELPI-stages,
- from the Zn dosed with Motorex oil 36.6% of mass was found as integral mass at all ELPI-stages,
- Ca was found to be unappropriated as a tracer substance since the results were overlapped by other Ca-sources (engine lube oil) and some ELPI-stages without Ca-dosing showed higher emissions, than with Ca-dosing,
- from the Ca dosed with Motorex oil 65.5% of mass was found as integral mass at all ELPI-stages,

With these results it is confirmed, that the investigated metals, or metal oxides are emitted mostly in the lowest size range of the nanoaerosol, below 100 nm. The size selective sampling and analysis were confirmed as appropriate tools for investigations.

Definitions/Abbreviations

AFHB	Abgasprüfstelle FH Biel, CH
BAFU	Bundesamt für Umwelt, (Swiss EPA)
BfE	Bundesamt für Energie
CFPP	cold filter plugging point
CLD	chemoluminescence detector
CNC	condensation nuclei counter
CPC	condensation particle counter
DC	Diffusion Charging sensor
DI	Direct Injection
DMA	differential mobility analyzer
DPF	Diesel Particle Filter
EC	Elemental carbon, European Community
ECU	electronic control unit
EDX	Energy dispersive x-ray detection
ELPI	Electric low pressure impactor
EMPA	Eidgenössische Material Prüf- und Forschungsanstalt, CH
FBC	Fuel Borne Catalyst = Fuel Additive = Regeneration Additive
FHNW	Fachhochschule Nordwest CH
FID	flame ionization detector
FOEN	Federal Office of Environment (BAFU), CH
HD	heavy duty
ICE	internal combustion engines
ICP-MS	Inductively coupled plasma mass spectrometry
JRC	EC Joint Research Center
LRV	Luftreinhalteverordnung, CH

ME	Matter Engineering, CH	PC	particle counts
MD19	heated minidiluter	PM	particulate matter, particle mass
NanoMet	NanoMetnanoparticle summary surface analyser (PAS + DC + MD19)	PSD	particle size distribution
NDIR	nondispersive infrared	PSI	Paul Scherrer Institute
NP	nanoparticles < 999 nm (SMPS–range)	SEM	Scanning Electron Microscopy
OAPC	Ordinance on Air Pollution Control	SMPS	Scanning Mobility Particle Sizer
OC	Organic carbon	TC	thermoconditioner, Total Carbon
OEM	original equipment manufacturer	TEM	Transient Electron Microscopy
OP	operating point	TTM	Technik Thermische Maschinen, CH
PAH	Polycyclic Aromatic Hydrocarbons	ULSD	ultra low sulfur Diesel
PAS	Photoelectric Aerosol Sensor	VERT	Verification of Emission Reduction Technologies (International Industry Association)

Bibliography

- [1] Merkisz, J., Pielecha, J., Radzimirski, S. New Trends in Emission Control in the European Union. Springer 2014, VIII, 170 p. 131 illus. ISSN 2194-8119, ISBN 978-3-319-02704-3.
- [2] Mathis, U., Kaegi, R., Mohr, M., Zenobi, R. TEM analysis of volatile nanoparticles from particle trap equipped diesel and direct-injection spark-ignition vehicles. Atmospheric Environment 38 (2004) 4347-4355, April 2004
- [3] Liati, A., Schreiber, D., Dimopoulos Eggenschwiler, P., Dasilva, Y.A.R. Metal Particle Emissions in the Exhaust Stream of Diesel Engines: An Electron Microscope Study. Environmental Science & Technology, 2013, 47, 14495-14501.
- [4] Mayer, A., Czerwinski, J., Matter, U., Wyser, M., Scheidegger, Kieser, D., Weidhofer: VERT: Diesel Nano-Particulate Emissions: Properties and Reduction Strategies. SAE Technical Paper Nr. 980539, February 1998.
- [5] Mayer, A., Czerwinski, J., Ulrich, A., Wichser, A., Kasper, M., Mooney, J. Metal-Oxide Particles in Combustion Engines Exhaust. SAE Technical Paper 2010-01-0792.
- [6] Mayer, A., Czerwinski, J., Kasper, M., Ulrich, A., Mooney, J.J. Metal Oxide Particle Emissions from Diesel and Petrol Engines. SAE Technical Paper 2012-01-0841.
- [7] Buchholz, B.A., Dibble R.W., Rich, D., Cheng, A.S. Quantifying the contribution of lubrication oil carbon to particulate emissions from a diesel engine. SAE Technical Paper Nr. 2003-01-1987.
- [8] Bardasz, E.A., Cowling, S., Panesar, A., Durham, J., Tadrous, T.N. Effects of lubricant derived chemistries on performance of the catalyzed diesel particulate filters. SAE Technical Paper 2005-01-2168.
- [9] Vaaraslahti, K., Keskinen, J., Giechaskiel, B. Solla, A., Murtonen, T., Vesala, H. Effect of lubricant on the formation of heavy-duty diesel exhaust nanoparticles. Environmental Science & Technology, 2005, 39 (21), 8497-8504.
- [10] Kasper, M., Matter, U., Burtscher, H. NanoMet: On-Line Characterization of Nanoparticle Size and Composition. SAE Technical Paper 2000-01-1998.
- [11] Mayer, A., Ulrich, A., Czerwinski, J., Matter, U., Wyser, M. Retention of Fuel Borne Catalyst Particles by Diesel Particle Filter Systems. SAE Technical Paper 2003-01-0287.
- [12] Testing particle filter systems for internal combustion engines. Swiss Norm SN 277 206, Febr. 2011.
- [13] Marjamäki, M., Ntziachristos, L., Virtanen, A., Ristimäki, J. et al., "Electrical Filter Stage for the ELPI," SAE Technical Paper 2002-01-0055, 2002, doi:10.4271/2002-01-0055.
- [14] <http://www.dekati.com>
- [15] Järvinen, A., Aitoma, M., Rostedt, A., Keskinen, J., Yli-Ojanperä, J. Calibration of the new Electrical Low Pressure Impactor (ELPI+). Journal of Aerosol Science, vol 69, pp. 150-159.

Prof. Jan Czerwiński, DEng. – Laboratorium for IC-Engines and Exhaust Gas Control, University of Applied Sciences Biel-Bienne, Switzerland.

Prof. dr Jan Czerwiński – Laboratorium Silników Spalinowych i Emisji Spalin, Uniwersytet Nauk Stosowanych w Biel-Bienne, Szwajcaria.

e-mail: jan.czerwinski@bfh.ch



Andreas Mayer, MEng. – Technik Thermische Maschinen (TTM), Switzerland.

Inż. Andreas Mayer – pracownik Termodynamicznej Techniki Maszyn (TTM), Szwajcaria.

e-mail: tm.a.mayer@bluewin.ch



Mr. Adrian Wichser – EMPA, Swiss Federal Laboratories for Material Testing and Research, Switzerland.

Adrian Wichser – EMPA, Szwajcarskie Federalne Laboratorium Inżynierii Materiałowej i Technologii, Szwajcaria.

e-mail: Adrian.Wichser@empa.ch

