

---

# Inżynieria Bezpieczeństwa Obiektów Antropogenicznych

---

## REALIBILITY OF THE LARGE-SIZE POST-TENSIONED SLAB-ON-GRADE

### *Niezawodność wielkogabarytowego kablobetonu jako płyt fundamentowych*

**Andrei V. Tur**

*Ass. Professor, PhD, Department of Building Structures, Brest State Technical University,  
aturphd@gmail.com*

**Viktar V. Tur**

*Professor, D. Sc., PhD, Department of Concrete Technology, Brest State Technical University,  
Bialystok University of Technology, profturvic@gmail.com*

---

#### **Abstract**

The present article describes some of the possible ways of usage of the post-tensioned flat slabs and the rational design procedures to provide their structural reliability. Theoretical background of the punching resistance checking, in the case when the piles support the foundation post-tensioned slabs, is presented. For ground floor slabs, an iterative method is given for determining design compression pre-stresses distribution in slab sections, taking into account the restrained effect created by the friction shear stresses in contact between slab and the base. In addition, the article presents some practical implementations of the post-tensioned slabs as an artificial base in the presence of weak soils and as a large-size ground floor (slab-on-grade) without any joints.

**Key words:** post-tensioned slab, punching shear, slab-on-grade.

---

#### **Streszczenie**

W artykule opisano niektóre z możliwych sposobów wykorzystania płyt kablobetonowych oraz racjonalne procedury projektowe zapewniające ich niezawodność konstrukcyjną. Przedstawiono tło teoretyczne sprawdzenia wytrzymałości na przebicie w przypadku, gdy pale podtrzymują płyty fundamentowe są wstępnie naprężone. W przypadku płyt fundamentowych podano iteracyjną metodę wyznaczania obliczeniowego rozkładu naprężeń ściskających w przekrojach płyt, uwzględniającą efekt utwierdzenia wywołany naprężeniami ścinającymi w kontakcie płyty z podstawą. Ponadto, w artykule przedstawiono kilka praktycznych zastosowań płyt naprężonych jako sztucznego podłoża na gruntach słabych oraz jako wielkogabarytowe podłoże gruntowe (slab-on-grade) bez żadnych spoin.

**Słowa kluczowe:** kablobeton, płyty fundamentowe.

---

#### **1. Introduction**

Currently, in international and national practice of design, post-tensioned slabs on the various types of subgrade are becoming increasingly common. When post-tensioned slabs are used, the pre-stress (post-tension) dualism should be taken into account: on the one hand, it is the unloading effect created by un-bonded tendons, and on the other, effects caused by the

compression stress development in the concrete slab during the tendons tensioning process. The unloading effect of post-tensioning (equivalent transverse loads creation) obtained as a result of rational arrangement (tracing) of the tendons is usually considered in combinations of actions (or effects of actions) and not included in the resistance models, in particular, punching shear resistance.

It should be noted that the use of post-tension during the construction of slab, in addition, allows excluding shrinkage and temperature cracking of concrete, especially at an early age. The technology of post-tension allows to carry out step-by-step tension of the tendons starting from the moment when the concrete reaches the initial transfer strength. This creates opportunities for the construction of the large-sized slabs with small number of deformation joints, or even without any joints. It should be noted, that a large number of joints could lead to high costs in the restoration of fragments of slab and pneumatic tires of stackers. In addition, in the absence of joints, all the legs of the racks are located in the internal field of the slab, which excludes damage in the sections of slab that are situated near the corners and edges of the slab. In the modern logistics centers there are strict requirements for the flatness of the slabs due to the technological features of loading onto pallets and preventing tipping of the technological equipment.

The reliability of the structural system depends on the reliability of the foundation related with the mechanical characteristics of the base (base layer, subsoil). When the structural systems are located in areas with the weak soils, the choice of the optimal design solution, in addition to reliability, can significantly influence the economic component. In the case of the concrete ground floors designing, it is possible to eliminate uncertainties by specifying the required characteristics of the base (subgrade minimum modulus of reaction).

## 2. Checking of the punching resistance of the post-tensioned slabs

When the structural system is located in the zone of weak soils, a good design solution may be the usage of an artificial foundation in the form of a post-tensioned slab supported on piles. With the adopted geometrical sizes of the cross section of the piles and the thickness of the slab, one of the most important part of the ULS- design procedure is checking of punching resistance.

Due to the fact that the Structural Codes do not contain clear models for the local shear (punching) resistance in case of the post-tensioned flat slabs, a modified design method based on the elements of the so-called “decompression approach” [1, 2] proposed. In the framework of this method, the state of decompression defined as a state in which the preliminary compression (pre-stressing by post-tensioned tendons) of concrete at the level of the most tensioned face under the imposed actions canceled to zero.

According to [1], the *effective value* of the punching force  $V_{Ed,eff}$  should be determined as the resultant of the shear stresses uniformly distributed along the length of the control perimeter. At the same time, the intensity of shear stresses is assumed to be equal to the maximum value of shear stresses caused by the punching force applied with eccentricity relative to the axis of the pile.

According to [3] value of the effective punching force is equal to:

$$V_{Ed,eff} = \beta \cdot V_{Ed}(p), \quad (1.1)$$

where  $\beta$  is a coefficient accounting for concentration of the shear forces as defined in [3].

The effect of post-tension should be taken into account in the magnitude of the effective punching force: a transverse (vertical) component of the compression force  $V_{Ed}(p)$  and the effect of the compression force in the plane of the slab  $V_{p,0}$ :

$$V_{Ed,eff} = \beta \cdot V_{Ed}(p, P) - V_{p,0}, \quad (1.2)$$

Scheme for calculating of the equivalent post-tension forces acting perpendicular to the slab plane shown in Figure 1.1. Internal forces (considered as responses) transmitted directly to the column (within the control perimeter of the punching) does not take into account because these responses not affecting the design value of the shear stresses acting along the length of the control perimeter.

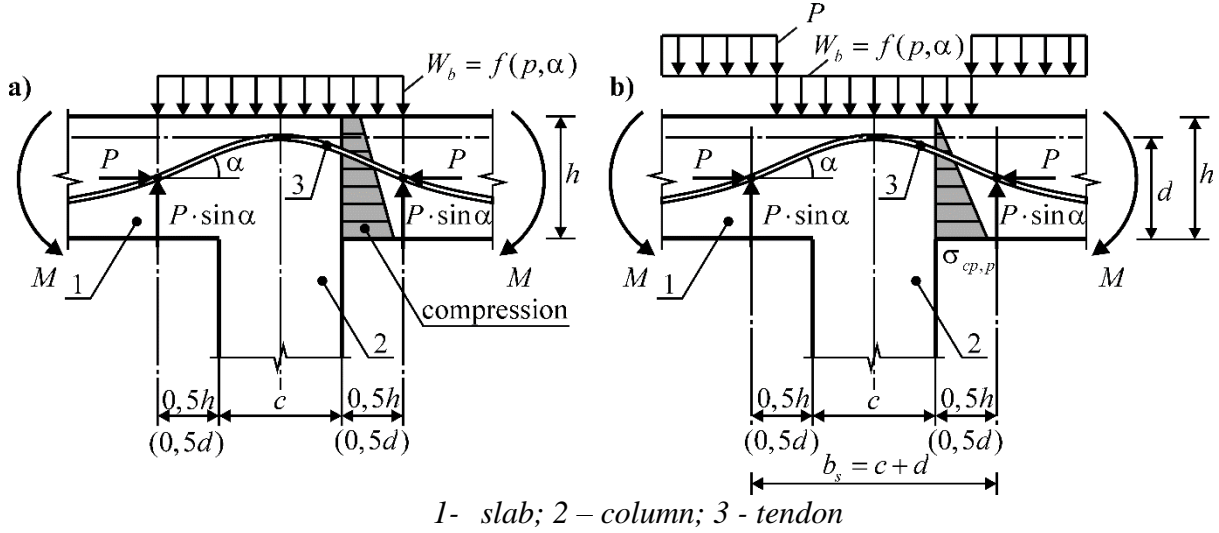

1- slab; 2 – column; 3 - tendon  
 Figure 1.1. The scheme of forces for determining the vertical and horizontal component of the compression force (a) before the application of the vertical loads; (b) state of decompression

In accordance with [5], it is assumed that the **vertical component** of the post-tension should be determined taking into account the forces acting in the tendons located inside the perimeter, spaced at a distance  $0.5h$  from the column face. Assigned that within the area limited by this perimeter all loads transmitted directly to the pile rack (see Figure 1.1). This is equivalent to reducing the effective punching force by  $\sum_{i=1}^n (P_{m,\infty} \cdot \sin \alpha)_i$  (where  $n$  - number of tendons passing through the considered control perimeter).

According to [1, 2], when the tendons are situated outside the control perimeter  $0.5h$  from the face of the support, the effect of post-tension, in particular the vertical component of compression, is substantially reduced. Taking into account the results of the experimental tests [6] and results of the own studies, it is recommended to design post-tensioned slabs with tendons located on the slab strip with the width no more than  $c+d$  ( $c$  – column size,  $d$  – effective depth of the slab, see Figure 1.1). At the same time, at least two tendons should be placed inside the region limited by vertical reinforcement bars of the column.

Based on the provisions of the **decompression** approach, the shear force (decompression force) corresponding to zero compressive stresses on the most tension fiber of the slab section, at various levels of slab compression in orthogonal directions, determines:

$$V_{p,0} = \frac{P_{0,y} \cdot b_x + P_{0,x} \cdot b_y}{b_x + b_y}, \quad (1.3)$$

where  $b_x, b_y$  is the dimensions of the control perimeter along the axes  $x, y$ ;  $P_{0,x}, P_{0,y}$  is the decompression forces in axle direction  $x, y$ .

For determining the values of  $P_{0,x}, P_{0,y}$ , the following assumption is adopted: the decompression force is a punching force that corresponds to the bending moment causing

tensile stresses on the top face of the slab section, numerically equal to the compressive stresses from the horizontal projection of the compression (pre-stressing) force.

For each orthogonal direction, the decompression force can be determined as a part of the design punching force  $V_{Ed}(p, P)$  and the design bending moments  $M_{Ed,x}(p, P)$  and  $M_{Ed,y}(p, P)$ :

$$\frac{P_{0,x}}{V_{Ed}(p, P)} = \frac{M_{0,y}}{M_{Ed,y}(p, P)}, \quad (1.4)$$

and

$$\frac{P_{0,y}}{V_{Ed}(p, P)} = \frac{M_{0,x}}{M_{Ed,x}(p, P)}. \quad (1.5)$$

where  $M_{Ed,x}(p, P)$ ,  $M_{Ed,y}(p, P)$  is the total bending moments acting along the column face in width  $b_x$ ,  $b_y$ , and determined from linear analysis;  $M_{0,x}$ ,  $M_{0,y}$  - moments of decompression, defined on the width of the slab  $b_x$ ,  $b_y$  and determined according to formulas (1.6), (1.7):

$$M_{0,x} = \frac{\sigma_{cp,x} \cdot b_x \cdot h^2}{6}, \quad (1.6)$$

$$M_{0,y} = \frac{\sigma_{cp,y} \cdot b_y \cdot h^2}{6}, \quad (1.7)$$

where  $\sigma_{cp,x}$ ,  $\sigma_{cp,y}$  is the average values of the stresses in the concrete slab (at the level of the center of gravity of the section) created by the axial (pre-stressing) force of the strip width  $b_x$ ,  $b_y$ .

The modified provisions of the decompression approach to the punching resistance checking are set out in the **fib** MC2010 [4]. Within the framework of the adopted decompression approach, the moment of decompression is taken into account when calculating the angle of rotation  $\psi$ :

$$\psi = 1,5 \cdot \frac{V_s}{d} \cdot \frac{f_{yd}}{E_s} \cdot \left( \frac{m_{Ed} - m_{0,d}}{m_{Rd} - m_{0,d}} \right)^{1,5}, \quad (1.8)$$

where  $m_{0,d}$  is the average value of the moment of decompression ( $kNm/m$ ), acting in the bearing strip.

### 3. Design method for determining compression pre-stresses distribution in slab sections, taking into account the additional shear forces caused by the friction in contact

When designing ground floor without joints, one of the main tasks is to avoid shrinkage cracking. The required value of the post-tension (compression) force in the first approximation is determined from the condition of ensuring the deformation (displacement) of the slab in contact with the base. Based on this requirement, the so-called "mobilization" condition of the slab represents the following inequality:

$$\sum P_{max} \geq T_{friction} \quad (2.1)$$

where  $\sum P_{max}$  is the total compression (pre-stressing) force required to overcome the friction force in contact with the base ( $\sum P_{max} = P_{max,i} n$ ,  $n$  is the number of tendons per unit length of the slab,  $P_{max,i}$  is the required tension force in a single tension member).

$T_{friction}$  is the contact friction force determined by:

$$T_{friction} = h \cdot \rho \cdot \frac{L}{2} \cdot b_0 \cdot \mu_j, \quad (2.2)$$

where  $h$  is the slab depth;  $\rho$  is the density of concrete;  $b_0$  is the slab width (1 m);  $\mu_j$  is the coefficient of friction on the contact slab with the base ( $\mu_j=0.75$  for plastic film laid on concrete base).

Then:

$$P_{max,i} \cdot n \geq h \cdot \rho \cdot \frac{L}{2} \cdot b_0 \cdot \mu_j \cdot \gamma_{p.fav} \quad (2.3)$$

Taking into account the shear stresses developing along the contact of the slab with the base as a result of friction forces, the distribution of the compression stresses (pre-stresses)  $\sigma_{cp,i}(x)$  in sections along the length of the slab is determined using the iterative procedure for the following system of equations (2.4) (see Figure 2.1):

$$\begin{cases} \sigma_{cp(i+1)}^{(j)} = \sigma_{cp(i)}^{(j)} + \tau_x^{(j)} \frac{\Delta h}{h} \\ \delta_{(i+1)}^{(j)} = \delta_{(i)}^{(j)} + \Delta x \left( \frac{\varepsilon_{c,i+1}^{(j)} + \varepsilon_{c,i}^{(j)}}{2} \right) \end{cases} \quad (2.4)$$

In the first iteration, value of the displacement of slab end section  $x = 0$  (assuming that the friction coefficient is equal to zero) is determined:

$$\delta_{(i)}^{(1)} \leq \frac{P_{m,0}(x=0) \cdot L/2}{h \cdot b_0 \cdot E_{cm}(t)} \quad (2.5)$$

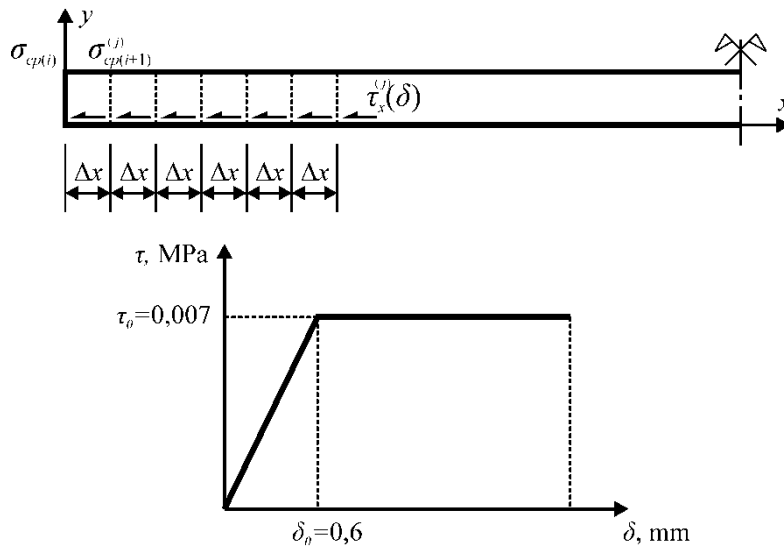

Figure 2.1. To the calculation of the pre-stress distribution

The bi-linear diagram (see Figure 2.1) presents the relationship between the interface shear stresses and displacements for the base with a polyethylene film utilizing in the form of a sliding layer. The practical application of this procedure is presented in section 3.

### 3. Some examples of the practical implementations of the post-tensioned slab-on-grade

As an *example 1*, consider the project of a foundation for an automated warehouse complex with a height of 30 m and a size in plan of 64.7 x 51.6 m. The load on the single racks range from 20-40 tons. The warehouse is divided into 4 zones with different temperature condition (from -24 to +1°C), which leads to special requirements for the design of the foundation slab.

According to the results of engineering and geological surveys, the construction site characterized by the fact that it was necessary to carry out refining at a depth of 6 m to 8 m with subsequent construction of an artificial ground base. To exclude such costly technological operations, it was decided to create an artificial base in the form of a post-tensioned slab 300 mm thick without joints (bottom slab), based on pilework to exclude punching (see Figure 3.1). The tracing of the post-tensioned tendons (see Figure 3.2), their number and the value of the tension force taken based on the limitation of allowable deflection under the frequent combination of the actions of the overlying layers and compensation of shrinkage stresses.

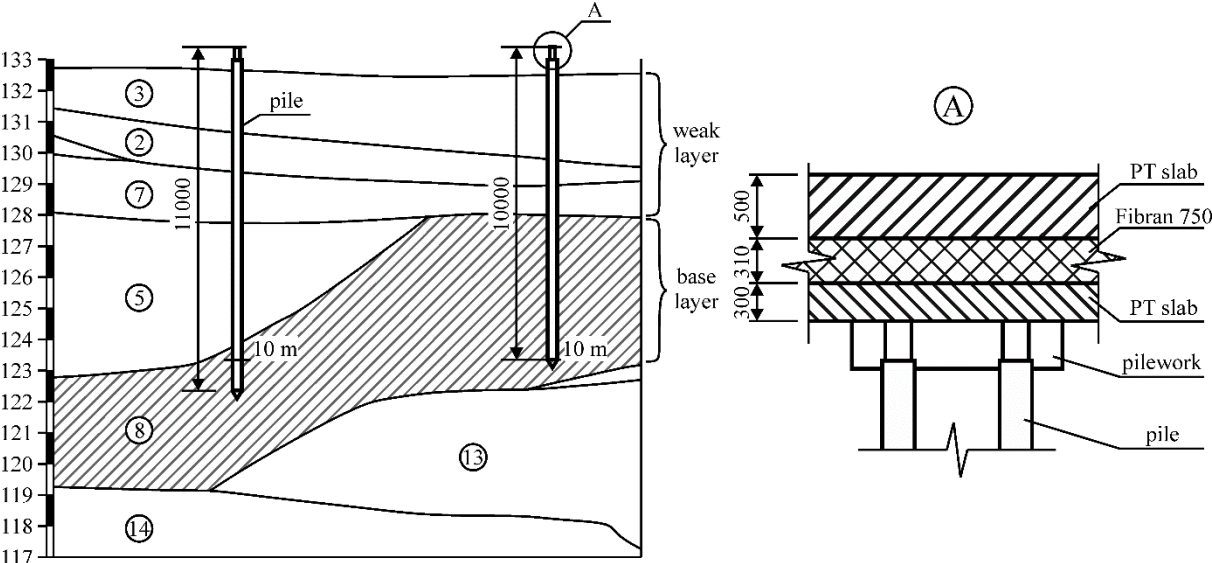

Figure 3.1. Geological survey's results and construction of foundation

The top post-tensioned slab (linear tracing in both directions) has a depth of 500 mm (see Figure 3.3), loaded by concentrate force from the legs of the racks and transfers to the underlying layers as a rigid stamp. The depth of the slab was determined based on the required flexural stiffness and the checking for the punching resistance. As a base for the top slab, a middle layer of Fibran 750 taken, for which it was necessary to control the value of the maximum strain and according stiffness characteristics. Stiffness characteristic of the Fibran 750, as a base of the slab, was obtained based on special laboratory testing and characterized by stiffness coefficient  $k=40 \text{ MN/m}^3$ . Concentrate loads from the legs of the racks resulted in equivalent uniformly distributed loads causing the same deflection of top slab. This imposed load value was used for the ULS and SLS checking of bottom slab.

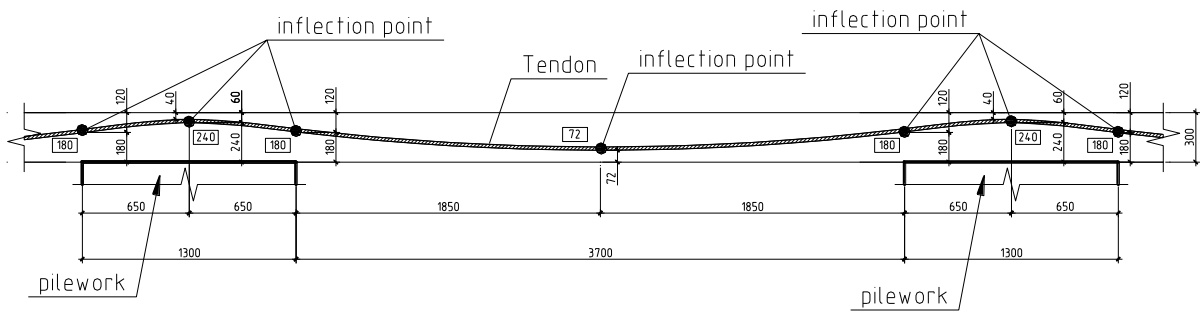

Figure 3.2. Tracing of the tendons



Figure 3.3. Top slab reinforcement

As an *example 2*, consider the project of a large-size 144x72 m post-tensioned slab-on-grade (ground floor) without joints (see Figure 3.4, 3.5).

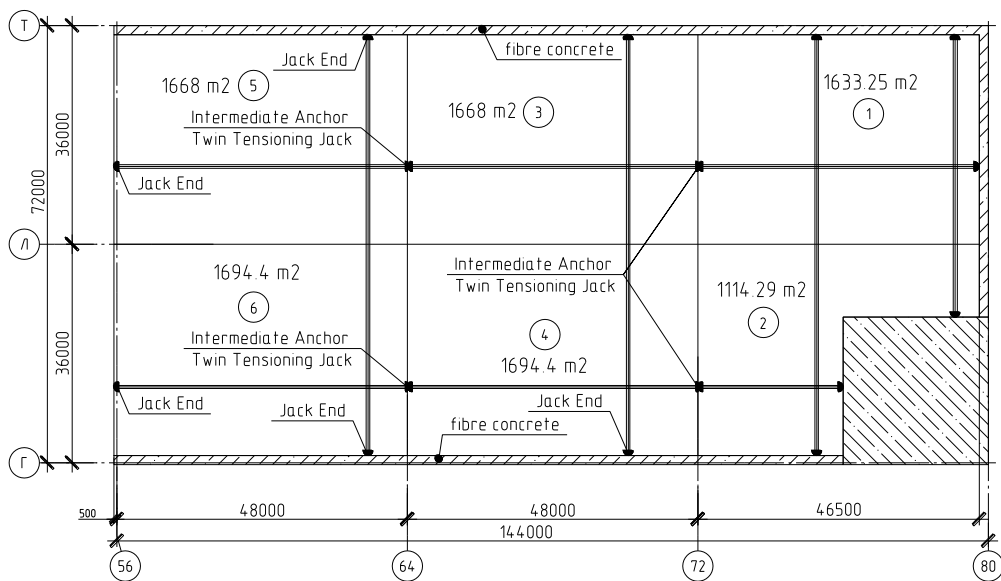

Figure 3.4. Slab plan with tendon profile

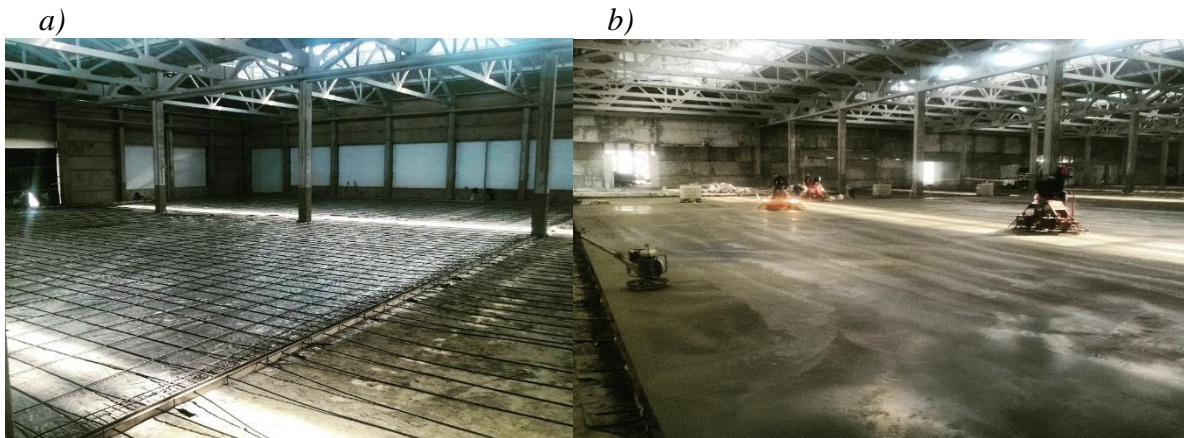

Figure 3.5. Tendon layout in formwork (a) and slab after concreting (b)

According to (2.4) and Fig. 2.1 pre-stress distribution in the slab cross-sections along the length of the slab, taking into account frictionshown in Fig. 3.5:

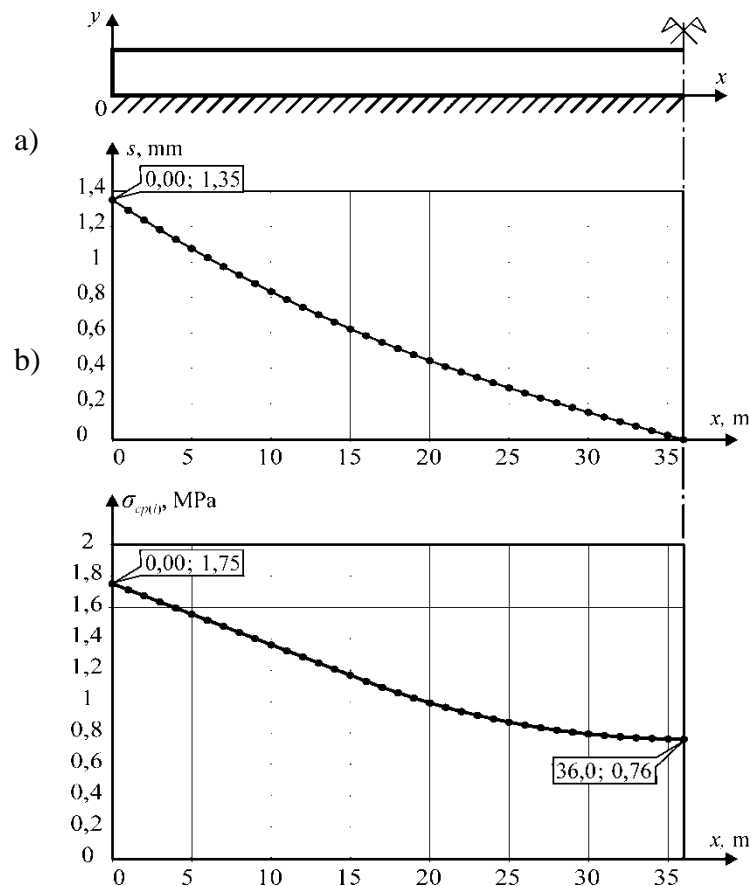

Figure 3.6. Displacements (slippage) (a) and pre-stress distribution (b) along the length of the slab (half of the length-symmetrically)

### Conclusion

The use of the post-tension when designing foundation and ground floor slab-on-grade allows for high reliability and rational materials consumption. At the same time, post-tension forces should be considered not only when determining effective vertical loads,



unloading spans and directly reducing the resulting pushing forces, but also additional shear forces corresponding to the state of decompression. The experience of practical application and exploitation of this type of post-tensioned structures reflect higher exploitation parameters and durability slab in the different environmental conditions.

### References

- 1) Regan P.E. The punching resistance of prestressed concrete slabs / Proceedings, Institution of Civil Engineers – 1985, N79 – p. p 657-680.
- 2) Ramos S., Lucio A. Safety on Punching of Prestressed Flat Slabs / fib – Proceeding of 2nd International Congress – Naples, 2000 – p. p 17-27.
- 3) EN 1992: Eurocode 2 – Design of concrete structures –Part 1-1: General rules and rules for buildings. European Committee for standardization, Brussels.
- 4) *fib* ModelCode for Concrete Structures 2010, International Federation for Structural Concrete (fib), Lausanne, Switzerland, 2010
- 5) Тур В.В. К расчету на продавливание плоских пост-напряженных плит перекрытий / МГСУ, Сборник научных трудов – М., 2011 – с. 51-53.
- 6) Tur V. Nadolski V. Belarusian national annex to eurocode 3: basic variables formulation for the partial factors calibration, Modern Engineering 1/2016