

Wiesław Tarczyński*, Ryszard Kopka*

SIGNAL PROPAGATION IN MULTI-WIRE CABLES

ABSTRACT

The article presents the analysis of the influence of the pulses propagating in the wires of a multi-wire cables. Special attention was drawn to the process of pulses inducing in the wires to which no pulse signal was provided. The pulses interaction occur in those sections of a cable where a change of wave impedance causing a change in the reflectance is present. The pulse interaction changes its shape and amplitude. This pulse interaction can be used to diagnose the technical condition of the electric power and telecommunication cables.

Key words:

multi-wire transmission cable, transmission line model, signal propagation, pulses interaction, cable diagnostics.

INTRODUCTION

The telecommunication and electric power multi-wire cables in which the distances between the wires are arranged in such way that the wires interact with each other in noticeable way are the coupled cables. In power engineering this type of cables occur as low, medium, and high voltage cables. They can have a structure in which all the wires are shielded by one shield or they can have no shield at all. Another form of coupled cables are overhead lines with bare wires or with insulated wires covered with one shared layer of insulation, so-called insulated overhead lines.

* Opole University of Technology, Faculty of Electrical Engineering, Automatic Control and Informatics, Prószkowska 76 Str., 45-758 Opole, Poland; e-mail: {w.tarczynski; r.kopka}@po.opole.pl

The telecommunication coupled cables have somewhat different construction than the electrical power ones. They mostly comprise of parallel pairs or twisted pairs of wires creating so-called twisted-pair cables. A minimum number of wires in the cable is two and a maximum can even reach few hundreds. All of the wires can be shielded by one shield or individual pairs can be shielded separately. In the telecommunication cables, the interaction of wires has to be considered as the interaction of pairs with each other. This interaction depends on the arrangement of pairs against one another and will, of course, decrease with increasing distance between them [3].

However, in some cases the interaction between signals in different wires, can be a desired phenomenon. One of the possible applications, that definitely is positive, is fault locations with the usage of the wide-spectrum signals, e.g. impulse signals [10]. This allows to faults localisation also in wires and insulating material.

There are different types of cable faults, e.g. metallic connection, leakage conductance of the insulation to the shield, connection and leakage between wires, shield faults (for the cables with the shield), faults of the external insulation. The simple pulse method based on emitting a testing pulse and measuring the time of its propagation from the beginning of the cable to the place of damage and back, does not allow to locate all type of the faults that can be found in real life. This especially relates to the multiple faults (located in different places) in the multi-wire cables [8, 10].

CONSTRUCTION OF A THREE-WIRE COUPLED CABLE

Special kind of multi-wire coupled lines is the three-wire cable, in which three separate wires are covered by one shared shield. Such configuration of wires is used in electric power cable, mainly of medium or low voltage.

In cables with coupled wires, the wires interact with each other through the electrical and magnetic field. Considering the phenomenon characterise the signal propagation in the long cable, one can receive an equivalent circuit of the section of the unit length as presented in figure 1 [1], [2], [4], [5], [10].

The losses of signals in the wires were modelled with the longitudinal resistance R_{oj} , the inductance of individual wires — with the inductance L_{oj} , the capacity between the wires — with the capacity C_{mj} , the capacity of the wire against the shield — with the capacity C_{oj} , the inductance between the wires — with the mutual

inductance L_{mj} , the leakage of the wire insulation to the shield — with the conductance G_{oj} , and the leakage of the insulation between the wires — with the conductance G_{mj} . Symmetrical structure of the cable was assumed what means that the wave impedance of each wire against the shield is the same and of the wires against one another is also the same [10].

It is worth noting however, that the cable model does not take into consideration the influence of the harmonics of the signal on the values of individual elements. Another assumption was that the shield is a perfect frame of reference, i.e. that it has zero longitudinal resistance and zero inductance. However, in real world, the shield also comprises a system of distributed constants for the wires. Such simplifications result in differences in shape and amplitude between pulse propagation in the cable obtained in the simulation and the measurements.

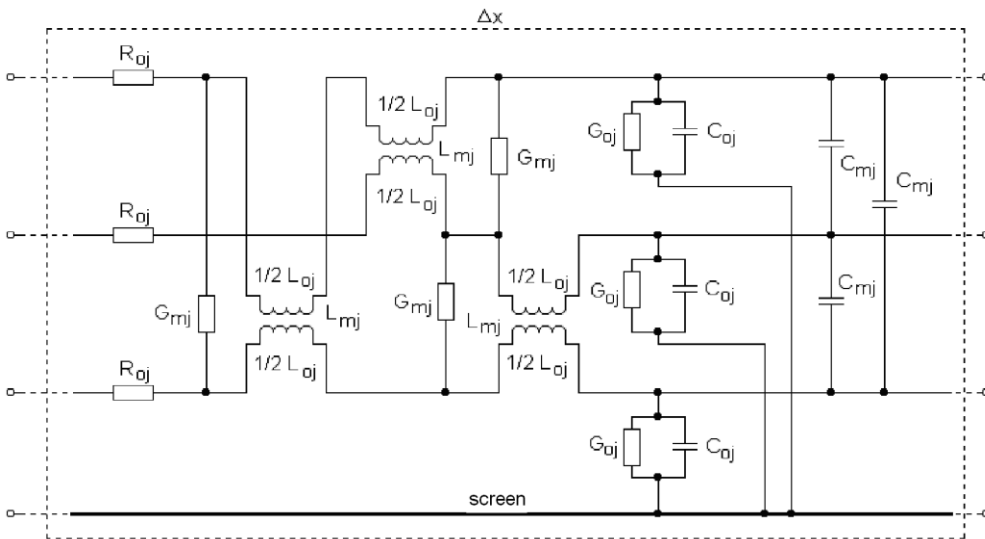

Fig. 1. The equivalent circuit of the unit section Δx of the three-wire long coupled line:
 R_{oj} — wire longitudinal resistance, L_{oj} — wire inductance, L_{mj} — wire mutual inductance,
 C_{oj} — capacity of the wire against the shield, C_{mj} — capacity between the wires, G_{oj} — conductance
of the insulation against the shield, G_{mj} — conductance of the insulation between the wires [10]

The values of the model elements were calculated based on the signals propagation characteristics for different configurations of each wires against the shield and against one another. Detailed description of the manner of calculating the value of the coupled lines model parameters for the purpose of computer simulation can be found in [10].

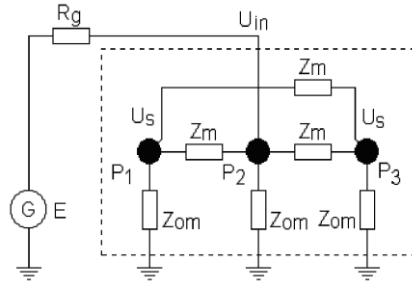

Fig. 2. The diagram of impedance interdependence between the wires, and the method of connecting the control generator G : Z_{om} — wave impedance of the cable against the shield, Z_m — wave impedance between the wires, E — signal from the generator, U_{in} , U_s — signal at the beginning of the powered wire P_2 , neighbouring wires P_1 , P_3 [10]

Nevertheless, the model represents the phenomenon of the signal interactions and the time of signal propagation, quite well [9], [10].

The impedance configuration between the wires of the three-wire cable is shown in figure 2 [9], [10] and for wire P_2 it is defined as

$$Z_{inP2} = 0,5 \frac{Z_{om}(Z_m + Z_{inS})}{Z_{om} + 0,5(Z_m + Z_{inS})}, \quad (1)$$

where $Z_{inS} = \frac{R_D Z_{om}}{R_D + Z_{om}}$

and R_D is the value of the load resistor connecting to the neighbouring wires P_1 and P_3 at the cable beginning.

Thus, the amplitude of the pulse A_{inZ} at the cable beginning in the powered wire P_2 , that will be propagating towards the end will be determined by the formula

$$A_{inZ} = E_g \frac{Z_z}{Z_z + R_g}, \quad (2)$$

where E_g is the pulse amplitude at the output of the generator G , and R_g is its internal resistance.

The amplitude of the impulses A_{inS1} and A_{inS3} induced in the neighbouring wires P_1 and P_3 , that will be propagating towards the end of the cable will be determined by the equation

$$A_{inS1} = A_{inS3} = A_{inZ} \frac{Z_{inS}}{Z_m + Z_{inS}}. \quad (3)$$

The pulses at the cable beginning in the neighbouring wires P_1 , P_3 and powered wire P_2 will be propagating towards the cable end, and will be attenuation on the whole length.

Equation (3) indicates that for the case when the resistors values R_D equal zero, thus, a shorting of the wires P_1 and P_3 to the reference level will occur, the amplitude of the pulse induced in these wires need to be zero. However, measurements indicate that in these wires, pulses created as a result of the pulses interaction from the powered wire P_2 will be induced and propagating, despite the fact of the shorting of the neighbouring wires at the cable beginning.

DESCRIPTION OF THE MEASURING CIRCUIT

The main purpose of the measurements procedures were evaluating how the interaction of wires through magnetic and electric field in the cable affects the penetration of the wide-spectrum pulse signals between the wires. Thus, experimental evaluation whether such signals interactions in the cable can be used to assess cables technical condition [8].

Laboratory studies of the pulses propagation in the chosen sections of the coupled cable were conducted for the three-wire cable in the measuring circuit shown in figure 3. The line was built from three-wire cable with one shield that covers all wires and the whole line was divided in three exactly the same sections L_1 , L_2 , L_3 , each of 100 m long.

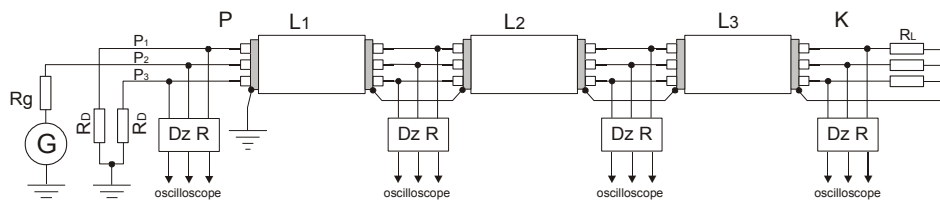

Fig. 3. The diagram of test set up for measuring pulse propagation in the three-wire coupled line: G — generator, R_g — internal resistance of the generator, R_L — load resistors of the wires at the cable end, R_D — load resistors of the neighbouring wires at the cable beginning, P_1 , P_3 — the cable's neighbouring wires, P_2 — the powered wire, L_1 , L_2 , L_3 — sections of the line, DzR — resistive divider, P , K — the beginning and the end of the cable, respectively

The testing pulses were provided by the spike generator G with the internal resistance R_g . The pulses were provided only to one wire — P_2 (so-called the powered wire). The other two wires: P_1 and P_3 (the neighbouring wires) at the beginning of the cable were loaded by the resistors R_D . At the cable end, all of the wires were loaded by the resistors R_L with the same value. The resistance value of the resistors R_L , loaded the end of the line, were selected so as to ensuring the condition of matching waves. The voltage pulses at the cable beginning and propagating in each wires and sections of the line, were recorded on the oscilloscope attached to the outputs of the resistive divider DzR.

The values of the voltage divider resistors DzR were selected so as to ensuring that their influence on the change of the line wave impedance at their connection is minimal and, at the same time, ensuring that the signal level at the output allows the observation of pulses using the oscilloscope. The output resistance of the resistive divider DzR is equal the wave impedance of the coaxial line through which the signal is send to oscilloscope. The connection places of the individual sections of the line, and connection of the voltage resistive divider DzR at these places, were made in such a way that the length of removed insulation and the shield would be below 1.5 cm.

Construction of the short connection zone ensures minimization of the adverse influence of the heterogeneity of the cable impedance creating here on the conditions of the signal propagation. The impulses of 200 ns width and amplitude E_g equal 20 V were provided to the powered wire P_2 from the generator G.

RESULTS OF THE MEASUREMENTS AND COMPUTER SIMULATION

The measurements of the pulses propagation in each wires of the coupled cable were conducted in the measuring test set up as shown in figure 3, for the case where the neighbouring wires P_1 and P_3 were opened and shorted at the beginning of the cable (point P). The measurements results are shown in figures 4 and 5, respectively. The waveforms show the results for the neighbouring wire P_1 but due to symmetrical construction of the cable they will be identical in the wire P_3 .

For the quantitative assessment of the influence of the pulse propagation in the powered wire P_2 on the value of the amplitude of the pulse propagating in the neighbouring wires P_1 and P_3 caused by self-inducing of the pulses at the cable beginning, the measurement of the propagation of the pulses in the neighbouring wires P_1 and P_3 at the distance of 100 m and 200 m from the cable beginning were

conducted, for the cases of shorted and opened the wires at the cable beginning. Then, the corresponding waveforms of the signals from the neighbouring wires P_1 and P_3 received for the shorted and opened were deducted. The differential signal this way received is a signal created as a result of an interaction of the impulse from the powered wire P_2 with the neighbouring wires P_1 and P_3 at the cable beginning. The differential signal is shown in figure 6.

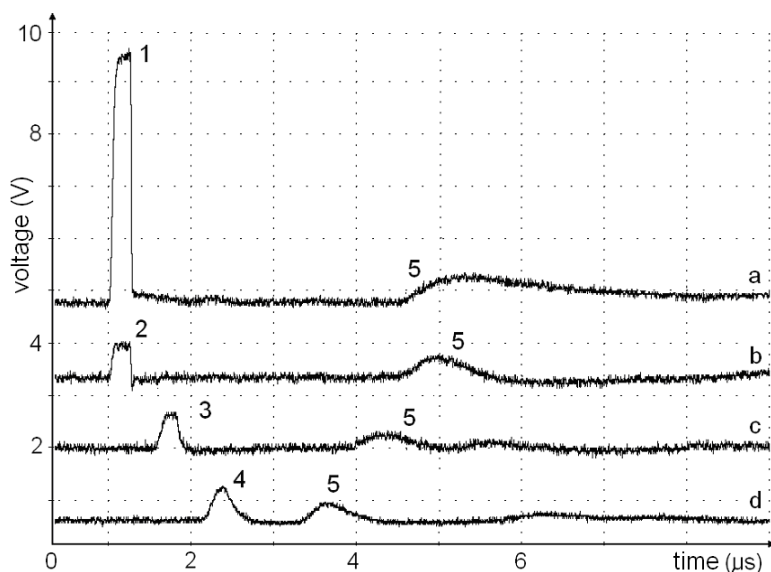

Fig. 4. Pulses propagation in the three-wire coupled cable, in individual wires, with opened the neighbouring wires P_1 and P_3 : 1 — the pulse provided to the powered wire P_2 at the cable beginning, 2, 3, 4 — pulse propagation in the neighbouring wires P_1 and P_3 at the cable beginning and at the distance of 100 m and 200 m, respectively, 5 — pulse reflected from the cable end

The measurements indicate that at the cable beginning the amplitude of pulses in the neighbouring wires P_1 and P_3 equals zero for the resistors R_D of resistance zero. However, in the same wires at the distance of several dozen meters from the cable beginning is no longer zero but it is of low value in relation to the pulse amplitude in the powered wire P_2 .

The amplitude of these pulses is low in relation to the amplitude received for the opened circuit but is not small enough to be completely ignored in the analysis of the signals propagation. The amplitude of the pulses in the neighbouring wires P_1 and P_3 reaches the maximum value, for the resistors R_D much higher than the wave impedance.

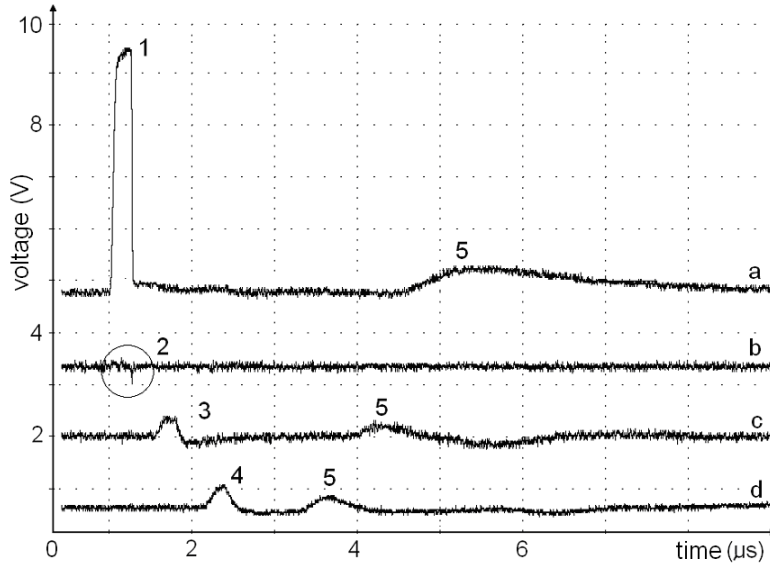

Fig. 5. Pulses propagation in the three-wire coupled cable, in individual wires, with shorted of the neighbouring wires P_1 and P_3 to the reference level at the cable beginning: 1 — the pulse generated in the powered wire P_2 at the beginning, 2, 3, 4 — pulse propagation in the neighbouring wires P_1 and P_3 at the cable beginning and at the distance of 100 m and 200 m, respectively, 5 — impulse reflected from the cable end

The reason of the pulses creation in the neighbouring wires can be the heterogeneity in the cable construction in a particular section or improper performance of the connection of the neighbouring wires to the reference level at the cable beginning. The ‘improper connection’ means such connection to the reference level that has the nonzero impedance value for all the pulse harmonics. Shape of pulses propagating in the neighbouring wires proves that they were created at the cable beginning and, while propagating, are attenuated in the same way as the pulse propagating in the powered wire.

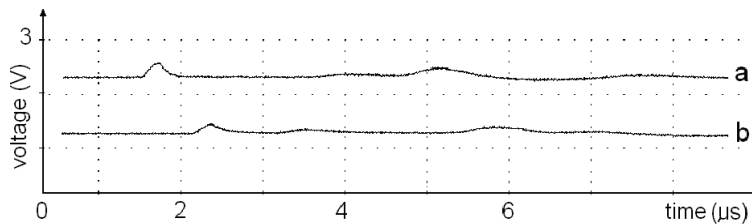

Fig. 6. Differential signals a and b obtained by subtracting the proper waveforms presented in figures 4 and 5: a — obtained by subtracting the waveforms c , b — obtained by subtracting the waveforms d

The measurements of the pulses propagation in the line in a case of shorting and opening in the powered wire at the distance of 100 m from the cable beginning was also performed. The measurements results are shown in figures 7 and 8. Connection of the powered wire P_2 to the shield as well as a break in this wire generates reflected pulse. At the same time it causes generation of pulses in the neighbouring wires P_1 and P_3 . The pulse generated during the shorting the powered wire P_2 will be propagating towards the cable beginning but the pulse induced by it in the neighbouring P_1 and P_3 will be propagating towards both, the cable end and beginning.

Its polarisation is reverse in relation to the polarisation of the pulse induced at the cable beginning and propagating towards the end. As a result, if the impulses will meet in time, the shorting in the powered wire P_2 will result in a decrease in the amplitude of the pulse in the neighbouring wires P_1 and P_3 . On the other hand, the opening will result in their increased. It can be noticed when comparing the waveforms of the signals from figures 6 and 7, and figures 6 and 8.

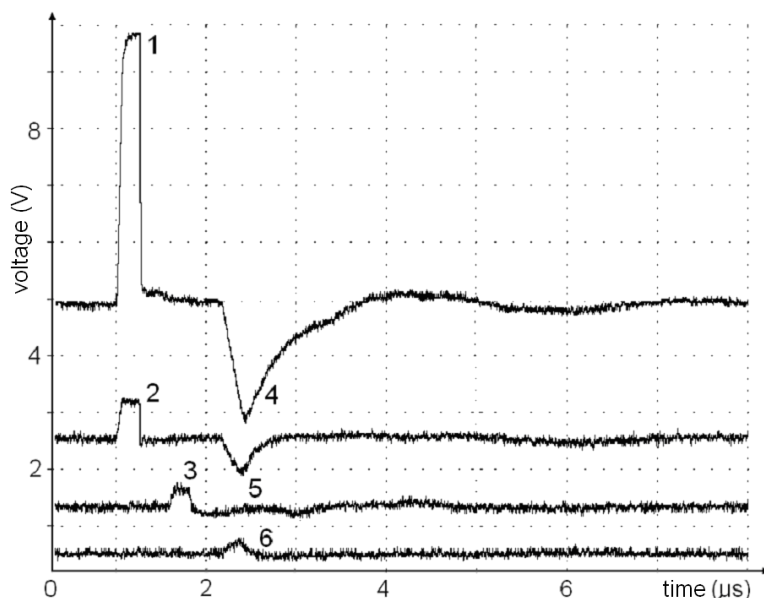

Fig. 7. Pulses propagation in the three-wire coupled line, in individual wire, with opened the neighbouring wires P_1 and P_3 at the cable beginning, and shorted in the powered wire at the distance of 100 m: 1 — the pulse sent in the powered wire P_2 at the cable beginning, 2, 3, 6 — pulses propagation in the neighbouring wires P_1 and P_3 at the cable beginning and at the distance of 100 m and 200 m, respectively, 5 — the pulse induced in the neighbouring wires P_1 and P_3 caused by the shorting in the powered wire P_2

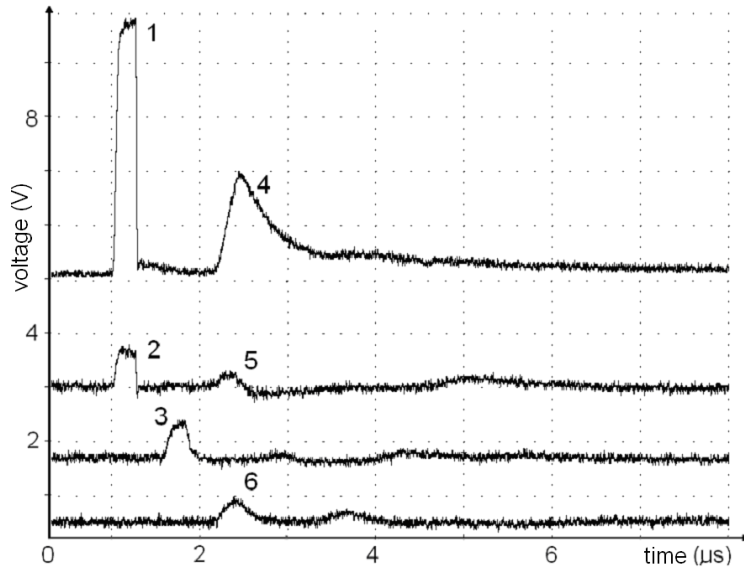

Fig. 8. Pulse propagation in the three-wire coupled line, in individual wire, with opened the neighbouring wires P_1 and P_3 at the cable beginning, and opened in the powered wire at a distance of 100 m; other markings as shown in figure 7

Beside the measurements conducted under the laboratory conditions, also computer simulation of the pulses propagation in the coupled three-wire cables was carried out. The cable model of a structure shown in figure 1 was used. The values of the model elements were calculated based on the measurements of the line wave parameters and time characteristics of the signals propagation [7], [9], [10].

The whole line of 300 m length was divided into 750 elementary sections of 40 cm each. At the cable beginning, voltage impulses of a shape similar to rectangle, with 20 V amplitude and duration of around 200 ns were delivered to the powered wire P_2 . Pulses propagation was observed in the three wires and at chosen distances from the cable beginning (e.g. 100 m, 200 m). The simulation results are shown in figure 9.

Figure 10 shows the simulation results of the pulses propagation in a case of performing shorting in the powered wire P_2 at a distance of 100 m. The simulation shows that the pulse reflected from the shorting in the powered wire P_2 is visible in the wire P_2 and the neighbouring wire P_1 .

When analysing the structure of the line model shown in figure 1 and comparing the results of the simulation shown in figures 9 and 10, and the results of measurements shown in the figures 5–7, it has to be concluded that this model simulates the propagation phenomena of the signals and their interaction quite

correctly considering quality parameters, but a big difference can be noticed, when considering quantity ones.

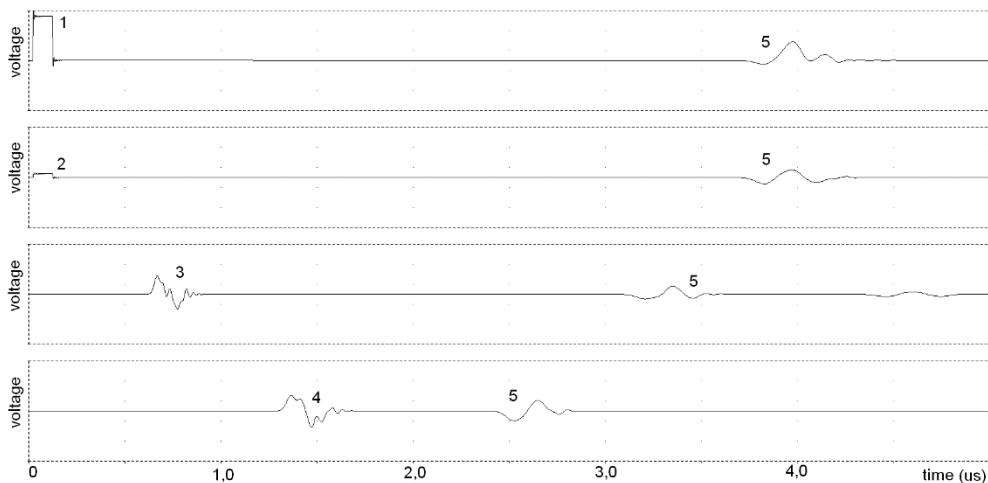

Fig. 9. Simulation results of the pulses propagations in the line with opened the neighbouring wires P_1 and P_3 at the cable beginning: 1 — the pulse in the powered wire P_2 at the cable beginning, 2 — the pulse in the neighbouring wire P_1 at the cable beginning, 3, 4 — pulses propagating in the neighbouring wire P_1 at the distance of 100 m and 200 m from the cable beginning, 5 — pulse reflected from the cable end

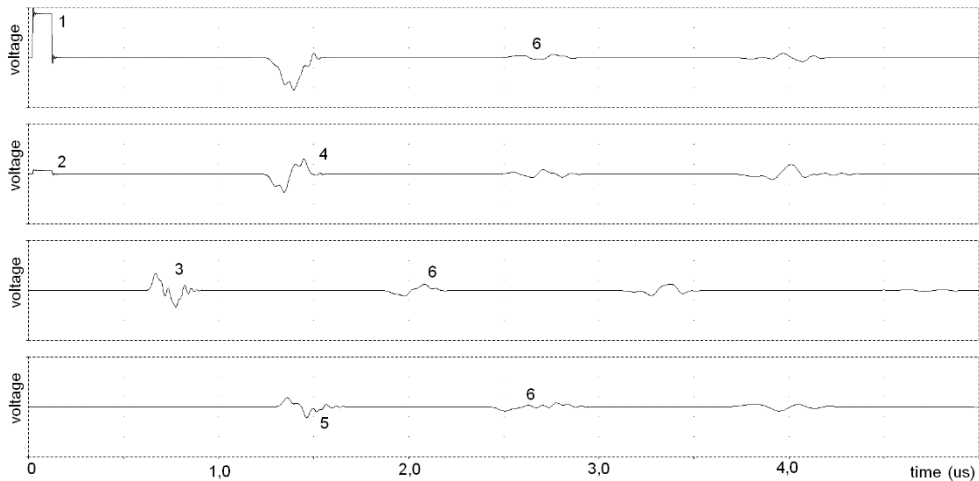

Fig. 10. Simulation results of the pulses propagation in the line with opened the neighbouring wires P_1 and P_3 at the cable beginning and shorted the powered wire P_2 at a distance of 100 m: 1 — the pulse in the powered wire P_2 at the cable beginning, 2 — the pulse in the neighbouring wire P_1 at the cable beginning, 3 — pulse in the wire P_1 at a distance of 100 m, 4 — pulse in the wire P_1 at the cable beginning caused by the shorting the wire P_2 , 5 — pulse in the wire P_1 measured at a distance of 200 m, 6 — pulses repeatedly reflected

The measurements indicate that the pulses provided to the line and those inducing in the neighbouring wires are propagating towards the end and after being reflected they go back towards the cable beginning. Due to the losses and phase lag the pulses shape and amplitude changes during their propagation. The pulses propagation observed in the process of simulation is analogous to the real system but the changes of the shape and amplitude are significantly differ.

There are a number of reasons for this discrepancy and the following can be accounted as the most important: lack of possibility to clearly determine the character of the signals interaction with each other, not including losses related to the phenomenon's typical for the transfer of wide-spectrum signals (e.g. the skin effect, the inductance of the cable and the insulator losses as the function of the frequency, etc.) in the model.

CONCLUSIONS

Measurements and computer simulation of the signals propagation in the multi-wire coupled cables indicate that, as a result of the coupling of wires, signals propagating in one wire will interact with signals propagating in the neighbouring wires. The interaction is especially visible where the change in wave impedance occurs. Considering the analysis of signals propagation and their interaction with each other, inducing pulses in the wires not being powered that are shorted with the shield at the cable beginning is significant. The studies on this phenomenon will be continued in order to find out the mechanisms of signals formation and its significance in the process of assessment of the cables technical condition, and especially in relation to values of the wave parameters.

REFERENCES

- [1] Araki K., Naito Y., *Computer-Aided Analysis of Coupled Lossy Transmission Lines*, 'Proceedings of ISCAS', 1985.
- [2] Khalaj-Amifhosseini M., *Analysis of Coupled Nonuniform Transmission Lines Through Analysis of Uncoupled Ones*, International Symposium on Antennas and propagation-ISAP, 2006, pp. 1–3.
- [3] Lao R., *The Twisted-Pair Telephone Transmission Line*, 'High Frequency Electronics', Nov., 2002, pp. 20–30.
- [4] Narahara K., *Coupled Nonlinear Transmission Line for Doubling Repetition Rate of Incident Pulse Streams*, 'Progress in Electromagnetics Research Letters', 2010, Vol. 16, pp. 69–78.

- [5] Ofranidis S. J., *Coupled lines*, 'Electromagnetic Waves & Antennas', Feb. 28, 2004, pp. 335–353.
- [6] Piątek Z., *Modelowanie linii, kabli i torów wieloprzewodowych*, Ed. Politechnika Częstochowska, seria: 'Monografie', 2007, No. 130 [*Modelling of lines, cables and path high current*, series: 'Monographs' — available in Polish].
- [7] Tarczyński W., *Conditions of pulse propagation in coupled lines*, 'Journal of the Poznan University of Technology', 2006, No. 50, pp. 19–32.
- [8] Tarczyński W., *Metody impulsowe w lokalizacji uszkodzeń w liniach elektroenergetycznych*, Ed. Politechnika Opolska, 'Studia i Monografie', 2006, Issue 191 [*Pulse methods in localization of damage in electroenergy lines* — available in Polish].
- [9] Tarczyński W., *Mutual interaction of pulses in three-conductor coupled lines*, 'Archives of Electrical Engineering', 2007, Vol. LVI, No. 1, pp. 79–87.
- [10] Wagenaars P., Wouters P. A. A. F., Wielen van der P., Steennis E. F., *Estimation of Transmission Line Parameters for Single-Core XPLE Cables*, International Conference on Condition and Diagnosis, Beijing, China, April 21–24, 2008.

PROPAGACJA SYGNAŁÓW W LINIACH WIELOPRZEWODOWYCH

STRESZCZENIE

W artykule przedstawiona jest analiza oddziaływania impulsów przemieszczających się w przewodach linii wieloprzewodowych. Zwrócono uwagę na powstawanie impulsów w przewodach, do których nie jest podawany sygnał impulsowy. Oddziaływanie impulsów występuje w miejscach linii, w których jest zmiana impedancji falowej powodująca zmianę współczynników odbicia. Oddziaływanie impulsów powoduje zmianę ich kształtu oraz amplitudy. Zjawisko oddziaływania impulsów można wykorzystać do diagnostyki stanu technicznego linii elektroenergetycznych i telekomunikacyjnych.

Słowa kluczowe:

linia długa wieloprzewodowa, model linii, propagacja sygnałów, oddziaływanie sygnałów, diagnostyka linii.