

Calculator for Electricity Supply's Unreliability Estimation (OZZEE)

Andrzej Purczyński
Higher Vocational State School in Kalisz
62-800 Kalisz, ul. Nowy Świat 4, e-mail: a.purczynski@pwsz.kalisz.pl

Ryszard Frąckowiak
Poznań University of Technology
60-965 Poznań, ul. Piotrowo 3a, e-mail: ryszard.frackowiak@put.poznan.pl

In the paper, the OZZEE software developed by the authors to compute the unreliability indicators of the electrical energy delivery to the customers and to support the reliability analysis of electric power systems is described. Basing on a given reliability structure and on the integrated elements parameters, the program can find the mean annual downtime, mean annual failure rate as well as the power supply unreliability coefficient. In analysis of the complex structures, the computation model based on the mean failure cuts (MFC) method has been applied. The assumptions applied when constructing the algorithm of computations as well as examples of the program applications in analysis of the complex grid systems have been presented.

1. Introduction

Reliability characteristics of electric power systems describe the technical and economical properties of the energy generation, transmission, distribution and receiving systems. Regarding technical aspects, the characteristics have a high impact on the adequate designing of the structure as well as on the choice of its elements. Regarding technical aspect, they are used to estimate the consumers' losses resulting from the electrical energy supply interruptions as well as the costs incurred by the energy supplier including the investments improving the energy supply's reliability and the compensations to the consumers. On the generic plot in Fig. 1, the total cost (curve 3) is a sum of the consumer's losses (curve 1) and supplier's assets (curve 2). As we can see, the costs are always resulting from the compromise reached by both the supplier and the consumer.

There are plenty of reliability coefficients that can be used to assess the system's technical conditions and to estimate costs [1]. Program of the electrical energy delivery unreliability (OZZEE) refers not but to three parameters:

- unreliability coefficient denoted as q ,
- annual average failure rate d , in 1/a units,
- annual average supply interruption duration t , resulting from the failure [in hours].

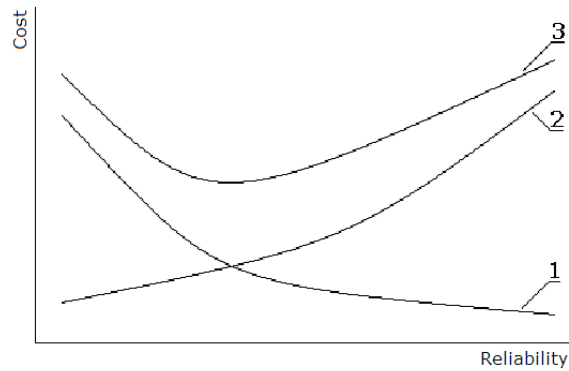

Fig. 1. Costs versus reliability -generic plot

These coefficients are mutually related by a relationship (1):

$$q = \frac{d \cdot t}{8760} \quad (1)$$

From the consumer's point of view, the *supply recovery time after failure* is the key time and is different from the *restoration time* referred also in the literature as the *failure duration time*. The restoration time includes the period from the failure –caused loss of the power supply until the repair's completion and recovery of the supply capability. The time of the energy interruption is counted from the moment the failure occurs until the supply is restored. Regarding the operation of the automatic protections and control devices, the supply interruption duration can be shorter than the restoration time.

The unreliability coefficient , q , and the reliability coefficient, p , are strictly related to each other ($p = 1 - q$); therefore, they can be used alternatively.

Electric power system includes the electric power grid with the devices for electrical energy generation or consuming connected to each other. The system's structure is determined by the system of connections between the system's elements such as lines, transformers, connectors, bus sections etc. In such a case, we use the integrated elements which can include some individual objects that form a functional entity.

The system's structure should be meant as different from the configuration that reflects the actual state of the connectors' switch-off and switch-over.

The reliability structure defines not only the way the systems elements are related to each other but also how the system's failures depends on its elements' failures. Thus, the reliability structure of the system depends not only on the system's structure but also on the system's tasks, and can differs strongly from the system's structure.

The reliability structure is the base of the calculation of the system's unreliability parameters.

In general, the reliability structure of the simple systems of energy transmission and distribution is a serial or serial parallel one [2]. In such cases, the calculations are relatively simple. However, the true systems are often more complex; there are some power supply sources as well as paths to the intake point under consideration. Therefore, the computer-aided calculation methods are applied.

2. Minimal Failure Cuts Method

The electric power system reliability computation methods can be splitted into three groups:

- analytical methods,
- simulation methods,
- combined methods.

Among analytical methods using divers mathematical tools, there are methods based on finding the *minimum worthiness paths* and *minimum disability cuts* [3]. In practice, the electrical power supply systems are of high reliability, i.e. the probability of the failure to them is low. In such cases, the more suitable method of the system's unreliability estimation is the *Minimal Failure Cuts* method.

A minimal failure cut (or minimal unreliability cut), C , is defined as a set of elements of the system's reliability structure for which:

- the system is damaged if all lumped elements of this cut are damaged,
- there is no subset of the C cut's elements with property as mentioned above.

Each system of the coherent reliability structure has a finite number of MFC. Then, the probability of the system failure $F(\tau)$ in time τ is (2):

$$F(\tau) = \sum_{i=1}^s P(C_i) - \sum_{i < j} P(C_i C_j) + (-1)^{s+1} P(C_1 \dots C_s) \quad (2)$$

where: C_i – i^{th} MFC; s – total number of MFC; $P(C_i)$ – probability of failure of the i^{th} cut; $P(C_i C_j)$ – probability of failure of the system consisted of two cuts and the cuts can have some common elements, and any element can be considered once only.

The set of all MFC determines explicitly the reliability structure of the system. Such a statement is very significant for convenient computations as, in general, not all lumped elements of the system occur in the MFC; therefore, it is sufficient to determine the reliability parameters for these elements only which enter into MFC.

Each system is disabled if and only if all elements of at least one MFC are damaged. It implies that the lumped elements of each MFC are forming the parallel structure whilst all MFC are connected in series.

Referring to relationship (2), it is possible to estimate the system's failure probability at arbitrary preset accuracy, for instance (3):

$$\sum_i P(C_i) - \sum_{i < j} P(C_i C_j) \leq F(\tau) \leq \sum_i P(C_i) \quad (3)$$

An example of calculations using the relationship (3) for a bridge structure is presented in materials 0.

Often, a proper estimation of unreliability can be achieved by considering the one-, two- or no more than three-element cuts. The error resulting from the omission of the more-than-three-element cuts is of no importance for practical results of reliability analysis [2].

For a two-parameter estimation of the serial reliability structure consisting of n single-element cuts, m two-element cuts and l three-element cuts MFC, the d and t indices are found from relationship (4):

$$d = \sum_{i=1}^n d_i^I + \sum_{j=1}^m d_j^{II} + \sum_{k=1}^l d_k^{III} \quad t \cong \frac{\sum_{i=1}^n d_i^I t_i^I + \sum_{j=1}^m d_j^{II} t_j^{II} + \sum_{k=1}^l d_k^{III} t_k^{III}}{\sum_{i=1}^n d_i^I + \sum_{j=1}^m d_j^{II} + \sum_{k=1}^l d_k^{III}} \quad (4)$$

Average interruption rate per year (średnia częstość przerw w roku) for a two-element MFC cut and an average interruption duration in the year are described by relationships (5):

$$d^{II} \cong \frac{d_1 d_2 (t_1 + t_2)}{8760} \quad t^{II} = \frac{t_1 t_2}{t_1 + t_2} \quad (5)$$

The parameters corresponding to the three-element MFC cut are given by formulas (6):

$$d^{III} \cong \frac{d_1 d_2 d_3 (t_1 t_2 + t_1 t_3 + t_2 t_3)}{8760^2} \quad t^{III} = \frac{t_1 t_2 t_3}{t_1 t_2 + t_1 t_3 + t_2 t_3} \quad (6)$$

where: i, j, k – variables described on the single-element (I), two-element (II) and three-element (III) MFC cuts, respectively, and indices 1, 2, 3 define the integrated elements composing the actual cut.

Also, the system elements' unreliability estimation depends significantly on the input data of the elements' reliability parameters. Correctness of the data is grave for obtaining the authoritative results from computations.

Reliability indices of the system elements are the results of multiannual observations and tests of the electric power system elements. In Table 1, selected data concerning the electric power system elements is specified.

System unreliability analysis with MFC method is based on simplifying assumptions:

- state of each of the system's integrated elements is described by the stationary random process,
- random processes describing the elements' states are independent processes,
- during the interruption of operation, the system elements are not damaged and are not subject to restoration.

Relationships (4) i (5) have been derived on the assumption that the interruption duration time distributions are exponential.

Table 1. Reliability indices of the electric power devices acc. to [2, 4, 5, 6]

Item	Element	Unit j	Average annual failure rate, d $\left[\frac{1}{a \cdot 100 \cdot j} \right]$	Average interruption duration, t [h]	Unreliability coefficient $q \cdot 10^{-5}$
1.	GPZ 110/15 kV	pcs	33,12	0,07	0,2647
2.	110 kV overhead line	km	1,5 (3,6)	6 (2,4)	1 (0,98)
3.	110/15 kV transformer	pcs	6 (8)	12 (6)	8,2 (5,5)
4.	110 kV circuit breaker	pcs	3 (2,1)	6 (3)	2 (0,72)
5.	110 kV isolating switch	pcs	0,8 (0,6)	4 (6)	0,4 (0,41)
6.	110 kV current transformer	pcs	0,4	10	0,46
7.	110 kV voltage transformer	pcs	0,3 (0,7)	10 (4)	0,34 (0,32)
8.	110 kV busbar (outdoor substation)	bay	4 (2,6)	4 (2,5)	1,8 (0,74)
9.	GIS circuit breaker	pcs	0,26	72	2,28
10.	GIS isolating switch	pcs	0,06	72	0,5
11.	GIS current transformer	pcs	0,006	72	0,05
12.	GIS voltage transformer	pcs	0,08	72	0,66
13.	GIS busbar	bay	0,04	72	0,33
14.	30 kV overhead line	km	6,5	13,2	9,8
15.	15 kV cable line	km	22	12	30
16.	15 kV overhead line	km	2,5	13,7	4
17.	6 kV cable line	km	24,4 (32)	59 (60)	164 (219)
18.	MV-LV transformer	pcs	4,8	29,2	16
19.	MV circuit breaker	pcs	13,2 (2,1)	5,5 (6)	8,3 (1,44)
20.	MV isolating switch	pcs	0,55	8,7	0,55
21.	MV current transformer	pcs	0,8	5	0,46
22.	MV busbar	bay	0,32	9,8	0,36
23.	0,4 kV overhead line	km	15	4	6,8
24.	0,4 kV cable line	km	6	12	8,2
25.	0,4 kV circuit breaker	pcs	1,5	3	0,5
26.	0,4 kV isolating switch	pcs	0,8	3	0,3
27.	0,4 kV open air substation	pcs	1	3	0,34

For protections, two failure states are distinguished [2]:

- lack of required action resulting in the action of the higher level protections followed by the interruption of power supply to great number of consumers,
- unnecessary action resulting from an incorrect operation of the protection.

Missing required action rate, d_b , per year is described by the missing actions coefficient, k_b , found as the quotient of the missing actions number in the year, N_b , and the number of all necessary actions in the year, N . These relationships are shown in formulas (7):

$$k_b = \frac{N_b}{N} \quad d_b = k_b \sum_{x=1}^{n-1} d_x \quad (7)$$

where: x – a variable described on the number of the outgoing feeders n , d_x – average failure rate of the x^{th} outgoing feeder.

Incorrect actions are described by the *unnecessary actions rate* d_n (8):

$$d_n = \frac{N_n}{Z} \quad (8)$$

where: N_n – number of unnecessary actions in the year, Z – number of all protections of one type installed.

Fig. 2 shows how the unreliability of protections in the substation's reliability structure is considered.

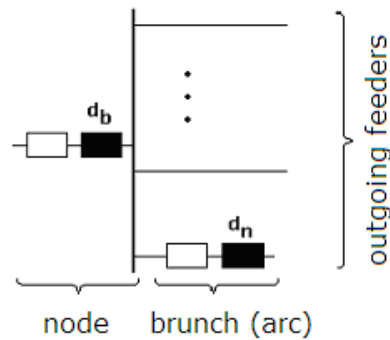

Fig. 2. Protections in the substation's reliability structure

In electric power systems, two basic types of integrated elements are distinguished:

- *node* including busbars with the selector switch disconnectors and current transformers,
- *branch (arc)* including the interrupting apparatus, lines, transformers etc.

Unreliability elements of protections are the components of both the node and the (Fig. 2). Along with other elements, they form a serial structure.

3. Basic functions of calculator

With OZZEE calculator, three parameters listed in section 1 can be estimated referring to the reliability structure scheme as well as to the data of its integrated elements. Computations can be carried out for simple structures (serial, parallel, bridge) as well as for more complex electric power distribution systems.

In Fig. 3, the initial screen of the application is shown. The first step of the work is either the selection of option in the field *Struktura pod/systemu* (*Subsystem structure*) or read in of the prepared data file from menu *Zestaw*, option *Otwórz...* (*Open...*).

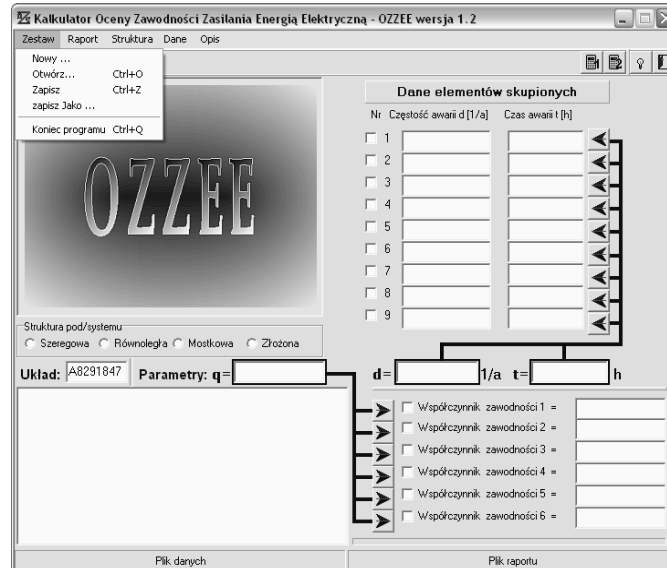

Fig. 3. Initial screen of OZZEE calculator

- Shortly, the basic properties of the application are:
- need for Windows 98/XP/Vista/7 operational system,
 - size 5 MB including description file,
 - very simple installation and removing of the application,
 - program can be started on external memories (pendrive etc.),
 - up to 100 integrated elements can be introduced in the complex structure,
 - simple structures (serial or parallel) can hold up to 9 elements,
 - for bridge-type structure, parameters for 5 elements are to be defined,
 - simple rules of the structure's construction based on the selection from the set of the ready graphical blocks,
 - structural scheme area is 26 x 16 blocks (624 x 384 px),
 - built-in suggestions which simplify the choice of reliability parameters,
 - preliminary verification of the reliability structure is carried out automatically,
 - the reports with computation results can be saved as ASCII (*txt*) file and can be easily transferred to many other applications,
 - the option of saving the structure scheme in *bmp* form is provided,
 - application is equipped with detailed description including examples of the calculator applications to diverse electric power system configurations.

In Fig. 4, a scheme of the data and results transfer in the OZZEE program is presented. Parameters are denoted as d , t , q as described in section 1. Parameter s denotes the number of units. In the program, the results and data can be entered to the data set; thus, the preliminary calculations can be carried out, especially if the integrated elements consist of some elements of the simple structure.

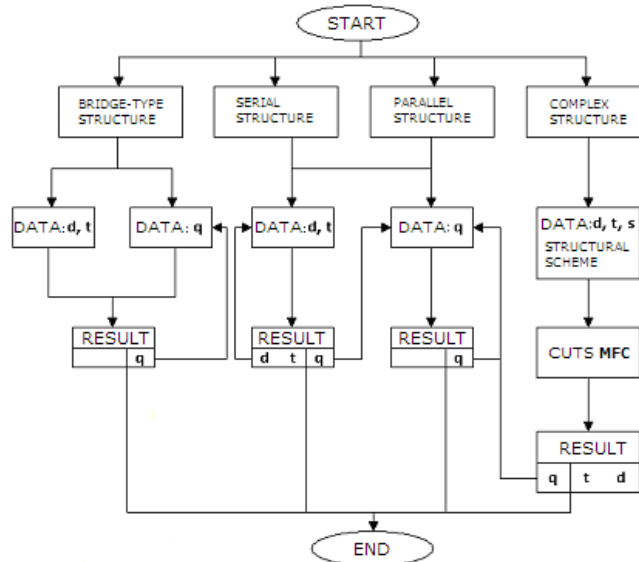

Fig. 4. Data and results transfer scheme in OZZEE application

4. OZZEE calculator – examples of applications

In his book [2], Jerzy Sozański presents the MFC method and calculation example concerning the complex electric power system. This example is solved using the OZZEE and shown in Fig. 5.

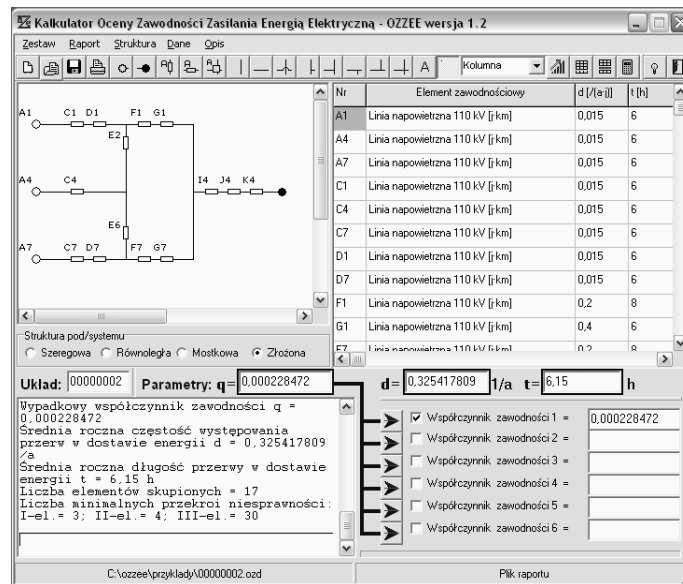

Fig. 5. Example according to [2]

In the case presented in [2], the single- and two-element cuts have been taken into account. By the OZZEE calculator, the three-element cuts (here: 30) for the analysed 110 KV network system have been additionally considered. However, in fact, the final result does not differ from that reported by Sozański ($d = 0,326$ 1/a; $t=6,14$ h). Thus, the correctness of the statement that the failure cuts with number of elements exceeding three affects insignificantly the accuracy of the found parameters of the power supply reliability has been proved.

In the complex substation systems with double bar system, sectionalized and with the bus ties, the application of graphical blocks considering the sharing of the integrated elements as well as the connectionless crossing of the lines is required to find the reliability structure. Examples of electric schemes accompanied by corresponding reliability structures compounded from the OZZEE calculator's graphical blocks are shown in Fig. 6 a,b.

Power sources are denoted A1, A5 and A2, A7. The intake points are denoted H5 and J4, respectively. Integrated elements F1, F5, C4, H2 and H6 incorporate the entire bus sections with disconnectors connected to them; therefore, it was not shown separately on the electric schemes.

a)

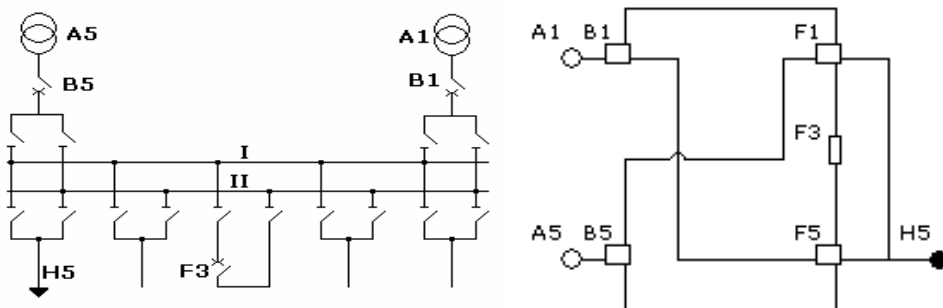

b)

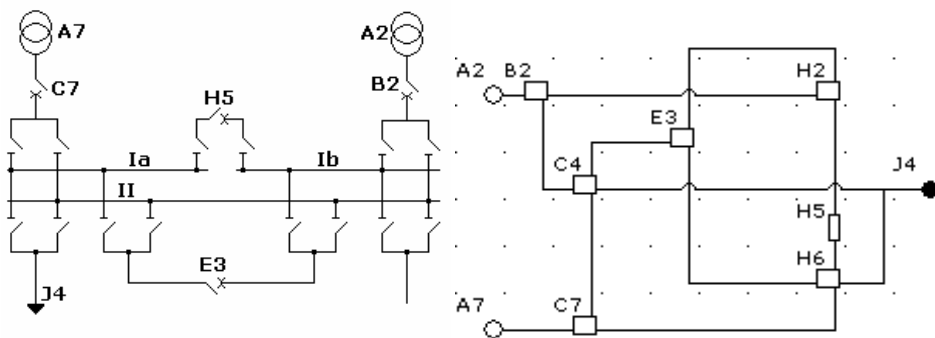

Fig. 6. Two-substation systems and corresponding reliability structures plotted by OZZEE program

In Fig. 6b, the dotted raster for the reliability structure has been saved. The raster can be removed by selecting a proper option from the application menu; however, it simplifies the layout of elements in the plotting area.

The calculator enters automatically the symbols of integrated elements on the structure's drawing, and indicators corresponding to them can be either entered from the keyboard or selected from the list attached to the program. The case of elements denoted by symbols E3 and A4 is shown in Fig. 7. Using the $\boxed{-+}$ keys, the recording of parameters can be attached (key "+") or removed (key "-") from the list of indicators.

After having entered data and having completed the calculations, one can analyze the results and browsing the report. In Fig.8, a report related to the example of the complex structure presented above is presented.

In the final part of report, all MFC cuts found in the actual structure are displayed. Such display is omitted when the option *Minimalne Przekroje Zawadności* (*Minimal Failure Cuts*) within the menu *Raport (Report)* is not marked.

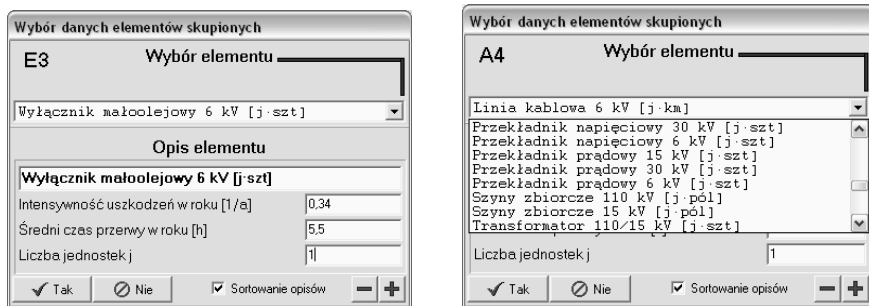

Fig. 7. Data selection / entering window

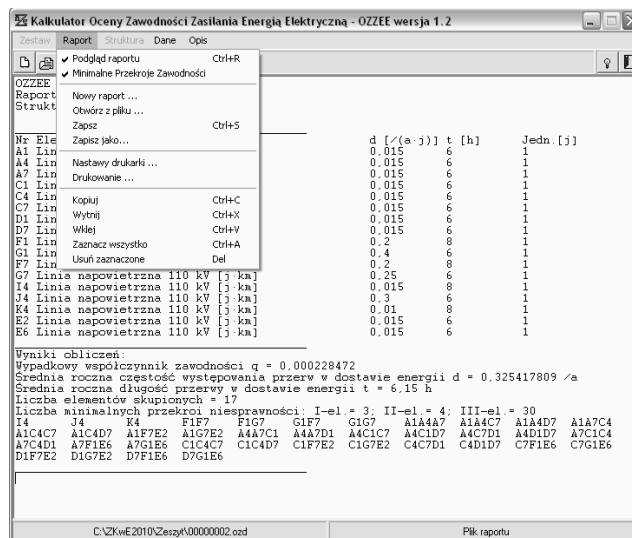

Fig. 8. Report window

5. Final remarks

The OZZEE calculator is a small application supporting the calculations of the basic reliability parameters for the transmission and distribution electric power systems. It gives opportunity to estimate the important parameters from the point of view of the reliability of electrical energy supply to consumers.

Parameters' estimation accuracy depends mostly on the input indices determined for the reliability structure's components referring to many years of observations of the elements failures and to statistical research.

Basic assumptions in the method are:

- independence between the integrated elements failures,
- constant intensity of the integrated elements failures,
- separation of damages in the failure cuts.

The completed calculations indicate that, in practice, the impact of the multi-element MFC cuts on the reliability parameters estimation significantly decreases.

Due to the Minimal Failure Cuts method applied in the OZZEE calculator, the analysis of relatively complex reliability structures such as substation systems with the multi-circuit busbars as well as with the switchable and bypass busbars can be carried out.

References

- [1] Paska J., *Niezawodność systemów elektroenergetycznych (Electric power system reliability)*, Oficyna Wydawnicza, Politechniki Warszawskiej, Warszawa 2005.
- [2] Sozański J., *Niezawodność i jakość pracy systemu elektroenergetycznego (Electric power system reliability and operation quality)*, WNT, Warszawa 1990.
- [3] Karpiński J., Firkowicz Sz., *Zasady profilaktyki obiektów technicznych (Preventive measures principles for technical objects)*, PWN Warszawa 1981.
- [4] Goc W., Mrowiec H., Urban J., *Wskazówki obliczania niezawodności przemysłowych sieci elektroenergetycznych (Indications for reliability calculations in industrial electric power systems)*, Elektroprojekt, Warszawa 1981.
- [5] Marzecki J., *Elektroenergetyczne sieci miejskie (Municipal electric power grid)*, Oficyna Wydawnicza Politechniki Warszawskiej 2006.
- [6] Stępień J.C., *Parametry niezawodnościowe głównych punktów zasilających 110/15 kV (110/15 kV Bulk power source reliability parameters)*, Mat. Konf. Aktualne Problemy w Elektroenergetyce, Jurata 2007.
- [7] Purczyński A., Frąckowiak R., *Zastosowanie metody minimalnych przekrojów do oceny zawodności zasilania (MFC method application to power supply unreliability estimation)*, Materiały ZKwE'2009, Poznań, s.109-110.