

IMO e-Navigation Implementation Strategy – Challenge for Data Modeling

M. Jonas

Federal Maritime and Hydrographic Agency, Germany

J.-H. Oltmann

Federal Waterways and Shipping Administration, Germany

ABSTRACT: The topic of e-Navigation entered the stage of IMO in 2008 already. After yearlong debates, the member states now agree about a consolidated interpretation of e-Navigation (NAV58/6, 2012). One of the principal decisions made already, is to develop the overarching consistent e-Navigation data model on all aspects related to the shipping and maritime domain at large. This so-called Common Maritime Data Structure should be built on the basis of the S-100 Framework of IHO (S-100, 2010). The basis of data modeling within the S-100 framework is the so called “IHO Geospatial Information Registry” (Registry, 2013). Although S-100 is designed to support a wider range of hydrographic data beyond ENC’s, their creators originally had no intention to expand this model to the wider scope of shipping. This paper proposes a transformation and an enhancement of the existent infrastructure towards a universal “Marine Information Registry” to host data modeling of all aspects of shipping and the maritime domain, including the modeling of non-spatial information.

1 E-NAVIGATION: CURRENT STATUS AND PLANNED PROGRESS

“e-Navigation is about getting ships safely, securely and efficiently from berth to berth in an environmentally friendly way, using globally enhanced systems for navigation, communication and related services – with the human element in focus.” (NAV58/INF.4, 2012) Based on this description, these expectations are:

- on board – harmonization of navigation systems, thereby actively engaging the mariner in the process of navigation to carry out his duties in a most efficient manner, while preventing distraction and overburdening;
- communications – providing an infrastructure which allows seamless information transfer on board ship, between ship and shore authorities and other parties with many related benefits; and

- ashore – management of Vessel Traffic Service (VTS) and related services, such as search and rescue, port and MSI services, through better provision, coordination, and exchange of comprehensive data in formats that will be more easily understood and utilized in support of vessel safety and efficiency.

A principal assumption of the e-Navigation process is to design any element in a *user driven* approach. In order to identify fitting *e-Navigation solutions*, a thorough *gap analysis* was undertaken. In it, a special tool - the *Human Element Analyzing Process (HEAP)* - was applied. HEAP is essentially a checklist for issues to consider, in particular relating to the human element, organizational and training issues. The HEAP will also be used in the next step, a *risk analysis*. In this step so-called Risk Control Options (RCOs) will identify that will be subjected to Formal

Safety Assessment (FSA) for *risk and cost-benefit analysis* of e-Navigation elements. The outcome of the analysis will be reflected in a so-called e-Navigation *Strategy Implementation Plan*. Thus, clear and traceable connections between user needs and e-Navigation solutions are established.

The following six steps are relevant to identify e-Navigation RCOs:

- 1 identify user needs that are relevant to the e-Navigation objectives;
- 2 propose relevant e-Navigation solutions that have clear origins in user needs, and that contributes to either safety or pollution prevention;
- 3 combine or redefine solutions that coincide or are similar – uphold traceability to solution origin;
- 4 develop solutions further to include infrastructural, usability and regulatory requirements;
- 5 evaluate the feasibility of the suggested solutions with regards to regulatory and infrastructural requirements; and
- 6 evaluate suggested solutions or RCOs regarding their risk reduction effectiveness – disqualify solutions with low effectiveness.

The following examples may explain what kind of e-Navigation solutions will be subject to RCO:

- *Ergonomically improved, harmonized and standardized shipboard equipment, including, amongst others,*
 - extended use of standardized and unified symbology for relevant bridge equipment,
 - standardized digital familiarization material for relevant equipment,
 - standard default settings, save/recall settings, and S-mode functionalities on relevant equipment;
 - integration and presentation of available information in nautical graphical displays including MSI, AIS, charts, radar, etc. received via communication equipment;
 - improved reliability, resilience, and integrity of bridge equipment;
 - consistent and user-friendly information management;
- *Means for standardized and automated reporting ship/shore;*
- *Improved reliability, resilience, and integrity of navigation information*
 - both for shipboard and shore-based users;
- *Improved VTS Service Portfolios and their communication to shipping;*
- *Improved and harmonized shore-based system services; and*
- *Improved access to relevant information for Search and Rescue.*

Arguably, those tools and procedures are applied on a relatively abstract level, but for that are HEAP, ROC and FSA finally good for and what will e-Navigation exactly do for the mariner?

2 DATA MODELING AS THE CORE ELEMENT OF E-NAVIGATION

One of the principal decisions made already, is to develop the overarching consistent e-Navigation data model on all navigation aspects related to the

shipping and maritime domain at large. This so-called Common Maritime Data Structure (CMDS) is considered by some the seventh of the so-called “seven pillars of e-Navigation”. The CMDS may be even the most important one because the data model provides the “cement” to the other pillars which are as follows:

- 1 the overarching architecture of e-Navigation and generalities,
- 2 shipboard equipment fit for e-Navigation,
- 3 Maritime Service Portfolios (MSPs),
- 4 Communication technologies,
- 5 Resilient PNT, and
- 6 Shore-based Infrastructure.

It was also already agreed that the CMDS should be built on the basis of the S-100 Framework of IHO. S-100 is a flexible standard which has been developed to address the limitations of the IHO S-57 standard for ENC’s in its first instance. S-100 provides the tools to create product specifications, which in turn define data content. S-100 also provides a registry that uses dynamic catalogues, which supports harmonization and enables the updating and delivery of data products.

Originally intended to cover geospatial data only, it appears that the S-100 concept could be enhanced to all aspects of shipping and the maritime domain at large, including the modeling of non-spatial information e.g. pilot requests, regulatory information and user requirements (Norway, 2011). It is hereby *proposed that the present registry concept, based on S-100 and its existent infrastructure be enhanced to and transformed into a universal “Marine Information Registry”, still being based on the S-100 framework.*

For the first time, it is proposed by this paper that the following *categories* should be used within the Marine Information Registry:

- Feature (Objects classes and Attributes)
- Exchange (data exchange)
- Portrayal (Visualization)
- Interaction (Human Element)
- Metadata(Data about data)

These categories each exhibit a distinct ontological quality, i.e. a statement/definition regarding a feature has a different ontological quality than a statement/definition regarding data exchange, and so forth. From this list of categories, all are needed to be combined to arrive at a functioning, meaningful, and complete (data) product specification, eventually. These qualities may be grouped together by calling them a **Basic Register**.

An additional **Product Specification** category would reference the above categories to that end. In the beginning of a (data) product development, the focus of attention may be assigned to feature, exchange, and portrayal, e.g.

To reflect the derivation chain from user needs to user requirements, an additional category, named **Requirements**, may be introduced.

All of the above categories would be a so-called *Register* each within the Marine Information Registry based on the S-100 Framework. Hence, the Marine Information Registry will comprise the following Registers:

- Feature,
- Exchange,
- Portrayal,
- Interaction,
- Metadata,
- Product Specification, and
- Requirements.

The Common Maritime Data Structure (CMDS) would in turn have the Marine Information Registry and its supporting infrastructure as a core.

The widened scope to all aspects of e-Navigation requires further substructures within the different categories, which are called *top-level domains*. Each of the above categories, except Metadata, should therefore be subdivided into the following *top-level domains*:

- Environment
- Infrastructure
- Units
- Operation
- Carriage

It is assumed, that those five top-level domains do principally cover all topics and themes related to marine activities. However, each of those top-level

domains has to be further detailed into entities which are subject to structuring by means of registry entries according to the S-100 notation. The following listed entities of domains are examples for first entries, however due to the principal design of a register; these lists shall expand if the scope of modeling expands step by step:

- Environment
Hydrography, Oceanography, Meteorology ...
- Infrastructure
waterways, harbor facilities, WWRNS, AIS, LRIT, communication systems (all relevant frequency bands), ...
- Units
Vessel, floating unit, group of units, offshore installation, aircraft, ...
- Operation
Voyage, Crew, ISM, Pilotage, Security, VTS, MIS, SAR, ...
- Carriage
Cargo, Passenger, Fuel, Waste, ...

The listed entities are split up further in elements:

- Vessel
Navigation, Voyage, Engine, Facilities, Spare parts, ...

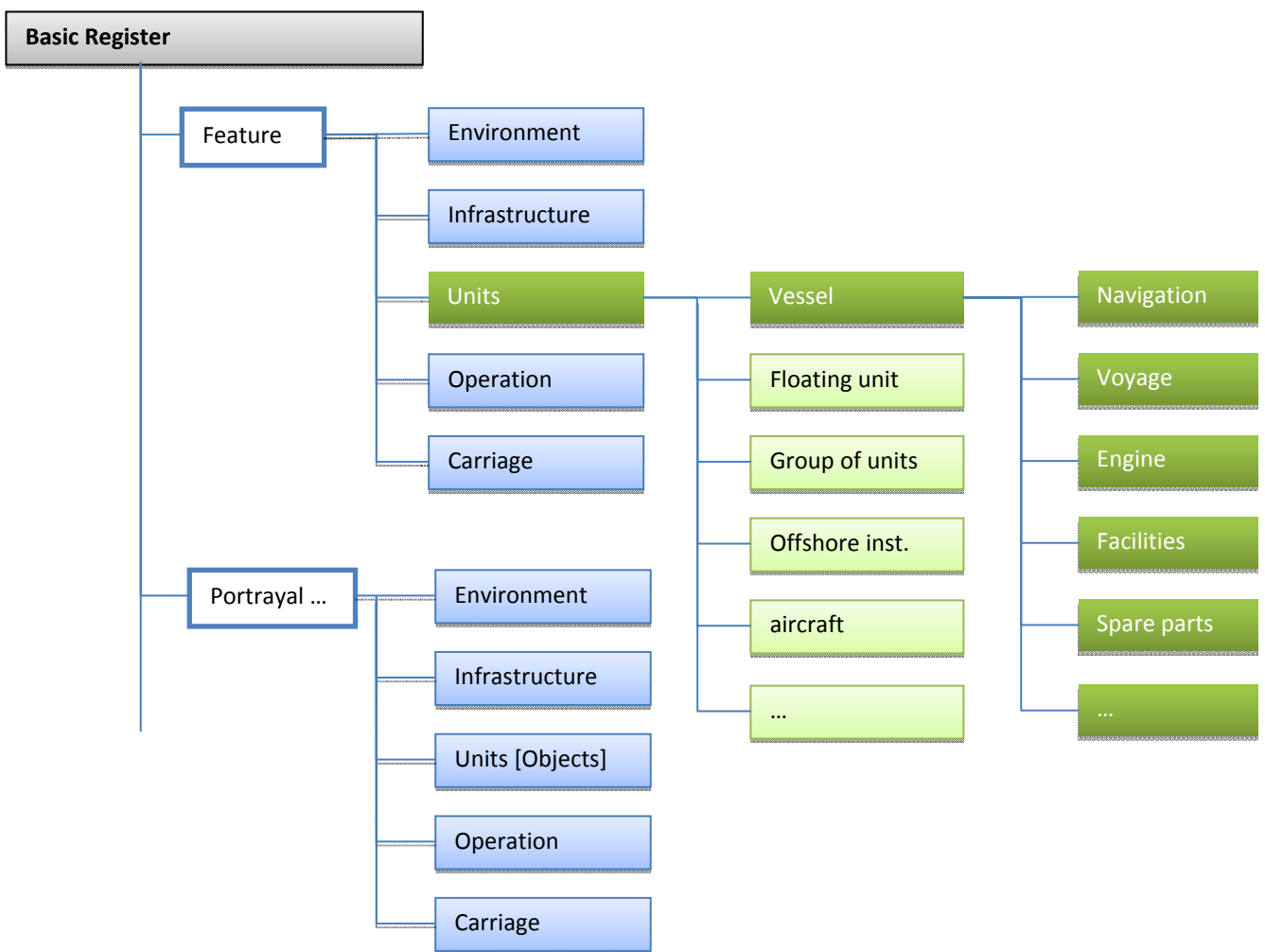

Figure 1. Example for part of the structure of the proposed future “Marine Information Registry” on the basis of S-100

The granularity and the resulting level of ramifications of the final domain entities are essentially dependent from the specific intentions of the modeling. In overlapping areas harmonization of entities should happen under the authority of a

recognized body nominated to maintain specific themes within the Marine Information Registry. A good example would be the “Hydrography” which would most likely be maintain by IHO; another one – “Oceanography” shall be under IOC. Aids to

Navigation and VTS services would most likely be maintained by IALA. And so forth. IMO has asserted governance of the e-Navigation process at large, and therefore would need to co-ordinate the assignment of those themes to relevant organizations.⁴ The entities mostly addressed, like “vessel”, might also be under central auspices of IMO. Image No 1 explains the structure of the future “Maritime Information Registry” on the basis of S-100 giving an example for the detailing of the entity “Vessel”.

2.1 Basic Register Element: Metadata

The Metadata element does not have a specific domain structure. Instead, this element of the Basic Register hosts a structured catalogue of metadata entries (similar to INSPIRE) which can be combined with the particular entries under the different domains within the Basic Register.

2.2 Product Register

The Product Register hosts Product Specifications. In contrast to the existing arrangements within the IHO GI Registry the term “Product” is of enlarged scope – “Product” in the new context is not limited to data exchange formats but is now covering more complex models for services and physical devices. There might be a need of a sub-structure according to the domain structure but along the mentioned characteristics of the products:

- Services
- Devices

The former objects hosted under Product Specifications, i.e. the IHO S-10x data exchange format family will move to “Exchange” of the Basic Register and become entities of domain “Basic Register/Exchange/Environment/Hydrography”.

2.3 Identifier

In view of the ambition to provide a structure which potentially allows absorbing any element of the marine domain, it becomes evident that unambiguity and addressability of each of those elements is essential. It is therefore proposed to introduce a system of unique identifiers on all levels of the Marine Information Registry which are ideally both human and machine readable. There is probably no need for a consistent system of identifiers across all domains. In order to adopt existing registers including their individual identifier arrangements, the following variable options could be applied as convenient to the particular domain/entity:

- alphanumerical, not meaningful
- alphanumerical, meaningful
- verbal (Camel-Case)

⁴ It should be noted, that IMO has already defined and approved a dedicated group, the so called IMO/IHO Harmonization Group on Data Modeling (HGDM), to perform this task, amongst others. The HGDM needs to be activated soon.

2.4 Interaction

Image No 2 explains the interaction between the different elements of the future Marine Information Registry as seen from the user’s perspective. The connecting arrows symbolize the hierarchical relations. There is multitude of relations and references between entities and elements within the particular basic registers which are not depicted here.

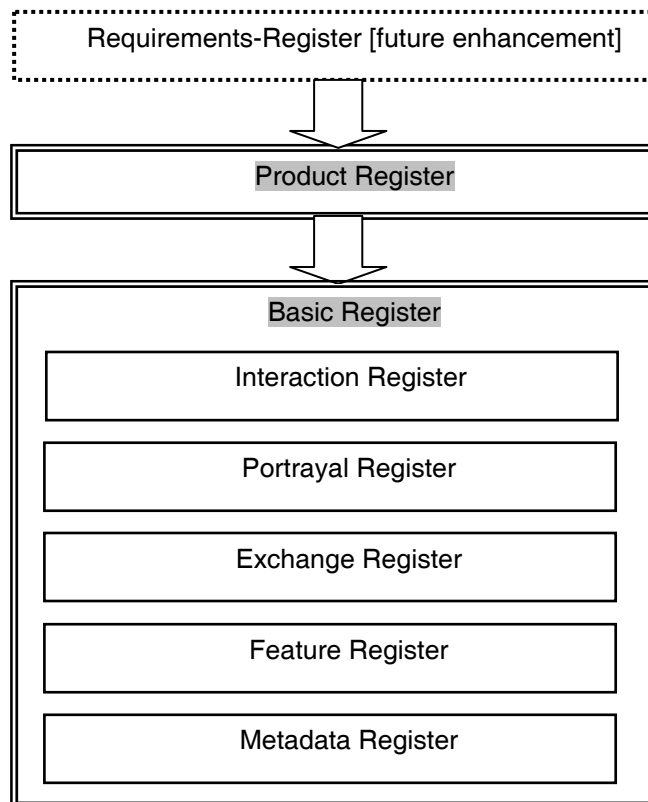

Figure 2. Interaction between the different elements of the future Marine Information Registry

3 “OWNERSHIP” VS. “STEWARDSHIP”

With the above structure of registers and domains implemented, the present S-99/S-100 concepts of “ownership” should be kept in principle but applied to individual entities and elements within the above domains. This would make “ownership” consequently a meta-data or meta-attribute of the individual entity or element definition. It would principally serve the same purpose as the present concept of “domain ownership” but be more flexible, namely if some organization or some individual (via a submitting organization) resumes responsibility for specific register entries. The concept of domains is thus also simplified by de-coupling the domain concept from “ownership”. This modification will release the domain concept from (full) domain-ownership and lowers the barriers of maritime stakeholders to associate their themes to the future Marine Information Registry. With the same intention, “ownership” under the above modification should be renamed to “stewardship” for individual entities or elements, whereas “ownership” should be reserved for the registry operators itself to expose the special role of the organization operating the appropriate IT infrastructure.

4 CONCLUSION

The ultimate goal of e-Navigation is to integrate ship borne and land based technology on a so far unseen level. The bridge between those two domains will be broadband communication technology which is about to arrive in regular commercial shipping within the next years to come. The constituting element of this integration, however, is a common maritime data model. The existing concept of the Geospatial Information Registry can be adapted to the enhanced scope of a future Marine Information Registry covering additional maritime domains by expansion, amendment and moderate rearrangement. Though the basic philosophy of the S-100 Registry prevails, virtual barriers for maritime stakeholders to associate with the Registry concept must be lowered by all means. This includes options to adopt existing register-like structures including identifier systems and stewardship for selected areas and elements of additional maritime domains in contrast to the possibly daunting overall third party ownership for a wide scientific field by potential contributors. Besides the recognized international organizations like, IMO, IHO and IALA who are currently discussing the further steps in e-Navigation, a grass root movement may take place with several stakeholders involved populating the Marine Information Registry. Such a grass root movement would truly demonstrate that e-Navigation has been understood and accepted. To allow for the orderly development of that stage of e-Navigation in accordance with the IMO defined goals and aspirations of e-Navigation, it would be required to activate the appropriate IMO instruments

already in place, namely the HGDM, to define the fundamental principles and structure of the Marine Information Registry, to assign roles and responsibilities amongst international organizations and stakeholders, and thereby facilitate the seventh pillar of e-Navigation, its "cement", namely the Common Maritime Data Structure (CDMS).

REFERENCES

- NAV58/6, I. (2012). Integration and presentation of available information in nautical graphical displays (including MSI, AIS, charts, radar, etc. received via communication equipment, Report of the e-Navigation correspondence group, March 2012. London: IMO NAV.
- NAV58/INF.4, I. (2012). Outcomes of a workshop held to demonstrate the use of the S-100 framework data standard and consider potential synergies between e-Navigation and the Marine Electronic Highway project. London: IMO.
- Norway. (2011). Feasibility Study into Using S-100 for Non Hydrographic Marine Applications. Monaco: IHO HSSC3.
- Registry, I. (January 2013). <http://www.iho.int>. called at 22. January 2013 from <http://registry.iho.int>: http://registry.iho.int/s100_gi_registry/home.php
- S-100, IHO (January 2010). IHO Universal Hydrographic Data Model. Monaco.
- S-99, IHO (January 2011). Operational Procedures for the Organization and Management of the S-100 Geospatial Information Registry .
- TC211, ISO (18. January 2013). <http://www.isotc211.org/>. called at 22. January 2013 from <http://www.isotc211.org/>.