

Carbon Footprint Analysis of Cocoa Product Indonesia Using Life Cycle Assessment Methods

Dianawati¹, Nastiti S. Indrasti^{2*}, Andes Ismayana², Indah Yuliasi², Taufik Djatna²

¹ Agroindustrial Engineering Study Program of Graduate School, IPB University, Jl. Raya Dramaga Kampus IPB Dramaga Bogor, 16680, West Java, Indonesia

² Department of Agricultural Industrial Technology, Faculty of Agricultural Engineering & Technology, IPB University, Raya Dramaga Street, Babakan, Dramaga, Bogor, 16680, Indonesia

* Corresponding author's e-mail: nastitis@apps.ipb.ac.id

ABSTRACT

The production of cocoa beans in Indonesia into chocolate and other cocoa-derived products produces emissions that pollute the environment. This research aimed to calculate the carbon footprint of the cocoa agroindustry using the Life Cycle Assessment approach in Lampung, Indonesia. The LCA under study is within the scope of Cradle to Grave, starting from nurseries_cocoa plantations_dry cocoa beans_chocolate production_retail, and consumers with emission function units per 1 kg of product. The method refers to the ISO 14040:2006 life cycle assessment standard, with the stages of determining objectives and scope, inventory analysis, impact assessment, and interpretation of recommendations. Primary data was analyzed using Simapro 9.4.0.2 Software. Secondary data was collected through a literature study. Data analysis shows the highest environmental impact after normalization resulting from four activities: packaging, transportation from industry to marketing office, and transportation from marketing office to retail. The highest environmental impact is generated by industrial activities, with a total emission of $2.57E^{-10}$ per kg of dark chocolate. In this study, GWP 100a emissions from cocoa agroforestry and agroindustry activities within the scope of the Cradle to Grave study were $7.31E^{+01}$ kg CO_{2-eq} per kg dark chocolate. In addition, selecting the type of packaging is an indicator that must be considered. Using a combination of aluminum foil, paper, and cardboard as packaging causes the second highest emission in the packaging sub-process after transportation from industry to marketing office in industrial activities. It is the 4th highest of all activities. One of the reasons for the high emissions produced in the final product or cocoa consumed by consumers is no longer in doubt. On the basis of normalization activities, the highest environmental impacts were generated by industrial activities, with a total emission of $2.57E^{-10}$. The use of packaging in packaging and fuel activities in transportation from industry to marketing office activities, industrial activities also use quite a large amount of electrical energy, namely 421.91 kWh. Recommendations for improvement can be identified to reduce the GHG impact and increase energy efficiency. Energy-saving sustainable methods constitute a challenge for the cocoa agroindustry because they positively impact the reduction of the global warming potential.

Keywords: carbon footprint; cocoa product; emissions; global warming potential; life cycle assessment.

INTRODUCTION

The carbon footprint measures the level of GHG emissions resulting from the activities of living things (Frachetti & Apul, 2013). The activities of living things on earth, including the cocoa agroindustry, affect greenhouse gases (GHG) by increasing or decreasing the number of greenhouse gases in the atmosphere. A carbon footprint

measurement as CO₂ equivalent GHG emissions (CO_{2-eq}) consists of CO₂, CH₄, and NO₂ emissions (Ramachandra & Mahapatra, 2015).

The cocoa agroindustry sector is responsible for the carbon dioxide emissions related to applying fertilizers, plant maintenance processes, production processes, plantation fieldwork operations, machinery supply, and various other minor sources. The value of the carbon footprint can be

reduced by using renewable resources and more efficient production practices (Desjardins et al., 2020). The carbon footprint of chocolate products is measured over their lifetime, from raw material extraction and direct production to their use and final reuse, recycling, or disposal (Gao et al., 2014). As part of the cocoa supply chain results, Dark chocolate products include cocoa plantations, harvesting, splitting of cocoa pods/pods to extract fruit seeds, fermentation, drying cocoa beans, shipping to the chocolate industry, distribution, and retail until the product reaches the consumer. In its activities, processes in the cocoa agroindustry supply chain involve the extraction and exploitation of natural resources that negatively impact the environment (Notarnicola et al., 2015), such as biodiversity, loss of soil, land degradation, GHG emissions, water pollution, and solid waste production (Renzulli et al., 2015). The cocoa agroindustry supply chain guarantees that chocolate products produced from cocoa plantations and processed at factories can be obtained by consumers properly (Beamon, 1998). The supply chain includes producers, suppliers, transporters, warehouses, retailers, and consumers (Chopra & Meindl, 2013).

Environmental impact calculations can be done using the life cycle assessment (LCA) method (Burman et al., 2018). LCA is a comprehensive and quantitative method for analyzing the environmental impacts of a product or service

along the product system chain (ISO, 2016). Carbon footprint can be part of measurement (LCA), focusing on GWP (Weidema et al., 2008). LCA approaches have been developed for a wide range of agricultural products. However, the study of the carbon footprint of Indonesian chocolate products using the LCA approach still needs to be completed. (Wiloso et al., 2019) stated that only a few published LCA studies focus on the final product, consumer goods, with the majority focusing on intermediary products. Until now, studies on chocolate LCA have been dominated by products from other countries, such as chocolate LCA in Ghana (Ntiamoah & Afrane, 2009), Switzerland (Büsser & Jungbluth, 2009), and Italy (Recanati et al., 2018). Cocoa products related to LCA include explaining social economy (Sharaai et al., 2020) and comparing LCA between dark, milk, and white chocolate (Bianchi et al., 2021a). Table 1 shows a study covering several countries' cradle_to_gate categories of chocolate products.

The carbon footprint analysis in this study uses LCA calculations for dark chocolate products with cradle-to-grave limits. Most studies in Indonesia that use LCA calculations with a cradle-to-gate scope have been carried out on palm oil products (Suprihatin et al., 2015) (Siregar et al., 2015), sago (Yusuf et al., 2019), arabica coffee (Diyarma et al., 2019) (Pramulya et al., 2022) and sugar cane (Gunawan et al., 2019). This study considers the category of impact on GWP scope

Table 1. Cradle-to-gate categories of chocolate products from several countries

Reference	Country	Product
(Ntiamoah & Afrane, 2009)	Ghana	Chocolate bar
(Büsser & Jungbluth, 2009)	Switzerland	Chocolate packed in aluminum foil and
(Recanati et al., 2018)	Italy	Dark chocolate
(Sharaai et al., 2020)	Malaysia	Cocoa production
(Bianchi et al., 2021a)	Italy	LCA between dark, milk, and white chocolate
This study	Indonesia	Dark chocolate

Table 2. The cradle-to-gate category and the impact of the LCA study on plantation products in Indonesia

Author	Boundaries	Product of plantation	Impact categories
(Siregar et al., 2015)	Cradle-to-gate	Palm oil	GWP
(Suprihatin et al., 2015)	Cradle-to-gate	Jatropa	GWP
(Yusuf et al., 2019),	Cradle-to-gate	Sago	GWP
(Diyarma et al. 2019)	Cradle-to-gate	Arabica coffee	GWP
(Gunawan et al. 2019)	Cradle-to-gate	Sugarcane	GWP
(Pramulya et al. 2022)	Cradle-to-gate	Gayo arabica coffee green bean	GWP
This study	Cradle-to-grave	Cocoa (Dark Chocolate)	GWP

Note: GWP – global warming potential.

cradle to grave. Table 2 shows a study in Indonesia with the same impact as the LCA method of plantation crop products.

The production of Lampung Chocolate is processed from dry cocoa beans, which are sourced from the cultivation of cocoa farmers who partner with agroindustry. Raw materials are transported from partner farmers to chocolate factories, an average of 137 km away. The production process is carried out on the bean-to-bar principle, where chocolate products are processed from the beans directly into the chocolate without separating the cocoa butter process.

The magnitude of the environmental impact of Indonesian cocoa needs to be known as a basis for recommendations for increasing environmental performance or reducing environmental impacts, especially GHGs. This study aimed to analyze the carbon footprint of the cocoa agroindustry using a Life Cycle Assessment approach in Lampung Province.

MATERIALS AND METHODS

This research relies on primary and secondary data. Direct observation and interviews with workers or industry experts were used to collect primary data. Observations were made to determine the energy used and the emissions produced at the chocolate bar processing stage. The primary data comes from observing the processing of chocolate bars in one of the cocoa agroindustries in Bandar Lampung. The method refers to the ISO 14040:2006 standard through a life cycle assessment approach, with the following stages: defining goals and scope, inventory analysis,

impact assessment, and interpretation of recommendations. Primary data was analyzed using Simapro 9.4.0.2 Software. Secondary data was collected through a literature study. Figure 1 illustrates the framework for LCA stages based on ISO/SNI 14044:2016 (ISO, 2016).

Goal and scope definition

The first step in an LCA work plan is determining the objectives and scope. The research aimed to observe the process stages of a product that has an environmental impact (Curran, 2017) from raw materials to final consumption (cradle-to-grave) (Klopffer & Grahl, 2014). This LCA study used one kg of dark chocolate as the function unit. LCI and LCIA data were obtained through data processing using the simaPro 9.4.0.2 device.

Life cycle inventory (LCI)

Inventory research, specifically identified input-output in product process stages (Cucurachi et al., 2019). Inputs include raw materials and energy resources, while outputs include primary products, by-products, emissions, and waste. Identify completed inputs, processes, and outputs were followed by quantitative calculation. Raw material and auxiliary material input, energy balance, equipment data, mass balance, electricity data, water, and fuel requirements are all examples of input data. In turn, output data include: mass balances of finished products, by-products, solid waste, liquid waste, toxic and hazardous waste. Input-output data was obtained from direct observation of the cocoa agroindustry in Lampung, and plantation data came from farmer observations and literature studies.

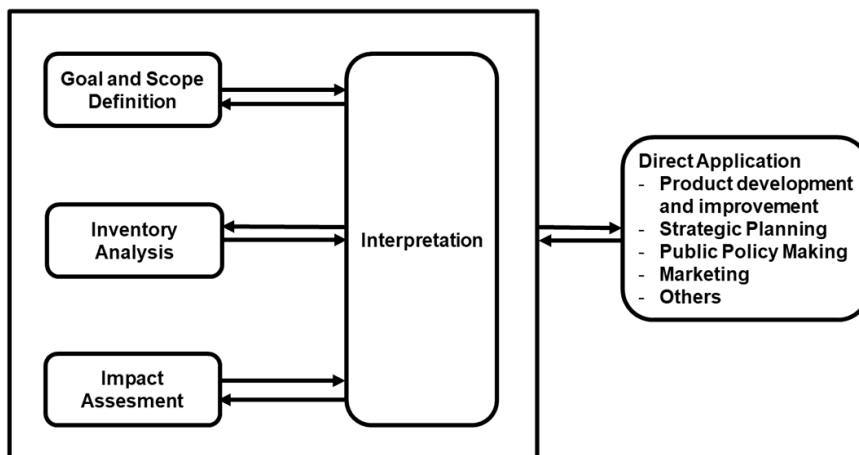

Figure 1. Framework LCA stage

Life cycle impact assessment (LCIA)

The environmental impact of the inventory life cycle analysis is assessed through impact analysis (Hauschild & Huijbregts, 2015). Greenhouse gases (GHG) are analyzed as an environmental impact contributing to global warming. GHG emissions are represented in the Global Warming Potential (GWP 100a) (Costa et al., 2021), which is the amount of CO₂ gas output and energy inputs in the life cycle of chocolate.

Interpretation and recommendation

The outcomes of the LCI and LCIA stages should be interpreted in light of the study’s objectives and scope. Inferences were drawn from the resultant hotspots during the interpretation step, notably the stages with the highest impact categories that played the most significant contribution. Improvement scenarios were developed, and the impact decrease was assessed. The fourth stage of the LCA is to interpret the inventory and impact analysis results. This phase aims to interpret data from LCI and LCIA studies into several study results for decision-making and policy. The hotspots or process stages that have the most significant impact on the impact are identified and interpreted. These hotspots are a concern for implementing improvement strategies to reduce impact and increase energy efficiency.

RESULTS AND DISCUSSION

The Indonesian chocolate life cycle assessment (LCA) approach identifies the process stages that become hotspots and provides recommendations for improvement to realize sustainable and environmentally friendly cocoa agroindustry – Greenhouse Gas Impact to measure the carbon footprint of chocolate products as GHG emissions. The scope observed in this study is cradle-to-grave chocolate products, starting from nurseries _ cocoa plantations _ dry cocoa beans _ chocolate production _ retail, and consumers. Assuming a productive tree for 16 years (Beckett, 2000), cocoa plants generally start producing 2.5–3 years after planting. The gain in cocoa fruit production in the first year is usually tiny, but as the age of the cocoa plant grows, the production of cocoa pods will also continue to increase (Edoh Adabe & Ngo-Samnack, 2014). One cocoa pod produces 30–50 seeds (Afoakwa, 2014). The scope of this study is limited to farmers in Lampung province, agroindustry in Bandar Lampung, and consumers in Jakarta, Indonesia. In this study, the functional unit was 1 kg of dark chocolate. The value chain of the „object” to be assessed will be illustrated in Figure 2.

Assumptions are conjectures that are accepted as a basis and as a basis for thinking because they are considered correct. They can be conjectures, estimates, and predictions, of course, obtained based on literature studies. Several technical assumptions are used in this study (Table 3).

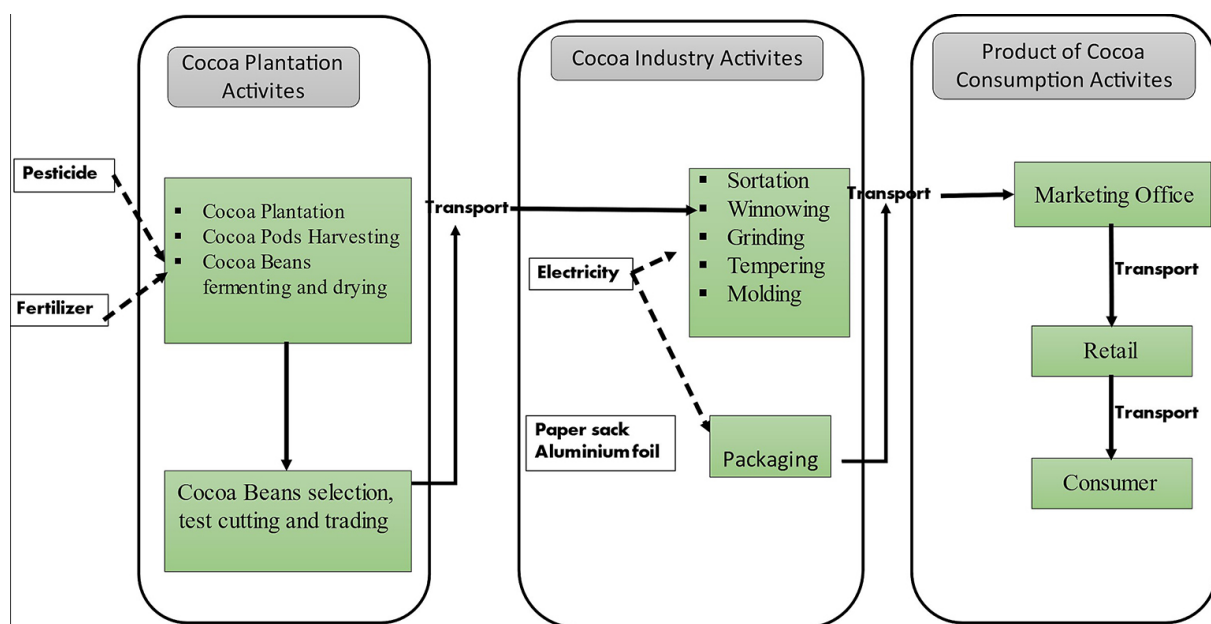

Figure 2. Cocoa Supply chain- from farmer to Indonesian consumer Chocolate (Source: UNCTAD, 2015)

Table 3. Assumptions in the study of LCA agroforestry and cocoa agroindustry

The assumptions	Unit	Value
Cocoa plant age in one cycle	Years	20.00
Number of cocoa trees per hectare	Trees/ha	39.00
Number of cocoa seeds per hectare	Pcs/ha	482.00
Cocoa crop productivity per hectare (age 5–15 years)	kg/ha	509.85
Cocoa crop productivity per hectare (age 16–20 years)	kg/ha	339.90
Percentage of cocoa beans per cocoa berries	%	27.00
The yield of dried cocoa beans after fermentation, drying, and sorting	%	38.50
Percentage of broken cocoa beans during fermentation, drying, and sorting	%	10.00
Distance from cocoa plantation to industry	km	150.00
Petrol consumption L300 pick up in liters	L/km	9.40
Petrol consumption L300 pick up in kilogram	kg/km	12.70
Load capacity L300 pick up	ton	2.50
Petrol engine oil change standard	km	5.000.00
Petrol engine oil capacity	L	5.00
Deformed Cocoa Beans from farmers	%	11.86
SOP fermentation	%	2.35
SOP drying	%	1.17
Epidermis	%	0.38
Loss in grinding	%	1.00
Distance from industry to retile (land route)	km	214.20
Distance from industry to retile (sea route)	km	34.00

Table 4. LCI of cocoa plantation activities

Unit process	Input/Output	Unit	Amount
Maintenance	Input		
	Cacao tree	trees	0.93
	Urea	kg	4.02
	TSP	kg	2.62
	KCl or MOP	kg	2.59
	Kieserite (MgSO ₄)	kg	0.05
	ZA	kg	8.27
	Output		
Cocoa pod	kg	15.56	
Harvesting	Input		
	Cocoa pod	kg	15.56
	Output		
	Cocoa Beans	kg	4.20
	Solid Waste	kg	11.36
Fermentation, drying, and sorting	Input		
	Cocoa beans	kg	4.20
	Output		
	Dry cocoa beans	kg	1.20
	Water vapor	kg	2.58
Broken cocoa beans	kg	0.42	
Transportation from farmer to industry	Input		
	Dry cocoa beans	kg	1.20
	Fuel	kg km	143.71
	Oli	kg km	0.14
	Output		
Dry cocoa beans	kg	1.20	

Table 5. LCI of cocoa industry activity

Unit process	Input/Output	Unit	Amount
Sortation	Input		
	Dry cocoa beans	kg	1.20
	Energy (electrical)	kWh	0.01
	Output		
	Whole cocoa beans	kg	1.06
	Broken cocoa beans	kg	0.14
	Emission		
Winnowing	Input		
	Whole cocoa beans	kg	1.06
	Energy (electrical)	kWh	0.16
	Output		
	Nib	kg	1.05
	Shell	kg	0.00
	Emission		
Grinding	Input		
	Nib	kg	1.05
	Energy (electrical)	kWh	0.06
	Output		
	Cocoa liquor	kg	1.04
	Loss	kg	0.01
	Emission		
Mixing	Input		
	Cocoa liquor	kg	1.04
	Energy (electrical)	kWh	0.20
	Output		
	Cocoa liquor	kg	1.03
	Loss	kg	0.01
	Emission		
Tempering	Input		
	Cocoa liquor	kg	1.03
	Energy (electrical)	kWh	0.05
	Output		
	Cocoa liquor	kg	1.02
	Loss	kg	0.01
	Emission		
Moulding	Input		
	Cocoa liquor	kg	1.02
	Energy (electrical)	kWh	0.16
	Output		
	Dark chocolate bar	kg	1.01
	Loss	kg	0.01
	Emission		
Packaging	Input		
	Cardboard	kg	0.12
	Aluminium foil (PET)	kg	0.20
	Paper	kg	0.20
	Dark chocolate bar	kg	1.01
	Energy (electrical)	kWh	0.26
	Output		
	Dark chocolate	kg	1.00
	Loss	kg	0.01
Transportation from industry to marketing office	Input		
	Dark chocolate bar	kg	1.01
	Fuel	kg km	173.09
	Oli	kg km	0.12
	Output		
	Dark chocolate bar	kg	1.01

Life cycle inventory

LCI analysis entails compiling and quantifying input-output data to conduct life cycle assessments within defined boundaries of research objectives (Meteyer et al., 2014). The following data must be collected input-output data for producing raw materials used to produce products (including primary or secondary materials). Table 4 shows the life cycle inventory of plantation activities.

Table 4 shows the input and output processes in cocoa plantation activities. Activities include the treatment phase, harvesting, fermentation, drying and sorting, and transporting dry seed products to the industry. Activities in the industry and the resulting input-output data become the second scope in the cocoa agroindustry phase, as shown in Table 5.

Table 6. LCI of cocoa consumption activity

Unit Process	Input/Output	Unit	Amount
Transportation from marketing office to retail	Input		
	Dark chocolate bar	kg	1.01
	Fuel	T km	0.01
	Oli	T km	0.00
	Output		
Dark chocolate bar	kg	1.01	
Consumers	Input		
	Dark chocolate bar	kg	1.01
	Output		
	Cardboard	kg	0.12
	Aluminium foil (PET)	kg	0.20
Paper	kg	0.20	

Table 5 shows the activity process in the industry, where activities include the stages of making chocolate products until they are packaged and then distributed to be sent to the marketing office.

Table 6 shows the input-output process for consuming processed cocoa products, which includes distribution activities from the marketing office to retail and ends with consumers.

Life cycle impact assessment (LCIA)

The characterization of each resource used and the emissions produced are quantitatively modeled using predetermined impact categories. The goal is to change the data on the use of resources and the resulting emissions into a predetermined impact value (CML _ Department of Industrial Ecology, 2016).

On the basis of Figure 3, they have contributed two activities in the consumer sector to the highest GWP, each of 6.93 kg CO_{2-eq}. In the industrial sector, the last two activities, packaging and transportation from industry to marketing, also contributed to high GWP, namely 6.64 and 6.92 kg CO_{2-eq}, respectively. The use of plastic polymer-type packaging is the cause of high GWP emissions in packaging and consumption activities (Bianchi et al., 2020), while the use of fossil fuels is the cause of high GWP emissions in transportation from industry to marketing and transportation from marketing office to retail activities.

According to (Ortiz-r et al., 2014), GWP 100a emissions from cocoa plantation activities

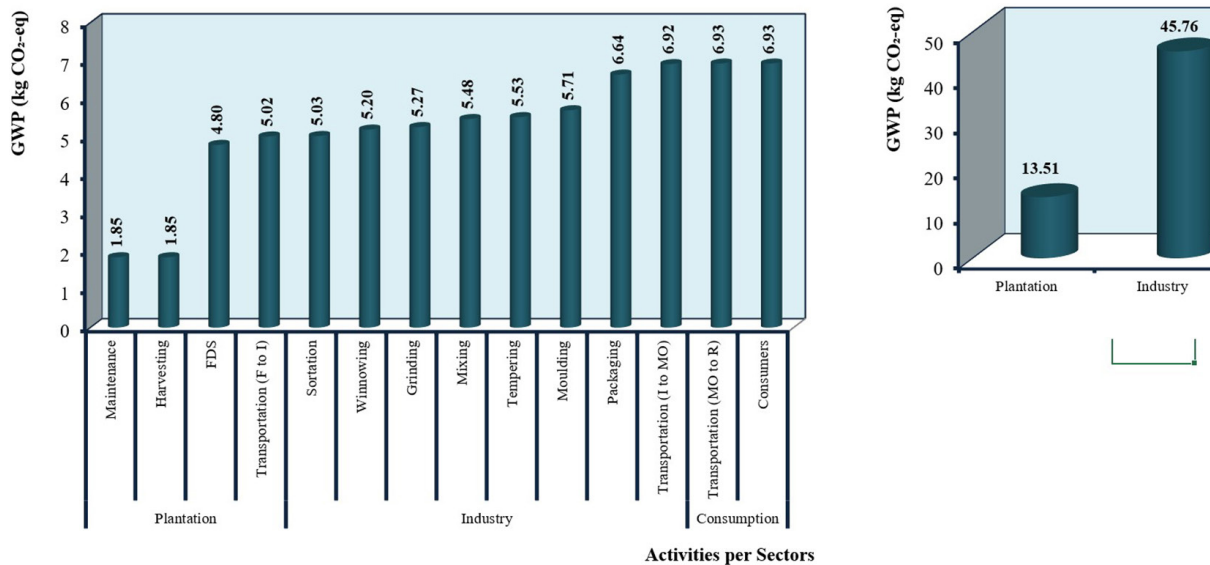

Figure 3. GWP characterization results for each activity in each sector

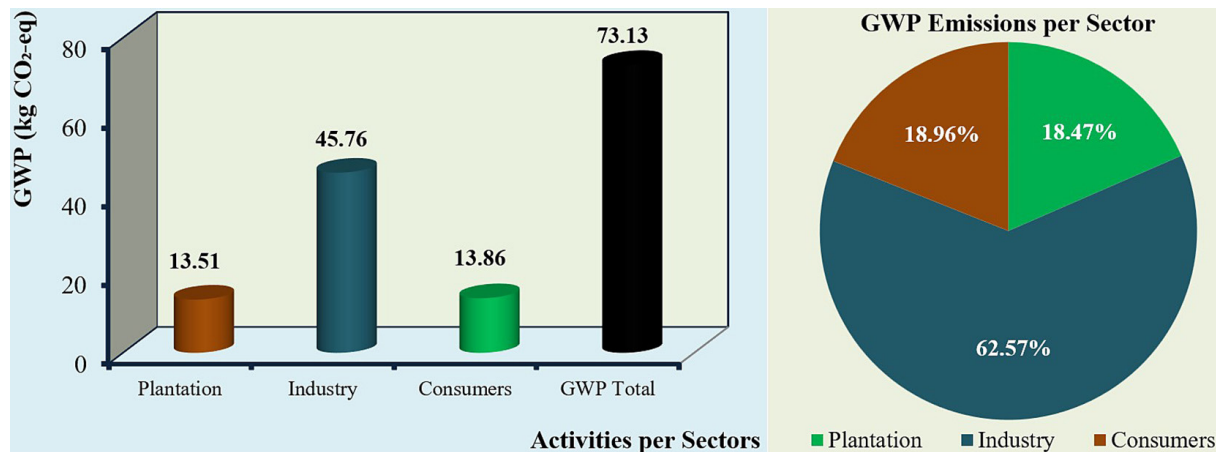

Figure 4. GWP characterization results for each sector

are lower when compared to cocoa industrial activities. In addition, according to (Bianchi et al., 2021a), the GWP 100a emissions resulting from cocoa agroforestry and agroindustry activities within the Cradle to Grave study scope show lower GWP 100a emissions per kilogram of dark chocolate when compared to milk chocolate and white chocolate. In this study, the GWP 100a emissions resulted from cocoa agroforestry and agroindustry activities in the Cradle to Grave study scope, namely 73.13 kg CO_{2-eq} per kg dark chocolate where the highest contribution was produced from the industrial sector, namely 45.76 kg CO_{2-eq} per kg of dark chocolate or about 62.57% of the total GWP emission (Figure 4). This value is lower when compared to the research results obtained by (Ortiz-R et al., 2014) and higher when compared to the research results obtained by (Bianchi et al., 2021a).

Interpretation and improvement recommendations

The selection of the packaging type is one indicator that must be considered. According to (Bianchi et al., 2021a), the polypropylene (PP) coating results are the materials with the most negligible impact in all the categories analyzed. The two combinations of aluminum foil with fiber-based materials produce greater impact than PP casings, mainly due to the production of aluminum-based materials. As a result, an aluminum layer plus cardboard is the most impactful solution across all categories. In this study, they use a combination of aluminum foil, paper, and cardboard as packaging caused emissions produced in the packaging sub-process to be the second highest

after Transportation from Industry to the Marketing Office in industrial activities and the 4th highest of all activities. Indicate one of the causes of the high emissions produced in end-products or cocoa that consumers use up.

According to Table 7, based on the assessment of the impact of chocolate production, recommendations for improvement can be identified to reduce the impact of GHGs and increase energy efficiency. Planning for energy reduction for the cocoa agroindustry is an effort that needs support, because it positively impacts the reduction of GWP potential. Energy reduction programs can be implemented in various ways, including increasing energy efficiency and producing energy from waste. All subsystems use energy in the cocoa agroindustry. As a result, energy consumption in each cocoa agroindustry unit can be optimized. Some recommendations for improvement that

Table 7. Impact category

Type of activity	Activity	Impact category	Unit
Plantation	Maintenance	1.85E+00	kg CO ₂ eq
	Harvesting	1.85E+00	
	FDS	4.80E+00	
	Transportation (F to I)	5.02E+00	
Industry	Sortation	5.03E+00	kg CO ₂ eq
	Winnowing	5.20E+00	
	Grinding	5.27E+00	
	Mixing	5.48E+00	
	Tempering	5.53E+00	
	Moulding	5.71E+00	
	Packaging	6.64E+00	
	Transportation (I to MO)	6.92E+00	

can be given include 1) Usecompost in the plantation phase, 2) Minimize the use of packaging that causes impacts, 3) Minimize the use of Electrical Energy, and 4) Develop digitalization in marketing units such as market places to reduce the impact. Minimizing packaging and efficient use of electrical energy is an effort to reduce the impact.

Analysis of the environmental impact of the cocoa agroindustry supply chain is a relevant topic with considerable consequences and, at the same time, a concern for the consumers who prefer sustainable products. In addition to environmental factors, there is an increasing demand for cocoa products, so the life cycle limit of dark chocolate proposed through the LCA approach is from the cradle to the grave. Analyses of various situations involvedifferent cocoa-producing countries. Geographical conditions and agricultural techniques have different environmental effects depending on the inputs used. Due to the everyday use of fertilizers and pesticides as well as the proximity of cocoa farms and factories, the case study on cocoa production in Ghana has little impact; however, the water consumption value is higher. Raw material production, mainly cocoa by-products, significantly impact all categories.

Furthermore, a comparison of packaging materials is proposed to analyze various options.

A single layer of PP is recommended, whereas aluminum foil, commonly used with external fiber-based packaging, has a higher environmental impact. Comparative analysis between the two allocation procedures applied to mass and energy content revealed no significant differences, highlighting the validity of the same in its application to cocoa LCA studies. In both cases, dark chocolate outperformed the other two types regarding global environmental performance. This result is also qualitatively confirmed in the case of calories as a functional unit (Bianchi et al., 2021a). Recommendations for improvement can be identified to reduce the GHG impact and increase energy efficiency. Energy-efficient sustainable methods are challenging for the cocoa agroindustry as they positively impact the reduction of potential global warming. Improving the efficiency of energy use and utilizing energy from waste are recommendations in energy reduction planning. Table 6 shows the energy potential generated from dark chocolate production in Lampung.

On the basis of Table 8, improvements to the dark chocolate production system can be carried out in various ways, including reducing energy efficiency, using water and electricity more efficiently, and minimizing waste. They reduce

Table 8. Using energy in the dark chocolate production

Parameter	Unit process	Input (MJ per kg dark chocolate bar)	Output (MJ per kg dark chocolate bar)
Plantation	Maintenance	522.7895	287.5985
	Harvesting	287.5985	287.5985
	Fermentation, drying, and sorting	105.4542	40.5999
	Transportation from farmer to industry	30.2635	30.0545
	Total in plantation	946.1058	645.8514
Industry	Sortation	30.1019	30.0545
	Winnowing	27.0600	13.1646
	Grinding	13.3713	13.1442
	Mixing	13.7154	13.0128
	Tempering	13.0496	12.8826
	Moulding	13.3415	12.7538
	Packaging	18.7175	17.7848
	Transportation from industry to marketing office	19.1507	17.6585
Total in industry	148.5079	130.4557	
Retail	Transportation from marketing office to retail	17.8679	12.5000
	Consumers	17.6585	17.6585
	Total in retail	35.5264	30.1585
Over all process	Total	1.130.1401	806.4656

energy consumption to increase economic and environmental sustainability (Mert et al., 2017). Water use efficiency is achieved by minimizing water use or recycling water and reducing the environmental impact on dark chocolate production (Mert et al., 2017). Efficient use is accomplished by reducing the amount of electricity used or utilizing environmentally friendly electricity such as solar, wind, hydropower, ocean or tidal energy, geothermal energy, and biomass (Rudenko et al., 2017). Waste is reduced by implementing clean production (Purwanto, 2021) or green technology (Ngo et al., 2016).

CONCLUSIONS

LCA of chocolate was studied in the scope of cradle to grave, starting from the cocoa plant maintenance phase with the assumption that it is a productive annual plant for up to 20 years, processing dry cocoa beans, industrial processing to chocolate consumption by consumers with a functional unit of 1 kg of dark chocolate products converted into one cycle. The environmental impact considered is the potential for CO_{2-eq} GHG emissions. In this study, the emission of GWP 100a from agroforestry and cocoa agroindustry activities in the Cradle to Grave study scope was 7.31E⁺⁰¹ kg CO_{2-eq} per kg of dark chocolate. In addition, selecting the type of packaging is an indicator that must be considered. Using a combination of aluminum foil, paper, and cardboard as packaging causes the second highest emission in the packaging sub-process after transportation from industry to marketing office in industrial activities. It is the 4th highest of all activities. One of the causes of the high emissions produced in end-products or cocoa that consumers use up is undoubted. On the basis of onnormalized activities, the highest environmental impact is generated by industrial activities, with a total emission of 2.57E⁻¹⁰. Using packaging in packaging activities and fuel in Transportation from Industry to Marketing Office activities, industrial activities also use large amounts of electricity, namely, 421.91 kWh.

Acknowledgements

The author(s) received no financial support for this article's research, authorship, and/or publication of this article.

REFERENCES

1. Afoakwa, E.O. 2014. Cocoa Production and Processing Technology. Cocoa Production and Processing Technology. <https://doi.org/10.1201/b16546>
2. Bantacut, T., Romli, M., Noor, E. 2019. Life cycle assessment of cane-sugar in Indonesian sugar mill: energy use and GHG emissions. IOP Conference Series: Materials Science and Engineering, 536(1), 12059
3. Beamon, B.M. 1998. Supply chain design and analysis: Models and methods. International Journal of Production Economics, 55(3), 281–294.
4. Beckett, S.T. 2000. The Science of Chocolate. The Science of Chocolate.
5. Bianchi, F. R., Moreschi, L., Gallo, M., Vesce, E., Del Borghi, A. 2021a. Environmental analysis along the supply chain of dark, milk and white chocolate: a life cycle comparison. International Journal of Life Cycle Assessment, 26(4), 807–821. <https://doi.org/10.1007/s11367-020-01817-6>
6. Burman, N.W., Croft, J., Engelbrecht, S., Ladenika, A.O., MacGregor, O.S., Maepa, M., Bodunrin, M. O., Harding, K.G. 2018. Review: Life-cycle assessment, water footprinting, and carbon footprinting in Portugal. International Journal of Life Cycle Assessment, 23(8), 1693–1700.
7. Büsser, S., Jungbluth, N. 2009. LCA of Chocolate Packed in Aluminium Foil Based Packaging. Pages)
8. Chopra, S., & Meindl, P. 2013. Supply Chain Management: Strategy, Planning, and Operation (Fifth Edit). Prentice Hall. <https://doi.org/10.1017/CBO9781107415324.004>
9. CML - Department of Industrial Ecology. 2016. CML-IA Characterisation Factors. Universiteit Leiden.
10. Costa, C., Wironen, M., Racette, K., & Wollenberg, E.K. 2021. Global Warming Potential*(GWP*): Understanding the implications for mitigating agricultural methane emissions.
11. Cucurachi, S., Scherer, L., Guinée, J., Tukker, A. 2019. Life Cycle Assessment of Food Systems. One Earth, 1(3), 292–297. <https://doi.org/https://doi.org/10.1016/j.oneear.2019.10.014>
12. Curran, M.A. 2017. Overview of goal and scope definition in life cycle assessment. In Goal and scope definition in life cycle assessment. Springer, 1–62.
13. Desjardins, R.L., Worth, D.E., Dyer, J.A., Vergé, X.P.C., McConkey, B.G. 2020. The carbon footprints of agricultural products in Canada. Carbon Footprints. Springer, 1–34.
14. Diyarma, I., Bantacut, T. 2019. Assessment of the environmental impact of the gayo arabica coffee production by a wet process using life cycle assessment. Acta Universitatis Cibiniensis. Series E: Food Technology, 23(1), 27–34

15. Edoh Adabe, K., Ngo-Sammick, L. 2014. Cocoa: Production and processing. CTA.
16. Franchetti, M.J., Apul, D. 2013. Carbon footprint analysis. *International Journal of Climate Change Strategies and Management*, CRC Press, 5(2). <https://doi.org/10.1108/ijccsm.2013.41405baa.010>
17. Gao, T., Liu, Q., Wang, J. 2014. A comparative study of carbon footprint and assessment standards. *International Journal of Low-Carbon Technologies*, 9(3), 237–243.
18. Hauschild, M.Z., Huijbregts, M.A.J. 2015. Introducing life cycle impact assessment. In *Life cycle impact assessment*. Springer, 1–16.
19. ISO, S. 14040. 2016. SNI ISO 14040-2016, Manajemen lingkungan—Penilaian daur hidup—Prinsip dan kerangka kerja. b
20. Klopffer, W., Grahl, B. 2014. *Life Cycle Assessment (LCA) A Guide to Best Practice*. Wiley-VCH. <https://www.ptonline.com/articles/how-to-get-better-mfi-results>
21. Mert, G., Linke, B.S., Aurich, J.C. 2017. Analyzing the Cumulative Energy Demand of Product-service Systems for Wind Turbines. *Procedia CIRP*, 214–219. <https://doi.org/10.1016/j.procir.2016.09.018>
22. Meteyer, S., Xu, X., Perry, N., Zhao, Y.F. 2014. Energy and material flow analysis of binder-jetting additive manufacturing processes. *Procedia Cirp*, 15, 19–25.
23. Mila, G., Primasari, B., Aziz, R. 2021. Application of Life Cycle Assessment (LCA) On Green Tea Product (Case Study in the X Company). *IOP Conference Series: Materials Science and Engineering*, 1041(1), 12025.
24. Ngo, H.H., Guo, W., Surampalli, R.Y., Zhang, T.C. 2016. Green technologies for sustainable water management. *Green Technologies for Sustainable Water Management*. <https://doi.org/10.1061/9780784414422>
25. Notarnicola, B., Tassielli, G., Renzulli, P. A., Lo Giudice, A. 2015. Life Cycle Assessment in the agri-food sector: an overview of its key aspects, international initiatives, certification, labelingschemes methodological issues. *Life Cycle Assessment in the Agri-Food Sector*, 1–56.
26. Ntiamoah, A., Afrane, G. 2009. Life Cycle Assessment of Chocolate Produced in Ghana.
27. Ortiz-R, O. O., Amanda, R., Gallardo, V., Rangel, J.M. 2014. Applying life cycle management of Colombian cocoa production, 34(1), 62–68.
28. Pramulya, R., Bantacut, T., Noor, E., Yani, M., Romli, M. 2022. Life Cycle Assessment of Gayo Arabica Coffee Green Bean at Aceh Province. *HABITAT*, 33(3), 308–319.
29. Purwanto, P. 2021. Cleaner Production And Waste Minimization. *Global Classroom Solid and Scheduled Waste Management*; Faculty of Civil Engineering Technology; Universiti Malaysia Pahang, 1–47. <https://doi.org/10.13140/RG.2.2.33609.16486>
30. Ramachandra, T.V., Mahapatra, D.M. 2015. The science of carbon footprint assessment. *The Carbon Footprint Handbook*, 3–44.
31. Recanati, F., Marveggio, D., Dotelli, G. 2018. From beans to bar: A life cycle assessment towards sustainable chocolate supply chain. *Science of the Total Environment*, 613–614. <https://doi.org/10.1016/j.scitotenv.2017.09.187>
32. Renzulli, P.A., Bacenetti, J., Benedetto, G., Fusi, A., Ioppolo, G., Niero, M., Proto, M., Salomone, R., Sica, D., & Supino, S. 2015. Life cycle assessment in the cereal and derived products sector. *Life Cycle Assessment in the Agri-Food Sector*, 185–249.
33. Rudenko, N.V., Ershov, V.V., Evstafiev, V.V. 2017. The Environment-Friendly Power Source for Power Supply of Mobile Communication Base Stations. *IOP Conference Series: Earth and Environmental Science*, 012024. <https://doi.org/10.1088/1755-1315/66/1/012024>
34. Sharaai, A.H., Zulkipli, L., Harun, A.H., Hui, A.Y. 2020. Social life cycle assessment (S-LCA) of cocoa production on local community and workers in Pahang, Malaysia. *International Journal of Advanced Science and Technology*, 29(9).
35. Siregar, K., Tambunan, A.H., Irwanto, A.K., Wirawan, S.S., Araki, T. 2015. A comparison of life cycle assessment on oil palm (*Elaeis guineensis* Jacq.) and physic nut (*Jatropha curcas* Linn.) as feedstock for biodiesel production in Indonesia. *Energy Procedia*, 65, 170–179.
36. Suprihatin; Nugroho, A.W.; Suparno, O.; Sarono. 2015. Life cycle assessment of integrated palm oil industry with scenarios of liquid and solid wastes utilization and integration with cattle farm. In *Proceedings The 5th Environmental Technology and Management Conference “Green Technology towards Sustainable Environment”*. Bandung, Indonesia 23–24 November.
37. UNCTAD. 2015. Cocoa industry : Integrating small farmers into the global value chain Cocoa industry : Integrating small farmers into the global value chain. *Cocoa Industry: Integrating Small Farmers into the Global Value Chain*, 7, 49.
38. Weidema, B. P., Thrane, M., Christensen, P., Schmidt, J., Løkke, S. 2008. Carbon footprint: a catalyst for life cycle assessment? *Journal of Industrial Ecology*, 12(1), 3–6.
39. Wiloso, E.I., Nazir, N., Hanafi, J., Siregar, K., Harsono, S.S., Setiawan, A.A.R., Muryanto, Romli, M., Utama, N.A., Shantiko, B., Jupesta, J., Utomo, T.H.A., Sari, A.A., Saputra, S.Y., Fang, K. 2019. Life cycle assessment research and application in Indonesia. *International Journal of Life Cycle Assessment*, 24(3), 386–396. <https://doi.org/10.1007/s11367-018-1459-3>
40. Yusuf, M.A., Romli, M., Wiloso, E.I. 2019. Carbon Footprint of Semi-Mechanical Sago Starch Production. *Journal of Ecological Engineering*, 20(11).