

Gap Between the Coach and Platform – Solutions for Improving Train Accessibility

Janusz POLIŃSKI¹

Summary

Easy access from platforms to trains is limited by the free space between the platform edge and coach floor, named the gap. The standard definition of the gap is described together with a description of all the difficulties affecting passengers, arising from different platform heights and different passenger vehicle floor placements over the rail head. The gap is a cause of accidents. The article describes techniques which are used to reduce the gap's influence on passenger safety (metro, railway), which may relate to the infrastructure, technical solutions associated with vehicles or platforms, as well as organizational solutions related with appropriate information.

Keywords: rail transport, accessibility, gap

1. Introduction

Entering a train by a passenger is associated with passing over the free space present between the coach (floor or access step) and the platform edge. Such a space is popularly named the gap. Matters concerning the accessibility of passenger trains for passengers from platforms are associated with several fields. In the case of European railways, those fields regard:

- **Platform height** – the platforms which are used have different heights, which hinders actions focused on safe train accessibility for passengers, including persons with disabilities and persons with reduced mobility. Currently, platforms with a height of 760 mm over the rail head are treated as standard ones, i.e. ones which ensure normative accessibility conditions for all types of entrances into passenger trains, according to UIC fiche 741 OR [12]. Platforms with a height of 960 mm are dedicated only for railway vehicles operating in agglomerations and with appropriate coach entrance area constructions. Platforms with a height of 380 mm are used in cases justified by special operational or architectural functionalities of individual platforms (e.g. tram-railway platforms, platforms at stations in which buildings, constructions or functional arrangements are subject to the monu-

ments conservator protection or have a historical character). It should be mentioned that designing platforms with the heights of 380 and 960 mm means obtaining derogation from technical and construction rules after obtaining a positive individual opinion of the PKP PLK S.A. board [13].

- **Gauge (clearance) of the tracks**, with which the structure gauge and loading gauge are associated; The European railway network does not have just one track gauge²,
- **Type of transport rolling stock**; from the perspective of the gap hindering transport rolling stock accessibility, highly important roles are played by:
 - floor placements over the rail head,
 - placement of the coach entrances (near end walls, in the centre of the car body),
 - number of steps in the coach (two, three, no steps),
- **Capability of utilising in international transport rolling stock running on tracks with other track gauges**, e.g. possible runs of normal gauge vehicles on a wide gauge network, causing enlargement of the space between the platform edge and the step or edge of the floor of the coach,
- **Placement of the platform**; platforms along a straight track, platforms along a curve in the track.

¹ Ph.D. Eng.; Railway Institute, Railway Track and Operation Department; e-mail: jpolinski@ikolej.pl.

² Basic track gauge is 1435 mm, however, other track gauges are present: 1520 mm (Lithuania, Latvia, Estonia, Russia, Belarus and Ukraine), 1524 (Finland) and 1668 mm (Spain and Portugal).

The gap constitutes an important hindrance for persons entering the train, as it is not possible to eliminate the gap. It especially affects passengers with disabilities and persons with reduced mobility. Therefore, different actions are undertaken, from organisational ones to technical ones. On one hand, these are aimed at ensuring maximum safety while passing over the free space between the coach and platform, and on the other hand at ensuring improvement of the trains accessibility for passengers. Such activities can be grouped as associated with:

- track,
- platform,
- transport rolling stock,
- information.

The aim of the article is to provide a closer look at the issues associated with the gap influence on accessibility and on the undertaken remedial actions, which are aimed at reducing the consequences of the gap's existence.

2. Definition of the gap and its parameters

Matters regarding the gap are described in the standard PN-EN 15273-3 Railway applications – Gauges – Part 3: Structure gauges [8]. According to the quoted standard, the gap is a two-dimensional area between the platform edge and vehicle step. This area – as shown in Figure 1 – is described by two dimensions, i.e.:

- h_{lac} – vertical distance measured between the platform edge and vehicle step,
- b_{lac} – horizontal distance measured between the platform edge and vehicle step.

Values of the parameters h_{lac} and b_{lac} depend on:

- b^q – distance between the platform edge and centre line of the track [m],
- h^q – platform height [m]. These parameters are shown in Figure 2.

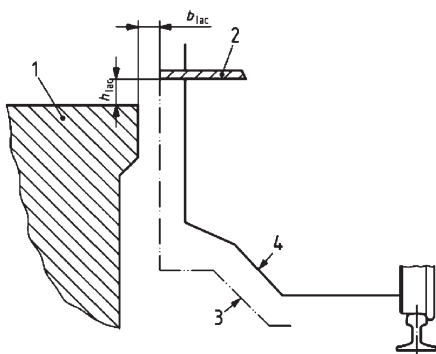

Fig. 1. Constituents important for analysed matters [8]: 1) platform, 2) vehicle step, 3) structure gauge outline, 4) vehicle outline

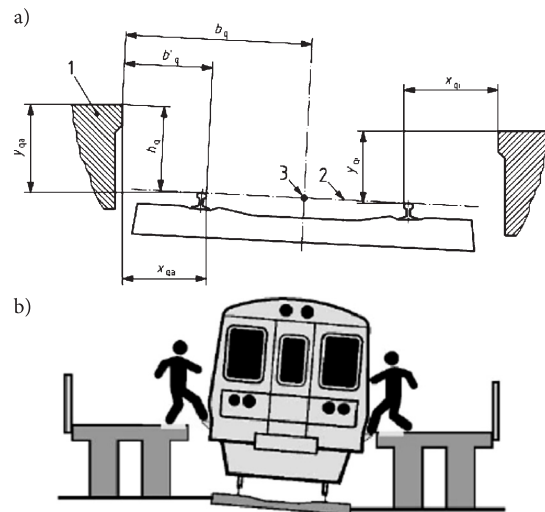

Fig. 2. Placement of the platform edge in relation to the track (a) [8], affecting placement of the vehicles stopping at platforms along a curve in the track [5]

An example of a structure gauge GA (GUA) for a 1435 mm track is shown in Figure 3. The gap size is influenced by many parameters. Among those, the following parameters should be mentioned:

- fixed parameters associated with infrastructure – Fig. 2 (e.g. platform height and its placement on the inner side of a curve, the outer side of a curve and along a straight line, size of the curve radius which influences the cant of the track) and variable parameters associated with infrastructure (e.g. constructional tolerances and maintenance tolerances),
- fixed parameters associated with vehicle characteristics (e.g. placement of the floor in relation to the rail running surface, number of access steps and distances between them, distances between bogie pivots, placement of the entrances in relation to bogie pivots, etc.),
- variable parameters, resulting from placement of the steps in relation to the track centre line (influenced by allowances and wear e.g. wear of the flanges of the wheelsets).

3. Reducing accessibility issues related to the gap

Analyses of the placement of the steps in a coach, as well as placement of its floor over the rail head, are important during analysis of the size of the gap. In accordance with UIC fiche 560 [12] and UIC fiche 741 [12], two types of entrances in coaches are distinguished, i.e.:

- with three steps (four levels),
- with two steps (three levels).

A detailed description of the matters related, among others, to rules applicable to the placement of the access steps in passenger coaches and platform heights is available in a work by Frączek and Pałyga [3]. It emerges from the information quoted above that the size of the gap is influenced significantly by the distance between the platform edge and the track centre line. In accordance with the statement in § 98 subsection 7. of the Regulation on the technical conditions applicable to railway constructions and their placement, which reads: “The distance from the platform edge to track centre line should be designed in respect to structure gauge requirements”, use of the PN-EN 15273-3 standard is obligatory [8]. It is also coherent with the statements of the technical specifications for interoperability relating to the ‘infrastructure’ subsystem of the rail system in the European Union (TSI Infrastructure), as well as with statements of the above quoted technical standards and Instruction Id-1 (D-1). According to the amended national regulations and internal regulations of PKP PLK S.A. dedicated for platforms with heights of 550 mm and 760 mm³, the distance from the platform edge to the track centre line should be nominally 1675 mm, and should not be less than 1650 mm in service.

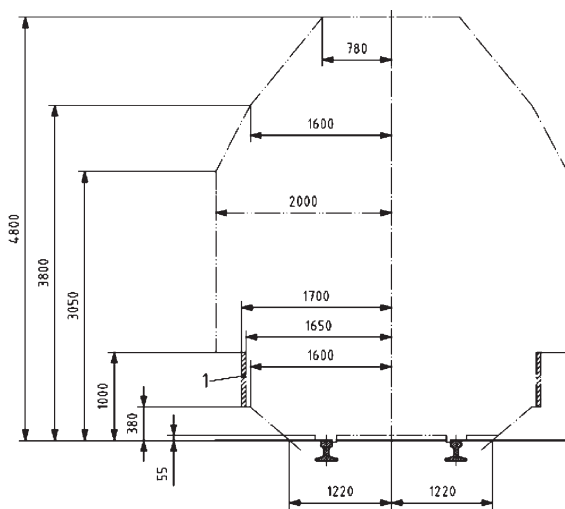

Fig. 3. Example of a structure gauge outline applied on European railways [8]: 1) platform edge mounting zone for platforms with heights from 550 to 1000 mm

It should be underlined that on some Polish railway lines, with a 1435 mm gauge, the structure gauge is 1-WM, which is obligatory on railways with a track gauge of 1520 mm. The distance between the platform edge and track centre line, which is required for such a structure gauge, is 1725 mm. This results in enlargement of the horizontal distance measured between

the platform edge and vehicle step (width of the gap), which further lowers accessibility and the safety of train boarding. This is shown in Figure 4.



Fig. 4. Enlarged horizontal distance measured between the platform edge and vehicle step in the case of the structure gauge 1-WP [14]

The vertical distance measured between the platform edge and vehicle step is a further element influencing accessibility. Its negative influence grows with the inappropriateness of the transport rolling stock for platforms. Unification of their heights to 760 mm is currently being performed step by step. In accordance with the data presented in the National Implementation Plan for the TSI PRM [9], out of 4700 platforms, 509 platforms have a height of 760 mm (10.8%). It should be mentioned that railway undertakings operate transport rolling stock with different technical solutions. This further hinders accessibility. In that respect, two types of hindering effects exist, i.e.:

- the coach floor is below the platform edge – Figure 5,



Fig. 5. Coach floor below the platform edge [photo. by Piotr Gondek]

³ Basic platform height recommended by the TSI Infrastructure. In the case of Poland, the basic platform height for the modernization and construction of platforms presently equals 760 mm [9].

- the coach floor is above the platform edge – Figure 6,



Fig. 6. Coach floor above the platform edge [photo. by Piotr Gonddek]

In the cases shown above, it is not possible to apply cheap vehicle boarding aids, which can be operated in a simple way.

4. Activities minimizing the gap influence on passenger safety

The presence of the gap (Fig. 7a) is a cause of accidents – Figures 7b) and 7c). Therefore, many rail transport managers seek different solutions, which on one hand ensure higher accessibility of railway transport vehicles and, on the other hand, improve the safety of passengers getting into or out of the trains.

Up to now, many activities minimizing the gap influence on passenger safety are applied in underground systems. That is relatively easy, thanks to uniform platform heights and respective adaptation of the transport rolling stock. In relation to railway transport, differentiated platform heights and differentiated transport rolling stock in service still constitute a problem. Therefore, it is worth taking a closer look at the directions utilised by solutions, which are aimed at improving safety and enlarging accessibility of the trains from platforms.

According to the results of research conducted by the Rail Safety and Standards Board, which are quoted in [4], the number of accidents increases by nearly 5% when the platform is wet or glaciated. When the platform is wet and glaciated at the same time, the frequency of accidents increases by nearly 20%. More accidents are recorded in winter months than in summer months [7].

Research precisely presenting safety matters in the Bangkok mass transport system platforms has proven, also as a result of questionnaires filled in by passengers, that in the case of wind and rain people are more cautious [10]. It seems, based on those results, that adverse weather conditions can have an important in-

fluence on incidents on platforms, which are exposed to weather factors.

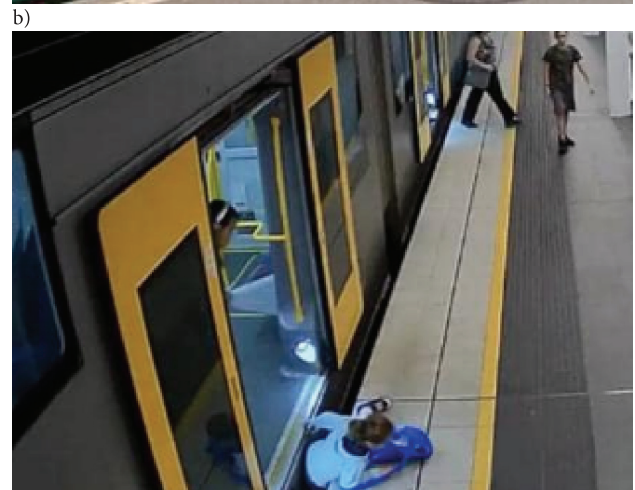

Fig. 7. Troublesome gap (a) [6], accidents caused by the gap (b, c) [15, 16]

Interesting statements regarding matters concerning the gap between the platform edge and vehicle can



Fig. 8. The way to move the platform edge towards the track centre line on the MTA Long Island Rail Road in New York agglomeration [4, 5]

be found in a publication by USA Federal Railroad Administration, pointing out the essence of enhancing passenger awareness in that respect. It encourages the use of voice announcements, signs, posters, brochures, information put on tickets and video films, etc. One of the interesting aspects in simple voice announcements was involving stars in giving information. The theory states that more people pay attention to voices which they recognise from television programs, politics or films [2].

4.1. Platform edges durably moved towards the track centre lines

There are railway lines in operation in Poland on which platforms were constructed respecting the structure gauge 1-WM (dedicated for tracks of 1520 mm). Since wide gauge rolling stock no longer enters the PKP network, this only constitutes additional widening of the gap for passenger rolling stock, as shown in Figure 4. An interesting solution, which can minimize the width of the gap and is utilised by MTA Long Island Rail Road, is to minimize the gap in such cases by fixing wooden beams to the edge of platforms. This is shown in Figure 8.

On one of the lines in Ottawa, the problem of the existing gap was solved in another way. It concerned agglomeration railroads on which only one type of train operates and where there is no freight transport. Wooden plates were mounted to the edges of platforms. The plates are placed only in places where the doors are present when trains stop – Figure 9.



Fig. 9. Solution on agglomeration railroads in Ottawa [4]

4.2. Tracks moved towards the platform edge

On railway lines on which mixed operation is performed (freight and passenger traffic), keeping wider distances between the platform edge and track centre line is justified by the transport of out-of-gauge loads. In order to ensure, on one hand, transport capability for such freight trains and, on the other hand, a minimized gap for passenger trains, a special constructional solution was applied. An additional track moved towards the platform edge was constructed along the platform. One example of this method can be found on the Westside Express Service (WES) line operated by the Tri-County Metropolitan Transportation District of Oregon (Trimet) in Portland in Oregon – Figure 10a), and a second one in Kaufungen in Germany – Figure 10b).



Fig. 10. Moved tracks [9]: a) Portland – USA, b) Kaufungen – Germany [17]

4.3. Differentiated height of a single platform

One of the most significant hindrances regarding easy access to trains is differentiated platform heights. It is worth mentioning solutions utilised in that respect both by Canadian Railways and North-America Railroads. For example, in Canada most platforms are low. In order to ease access for persons with disabilities and persons with reduced mobility, platforms are equipped with short (10 to 15 metres long) pavements raised up to the height of the coach floor – Figure 11a). Linking platforms with the small platforms is obtained thanks to stairs, ramps and sometimes lifts. It should be mentioned that disabled passengers utilise a specially adapted coach, which stops at the raised part of the platform. Passengers enter the train over a step board, manually laid down by the train crew, which is made of duralumin – Figure 11 b).

The height of the part of the platform levelled with the height of the coach floor over the rail head allows use of extra simple technical solutions (step boards), which are user-friendly and cheap in purchase and operation.

4.4. Devices fixed to the platform construction

Special construction footbridges, which constitute platform elements, are used on railway lines which are used during the day for passenger transport and during the night for freight transport. They are incorporated into the platform construction in places in which the doors of stopped passenger vehicles are located (Sprinter Light Rail system). The device is equipped with a hydraulic drive. Laid down, it moves the platform edge towards the vehicle. Laid up, it ensures continuity of the platform fence protecting the track ready for freight transport.

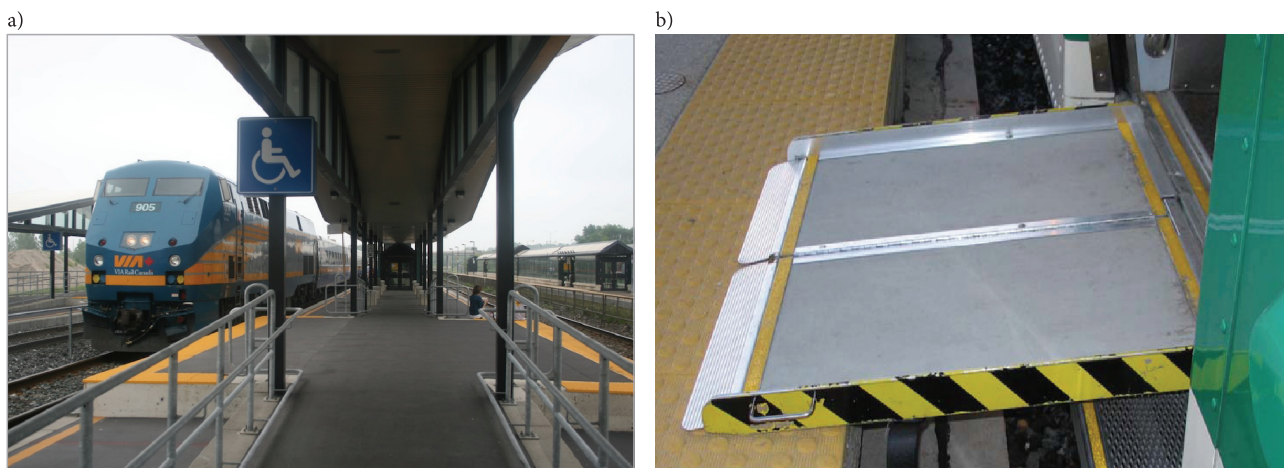

Fig. 11. Canadian Railways: a) raised part of platform [19], b) laid down step board [18]

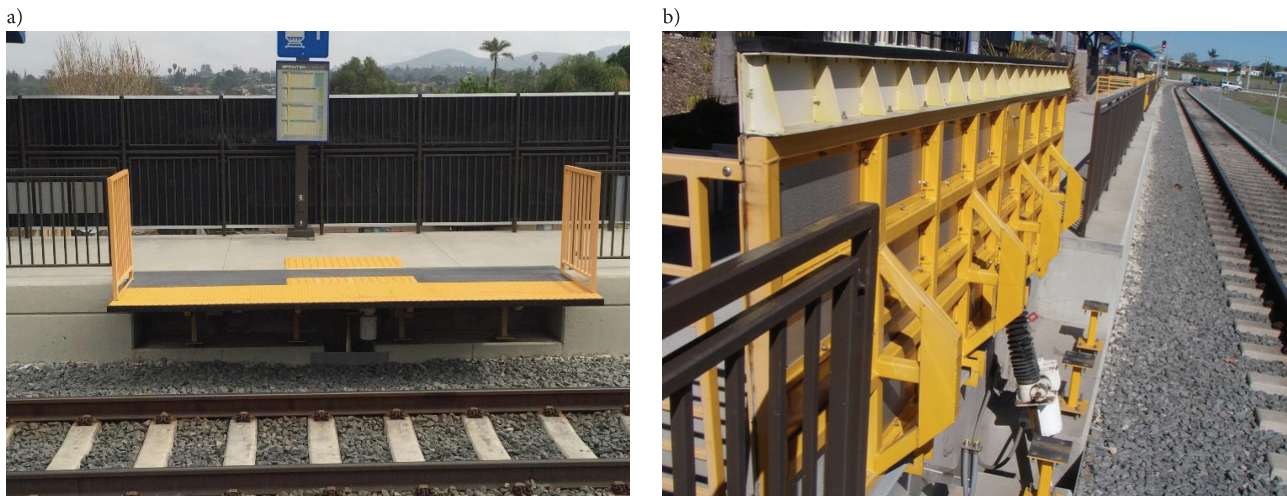

Fig. 12. View of a laid down footbridge (a) [4], laid up footbridge (b) [20]

Such a solution has been applied by NCTD Railway on one of its lines in California used for the transportation of out-of-gauge loads. Footbridges are controlled remotely by train dispatchers from the central control centre. Freight trains can enter the track after proving, via the system display and platform supervising cameras, that all footbridges are laid up. Additionally, the laying of each footbridge is associated with train signalling. If not all footbridges are laid up successfully, the signal stays red and forbids train movement. Footbridges are shown in Figure 12.

Slightly different in operation is the RATP BI system based on a protractile step board emerging from the platform. The solution was tested in 2007 at the Place d'Italie metro station in Paris. In addition to placing the device in platforms along a straight track, this technical solution can be mounted in a way that also ensures constant width of the gap on track curves – Figure 13.



Fig. 13. Footbridge emerging from a platform [1]

On the basis of the tests already conducted for this solution, it was found that it can be used together with fully automated train operation [1].

4.5. Devices which are moving on the platform

Platform lifts are also considered as boarding aids easing access from the platform to train. Usually, such devices are operated manually, are user-friendly in operation and use, and can be moved on the platform pavement. They enable entrance to a coach adapted for wheelchair user passengers, both for manual wheelchairs and much heavier ones – electrical. The device requires service by trained railway personnel. Due to organizational matters, the platform lift should be moved to the stopping place for coaches adapted for disabled passengers, before train arrival.

Devices of that type are not used in Poland, except for tests associated with application at a few bigger passenger stations. It should be mentioned that such lifts are, however, commonly used on German, Swiss, Italian, Slovak and Czech railways. Sample platform lifts used on Swiss and German railways are shown in Figure 14.

Constructions of devices which are fixed to platforms are developing continuously. It is worth mentioning an Italian project named PANDA STATION, which was ended in the year 2017. The device can be operated by a disabled person on a wheelchair and can be wheeled manually by railway personnel. The possibility of earlier driving into the device by the wheelchair user and moving towards the defined coach (the coach adapted for disabled persons does not need to stop in a predefined place along the platform) is an advantage of this construction. Storage batteries permit 100 work cycles before the next charging. The lift can hold 350 kg and can lift a wheelchair up to the height of 1 metre. The solution is shown in Figure 15.

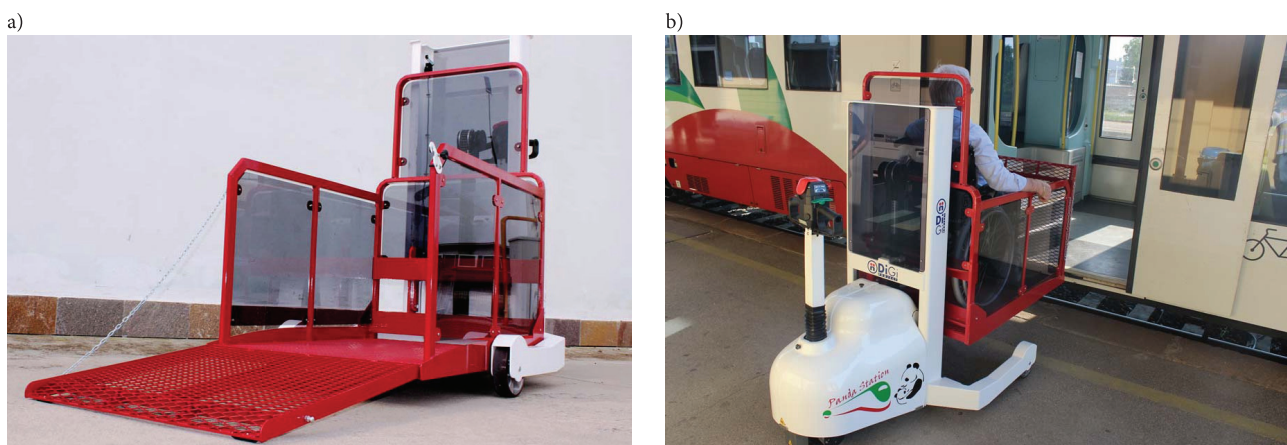
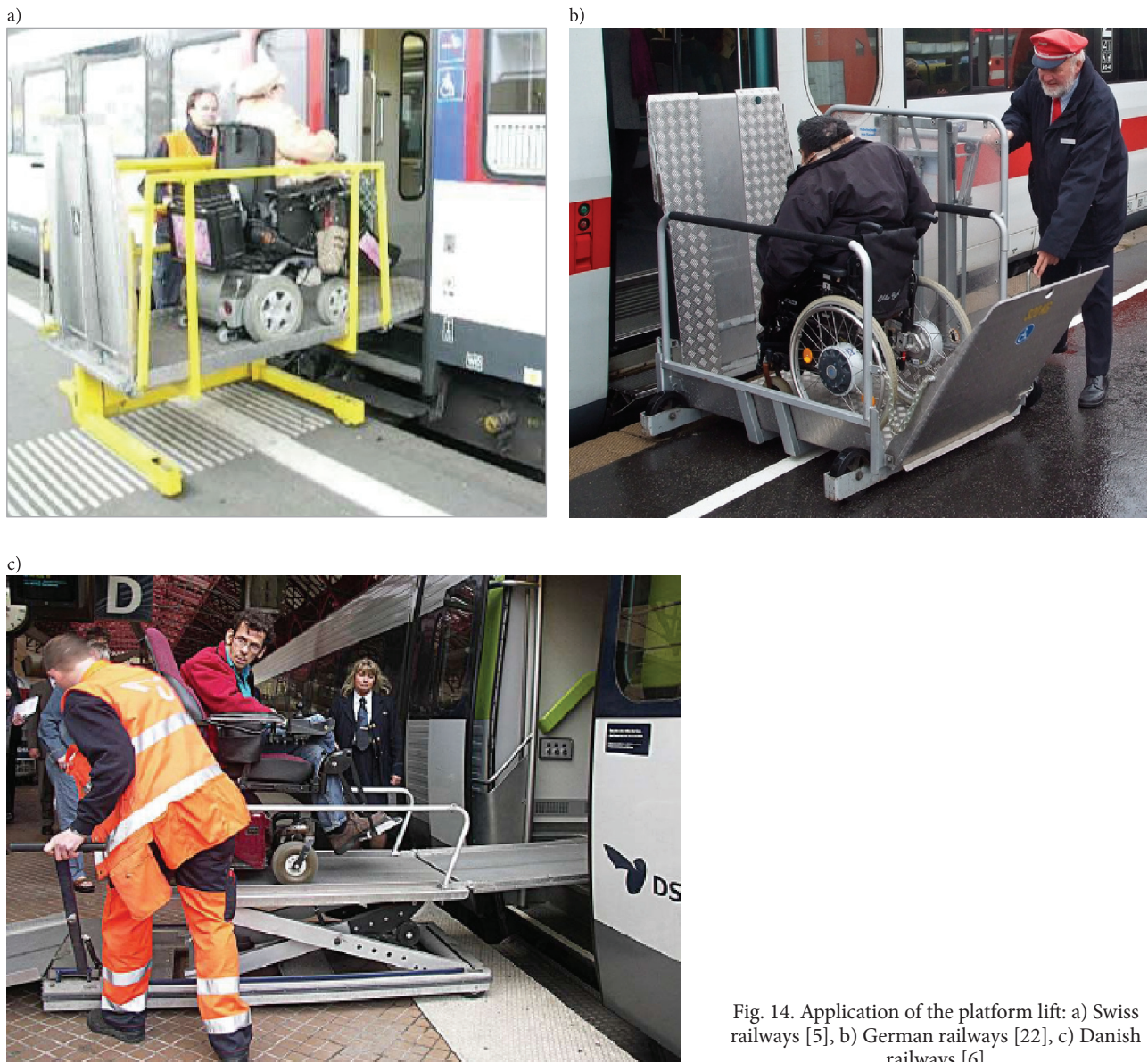

4.5. Devices fixed to the coach construction

Devices which are mounted in transport rolling stock are available at each commercial train stop. This is an advantage of such constructions. Attendance of devices is ensured by on-board train staff. Such a solution for disabled persons enables access to and egress from the train, and therefore increases the mobility of that passenger group, even without earlier coordination of the journey. This is important both for railway operators (there is no need to organise access to a train for a disabled person) and for travellers (simplification of the arrangement of a journey). In relation to the technical solutions in utilised devices, they can be divided on the basis of the propulsion source into:

- manual devices, and
- mechanical devices (usually with electrical propulsion).

On the basis of the technical solution and scope of the application train, boarding aids can be based on the following technical solutions:

- **electrical lifts mounted near coach doors**; basically, the lift can serve only one side of the vehicle, therefore adapted coaches should have two identical lifts as platforms can be located on both sides of the coach; a distinguishing feature of such devices is the ability to pass over both the width and height of the gap, ensuring at the same time:
 - device usage availability both for wheelchair users and for persons with reduced mobility,

- the ability to move disabled persons practically from all platform heights to the train board and back (providing that the deck of the lift is equipped with a guarding balustrade).

A sample lift solution (frequently called an elevator), mounted in Pendolino trains is shown in Figure 16a). To utilise the lift for other groups of disabled persons (the lift is not equipped with a balustrade) each Pendolino train operated by the railway undertaking has, at its disposal, a special chair on which the passenger sits during operation of the device – Figure 16b).

- **Laid down ramps**; this type of solution of devices utilised for gap overpassing is relatively widely used on Polish railways. They have been developed continuously for over ten years. As a result, devices of that type are currently simple in use, lightweight, and take little space while in transport mode – Figures 17, 18.
- **protractile steps** used in the case of passenger vehicles running on railway lines on which platform edge placement is differentiated. When they are placed on different heights from the rail head, and the car body solution enables easy access from high platforms, solutions with protractile steps are used. Such a solution enables entrance of the train by healthy passengers and persons with some types of disability. Such a solution does not enable wheeling on by a traveller using a wheelchair and does not enable stepping in for most persons with



Fig. 16. Lift mounted near the coach doors: a) while lifting a traveller on a wheelchair [22], b) chair on a lift for persons with reduced mobility who do not use wheelchairs [23]

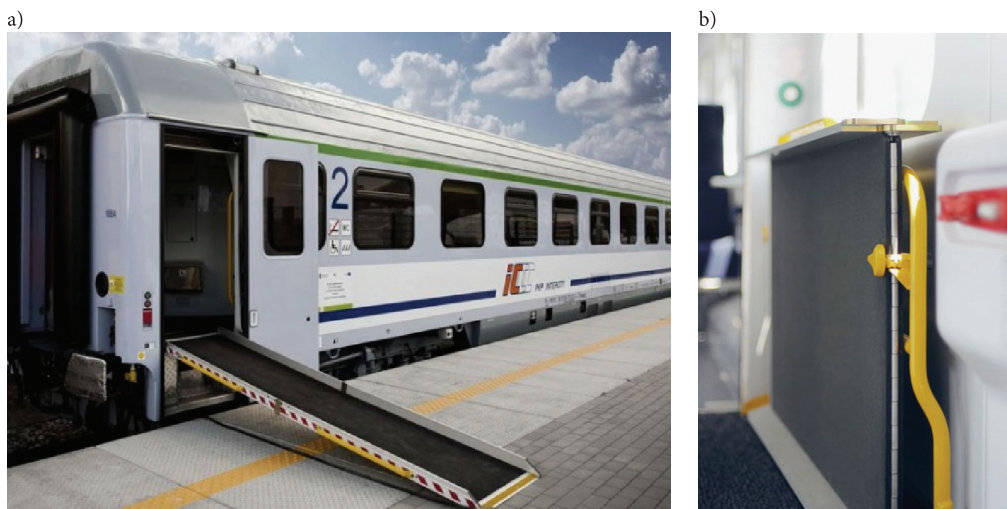

Fig. 17. Coach type 168A ramp: a) laid down, b) laid up in a coach [photo by NEWAG]

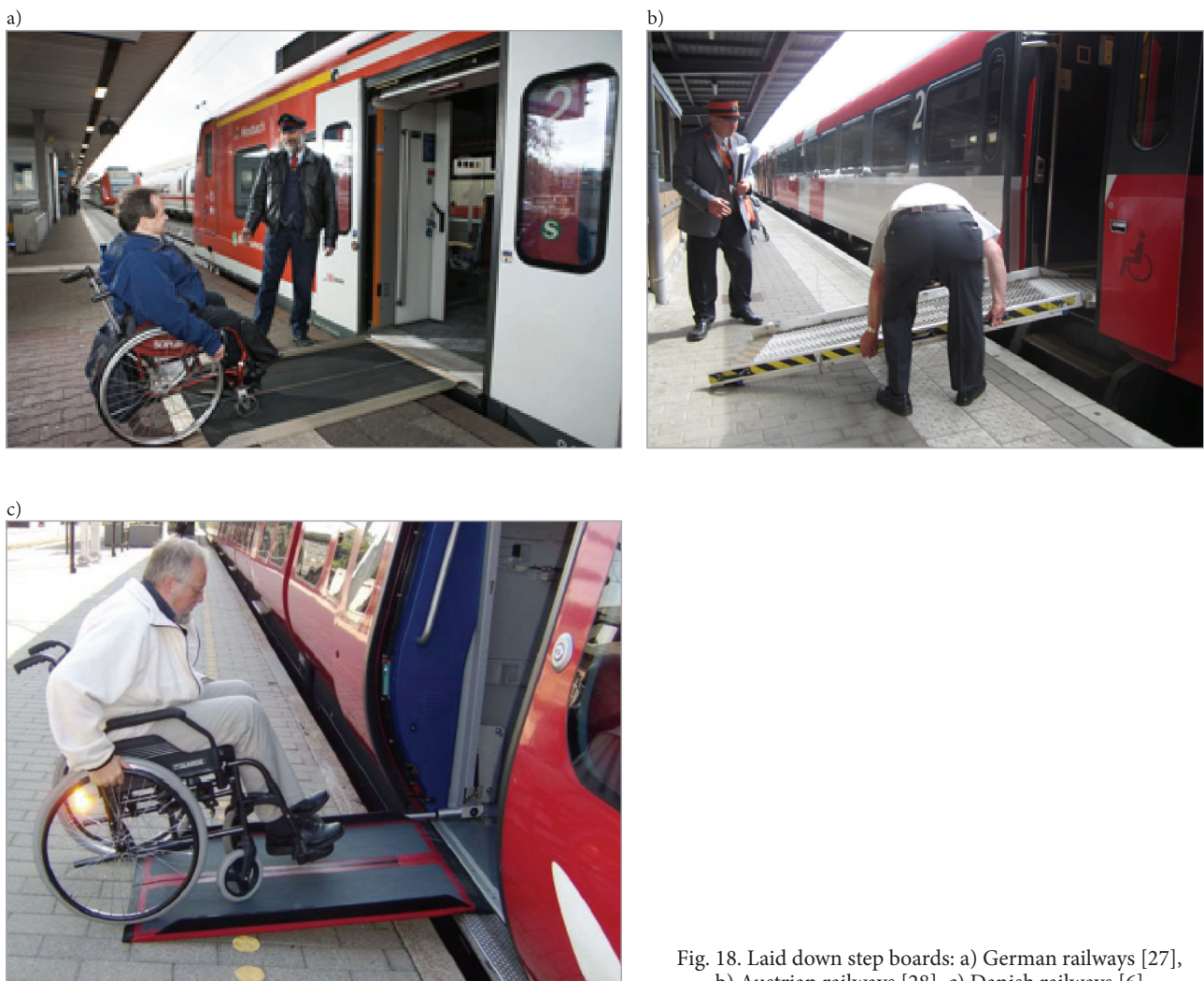

Fig. 18. Laid down step boards: a) German railways [27], b) Austrian railways [28], c) Danish railways [6]

reduced mobility – Figure 19 in which the vehicle type ED74 is shown with propounded steps.



Fig. 19. Vehicle type ED74 with propounded steps [29]

- **protractile or revolvable gap covers;** this type of solution is used in locations where it is important to improve safety while serving a large flow of travellers. In such cases, when there is a minor difference between the heights of the platform edge and coach floor,

a cover may act as a step (therefore it is frequently named a step). Most often, such a solution can be found in rolling stock for urban and agglomeration railways. Railway undertakings which operate rolling stock conformed to platform heights (coach floor located on the platform edge height) utilise such a solution only in doors dedicated for wheelchair users and persons with reduced mobility. Examples of both solutions are shown in Figure 20.

4.6. Other solutions

This group comprises solutions which can constitute installation in a passenger vehicle and platform installation. Different types of drive chute is an example of such a solution. As shown in Figure 21, they are composed of two separate elements, which are used to guide the wheels of the wheelchair. This solution cannot be used by other persons with disabilities and persons with reduced mobility. Such solutions are used in places where the difference between the platform edge and coach floor is bigger. Such solutions, how-

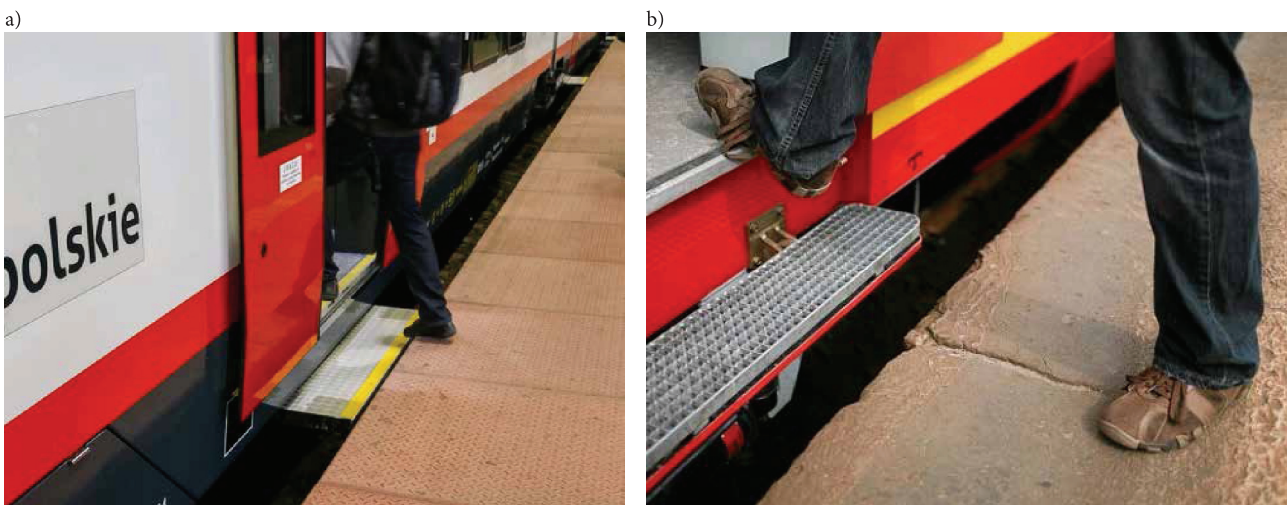

Fig. 20. Gap cover [39]: a) protractile, b) revolvable

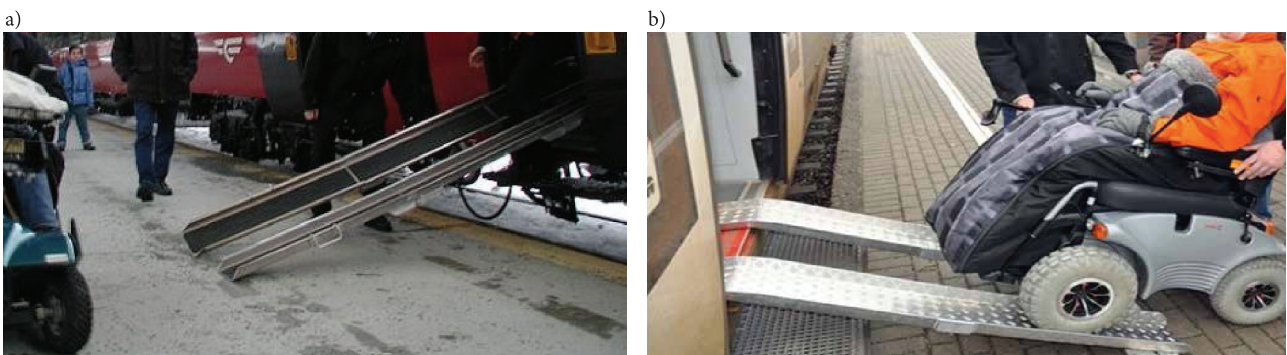

Fig. 21. Drive chute: a) Swedish railways [25], b) German railways [26]

ever, do not belong to safe ones, nevertheless, they are utilised in operational practice.

4.7. Information on platform

Aside from the many technical solutions described above, an important role is played by visual and voice announcements. In English-speaking countries, “Mind the Gap” is written along platform edges in

danger areas (meaning: pay attention to the distance between the platform and train or, briefly, pay attention to the gap). This is written in a way that it is readable both for people on the platform and for people stepping out from the train – Figure 22.

Aside from horizontal character strings put in danger areas, there are also different types of pictograms informing about the gap, which are put on passenger stations and platforms (information put vertically) – Figure 23.



Fig. 22. Character string on platform surface: a) character string readable from the platform (metro) [30], b) character string readable from the coach (metro) [31], c) character string on a railway platform [31]



Fig. 23. Examples of pictograms dedicated to paying attention when passing over the gap between the platform and train [32–34]



Fig. 24. Information on the coach doors [35–37]

4.8. Information in trains

Information for travellers about imminent danger when leaving the train is also contained in the interiors of vehicles. This concerns pictograms put on the inner side of the doors – examples in Figure 24, and also information given on the displays – Figure 25.



Fig. 25. Information about the necessity to pay attention to the gap when leaving, which are given on a display [38]

5. Luka in the assessment of different people

In the year 2014, the SKM in Tricity carried out a survey for passengers asking: Does the space between the train and platform constitute a significant hindrance for passengers? There were four possible answers. In that respect, 1793 persons responded. The following answers were obtained:

- **YES**, many persons resigned from getting around with SKM trains – 58%,
- **YES**, however, the problem concerns only a small group of passengers – 30%,
- **NO**, after all, this distance is not so big to hinder access or egress – 7%,
- **NO**, this is a short distance, moreover, more and more trains are equipped with special decks, which can be laid down on passenger demand – 5%.

This survey proves that matters associated with the gap between the platform edge and coach floor

strongly influence trains accessibility and is very important for passengers. Therefore, it can be stated that the level of accessibility has a direct impact on the size of the passenger flow (amount of traffic).

6. Conclusions

The conducted overview of the technical solutions utilised in rail transport shows that the technical solutions used in Poland are associated with transport rolling stock. Hence e.g. platform lifts are not used for improving accessibility.

The simplest and, at the same time, cheapest solutions can be used when the height of the coach floor is similar or equal to the platform height. When this condition is not fulfilled, it is necessary to use such technical solutions which enable passing over the vertical and horizontal distance between the platform edge and coach floor by passengers – especially by disabled persons and persons with reduced mobility. For this purpose, different technical solutions are utilised, like lifts mounted near coach doors and laid down ramps, etc.

There is a high differentiation between platform heights in Poland and transport rolling stock in operation. Upgrading of the infrastructure and modernization of the utilised rolling stock fleet is long lasting and requires high financial input for realisation. Data in that respect are included, among others, in the National Implementation Plan for the TSI PRM. Therefore, gap overpassing passenger safety matters will be important for rail transport for a long time.

The overview of the technical solutions utilised abroad permits the assumption that in Poland due attention is not paid to information for passengers about the dangers arising from passing over the gap between the platform and coach. Appropriate marking of platforms with horizontal information (character strings put in a danger area) and vertical information (pictograms) should be provided by infrastructure managers. As character strings are not present either in the metro or on railways, there is a chance to elaborate the

graphic elements together. Similar activities should be undertaken by railway operators in their rolling stock. They should elaborate together appropriate graphic elements for the inner side of doors, and the content of information appearing on displays, which do exist in most of transport rolling stock. It is also worth introducing unified voice announcements for use both at passenger stations and in trains.

The issues described in the article are currently being resolved within the FAIR Stations and In2Stempo projects (work package WP8, which is conducted together by Railway Institute and PKP S.A.).

Literature

- Evaluating Platform Gap Fillers to Reduce Risk at the Platform / Train Interface Appendices. Rail Safety and Standards Board Limited, 2016.
- FRA Approach to Managing Gap Safety, Federal Railroad Administration Office of Safety, 2007.
- Frączek R., Pałysa J.: *Czynniki warunkujące wybór standardowej wysokości modernizowanych peronów osobowych na sieci PKP oraz zakupy i modernizacje taboru*, Problemy Kolejnictwa, Zeszyt 141/2006.
- Improving Safety of the Platform-Train-Interface Through Operational and Technical Mitigation Strategies, <https://ir.library.oregonstate.edu/downloads/nc580p83x> [access 09.07.2018].
- Kenny R.P.: *Addressing the Gap*, MTA Long Island Rail Road 2007.
- Nielsen L.: *Transport for all. Disabled and older people should have the right to travel with the same freedom and spontaneity as everybody else*, Disabled Peoples Organizations Denmark, 2017.
- Passenger risk at the platform-train interface, Rail Safety and Standards Board (RSSB), London, UK, 2011.
- PN-EN 15273-3 Kolejnictwo –Skrajnie – Część 3. Skrajnie budowli.
- Poliński J., Wróbel I.: *Krajowy Plan Wdrażania technicznych specyfikacji interoperacyjności odnoszących się do dostępności systemu kolei Unii dla osób niepełnosprawnych i osób o ograniczonej możliwości poruszania się (TSI PRM)*, Instytut Kolejnictwa 2017.
- Santoso, D.S., & Mahadtha S.: *How Safe is the Rail Platform? A Study of Bangkok Mass Transit System (BTS)*, Eastern Asia Society for Transportation Studies, Retrieved from <http://easts.info/on-line/proceedings/vol9/PDF/P233.pdf> [access July 20, 2014].
- UIC 560: Doors, footboards, windows, steps, handles and handrails of coaches and luggage vans.
- UIC 741 OR: Passenger stations – Height of platforms.
- Wytyczne w sprawie doboru wysokości peronów na liniach kolejowych zarządzanych przez PKP Polskie Linie Kolejowe S.A. Id-118, Warszawa, 2013.

Źródła internetowe

- <https://www.facebook.com/MagazynKolejowy/photos/a.1908935786000084.1073741828.1908428222717507/1908935896000073/?type=3&theater> [access 05.07.2018].
- https://myaccount.news.com.au/sites/dailytelegraph/subscribe.html?sourceCode=DTWEB_WRE170_a_GGL&mode=premium&dest=https://www.dailytelegraph.com.au/news/nsw/hundreds-of-children-nearly-fall-to-their-death-at-train-stations-across-sydney/news-story/a2f15cef99acf03fd8c9073210f70cd2&metype=anonymous [access 06.07.2018].
- <http://www.dailymail.co.uk/news/article-3745273/Falling-gaps-near-misses-tracks-Terrifying-video-train-station-accidents-shows-need-beware-way-work.html> [access 06.07.2018].
- https://wikivisually.com/wiki/Gauntlet_track [access 06.07.2018].
- <http://www.gotransit.com/public/fr/docs/publications/AccessibilityPlan2009-2010.pdf> [access 30.10.2012].
- http://www.subwaynut.com/canada/go_transit/aldershot/aldershot4.jpg [access 09.07.2018].
- <http://www.ulmerind.com/projects/sprinter.htm> [dostęp 09.07.2018].
- <http://mobilista.eu/309/deutsche-bahn-ohne-hublifter-in-ice-ausblick/> [access 18.04.2018].
- <https://www.robimypodroze.pl/2017/08/pendolino-swietny-pociag-dla-osoby-niepelnosprawnej/> [access 10.07.2018].
- <https://www.intercity.pl/pl/site/o-nas/dzial-prasowy/aktualnosci/krzeselka-dla-niepelnosprawnych-w-pendolino.html> [access 10.07.2018].
- <http://www.digiproject.biz/en/portfolio/pandastation-train-station-lift/> [access 10.07.2018].
- <http://www.breutel.de/tour2002w/htm/11032002.htm> [dostęp 12.07.2018].
- <https://www.dorstenerzeitung.de/Staedte/Selm/Rollstuhlfahrer-gluecklich-Rampe-besteht-Bahn-Test-Plus-1152717.html> [access 12.07.2018].
- <http://www.germany.travel/en/ms/barrier-free-germany/how-to-book/deutsche-bahn.html> [dostęp 12.07.2018].
- <http://www.kijikiji.com/colum/euro8/amsterdam.htm> [access 12.07.2018].
- http://inforail.pl/peron-pociag-strefa-usprawnien_more_57994.html [access 12.07.2018].
- <https://www.latmultilingual.com/3-important-facts-about-canadian-labelling-laws/> [access 14.07.2018].
- https://en.wikipedia.org/wiki/Hartlebury_railway_station#/media/File:Hartlebury_railway_station,_geograph-3752504-by-Nigel-Thompson.jpg [access 14.07.2018].

32. <https://mobile.twitter.com/CapeTownTrains/status/997519750753341440> [access 14.07.2018].
33. <https://creativepool.com/cjbouchermedia/projects> [access 14.07.2018].
34. <http://www.merseyart.com/2010/03/sign-oftimes.html> [access 14.07.2018].
35. <http://picssr.com/photos/lrosa/interesting/page-5?nsid=30571787@N00> [dostęp 14.07.2018].
36. <https://www.tripadvisor.com/LocationPhotoDirectLink-g189852-i20319044-Stockholm.html> [access 14.07.2018].
37. <https://www.answerplane.com/london-underground-mind-the-gap-sticker/> [access 14.07.2018].
38. <https://www.youtube.com/watch?v=wqZDucQK17Q> [dostęp 14.07.2018].
39. https://www.pfon.org/images/dodatki/201505_koleje.pdf [access 20.01.2019].