

DOI: 10.5604/20830157.1093196

## QUALITY MANAGEMENT SYSTEM IN HEAT SUPPLY OPERATION

Nigina Toktasynova<sup>1</sup>, Gulmira Bazil<sup>2</sup>, Shinar Adilova<sup>2</sup>

<sup>1</sup>Almaty University of Energy and Communication, Faculty of Engineering Cybernetics, <sup>2</sup>Kazakh National Technical University after K. Satpayev, Institute of Information and Communication Technologies

**Abstract.** In the article, the Quality Management System (QMS) in heat supply is shown as high-quality and reliable heat supply ensuring system for consumers (in the most cost-efficient way compliant with environmental standards) and ensuring the quality assessment of functioning business. The article provides features of heat supply, as control object, and difficulties of assessing the quality of functioning business. It also provides a process approach to description and management of activity, as one of management principles in QMS.

**Keywords:** management of district heating, the hierarchical system, the system of management and quality

### SYSTEM ZARZĄDZANIA JAKOŚCIĄ W DOSTARCZANIU CIEPŁA

**Streszczenie.** W artykule system zarządzania jakością w dostarczaniu ciepła potraktowano jako system zapewniający wysoką jakość i niezawodność dostarczania ciepła klientom w najbardziej ekonomiczny sposób, przy jednoczesnym zapewnieniu standardów ekologicznych i uwzględnieniu oceny jakości funkcjonowania przedsiębiorstwa. Wskazano cechy szczególne dostarczania ciepła jako obiektu sterowania oraz trudności w ocenie jakości funkcjonowania przedsiębiorstwa. Przyjęto podejście procesowe do opisu i sterowania dostarczaniem ciepła jako zasady sterowania systemem zarządzania jakością.

**Słowa kluczowe:** zarządzanie dostarczaniem ciepła, system hierarchiczny, system zarządzania jakością

### Introduction

Currently, many enterprises to improve the performance and competitiveness of the domestic and global markets are implementing the Quality Management System. How does the introduction of this system in a centralized heating system will affect the quality and reliability of supply, whether it will increase energy efficiency, in accordance with environmental standards? Allow to achieve this goal, and to assess the quality of operation of the business. These and other questions will try to answer in this article.

### 1. Features heating as a control object

Contemporary district heating systems (DHS) of cities correspond to complex technological systems consisting of basic interrelated district-heating processes (CHP and auxiliary boiler rooms), main and sub-main heating utilities (HU), and spatially distributed network of heat and domestic hot water (DHW) consumers.

Operation of DHS shall be in compliance with technical requirements to hydraulic/thermal modes and to reliability of components – regarding the technical-economic indicators of heat supply [7].

As the target of research and control, HS is characterized by [4]:

1. Complex interrelationships between heating, domestic hot water, and ventilation processes;
2. External links to other facilities (water supply and CHP);
3. Continuity in production, distribution, and consumption of thermal energy;
4. Dependent and independent schemes of connecting the thermal energy consumers to heat-supply system;
5. Non-stationary nature of hydraulic and thermal heat-supply modes;
6. Stochastic nature of disturbances;
7. Problems in assessing the current values of technical-economic indicators (process management quality);
8. Spatial distribution of heating facilities;
9. Increased sensitivity of heat carrier to water leaks and accidents – in areas and nodes of heating utilities;
10. High-density of heat carrier, which requires additional power costs for network water pumping and arrangement of high pressure – to fill the heating elements of consumers.

Activities of heat-supply plant are estimated by the following components [8]:

- quality of maintaining the technical status of heating utilities;
- modal reliability;
- quality of remediation activities;
- quality of building and replacing the heating systems;
- reliability management at the enterprise.

### 2. Quality management system in management heat supply

In practice, it is often difficult to assess the quality of functioning enterprise: compliance between quality of products (goods or services) to set requirements, correct and transparent business management, activities to improve the functioning of business processes, correct record keeping, competence and satisfaction of employees, and, finally and most importantly, customer satisfaction. DHS also has difficulties arising from specific feature of activity – presence of feedback: heat carrier (water) heated to certain temperature at CHP heating units is transported and distributed to consumers of thermal energy, while returning to source of heat with residual temperature. As main purpose of DHS functioning is to ensure the high-quality and reliable heat supply of consumers (in the most cost-efficient way compliant with environmental standards), there is a need for system ensuring the achievement of this goal and assessing the quality of functioning business. In the world community, Quality Management System (QMS) is considered to be such system.

QMS is designed to ensure the sustainable success of organization and provides the manager with opportunity to analyze the performance of enterprise and production of competitive products; employees – with opportunity to evaluate the results of their actions and be aware of relevance and importance of actions taken; consumers – with opportunity to assess the meeting of requirements related to products and/or services.

QMS ensures the quality management of services – via management of processes [1] forming the quality. This is possible at implementation of basic management functions [5]: interaction with external environment, forming a policy and planning of quality, training and motivation of staff, arrangement of quality-ensuring activities, quality control, information on quality, development and implementation of actions on improving the quality of services. All these functions are inter-related and form a quality management process within the enterprise.

While reviewing this system (QMS) as management object, let us provide its block diagram:

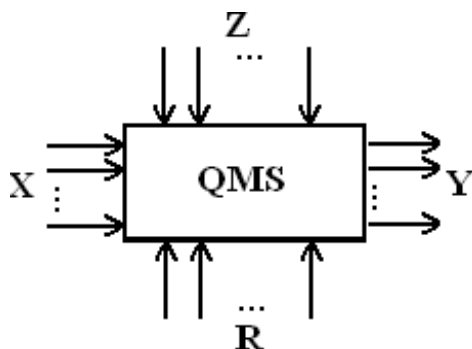

Fig. 1. Block diagram of QMS control

where  $X=(x_1, x_2, \dots, x_n)$  – input requirements to system: requirements to documentation, work of staff, quality of services, etc.;

- $Y=(y_1, y_2, \dots, y_q)$  – output data for system analysis (audit) and monitoring;
- $Z=(z_1, z_2, \dots, z_p)$  –disturbances: critical and emergency situations, human errors, untimely or inadequate (to input requirements) service of providers.
- $R=(r_1, r_2, \dots, r_m)$  –resources needed to meet the system requirements and obtain the necessary results (resources intended for preventive and corrective actions).

Full description of the system consists of mathematical model (control object) used for purposeful conversion of input data to outputs – subject to disturbances and resources.

In scientific research, function is the most common model of transforming the input to output. Classic formalized (explicit) representation of function in mathematics

$$Y=f(X, Z, R),$$

If we transfer the mathematical concept of function to process and correlate it with definition of the process under ISO 9000, the above expression can be interpreted as follows: given the process inputs  $X$ , convert them to output  $Y$  according to conversion rule  $f$ .

As seen from Figure 1, overall structure of the process can be formally represented by two components:

- objects – inputs ( $X, Z, R$ ), outputs ( $Y$ ) answering the question "what"
- functions – conversion rules  $f(X, Z, R)$  answering the question "how".

Function is a specific model (representation) of process describing the rules of transforming the inputs to process output. In other words, the function describes how and what should be done as part of the process – for output (product) to be compliant with certainly set requirements.

In contrast to mathematical function, function related to process shall determine the following:

- what types of input objects must be received at the input of process and without which categories and (or) specific objects the function cannot be implemented?;
- under what rules and into what relations are involved the various categories of input objects during implementation of the process?

It is obvious that, from two identified components, function is the most complete representation of the process, which indirectly comprises the objects too. Therefore, for the purpose of evaluation, analysis, and improvement, each process (activity, work, operation, action, etc.) may be represented in the form of its model – function. The function acts as uniform building block used to construct the process and its components.

For consistent perception of complex process and ease of its analysis, "functions" at each level of hierarchy shall belong to the same class, i.e., have the same set of properties [6].

Projection of formal description to real materialized process enables the control of output compliance. For example, processes of high-quality heat supply can be subject to application of measurable quality parameters (projections at the output). Deviation of resulting features from set parameters demands the correction of process description, reconfiguring of processing parameters, and bringing the characteristics to normal.

The system (QMS) shall be adequate to object and have an opportunity for integration with other management systems.

According to international standard ISO 9001, QMS introduction assumes the following milestones:

- development of quality objectives;
- description of main and auxiliary processes;
- development of process indicators;
- development of QMS documentation;
- familiarizing the staff with documentation;
- keeping the QMS documents up to date;
- collection of measurement results;
- planning and conducting of internal audits;
- data analysis;
- development of corrective and preventive actions, addressing of inconsistencies;
- improvement.

In QMS, one of management principles is use of process approach to description and management. Use of process system along with identification/interaction of the processes (within the enterprise), as well as their management aimed at obtaining the desired result, can be viewed as "process approach" [2]. Dynamic development of market and environment keeps bringing the managers to idea that management of enterprise is a set of business processes defining the essence of activities within organization.

Business process is understood as sustainable and targeted set of interrelated activities using certain technology to transform the resources (materials, funds, equipment, personnel, information) into result (product, service) being of value to consumer or enterprise. The following is necessary to implement the process approach:

1. Identify the main and auxiliary processes affecting the management quality and efficiency, as well as the processes related to consumer;
2. Identify the persons responsible for planning, analysis, and development of recommendations on process improvement (owners); provide them with necessary authorities;
3. Determine the process goals – based on objectives of organization;
4. Set the process boundaries, inputs, and outputs;
5. Develop the process documents (procedures, rules, maps, diagrams, etc.);
6. Develop a management, monitoring, and process measuring system;
7. Provide the processes with necessary resources and run the processes;
8. Control the processes via monitoring and measurement; Plan and implement the process improvements – based on Deming cycle (PDCA cycle).

While breaking the activities of HS enterprise to processes, we get the following: planning, design, production, purchasing management, analysis, and control.

Process approach, along with general ideology, includes description of activities, as network of interrelated processes, and permanent monitoring, management, and improvement of processes. For high-quality management of business processes, they shall be provided with compliant indicators of functioning and efficiency. These figures shall meet the set requirements, deviation from which is considered as non-compliance. QMS system shall collect information on values of process indicators and revealed non-conformities.

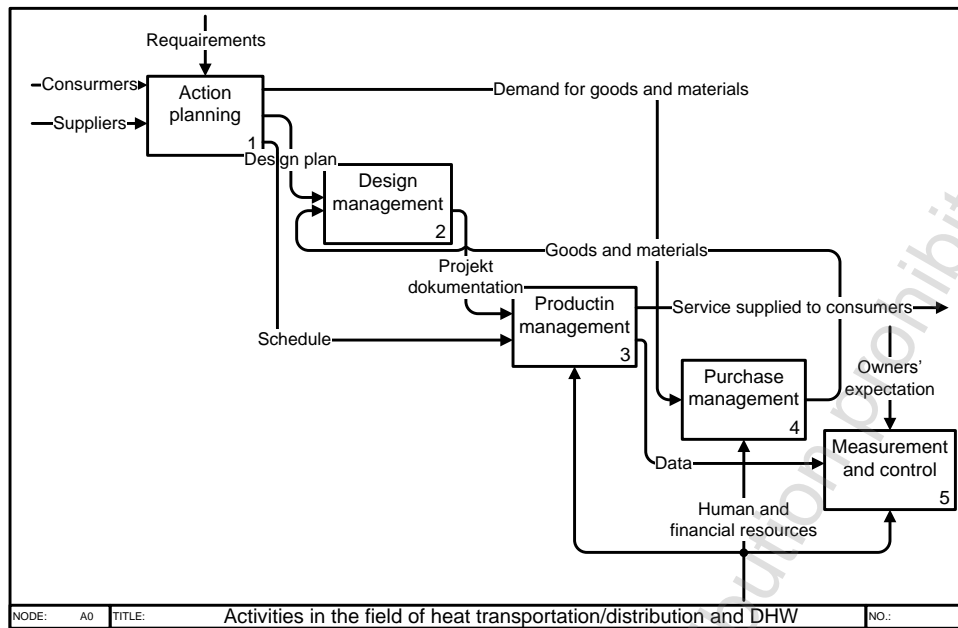

Fig. 2. Business processes of HS enterprise

In case of incompliance, mandatory procedures shall include identification of consequences and causes, significance of which can be estimated by grading system. Quite often, assessment uses a method of analyzing the incompliance, its consequences, and causes (FMEA – Failure Mode and Effects Analysis) – with use of cause-and-effect Ishikawa diagram (introduced in MS ISO 9004-4:94), which applies the risk priority number (RPN). Emergence of incompliance can be dependent on many factors. At that, some of them may affect the others, i.e., be bound with cause-and-effect relations. Definition of entire cause chain can successfully solve a management problem – including the quality management. So, FMEA method on analysis of activity recommends corrective and preventive actions to reduce the severity of consequences or likelihood of failure for the enterprise.

### 3. Conclusion

Thus, QMS establishment in heat supply will ensure:

- permanent improvement of activities via maximum satisfaction of customers, employees, owners, and society;
- improvement of heat supply management;
- energy savings and energy efficiency throughout the life cycle of services;
- growth of financial indicators – at reduction of costs;
- efficient control of business management at heat-supply enterprise;
- improved reliability of HS functioning.

### Acknowledgements

Present work is performed under grant funding of scientific research GNTE No 0044 Scientific Adviser Kagazbek Erenchinov.

### References

- [1] ISO 9001. Quality Management Systems. Requirements. International Standard [text]. Fourth revision. Introduced on 2008.
- [2] ISO 9000. Quality Management Systems. Fundamentals and Vocabulary. International Standard [text]. Third revision. Introduced on 2005.
- [3] ISO 9004. Management for Sustained Success of Organization. Quality Management Approach [text]. Third revision. Introduced on 2009, p. 56.

- [4] Mukhanov B.K., Bazil G.D., Adilova Sh.K.: Features of heating network as control object. Works of International Scientific-Practical Conference "Information and Telecommunication Technology: Education, Science, Practice". Volume II, Almaty 2012, pp. 133-135.
- [5] Ogvozdin V.E.: Quality Management. Basic Theory and Practice. M.: Business and Service, 2002.
- [6] Serenkov P.S.: Quality Management Methods. Methodology of Describing a Process Network, BNTU, 2006.
- [7] Shalaginova Z.I.: Methods of analyzing the regime management and their application for quality assessment of district heating systems. Thermal Engineering, 2012, No 5, pp. 63-68.
- [8] www.rosteplu.ru

#### Nigina Toktasynova

e-mail: nigina\_1992\_02\_07@mail.ru

Nigina Toktasynova is a second-year master of automation and control, Faculty of Engineering Cybernetics, University of Energy and Communication.



#### M.Sc. Gulmira D. Bazil

e-mail: bazil\_g@kazntu.kz, bazil\_g@bk.ru

Gulmira D. Bazil conducts research in the control of district heating. She has 4 research publications. She is a second-year doctoral student of the Ph.D. doctor's department of Kazakh National Technical University in "Automation and Control". The theme of her work is "Research and development energy efficient informational and analytical system of heat supply control for the cities of Kazakhstan".



#### M.Sc. Shinar Adilova

e-mail: shinar82@mail.ru

Shinar Adilova is a third-year doctoral student of the Ph.D. doctor's department of Kazakh National Technical University in "Automation and Control".



otrzymano/received: 21.10.2013

przyjęto do druku/accepted: 12.02.2014