

Diagnostic tests of the ACC radar system

Michał Filipiak, Jarosław Jajczyk
Poznań University of Technology
60–965 Poznań, ul. Piotrowo 3a,
e-mail: {Michal.Filipiak; Jaroslaw.Jajczyk}@put.poznan.pl

The paper provides the characteristics of the construction and principle of operation of the adaptive cruise control system (ACC). The most important components of the system were presented and its cooperation with other electronic systems of the vehicle was discussed. An essential part of the paper focuses on diagnostic tests which were conducted on a model ACC system. The article presents the diagnostic device used during the tests and the characteristics of the tested system. During the diagnostic tests, the correctness of the ACC system communication with other systems was verified. The operation of the ACC manipulator push buttons was tested. Voltage and current values important for the proper performance of the system were read. The last part of the tests served the purpose of verification of the signals related to the current settings and condition of the ACC system.

KEYWORDS: vehicle diagnostics, convenience systems, radar, ACC system

1. Introduction

Electronic computer systems have become an integral part of the development of the automotive industry in the 21st century. Mechanical engine control was replaced by electromechanical microprocessor controlled controllers, which precisely select the fuel dose based on signals from many sensors and executive components. This way, fuel is saved and more ecological engines are obtained. At present, vehicles are provided with systems, whose function is to improve safety and comfort of the driver of a vehicle. The active safety systems such as ABS (Anti-Lock Braking System) or its subsequent development into ESP (Electronic Stability Program) improve safety. While preventing the wheels from being locked, the ABS ensures vehicle control during the braking process. The ESP, owing to the fact that is provided with special sensors, enables monitoring of the direction of driving and prevention of dangerous oversteering or understeering phenomena. The system can also apply the braking force to a selected wheel without the driver's interference. What determines its effectiveness is the speed of operation [10, 11].

Development of convenience systems has also contributed to the improvement of safety on roads. Such solutions as automatic windscreen wipers, revers-

ing sensors or cameras facilitate the observation of the vehicle's surroundings by the driver. Automatic gearboxes allow for correct holding of the steering wheel and full concentration on driving. While travelling on long distances, automatic vehicle speed maintenance systems turn out to be useful. (cruise control). Systems of this type in their standard version control the engine in order to maintain the pre-set speed. Extended versions, especially in trucks (Scania Active Prediction), allow for prediction of the terrain slope by means of the GPS data [12]. The system allows for fuel savings by predicting the road topology. It increases the vehicle's speed before elevations and decreases the torque before the peak of the elevation, so as not to brake while driving down. The cruise control systems have developed in recent times owing to the far-range and short-range radars. The connection of the systems mentioned above allowed the adaptive cruise control to be created.

The ACC system, owing to the possibility of interference into the algorithm of control of the engine, the gear box and the safety systems may accelerate, decelerate or even bring a vehicle to a halt. The decision is made taking into consideration the position and speed of other object on the road. Such a solution relieves the driver of pressing the gas pedal and supports him by monitoring of the speed of the vehicle ahead. This function is particularly useful when the driver is fatigued, and their reaction time is much longer.

Complicated systems, which constitute part of the equipment of modern vehicles, require specialist tools for their operation and diagnostics. Also, the skills in using these tools are not without significance. This paper discusses the construction and principle of operation of the adaptive cruise control system and presents the results of diagnostic tests performed by means of the computerized diagnostics system.

2. Construction and operation of the ACC system

The function of the ACC system is the constant maintenance of the pre-set vehicle speed including the possibility of adaptation of the speed to the vehicles that move slower. The system relieves the driver of the constant speed change and allows for safe driving at a constant distance from the vehicle moving ahead. It is connected with the systems responsible for accelerating and braking of the vehicle. The construction of the ACC system is presented in Figure 1.

Having been activated by the driver, the ACC system operates automatically performing one of several functions. While switching on the system, the driver can set the maximum driving speed and the distances from the vehicle ahead. Other functions such as switching of the system from the traditional cruise control to automatic speed adjustment, acceleration, deceleration and braking are activated automatically. The cruise control function is supposed to maintain the

set speed in situations when there are no vehicles ahead, moving with a lower speed.

The response of the ACC system is initiated when the radar detects another vehicle moving with a lower speed. In such a case, a signal is transmitted to the engine controller with a request to decrease the torque, and if a further decrease in distance takes place, braking is activated by adjusting the control of the ESP system. Braking is performed by a gradual increase in pressure in the braking system until speed is adjusted to that of the vehicle moving ahead. The vehicle ahead is followed maintaining the constant distance which is proportionate to the speed. The distance established during the system initiation corresponds to the time needed to move to the place at which the vehicle ahead is found at a given moment.

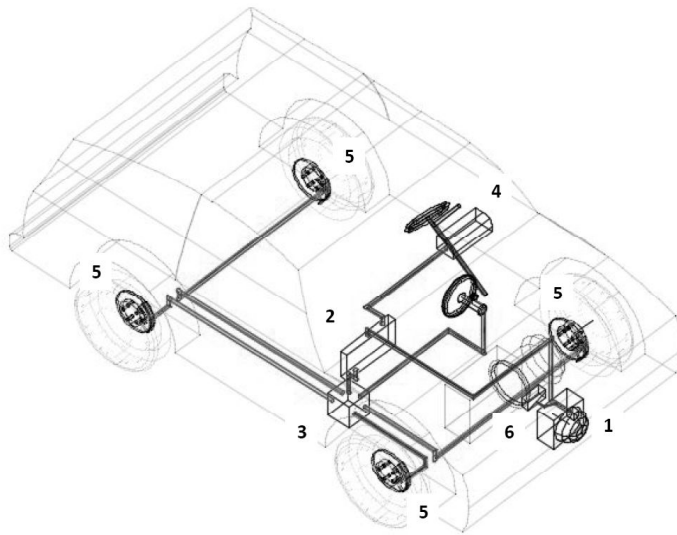

Fig. 1. The construction of the adaptive cruise control system (ACC) [1]: 1 – radar unit of the ACC system, 2 – engine controller, 3 – braking system with the ESP system, 4 – combined ACC system dashboard and operating elements, 5 – wheel speed sensors, 6 – automatic gearbox controller (option)

The operations of the system are illustrated in Figures 2–4. The vehicle which is equipped with the ACC system moves with a constant pre-set speed (Fig. 2) until it is identified by the vehicle ahead, moving with a lower speed (Fig. 3). In this situation, the ACC system interferes with the engine operation control and forces a reduction in the speed in order to avoid a collision (keep a safe distance). Figure 4 illustrates the situation in which the vehicle provided with the ACC system accelerates again to the pre-set speed (the vehicle ahead which moves slower disappears from the area monitored by the radar).

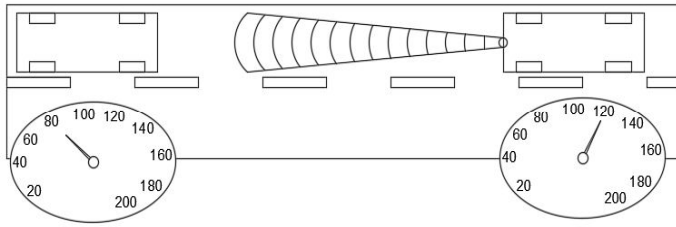

Fig. 2. Operation of the ACC system – driving with a constant speed without detecting any obstacle

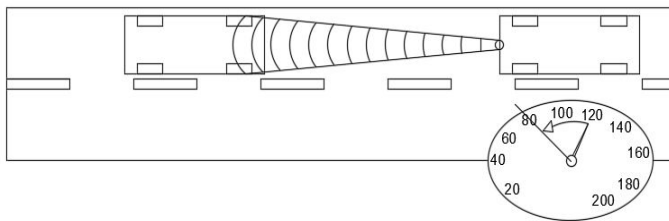

Fig. 3. Operation of the ACC system – detection of the slower vehicle and deceleration

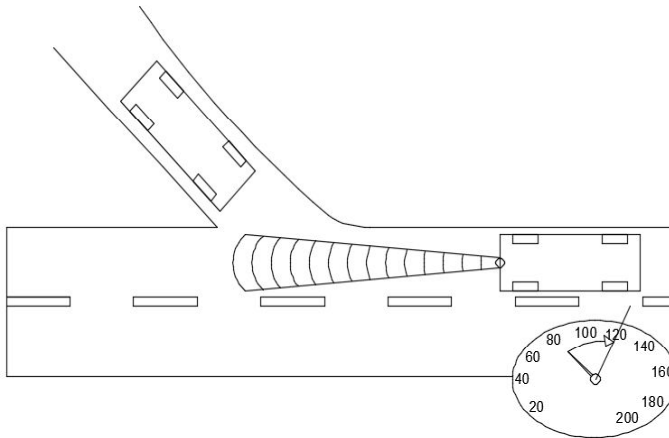

Fig. 4. Operation of the ACC system – no other vehicle within the range of the radar and acceleration to the preset speed

The most important element of the ACC system responsible for determination of the distance from another vehicle (object) is the long-range or medium-range radar. An advantage of the radar system over e.g. the light system is the more precise determination of the distance, especially during difficult weather conditions such as rain, snow or fog. Deflection of light depends on the surface on which the light falls. Dirty surfaces can significantly decrease the luminous

flux or disperse it completely. The radar is resistant to such interferences. The electromagnetic wave beam transmitted from the radar is deflected particularly well by all the electrically conductive materials, therefore, they are perfectly fit for measurement of the distance from vehicles.

The distance can be measured by the direct or indirect measurement of the time of travel of the electromagnetic wave beam.

In the case of the direct measurement, the following formula must be used (1):

$$\tau = \frac{2d}{c} \quad (1)$$

where: τ – time [s], d – distance to the preceding vehicle [m], c – velocity of electromagnetic wave propagation (300000 [km/s]).

The measurement is performed while driving the vehicle. In such a case, the Doppler effect occurs. Therefore, the frequency of the signal deflected from another vehicle will demonstrate a shift f_D in relation to the signal transmitted from the radar. The shift will depend on the difference between the vehicle speeds and can be calculated from the following formula (2):

$$f_D = \frac{-2f_c v_{rel}}{c} \quad (2)$$

where: f_c – carrier frequency of the radar signal, v_{rel} – relative speed.

Precise determination of the frequency shift has a significant effect on the accuracy of measurement of the distance between the objects.

The radar is mounted on the front part of the vehicle. The construction of the ACC radar unit is presented in Figure 5.

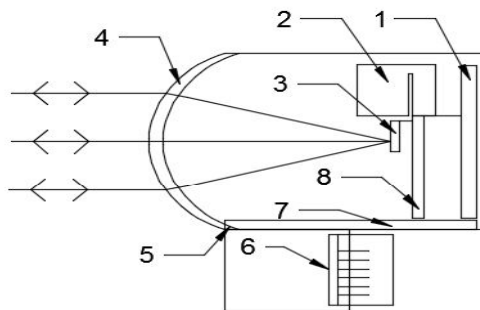

Rys. 5. Construction of the ACC radar: 1 – printed circuit board, 2 – generator body, 3 – source of radiation, 4 – lens, 5 – lens heating contact, 6, 7 – printed circuit, 8 – radar transmission–reception module (RTC) [1]

The radar lens is made of a special material resistant to weather conditions and mechanical damage. The radar is equipped with the heating system that prevents icing, which would cause additional signal attenuation.

The correct operation of the radar unit depends on its proper fixing as well as vertical and horizontal placement. The improper placement of the radar unit may cause reception of wrong signals, e.g. from a different traffic lane, or cause improper measurement of the distance or failure to detect a different vehicle. In order to obtain the representative and unambiguous results of measurements, the signal transmitted by the radar is about 9° wide and consists of three parallel beams (Fig. 6).

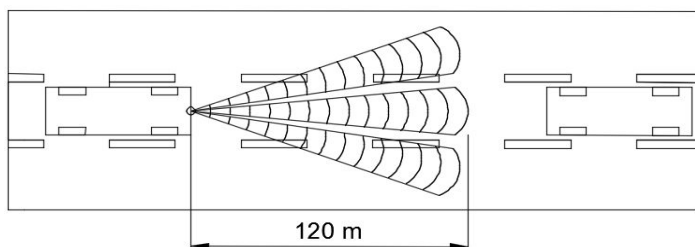

Fig. 6. Beams of the electromagnetic wave from the ACC radar

Table 1 lists the exemplary parameters of the radar manufactured by Bosch, used in the ACC system developed by this company.

Table 1. Parameters of an exemplary radar [1]

Name	Value	Unit
Range	2 – 120	m
Relative speed	-50 ÷ +50	(m/s)
Average transmitter power	1	mW
Resolution	0,85 (1,7)	m (m/s)
Frequency	76–77	GHz
Measuring unit	10	Hz
Bandwidth	about 200	Hz

The generation of the high frequency radiation by the radar (76–77 GHz) and its simultaneous emission in three wave beams, and then the reception and analysis of the waves deflected from an object all require very fast and precise electronic systems. These systems are provided with an expanded self-diagnosis module.

3. Diagnostics of the ACC system

The paper describes the conducted diagnostic tests of the ACC system installed in an estate passenger car – Volkswagen Passat 2.0 TDI. The vehicle was

equipped with the ACC system manufactured by TRW (3C0 907 567 M). As a diagnostic device, a modern KTS 570 diagnostic tester manufactured by Bosch was used. It enables, among other things, the reading and clearing of the error codes, switching off service controls, measuring of operating parameters in real time, viewing of signal runs in the oscilloscope mode. Owing to the wireless connection with a PC or notebook by means of the Bluetooth standard, mobility of tests is ensured to a certain extent. The diagnoscope fully operates the OBD (On-Board Diagnostic) standard and owing to the extended database, it enables the performance of tests of vehicles of different manufacturers [3, 5, 7, 8, and 9].

The tests allowed for checking of the operation of the ACC system. As the reading of the fault codes gave a negative result, the measurements of real parameters of the most important subassemblies of this system were carried out.

Figure 7 presents a screenshot of the diagnostic programme during the verification of the cooperation of the system with the subassemblies which are connected with the ACC system controller by means of the CAN (Controller Area Network) [2, 4, and 6]. The systems with which the ACC module communicates can include: the automatic gearbox controller, the multi-purpose indicator controller, the steering angle measurement system, the switch controller in the steering wheel column, the electric parking brake controller as well as the gate, allowing for communication with other networks (e.g. CAN for diagnosis). During the diagnosis, no other interferences in operation were observed (Fig. 7).



The screenshot shows the Bosch diagnostic software interface. At the top, it displays 'ES[tronic] 2.0' and 'BOSCH VWV 3831 / VW (VOLKSWAGEN) / Passat 2.0 TDI Variant 4Motion / 3C5'. Below this, there are three main menu items: 'Informacja o pojeździe', 'Diagnoza.', and 'Wyszukiwanie błędów'. The 'Diagnoza.' menu is selected. Underneath, it shows 'Regulacja prędk./odstępu / ACC 3.1' with a left-pointing arrow, and 'Wartości rzeczywiste'. The main content area is a table with the following rows:

Kom. ze sterownikiem przekładni Stan: w porządku
Komunikacja ze wskaźn. wielofunkc. Stan: w porządku
Komunikacja z czujn. kąta obr.kier. Stan: w porządku
Kom. z grupą przełączników kol.kier. Stan: w porządku
Komunikacja z el.hamulcem postojowym Stan: w porządku
Komunikacja z Gateway Stan: w porządku

Fig. 7. Data bus states during the verification of the cooperation of the ACC system with other modules

The next part of the diagnostic tests allowed the verification of push buttons and switches necessary for activation, deactivation and introduction of setpoints

and controls of the ACC system. The push buttons can be found nearby the steering wheel. The results read by means of the diagnoscope are presented in Figure 8. In the view of the window of the diagnostic programme, it is possible to notice that the first two values read in the same data set refer to the speeds of the selected wheels and are equal to 0 km/h. This is caused by the fact that the tests were performed when the vehicle was parked. During the diagnosis, the respective push buttons were pressed and their functioning as well as transmission of relevant messages to the ACC controller were all verified. No irregularities were found.

Regulacja prędk./odstępu / ACC 3.1	
Wartości rzeczywiste	
Prędkość koła lewy tył	0 km/h
Prędkość koła prawy tył	0 km/h
Przycisk SET tempomatu/ACC	Podzespół: nieruchomiony
Tempomat/ACC, przycisk Odstęp -	Podzespół: nieruchomiony
Tempomat/ACC, przycisk Odstęp +	Podzespół: nieruchomiony
Tempomat/ACC, przycisk RESUME	Podzespół: nieruchomiony
Tempomat/ACC, przycisk Prędkość +	Podzespół: nieruchomiony
Tempomat/ACC, przycisk Prędkość -	Podzespół: nieruchomiony
Tempomat/ACC, przycisk Cancel	Podzespół: nieruchomiony
Przełącznik tempomatu/ACC	Podzespół: wł.

Fig. 8. States of subassemblies while testing the functioning of the ACC manipulator push buttons

Further on during the tests, the electric signals related to the operation of the ACC system were read. The selected measured values that were read are presented in Figure 9.

The information about the levels of the respective voltages and values of currents allow the correctness of the system power supply to be assessed. In this case, no irregularities were noticed either.

In the last part of the tests, the parameters related to the current settings and the state of the ACC system were read (Fig. 10).

Zesp. czujn. ACC, napięcie str.plusa 4,4 V
Zesp.czujn.ACC, napięcie, str.minusa 4,4 V
Napięcie zasilania 13,8 V
Zesp.czujn.ACC,prąd rzecz.,str.plusa 0,274 A
Zesp.czujn.ACC,prąd rzecz.,str.minusa 0,017 A

Fig. 9. Values of the selected voltages and currents in the ACC system

ACC Funkcja: nieaktywna
Tempomat Funkcja: wyłączona
Tempomat/ACC, zapisana prędkość 40 km/h
Tempomat/ACC, zapisany odstęp 2,3 s
Temperatura sterownika 34 °C
Podgrzewanie obiektywu ACC 47 °C
Sygn.sterow.ACC, zadane przyspiesz. 2,919 m/s2
Odległość obiektu radarowego 1 0 m
Kąt nachylenia obiektu radarowego 1 0,0 °
Prędk.względna obiektu radarowego 1 0,0 km/h
Czujnik kąta skrętu kierownicy 0 °
Czujnik szybkości zarzucania pojazdu -0,14 %/s

Fig. 10. Values of the selected signals in the ACC system read during the diagnosis

The status of the ACC system (on/off), the correctness of saving of the pre-set speed of movement of the vehicle and the distances behind the object moving ahead (in the form of the time interval) were all checked. The correctness of operation of the stabilisation system of the controller temperature and radar lens was verified. On top of this, the diagnostic device enabled the reading of such parameters as: vehicle acceleration, distances to the vehicle moving ahead, angle of inclination and relative speed of the radar object, steering angle and speed of vehicle skidding.

4. Summary

The adaptive cruise control system is, without any doubts, the system which has a positive effect on safety and comfort of travelling with vehicles equipped with it. Owing to the application of complex control systems that use microprocessor systems and technologically advanced sensors (radar), the system can respond in time to the appearing incentives and adapt the speed of the vehicle to another vehicle ahead in such a manner as to maintain the pre-set distance. Such sophisticated systems require the appropriate equipment for their diagnostics. In principle, only the testing devices which cooperate with computers are useful.

The paper presents a number of diagnostic tests of the selected ACC system. The system operated correctly and no errors were observed. The non-zero values of certain signals were reported, though, because of the lack of movement of the vehicle during the tests, zero values were expected. Such results could be caused by external disturbances as well as inaccuracy of measurements of the diagnostic device. For instance, it was observed that in spite of performance of tests on a vehicle brought to a halt, a non-zero signal from the vehicle skidding speed sensor was present.

On the one hand, the conducted tests allowed for the presentation of the capacity of the diagnostic device that was used, and on the other hand, they allowed for the verification of the status of the ACC system and the analysis of signals which can be read while testing the system.

References

- [1] Bosch Team, *Adaptacyjna regulacja prędkości jazdy ACC*, Wydawnictwa Komunikacji i Łączności, Warszawa 2005.
- [2] Filipiak M., Jajczyk J., Nawrowski R., Putz Ł.: *Systemy bezpieczeństwa czynnego i ich diagnostyka*, Poznan University of Technology Electrical Engineering Academic Journals, zeszyt 69, s. 219–226, Poznań, kwiecień 2012, s. 219–226.
- [3] Filipiak M., Jajczyk J., Nawrowski R., Putz Ł.: *Urządzenia diagnostyczne w pojazdach samochodowych*, Poznan University of Technology Electrical Engineering Academic Journals, zeszyt 69, Poznań, kwiecień 2012, s. 227–234.

- [4] Herner A., Riehl H.J., *Elektrotechnika i elektronika w pojazdach samochodowych*, Wydawnictwa Komunikacji i Łączności, Warszawa 2002.
- [5] KTS 570 User Manual.
- [6] Myszkowski S., *Poradnik serwisowy. Diagnostyka pokładowa. Standard OBD II/EObD, Instalator Polski*, Warszawa 5/2003.
- [7] Schmidgall R., Zimmermann W., *Magistrale wymiany danych w pojazdach. Protokoły i standardy*, Wydawnictwa Komunikacji i Łączności, Warszawa 2008.
- [8] Sitek K., Syta S., *Pojazdy samochodowe. Badania stanowiskowe i diagnostyka*, Wydawnictwa Komunikacji i Łączności, Warszawa 2011.
- [9] Trzeciak K., *Diagnostyka samochodów osobowych*, Wydawnictwa Komunikacji i Łączności, Warszawa 2010.
- [10] *Konwencjonalne i elektroniczne układy hamulcowe*, Praca zbiorowa, WKŁ 2006.
- [11] *Układ stabilizacji toru jazdy*, Praca zbiorowa, WKŁ 2000.
- [12] <http://www.scania.pl/>, dostęp: 2016-01-14.

(Received: 21. 10. 2016, revised: 8. 11. 2016)