

## THE IMPACT OF ENTREPRENEURSHIP EDUCATION ON ENTREPRENEURIAL INTENTION: THE UAE CONTEXT

Khalifa A.H., Dhiyf M.M.\*

**Abstract:** Entrepreneurial intention (EI) is a key construct in research on new ventures creation. However, neither a clear or consistent definition nor a uniform way to measure entrepreneurial intention has yet emerged. Furthermore, no unanimity was observed about antecedents of this concept. Furthermore, the relationship between entrepreneurial education (EE) programs and students' entrepreneurial intentions using the Theory of Planned Behavior (TPB) has not been so widely studied, although this line of research is gaining momentum. The aim of this research is to explore the impact of entrepreneurial education on Entrepreneurial intention in the UAE context using the Theory of Planned Behavior. 400 students constitute the sample. Results of Structural Equations Modeling show that EE does not affect entrepreneurial intention. Results show that the entrepreneurial intention is very low among students of the UAE. Entrepreneurial Education is not working well to generate high entrepreneurial intention in the UAE context. We can explain this phenomenon by the very remarkable lack of academic programs totally dedicated to entrepreneurship and by the comfortable economic and social level of the UAE citizens.

**Key words:** TPB, entrepreneurial intention, Structural Equations Modeling

DOI: 10.17512/pjms.2016.14.1.11

*Article's history:*

*Received* May 17, 2016; *Revised* July 18, 2016; *Accepted* September 17, 2016

### Introduction

Entrepreneurship occupies an increasingly important place in modern economies since it is the main source of wealth and fight against unemployment. Thus, the similarities and differences between countries are based, in essence, on differences in employment rates and new business creation. Moreover, entrepreneurship as a field of research has considerable importance from an economic, social and even political point of view (Ladyga, 2015).

Entrepreneurial intent (EI) is the first act in the entrepreneurial process. It could be defined as a "Self-acknowledged conviction by individuals that they intend to set up a new business venture and consciously plan to do so at some point in the future" (Thompson, 2009). EI summarizes the willingness of a person to create his own enterprise (Fayolle et al., 2006), and can be explained by several factors. In this context, entrepreneurship education (EE) has evolved to become a prominent field. Actually, a successful entrepreneurship is positively affected by the dispositions, skills and competences of the entrepreneur. These dispositions,

---

\* **Ali Hadj Khalifa**, PhD, Assistant Professor, **Mohamed Mahjoub Dhiyf**, PhD, Associate Professor, Emirates College of Technology, Abu Dhabi – UAE

✉ Corresponding author: dhiyfmoahmed@yahoo.fr

skills and competences can be shaped by education (Illes et al., 2015). Numerous studies have shown that entrepreneurship education contributes to the development of entrepreneurial intention (Kuttim et al., 2014; Mat et al., 2015; Valliere, 2015; Sondari, 2014; Fayolle et al., 2006). However, the content and context of entrepreneurship education vary between universities, countries and regions. Consequently, many authors proposed a common framework based on the TPB proposed by Ajzen (1991) to assess change in student intention toward entrepreneurship.

The question here is to what extent EE contributes to the development of EI?

### Literature Review

Three theories could eventually form the theoretical framework for the study of entrepreneurial intention: Self-efficacy Theory of Bandura (1986), Valence – Instrumentality – Expectation Theory of Vroom (1995), and finally the Theory of Planned Behavior of Ajzen (1991).

The theory of self-efficacy is mainly applied to the analysis of career choices (Song and Chon, 2012). Therefore, it seems so to be insufficient and "incomplete" to predict alone the intention. As for the second theory, it's basically a motivation theory which does not take explicit account of the influence of contextual variables (Turabik and Baskan, 2015). However, it seems appropriate to adopt the Theory of Planned Behavior of Ajzen (1991) as a theoretical framework for studying EI. The TPB can be used to study and predict different kinds of human intentions to behave in a certain way (Halder et al. 2016; Paul et al., 2016; Thorhauge et al., 2016; Rowe et al., 2016; Kuttim et al., 2014). The theory has been also applied in entrepreneurial studies (Krueger et al., 2000; Autio et al., 2001; Gird and Bagraim, 2008; Leroy et al., 2008; Leroy et al., 2009; Nishimura and Tristán, 2011).

Actually, this theory perfectly contains and encompasses entrepreneurial intention, as a cognitive process where the will of the individual is combined with environmental factors (Ajzen, 1991). Three types of antecedents were identified by the theory of planned behaviour: (1) attitude or desire toward proposed behaviour; (2) social and subjective norms which take into account other people's opinions (especially opinions of influential persons) of the proposed behaviour; and (3) perceived control or feasibility of the proposed behaviour. These variables are supposed to positively affect the entrepreneurial intention (Krueger et al. 2000; Wu and Wu, 2008; Gird and Bagraim, 2008; Kuttim et al., 2014; Sondari, 2014; Valliere, 2015).

*H1a: There is a positive relationship between attitudes towards entrepreneurial behaviour and entrepreneurial intention.*

*H1b: There is a positive relationship between subjective norms and entrepreneurial intention.*

*H1c: There is a positive relationship between perceived behavioral control and entrepreneurial intention.*

The theory of planned behavior offers also enormous potential for entrepreneurship researchers interested in the impact of entrepreneurship education on the intentions of individuals. In its strict level, entrepreneurship education has a strong potential to enable youth to gain skills and generate their own skilled jobs and prepare them to be self-employed and owner of a new venture (Premand et al., 2016). At a broader level, entrepreneurship education can be placed in a wider context when by preparing not only a potential entrepreneur but also a person who pursues entrepreneurship and innovation as an employee (Gibb, 2002).

The relationship between entrepreneurial education programs and students' entrepreneurial intentions using TPB is gaining the interest of academics and professionals (Izquierdo and Buelens, 2008; Lüthje and Franke, 2003; Kolvereid and Moens, 1997; Souitaris et al., 2007; Fayolle et al., 2006). With few exceptional research (Von Graevenitz et al., 2010; Oosterbeek et al., 2010), education in general is confirmed to have a positive impact on entrepreneurship (Kuttim et al., 2014). It plays a moderator role on the three cognitive antecedents of entrepreneurial intention: attitudes, subjective norms and perceived behavioral control (Kuttim et al., 2014; Mat et al., 2015; Valliere, 2015; Sondari, 2014). According to Maresh et al., (2015), EE will first strengthen students' positive attitudes on EI. Second, the more students know about entrepreneurship, the clearer will be their decisions which become less reliant on their social reference groups. Third, EE aims to help students develop the skills and competences to seize entrepreneurial opportunities. Consequently, students become more confident in their ability to control their entrepreneurial behavior, which in turn strengthens the EI.

*H2a: the greater the extent of EE, the stronger the positive impact of attitudes on EI.*

*H2a: The greater the extent of EE, the weaker the positive impact of subjective norms on EI.*

*H2c: The greater the extent of EE, the higher the positive impact of perceived behavioral control on EI.*

EE is also seen as a strong antecedent of EI. This relationship is supported by two theoretical frameworks: Human Capital Theory (Becker, 1964) and Entrepreneurial Self-efficacy (Bae et al., 2014). Human capital theory focuses on skills and knowledge that individuals acquire through investment in schooling, training and other type of experiences strengthening the entrepreneurial intention.

A meta-analysis by Martin (2014) finds that EE is highly associated with EI. As for Entrepreneurial Self-Efficacy, it refers to the individual's belief that he or she is capable of successfully performing the various roles and tasks of entrepreneurship (Chen, 2010). He considered entrepreneurial self-efficacy as a positive moderator of the relationship between EE and EI.

*H3a: Entrepreneurship education affects positively entrepreneurial intention.*

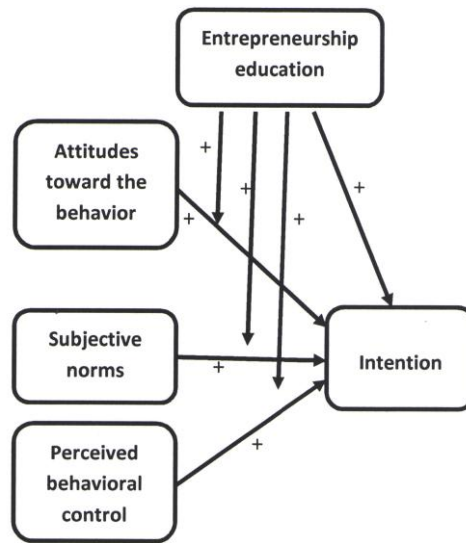

Figure 1. Conceptual model of entrepreneurial intention

### Research Methodology

This study was carried out through a survey method using questionnaire as the main data collection instrument. The sample consists of 400 students from 2 different programs business administration and Media (200 each sub-sample). The students of BA followed at least one course of entrepreneurship; however media students did not receive any.

Entrepreneurial Intention, as independent variable, was measured with a 5-point Likert scale, starting from (1) strongly disagree to (5) strongly agree. This measure was developed by Valliere (2015) who presented a new scale to address shortcomings of existing measures. According to him, previous scales have confounded intent with beliefs, attitudes, and expectations, contrary to the assumptions of the TPB adopted in this research. Also, previous measures ignore the effectual logic of intent. The final scale is constituted of 9 items.

The measurement of Attitudes was highly inspired from Ajzen's work and reflecting the respondent's attitudes toward entrepreneurship. This measure was a 5-Likert point scale and composed of 4 items.

The measurement of Subjective Norms is also a 5-Likert point scale capturing the social norms regarding entrepreneurship. These norms are varying from (1) highly negative to (5) highly positive. This measure is adopted from Maresh et al., (2015). Perceived Behavioral Control was measured through 8 items adopted from the study of Maresh et al., (2015) in accordance with the construct of locus of control scale by Levenson (1973).

To test the veracity of our hypotheses we are referring to the Structural Equations Modelling. Structural equation modelling is a multivariate statistical analysis

technique that is used to analyse structural relationships. This technique is the combination of factor analysis and multiple regression analysis, and it is used to analyse the structural relationship between measured variables and latent constructs.

### Results Discussion

The first set of results concerns the verification of the quality of the measuring instruments of all variables. The results of the exploratory factor analysis show good internal consistency of the different measurement scales: Cronbach's alpha is very significant for all variables (close to 1). In addition, the results of the Principal Component Analysis shows a great ability of items retained to explain the total variance of the associated variables. The internal consistency remains confirmed through the Confirmatory Factor Analysis as the RHO of Joreskog is sufficiently high for all variables.

**Table 1. Measurement instruments quality**

	ALPHA OF CRONBACK	% VARIANCE	RHO OF JORESKOG
INTENTION	0.89	78%	0.8
ATTITUDES	0.9	81%	0.88
SUBJECTIVE NORMS	0.78	77%	0.7
PERCEIVED BEHA. CONT	0.88	85%	0.87

Before interpreting the causal structure, it is necessary to check the measurement model for both samples: students who have taken at least one course in entrepreneurship and those who have not taken any.

**Table 2. The model fit indices**

	MODEL 1	MODEL2
CMINDF	2.899	2.87
GFI	0.901	0.9
CFI	0.9	0.91
NFI	0.899	0.91
RMSEA	0.049	0.05
AIC	203.235	202.333
ECVI	2.254	2.326

The adjustment indices show a good fit of both tested models with empirical data. The ratio Chi-Square / DF is less than 3, the strictest level. GFI is greater than the strictest value of 0.9. The RMSEA is below the threshold of 0.05. Moreover, the CAIC and ECVI of tested models are lower than the saturated models. The CFI and NFI exceed the strict threshold of 0.9. All values associated with the fit indexes are satisfactory. Both models are sufficiently acceptable. This leads to the conclusion that entrepreneurship education has no real effect on the entrepreneurial

intention. For this reason, we will perform the structural analysis combining the two samples. The objective here is only to verify the validity of TPB in the UAE context.

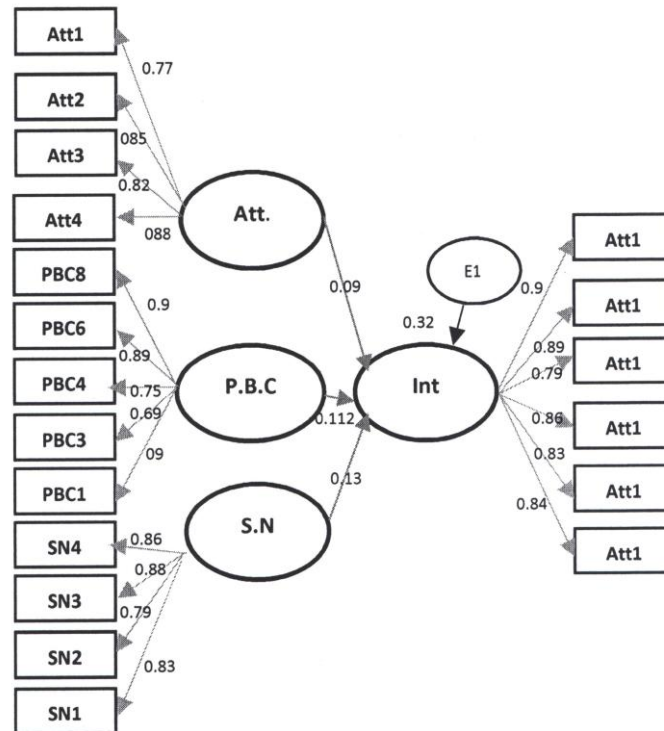

Figure 2. The structural model of entrepreneurial intention

Although significant ( $CR > 1.96$ ), the effect of the antecedents on the entrepreneurial intention is very limited ( $\beta$  very low). We can so conclude that the first hypotheses (H1a, H1b and H1c) are confirmed, where variables related to the moderator impact of education are not confirmed. Also, H3 is not confirmed as education doesn't have any effect of entrepreneurial intention.

**Discussion**

Results show that the entrepreneurial intention is very low among students of the UAE. Entrepreneurial Education is not working well to generate high entrepreneurial intention in the UAE context. Even stranger, this finding is in line with the findings of Von Graevenitz et al. (2010) and Oosterbeek et al. (2010). Results can first be explained by the very remarkable lack of academic programs totally dedicated to entrepreneurship. Local universities are settling for a very limited number of courses for a discipline that is gaining in scope and popularity across the worldwide.

This result can be also explained by the comfortable economic and social level of the UAE citizens. Indeed, a very favourable economic climate with an annual growth rate exceeding the 3% helps create jobs continuously. The unemployment issue is not therefore raised in the minds of Emirati youth. For them, the state is responsible for their employment. Aware of this state of mind, the UAE authorities are launching proactive initiatives essentially looking at the encouragement of entrepreneurship and private employment in line with the strategic vision 2020-2030.

### Conclusion

This research was carried out on a random sample of students of one of UAE universities in which entrepreneurship education is not very elaborated and condensed. This fact does not allow to generalize the findings to the entire UAE population of students.

Although the impact of education on entrepreneurial intention is not confirmed, this research suggests that EI is generally resulted from three main variables: attitudes towards entrepreneurship, subjective norms and perceived behavioral control. However, restudy this model in new context where the education of entrepreneurship is much elaborated seems very interesting.

Our finding may be a guideline for UAE authorities willing to develop entrepreneurship among national students under the 2030 economic vision.

UAE authorities, such as ministry of higher education, should focus on entrepreneurial education by diversifying programs and courses supporting entrepreneurship. Actually, one of the strategic objectives of UAE universities include creation of entrepreneurial intention and development of skills and competencies in the field of entrepreneurship. Teaching and learning methods should also be revised to enhance student participation and commitment.

### References

- Ajzen I., 1991, *The Theory of Planned Behaviour*, "Organizational Behavior".
- Autio E., Keeley R., Klofston M.P.G., May M., 2001, *Entrepreneurial intent among students in Scandinavia and in the USA*, "Enterprise Innovation Management Studies", 2.
- Bandura A., 1986, *Social foundations of thought and action: a social cognitive theory*, Prentice-Hall, Englewood Cliffs.
- Bae T., Miao C., Fiet J., 2014, *The relationship between entrepreneurship education and entrepreneurial intentions: a meta-analysis review*, "Enterprise Theory and Practice", 38.
- Becker G., 1964, *Human capital: A theoretical and Empirical analysis, with special reference to education*, New York: National Bureau of Economic Research.
- Chen Y., 2010, *Does entrepreneurship education matter to students' entrepreneurial intention? A Chinese perspective*, [In:] Second International Conference on Information Science and Engineering, China.



- Fayolle A., Gailly B., Lassas-Clerc N., 2006, *Assessing the impact of entrepreneurship education programmes: a new methodology*, "Journal of European Industrial Training", 30(9).
- Gibb A., 2002, *In pursuit of a new "enterprise" and "entrepreneurship" paradigm for learning: creative destruction, new values, new ways of doing things and new combinations of knowledge*, "International Journal of Management Review", 4(3).
- Gird A., Bagraim J., 2008, *The theory of planned behavior as predictor of entrepreneurial intent amongst final-year university students*, "South Africa Journal of Psychology", 38(4).
- Halder P., Pietarinen J., Havu-Nuutinen S., 2016, *The Theory of Planned Behavior model and students' intentions to use bioenergy: A cross-cultural perspective*, "Renewable Energy", 89.
- Illes Cs.B., Dunny A., Jelonek D., 2015, *The entrepreneurship in Poland and in Hungary: Future Entrepreneurs education perspective*, "Polish Journal of Management Studies", 12(1).
- Izquierdo E., Buelens M., 2008, *Competing models of entrepreneurial intentions: the influence of entrepreneurial self-efficacy and attitudes*, [In:] *Internationalizing Entrepreneurship Education and Training*, Ohio, USA.
- Kolvereid L., Moen O., 1997, *Entrepreneurship among business graduates: does a major in entrepreneurship make a difference?*, "Journal of European Industrial Training".
- Krueger N., Reilly M., Carsrud A., 2000, *Competing models of entrepreneurial intentions*, "Journal of Business Venture", 15.
- Kuttim M., Kallaste M., Venesaar U., Kiis A., 2014, *Entrepreneurship education at university level and students' entrepreneurial intentions*, "Contemporary Issues in Business, Management and Education".
- Ladyga E., 2015, *Entrepreneurship as a basis of Self-management on the way to career*, "Polish Journal of Management Studies", 12(1).
- Leroy H., Manigart M., Meuleman M., 2008, *The planned decision to transfer an entrepreneurial country*, [In:] *Academy of Management Conference*, Anaheim, USA.
- Leroy H., Meuleman M.S.L., Debrulle J., 2009, *Gender effect of entrepreneurial intentions: a TPB multi-group analysis at factor of indicator level*, [In:] *Academy of Management Annual Meeting*, Chicago, USA.
- Levenson H., 1973, *Reliability and validity of the I, P and C scales - a multidimensional view of locus of control*, American Psychological Association Convention, Montreal.
- Luthje C., Franke N., 2003, *The "making" of an entrepreneur: testing a model of entrepreneurial intention among engineering students at MIT*, "Research & Development Management", 32.
- Maresch D., Harms R., Kailer N., Wimmer-Wurm B., 2015, *The impact of entrepreneurship education on the entrepreneurial intention of students in science and engineering versus business studies universities programs*, "Technological Forecasting & Social Change".
- Martin L., 2014, *An emotion based approach to assessing entrepreneurial education*, "The International Journal of Management Education", 12.
- Mat S., Maat S., Mohd N., 2015, *Identifying factors that affecting the entrepreneurial intention among engineering technology students*, [In:] *2nd Global Conference on Business and Social Science*, Bali, Indonesia.



- Nishimura J., Tristan O., 2011, *Using the theory of planned behavior to predict nascent entrepreneurship*, "Ade Administracion ademia, Revista Latinoamericana", 46.
- Oosterbeek H., van Praag M., Ijsselstein A., 2010, *The impact of entrepreneurship education on entrepreneurship skills and motivation*, "European Economic Review", 54(3).
- Paul J., Modi A., Patel J., 2016, *Predicting green product consumption using theory of planned behavior and reasoned action*, "Journal of Retailing and Consumer Services", 29.
- Premand P., Brodmann S., Almeida R., 2016, *Entrepreneurship Education and entry into self-employment among university graduates*, "World Development", 77.
- Rowe R., Andrews E., Harris P., Armitage C., McKenna F., Norman P., 2016, *Identifying beliefs underlying pre-drivers' intentions to take risks: An application of the Theory of Planned Behaviour*, "Accident Analysis and Prevention", 89.
- Sondari M., 2014, *Is entrepreneurship education really needed? : examining the antecedent of entrepreneurial career intention*, [In:] The 5th Indonesia International Conference on Innovation, Entrepreneurship and Small Business.
- Song Z., Chon K., 2012, *General self-efficacy's affection career choice goals via vocational interests and person-job fit: A mediation model*, "International Journal of Hospitality Management".
- Souitaris V., Zerbinati S., Al-Laham A., 2007, *Do entrepreneurship programs raise entrepreneurial intention of science and engineering students?*, "Journal of Business Venturing".
- Thompson E.R., 2009, *Individual entrepreneurial intent: construct clarification and development of an international reliable metric*, "Entrepreneurship Theory and Practice", 33.
- Thorhaug M., Haustein S., Cherchi E., 2016, *Accounting for the Theory of Planned Behaviour in departure time choice*, "Transportation Research Part F", 38.
- Turabik T., Baskan G., 2015, *The importance of motivation theories in terms of education systems*, [In:] 5th World Conference on Learning, Teaching and Education Leadership, WCLTA 2015.
- Valliere D., 2015, *An effectuation measure of entrepreneurial intent*, [In:] The 6th Indonesia International Conference on Innovation and Small Business.
- Von Graevenitz G., Harhoff D., Weber R., 2010, *The effects of entrepreneurship education*, "Journal of Economic Behavior & Organization", 76(1).
- Vroom V., 1995, *Work and motivation*, San Francisco: Jossey-Bass Publishers.
- Wu S., L. Wu L., 2008, *The impact of higher education on entrepreneurial intentions of university students in China*, "Journal of Small Business and Enterprise Development", 15(4).

### WPLYW EDUKACJI PRZEDSIĘBIORCZOŚCI NA CHĘĆ PROWADZENIA PRZEDSIĘBIORSTWA W ZEA

**Streszczenie:** Dążenie do tworzenia nowych przedsiębiorstw i ich prowadzenia w wyniku właściwie prowadzonej edukacji w Zjednoczonych Emiratach Arabskich jest głównym aspektem przedstawionych w artykule badań. Dotychczas nie sformułowano w sposób jednoznaczny definicji „chęci prowadzenia przedsiębiorstwa”. Ponadto, nie zbadano dotychczas związku między programami edukacji w obszarze przedsiębiorczości z rosnącą tendencją do otwierania nowych przedsiębiorstw. Celem pracy było zbadanie wpływu

edukacji na chęć tworzenia nowych przedsiębiorstw przy wykorzystaniu Teorii Planowanego Zachowania. Próbę stanowiło 400 studentów. Wyniki modelowania równań strukturalnych pokazały, że procesy edukacyjne nie mają wpływu na to. Można wyjaśnić to zjawisko brakiem programów akademickich całkowicie poświęconych przedsiębiorczości i komfortowym poziomem życia ZEA, co nie zmusza ich do takich działań.

**Słowa kluczowe:** teoria planowanego zachowania, chęć prowadzenia przedsiębiorstwa, modelowanie równań strukturalnych

### 創業教育對創業意識的影響：阿聯酋的背景

**摘要：**創業意向（EI）是新創企業研究的一個重要結構。然而，既沒有明確或一致的定義，也沒有一個統一的方法來衡量企業家的意圖。此外，對於這個概念的前提，沒有觀察到一致。此外，企業家教育（EE）計劃和學生的企業家意圖使用計劃行為理論（TPB）之間的關係沒有如此廣泛的研究，雖然這一線的研究正在獲得動力。這項研究的目的是探討企業家教育對企業家意向在阿聯酋上下文使用計劃行為理論的影響。400名學生構成了樣本。結構方程的結果建模顯示EE不影響企業家意圖。結果表明，阿聯酋學生的創業意向非常低。創業教育不能在阿聯酋創造高企業意向。我們可以通過完全致力於創業的學術課程以及阿聯酋公民的舒適的經濟和社會水平來解釋這一現象。

**關鍵詞：**TPB，企業家意圖，結構方程模型