



Cent. Eur. J. Energ. Mater. 2019, 16(1): 91-104; DOI: 10.22211/cejem/105315

Article is available in PDF-format, in colour, at: <http://www.wydawnictwa.ipo.waw.pl/CEJEM.html>



Article is available under the Creative Commons Attribution-Noncommercial-NoDerivs 3.0 license CC BY-NC-ND 3.0.

Research paper

Research on the Critical Sizes for Detonation of Cube-shaped Transfer Charges

Xiang-run Zhao,^{1*} Shi-xin Jin,² Jin-hong Huang,²
Chao-zhen Li,¹ Li-wei Yan²

1) *State Key Laboratory of Explosion Science and Technology,
Beijing Institute of Technology, 5 South Zhongguancun Street,
Haidian District, 100081, Beijing, China*

2) *Liaoning North Huafeng Special Chemistry Co. Ltd.,
Beijing, China*

* *E-mail: zxr.chn@gmail.com*

Abstract: In order to obtain the minimum size, thickness and safe separation distance, for the cube-shaped transfer charges used in MEMS (micro-electromechanical system) explosive trains, an explosive train using a JO-9C(III) cube-shaped transfer charge was designed for experimental research. Detonation transfer experiments and detonation interruption experiments were conducted in turn. In initial experiments, the electric detonators were all in the armed position, but different thicknesses of the cube-shaped transfer charges were used. In the later experiments, the thickness of the transfer charges were unchanged, but the separation distances were different. The detonation path of the transfer charge under unsafe conditions was analyzed using the shock wave attenuation law. The results showed that the minimum thickness ranged from 0.2 mm to 0.4 mm, the minimum safe separation distance ranged from 0.4 mm to 0.6 mm; and the cube-shaped transfer charge is detonated by a shock wave from a steel gap rather than air clearance when the safe separation distance is less than the minimum threshold. The thickness design value of the cube-shaped transfer charge (JO-9C(III)) should not be less than 0.6 mm, and the safe separation distance design value of the MEMS explosive train should not be less than 1 mm.

Keywords: explosive train, transfer charge, shock wave sensitivity, minimum safe separation distance

Symbols and abbreviations

| | |
|-------|--|
| d | Diameter of the donor charge [mm] |
| HMX | 1,3,5,7-Tetranitro-1,3,5,7-tetrazocane |
| l | Distance from the incident point [mm] |
| p_l | Pressure where the distance from the incident point is l [GPa] |
| RDX | 1,3,5-Trinitro-1,3,5-triazinane |
| s | Safety separation distance [mm] |
| t | Thicknesses of the cube-shaped transfer charge [mm] |

1 Introduction

The explosive train is one of the most important parts of fuse design, and reliable transfer detonation and safety interruption detonation are the basic requirements of an explosive train [1]. Transfer charges serve as the connecting link between the preceding and following charges in an explosive train. It is an intermediate part of transferring and enlarging a detonation [2]. Miniaturization of an explosive train will play a critical role for meeting future military requirements considering the present demands for smaller, more efficient, and more “intelligent” systems [3].

In 2006, a MEMS (micro-electromechanical system) explosive train based on a cube-shaped transfer charge structure was reported [4, 5]. It includes three elements: the stationary input and output charge columns, both of which have parallel but non-collinear central axes, and the movable cube-shaped transfer charge, which has its longitudinal axis always perpendicular to the foregoing central axes. The cube-shaped transfer charge has axial misalignment and there is a steel gap (barrier) instead of a transfer charge between the input charge and the output charge when kept in the safe position. Thus, the output charge cannot be detonated by the input charge due to their axial misalignment and gap interruption. In the armed position, the input charge column is adjacent to the first end of the transfer charge, thereby initiating the transfer charge, and the second end of the transfer charge is adjacent to the output charge, thereby initiating the output charge. There are two vertical initiations in the process of detonation transfer. It involves corner effects and shock wave attenuation [6-10]. This is a safer design because the input and the output charges are physically separated and never in line. Therefore, this structure has been applied to a variety of MEMS fuses, and the detonation propagation characteristics of similar charges have been studied [11-14]. However, these studies did not consider the structure and assembly conditions of the explosive train. For reasons of reliability, in the armed position, cases where the cube-shaped transfer

charges are too thin to be detonated by the donor charge should be avoided. Therefore, the minimum thickness (t_{\min} , mm) must be determined. In addition, in order to ensure that the transfer charge in the safe position is not detonated by the accidental ignition of the donor charge, the design safety separation distance (s , mm, equal to the separation length of the two closest edges between the donor charge and the transfer charge) must be greater than the minimum safe separation distance (s_{\min} , mm). In the case of $s < s_{\min}$ the transfer charge will be detonated by the accidentally ignited donor charge in one of two possible paths. Therefore, it is necessary to determine which path will operate, which can provide a basis for the designer to improve the design.

2 Experimental

2.1 Experimental program

A simple explosive train sample was designed using a micro-scale electric detonator (donor charge), a booster (witness charge), and a cube-shaped transfer charge (receptor charge). The transfer charge was press loaded into the charge gap, which has the same thickness. The dimensions of the two end surfaces of the cube-shaped transfer charge are larger than the middle transmission section. This design allows the cube-shaped transfer charge to better accept the output energy from the electric detonator and further enlarge the output energy to detonate the booster. In order to simplify the experiments, the electric detonator was offset instead of moving the transfer charge to simulate the interruption process. A schematic of the structure of the explosive train sample is shown in Figure 1. In the schematic, there are two holes for the detonator in the detonator enclosure (5), which correspond to the two states of safe position and armed position. The diagram shows their positional relationship. The actual part has only one hole, because each part can only simulate one state for testing. The transfer charge was press loaded into the charge gap (3), and an inseparable subassembly was formed. This is illustrated as two separated parts for showing its outer shape.

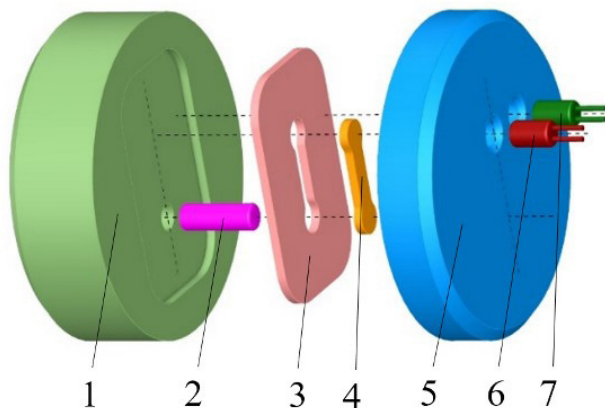

Figure 1. Schematic of the explosive train sample: 1 – booster enclosure, 2 – booster, 3 – charge gap, 4 – cube-shaped transfer charge, 5 – detonator enclosure, 6 – electric detonator (armed position), 7 – electric detonator (safe position)

The first set of experiments involved detonation transfer experiments. In this set of experiments, all electric detonators in the explosive train were in the armed position, but the thicknesses of the cube-shaped transfer charges (t , mm) were varied. The different thicknesses of the transfer charge were pressed into the corresponding thickness of the charge gap. In 2015, the author of this paper studied the MEMS explosive train using JO-9C(III) cube-shaped transfer charges, and found that the detonation reliably transferred step by step when $t = 0.8$ mm. However, variable thickness detonation transfer and variable separation distance detonation interruption have not been studied [15]. Therefore, beginning at $t = 0.6$ mm and decreasing each subsequent step by 0.2 mm until the transfer charge could not be detonated, the t_{min} was obtained.

Next set of experiments involved detonation interruption experiments. In this set of experiments, t was held constant (determined according to the detonation transfer experiments), but s was varied. Therefore, beginning at $s = 0$ mm and adding 0.2 mm at each subsequent step until the detonation was safely interrupted. The s_{min} was thus obtained.

2.2 Experimental elements and materials

Electric detonator size (shaped-charge concave output surface): diameter 2.5 mm; main charge: CL-20; output detonation pressure: 14.26 GPa (measured value, standard deviation in test value was 1.56). Manufacturer: Liaoning North Huafeng Special Chemistry Co. Ltd.

Main measuring equipment: H-type micro manganin piezoresistive sensor; MH4E constant current source with high-speed synchronous pulse; Tektronix TDS5054B digital phosphor oscilloscope. The measuring equipment below is the same as this, and will not be described again.

Transfer charge: authorized transfer charge JO-9C(III) (95 wt.% of submicron HMX + 5 wt.% of Viton); charge density: $1.7 \text{ g} \cdot \text{cm}^{-3}$ (90% theoretical density); output detonation pressure: 16.48 GPa (measured value, standard deviation in test value was 1.28). Manufacturer: North University of China.

Booster size: diameter 2.5 mm; main charge: JO9C (95 wt.% of micron HMX + 5 wt.% of Viton). Manufacturer: Liaoning North Huafeng Special Chemistry Co. Ltd.

Detonator enclosure and booster enclosure: super-hard aluminum 7A04.

Charge gap: high strength martensitic stainless steel 1Cr11Ni2W2MoV.

Charge way: position fixation press loaded.

Subassemblies of charge gap are shown in Figure 2. Each sample was secured by $4 \times \text{M4}$ screws.

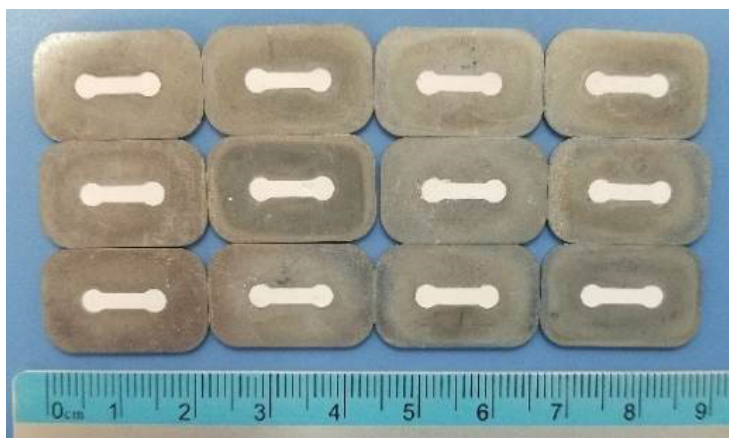

Figure 2. Sub-assemblies of the charge gap, assembled samples

3 Results and Discussion

3.1 Explosive train transfer experiments

Three sizes ($t = 0.6 \text{ mm}$, 0.4 mm and 0.2 mm) of cube-shaped transfer charges were pressed into the gap. In the process of sample preparation, press loading of 0.2 mm transfer charges in the gap was very difficult; the pass rate

was less than 20%. The quality defects of transfer charges, for example, attached to the mold, flaws, drop pieces, *etc.*, can occur owing to the cube-shaped transfer charge being too thin. These problems revealed that the press load technique had not been adapted to a charge of such small thickness.

The sample residues after the transfer experiment are shown in Figure 3, and experimental conditions and results are listed in Table 1. The experimental results from Figure 3 and Table 1 showed that the explosive train can transfer step by step when $t = 0.4$ mm and $t = 0.6$ mm, but the detonation failed to transfer when $t = 0.2$ mm. At the same time, the cube-shaped transfer charges were disintegrated by the action of the output energy of the electric detonators. The cause of failure was that the electric detonator did not initiate the transfer charge. All parts were intact except for the detonation shock imprint. The thickness value of the ‘failed to transfer’ test was obtained, and the testing of this group was complete.

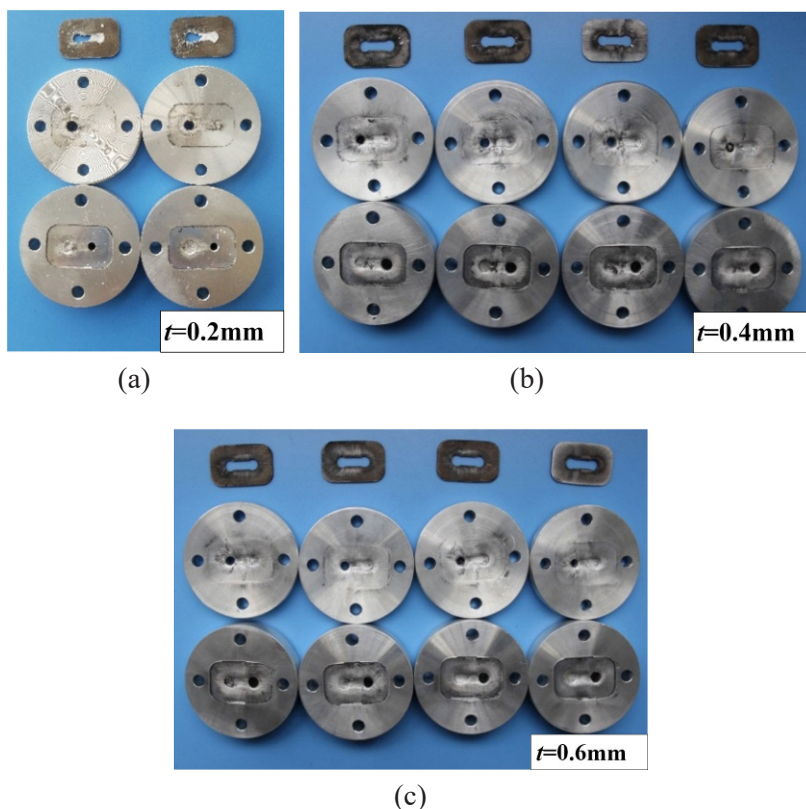

Figure 3. Sample residues after the transfer experiments

Table 1. Detonation transfer experiment results

| t [mm] | Test number | Transfer charge weight [mg] | Detonated number ^a | Shock depth ^b [mm] |
|----------|-------------|-----------------------------|-------------------------------|-------------------------------|
| 0.6 | 10 | 26 ± 1 | 10 | 0.9 |
| 0.4 | 10 | 17 ± 1 | 10 | 0.6 |
| 0 | 2 | 8 ± 1 | 0 | 0 |

^a Detonated number refers to the whole explosive train that was reliably transferred, step by step (all charges were detonated); ^b Shock depth refers to the detonation shock imprint depth on the contact surface between the enclosure and the transfer charge, and are approximate values.

Since the threshold of detonation pressure of the transfer charge had not been provided in the references, a qualitative analysis method was used to analyze the explosive train transfer experiment results. Xu *et al.* [16] studied the detonation reaction zone length of small booster charges and found that the chemical reaction zone thickness of JO-9C is about 0.22 mm. Therefore, 0.2 mm JO-9C cannot complete the chemical reaction; in other words, 0.2 mm JO-9C cannot be detonated. Wang [17] reported the shock wave sensitivity of JO-9C as 10.08 mm; for JO-9C(III) (90% theoretical density) it is 9.15 mm. Clearly, the JO-9C has greater shock sensitivity than JO-9C(III). Therefore if 0.2 mm JO-9C cannot be detonated by a shock wave, then 0.2 mm JO-9C(III) will also fail to be detonated. Therefore, t_{\min} has a value between 0.2 mm and 0.4 mm.

3.2 Explosive train interruption experiments

According to the previous experiments, the detonation transfer has at least a 1.5 times margin when $t = 0.6$ mm. Hence, the thickness of the transfer charge in the detonation interruption experiments was 0.6 mm and the charge weight was 26 ± 1 mg.

The samples with different safe separation distances after detonation are shown in Figure 4. The experimental results showed that the cube-shaped transfer charges were detonated when $s = 0$ and 0.2 mm, and the boosters were also detonated by the transfer charges. Clearly, the detonation of explosive train is not safely interrupted when $s = 0$ mm and 0.2 mm. Two samples were detonated, and another two samples were interrupted with $s = 0.4$ mm. All of the samples were safely interrupted when $s = 0.6$ mm, and the transfer charges were intact. In the samples that were detonated, the metal gaps were broken due to the output of the detonator. Hence, s_{\min} has a value between 0.4 mm to 0.6 mm.

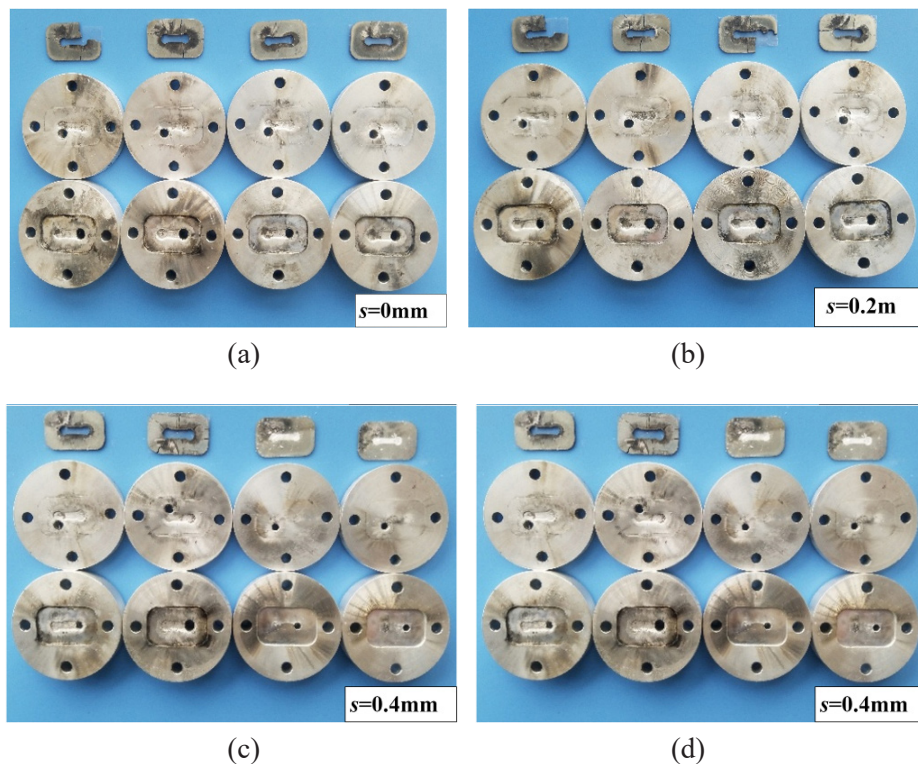

Figure 4. Sample residues after the detonation interruption experiments

The assembly of charge gap and booster enclosure is designed as a clearance fit, therefore, there is in fact an air clearance between the charge gap and the detonator enclosure, and its thickness is 0 mm to 0.08 mm. Considering these mechanical characteristics, in theory the transfer charge could be detonated by a shock wave, which could possibly come from the gap or air clearance. Two methods of pressure attenuation and propagation velocity are used to determine the detonation path. The location of the detonation interruption experiment is idealized and illustrated in Figure 5. The shock wave curves (dotted line) are illustrative in Figure 5, and only express the shock wave propagation path and the tendency for attenuation.

The output of the electric detonator is concentrated approximately at point “o” because of the concave shaped-charge (see Figure 5). Hence, the shock wave propagates outwards in the form of concentric circles around the point “o” in the gap and rapidly attenuates as the distance increases [18-21]. When the shock wave reaches the transfer charge surface, if the pressure of the shock wave

is greater than the detonation threshold of the transfer charge, the transfer charge will be detonated. Otherwise, the transfer charge will be safe.

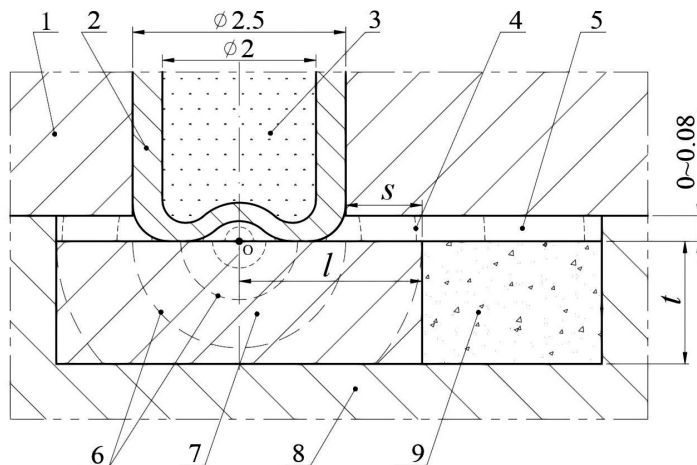

Figure 5. Detonation interruption experiments, location schematic: 1 – detonator enclosure, 2 – detonator case, 3 – detonator main charge, 4 – shock wave (in air clearance), 5 – air clearance, 6 – shock wave (in gap), 7 – gap, 8 – booster enclosure, 9 – cube-shaped transfer charge

Initially, it is assumed that the transfer charge is detonated by a shock wave coming from the “gap”. The shock wave sensitivities mentioned above were obtained by the small scale gap test (SSGT) [22, 23]. The SSGT involves detonating a standard donor charge which abuts a cylindrical polymethylmethacrylate (PMMA) attenuator (the “gap”), which in turn abuts the acceptor charge that is under test [24]. The shock wave generated by the donor charge is attenuated through the gap. The propagation shock wave then may or may not trigger the acceptor, depending on the level of attenuation. If the acceptor is detonated, a hole is created in the witness block. The gap thickness is then adjusted and the test repeated until a critical thickness (go/no-go) is obtained for the test sample as the acceptor charge. The critical gap thickness for which the acceptor has 50% probability of being detonated, marks the shock sensitivity of the acceptor [25, 26]. A uniform standard of donor charge is used when testing the shock wave sensitivity by the SSGT method. Consequently, Wang studied the mathematical model under the standard conditions, and presented a shock wave attenuation rule in the PMMA gap under

the standard methodology (the donor charge is cylindrical RDX with a density of $1.6 \text{ g}\cdot\text{cm}^{-3}$) as given in [27]:

$$p = 18.803e^{-0.186X} \quad (1)$$

where p is the pressure of the shock wave in the gap, in GPa, and X is the gap thickness (equal to the shock wave sensitivity value), in mm. From Equation 1, the pressure at which JO-9C(III) (90% theoretical density) is detonated can be calculated, with a probability of 50%, as $p = 6.35$ GPa.

Zhao *et al.* [28] studied the attenuation model of a shock wave in the gap and gave an attenuation rule for the shock wave under different conditions. The attenuation rule that matched the detonation interruption experiment conditions is as follows:

$$\frac{p_l}{p_0} = 1 - 0.9493 \frac{l}{d} + 0.3802 \left(\frac{l}{d}\right)^2 - 0.0563 \left(\frac{l}{d}\right)^3 \quad (2)$$

where p_l is the pressure, in GPa, where the distance from the incident point is l , in mm, in the steel gap, p_0 is the incident point pressure (equal to the output detonation pressure of the electric detonator in this experiment), in GPa, and d is the diameter of the donor charge (equal to the diameter of the main charge of the electric detonator, 2 mm, see Figure 5), in mm. Equation 2 can be used to calculate the shock wave pressure. These results are listed in Table 2.

Table 2. Shock wave pressure coming from the gap

| l [mm] | s [mm] | p_l [GPa] |
|----------|----------|-------------|
| 1.25 | 0 | 7.72 |
| 1.45 | 0.2 | 6.99 |
| 1.65 | 0.4 | 6.33 |
| 1.85 | 0.6 | 5.74 |

The relation between l and s is shown in Figure 5. Obviously, the shock wave sensitivity of JO-9C(III) is closest to $p_{1.65}$, according to the calculated results. This indicates that when $s = 0.4$ mm, the transfer charge will be detonated with 50% probability, and this is in good agreement with the experimental result.

Subsequently, it is assumed that the transfer charge is detonated by a shock wave coming from the “air clearance”. Xu *et al.* [29] studied the attenuation rule of detonation waves in air under micro-scale charge conditions, and gave the formula as follows:

$$p_l = p_0 e^{-\alpha l^\psi} \quad (3)$$

where α is the attenuation coefficient of the detonation products, in $\text{mm}^{-\psi}$, and ψ is the modification coefficient for pressure attenuation of the detonation products in a rarefaction medium. The author gave the values of the coefficient under different conditions. The values for $d = 2$ mm were not given, but the values listed are $\alpha = 1.932$, $\psi = 0.3766$ when $d = 3$ mm, and $\alpha = 4.662$, $\psi = 0.3826$ when $d = 1.5$ mm. The pressure for $d = 2$ mm is between these two diameters. Equation 3 can be used to calculate the shock wave pressure, and the results are listed in Table 3. From this result, it can be concluded that when the shock wave pressure is a value between 0.05 GPa and 1.38 GPa, the transfer charge will be detonated with a probability of 50%. This does not match the results from Equation 1 (6.35 GPa).

Table 3. Shock wave pressure coming from the air clearance

| l [mm] | p_l [GPa] | |
|----------|--------------|------------|
| | $d = 1.5$ mm | $d = 3$ mm |
| 1.25 | 0.089 | 1.746 |
| 1.45 | 0.066 | 1.546 |
| 1.65 | 0.050 | 1.383 |
| 1.85 | 0.039 | 1.248 |

In the condensed medium, there is a linear relationship between the shock wave velocity (D , $\text{km}\cdot\text{s}^{-1}$) and its post-wave particle velocity (u , $\text{km}\cdot\text{s}^{-1}$), over a fairly wide range of velocities [30]:

$$D = c_0 + \lambda u \quad (4)$$

where c_0 , in $\text{km}\cdot\text{s}^{-1}$, and λ , dimensionless, are Hugoniot parameters. For the case where the medium is stainless steel and $p < 190$ GPa, $c_0 = 4.58$ $\text{km}\cdot\text{s}^{-1}$ and $\lambda = 1.49$ [30]. In fact, post-wave particle velocity u is positively correlated with the pressure of the shock wave p . Therefore, $D > 4.6$ $\text{km}\cdot\text{s}^{-1}$. According to the Prandtl relation, the shock wave velocity (D' , $\text{km}\cdot\text{s}^{-1}$, approximation) in air can be obtained by the following equation [31]:

$$D' = c + u' \quad (5)$$

where c is the sonic velocity (≈ 0.34 $\text{km}\cdot\text{s}^{-1}$) and u' ($\text{km}\cdot\text{s}^{-1}$) is the post-wave particle velocity in air. Velocity u' is correlated with the shock wave pressure in air p' .

Yang [32] studied the detonating properties of energetic materials and gave $u' = 2.49 \text{ km}\cdot\text{s}^{-1}$ when $p' = 39.5 \text{ GPa}$. It can thus be calculated that $D' \approx 2.83 \text{ km}\cdot\text{s}^{-1}$ in this case. However, it is known from the above calculations that $p' < 1.38 \text{ GPa}$ under the interruption experimental conditions. Therefore, $u' < 2.49 \text{ km}\cdot\text{s}^{-1}$. In other words, $D' < 2.83 \text{ km}\cdot\text{s}^{-1}$. It is obvious that the shock wave in the gap reaches the transfer charge before the shock wave in the air.

Therefore, the above analysis shows that the cube-shaped transfer charge was detonated by the shock wave from the gap rather than the air clearance. This conclusion allowed us to recognize the actual detonation path.

4 Conclusions

From the experiments and analysis of the cube-shaped transfer charge in the explosive train, some conclusions were drawn (charge conditions: JO-9C(III), press loaded in steel gap, density $1.7 \text{ g}\cdot\text{cm}^{-3}$):

- (1) The t_{\min} has a value between 0.2 mm and 0.4 mm. Detonation could not transfer step by step in the explosive train if $t < t_{\min}$, because the cube-shaped transfer charge is too thin to be detonated by the donor charge. It is recommended that the cube-shaped transfer charge thickness be not less than 0.6 mm in the design of the MEMS explosive train.
- (2) The s_{\min} has a value between 0.4 mm and 0.6 mm. Detonation cannot be safely interrupted if $s < s_{\min}$, and the cube-shaped transfer charge will be detonated by the shock wave coming from the steel gap rather than the air clearance. It is recommended that the safe separation distance be not less than 1 mm in the design of the MEMS explosive train.

Because of its excellent characteristics, JO-9C(III) is a modern authorized transfer charge in China, and has been used in many micro-scale charges and explosive trains. Hence, the conclusions are equally valid in these fields.

References

- [1] Ye, Y.H. *Technology of Initiators and Pyrotechnics*. (in Chinese) Beijing Institute of Technology Press, Beijing, **2014**, pp. 102-106; ISBN 978-7-118-09309-4.
- [2] Wang, K.M.; Wen, Y.Q. *Design of Initiators and Pyrotechnics for Weapon Systems*. (in Chinese) National Defense Industry Press, Beijing, **2006**, pp. 263-265; ISBN 7-118-04105-X.
- [3] Schadow, K. MEMS Military Applications – RTO Task Group Summary.

- AIAA2004-6749, *Conference on Micro-Nano-Technologies CANEUS 2004*, California, USA **2004**.
- [4] Xu, X.C.; Jiao, Q.J.; Cao, X. Attenuation Regularity of Detonation Wave of Small Charge in PMMA. (in Chinese) *Chin. J. Energ. Mater. (Hanneng Cailiao)* **2009**, *17*(4): 431-435.
- [5] Li, S.C.; Feng, C.G.; Zhao, T.H. The Influence of the Angle of Convex Corner on the Effect of Detonation Waves. *Combust. Explos. Shock Waves* **1999**, *19*(4): 289-294.
- [6] Held, M. Detonation Wave's Corner Effects. (in Chinese) *Chin. J. Energ. Mater. (Hanneng Cailiao)* **2000**, *8*(1): 5-8.
- [7] Lu, J.P.; Christo, F.C.; Kennedy, D.L. Detonation Modelling of Corner-turning Shocks in PBXN-111. *Australasian Fluid Mechanics Conf., 15th*, Sydney, AUS **2004**.
- [8] Li, S.B.; Dong, Z.X.; Qi, Y.J.; Jiao, J.F. Numerical Simulation for Spread Decay of Blasting Shock Wave in Different Media. (in Chinese) *J. Vib. Shock (Zhendong Yu Chongji)* **2009**, *28*(7): 115-117.
- [9] Maurer, W. H.; Soto, G.H.; Hollingsworth, D.R. *Method for Utilizing a MEMS Safe Arm Device for Microdetonation*. Patent US 7007606B1, **2006**.
- [10] Robinson, C.H.; Wood, R.H.; Gelak, M.R.; Hollingsworth, D. *Micro-scale Firetrain for Ultra-miniature Electro-mechanical Safety and Arming Device*. Patent US 7069861B1, **2006**.
- [11] Li, X.G.; Jiao, Q.J.; Wen, Y.Q. Critical Characteristic of Detonation Propagation of Superfine Desensitized HMX Charge in Channel. (in Chinese) *Chin. J. Energ. Mater. (Hanneng Cailiao)* **2008**, *16*(4): 428-431.
- [12] Hu, F.; Liu, Y.C.; Wang, J.H.; Kai, W.U. Squeeze Charge Process and Booster Performance of HMX/CL-20-based Booster. (in Chinese) *Chin. J. Explos. Propellants (Huozhayao Xuebao)* **2013**, *36*(4): 87-90.
- [13] Zhang, S.M. Study on Characteristics of Initiation and Detonation Transfer for Micro-diameter Charge. (in Chinese) Ph.D. thesis, *North University of China*, **2009**.
- [14] Bao, B.L.; Yan, N.; Zhu, F. Research on the Influence of Charge Diameter upon the Output Pressure of Small-sized Explosives. *Cent. Eur. J. Energ. Mater.* **2015**, *12*(4): 623-635.
- [15] Zhao, X.R.; Sun, Y.C.; Yan, L.W.; Hao, Y.P.; Jin, S.X. Explosive Transfer Performance Study of a Flat-sheet Style and Micro-scale Explosive Train. (in Chinese) *Chin. J. Energ. Mater. (Hanneng Cailiao)* **2015**, *23*(2): 184-188.
- [16] Xu, X.C.; Jiao, Q.J.; Qin, G.S.; Chu, E.Y.; Wang, K.X.; Jin, Z.X. Study on Reaction Zone Length of Small Booster Charges. (in Chinese) *Initiators Pyrotech.* **2009**, (5): 35-38.
- [17] Wang, K.M. *Engineering of Initiators and Pyrotechnics*. (in Chinese) National Defense Industry Press, Beijing, **2014**, pp. 429; ISBN 978-7-118-09802-0.
- [18] Zhao, H.X.; Xu, X.C.; Hu, S.Q.; Zhang, S.M.; Jiao, Q.J. Attenuation Model of Shock Wave in Different Materials Gap. (in Chinese) *Chin. J. Explos. Propellants*

- (*Huozhayao Xuebao*) **2011**, 34(6): 84-87.
- [19] Wang, E.; Shukla, A. Analytical and Experimental Evaluation of Energies During Shock Wave Loading. *Int. J. Impact Eng.* **2010**, 37(12): 1188-1196.
- [20] Nurick, G.N.; Mahoi, S.; Langdon, G.S. The Response of Plates Subjected to Loading Arising from the Detonation of Different Shapes of Plastic Explosive. *Int. J. Impact Eng.* **2016**, 89: 102-113.
- [21] Ayisit, O. The Influence of Asymmetries in Shaped Charge Performance. *Int. J. Impact Eng.* **2008**, 35(12): 1399-1404.
- [22] *Safety and Performance Tests for the Qualification of Explosives (High Explosives, Propellants, and Pyrotechnics)*. MIL-STD-1715A: Method 1042. Department of Defense Test Method Standard, **2001**.
- [23] *Test Method of Safety for Booster Explosive. Part 1: Small Scale Gap Test*. GJB 2178.1A-2005, National Military Standard of the People's Republic of China, **2005**.
- [24] Bourne, N.K.; Cooper, G.A.; Burley, S.J.; Fung, V; Hollands, R. Re-calibration of the UK Large Scale Gap Test. *Propellants Explos. Pyrotech.* **2005**, 30(3): 196-198.
- [25] Keshavarz, M.H.; Motamedoshariati, H.; Pouretedal, H.R.; Tehrani, M.K.; Semnani, A. Prediction of Shock Sensitivity of Explosives Based on Small-scale Gap Test. *J. Hazard. Mater.* **2007**, 145(1): 109-112.
- [26] Kim, B; Yoh, J.J.; Lee, J.; Park, J. A Detailed Numerical Calibration of Shock Pressure in the Gap Test Configuration for Characterizing Non-ideal Energetic Materials. *AIAA/SAE/ASEE Joint Propulsion Conf., 51st*, Orlando, FL **2015**.
- [27] Wang, Z.S.; Liu, Y.C.; Zheng, M.; Zhang, J.L. Study on Attenuating Model of Detonation Shock Wave in the PMMA Gap. (in Chinese) *J. Basic Sci. Eng.* **2001**, 9(4): 316-319.
- [28] Zhao, H.X.; Xu, X.C.; Hu, S.Q.; Zhang, S.M.; Jiao, Q.J. Attenuation Model of Shock Wave in Different Materials Gap. (in Chinese) *Chin. J. Explos. Propellants (Huozhayao Xuebao)* **2011**, 34(6): 84-87.
- [29] Xu, X.C.; Jiao, Q.J.; Cao, X.; Hu, S.Q.; Zhao, H.X. Attenuation Regularity of Detonation Wave of Small Charge in PMMA. (in Chinese) *Chin. J. Energ. Mater. (Hanneng Cailiao)* **2009**, 17(4): 431-435.
- [30] *LASL Shock Hugoniot Data*. (Marsh S.P., Ed.) University of California Press, Berkeley, Los Angeles, London, **1980**; ISBN 0-520-04008-2.
- [31] Li, W.X. *One-dimensional Nonsteady Flow and Shock Waves*. National Defense Industry Press, Beijing, **2003**, pp. 206-212; ISBN 7-118-02869-X.
- [32] Yang, L.C. Improved Methodology for Estimation of Detonating Properties and Detonability of Energetic Materials. *AIAA/SAE/ASEE Joint Propulsion Conf., 53rd*, Atlanta, GA **2017**.

Received: May 21, 2018

Revised: October 24, 2018

First published online: March 7, 2019