

Marta WOCH  
 Marcin KURDELSKI  
 Marek MATYJEWSKI

## RELIABILITY AT THE CHECKPOINTS OF AN AIRCRAFT SUPPORTING STRUCTURE NIEZAWODNOŚĆ W PUNKTACH STRUKTURY NOŚNEJ STATKÓW POWIETRZNYCH\*

*For complex systems, such as the structure of an aircraft, the implementation of prognostic and health management techniques can effectively improve system performance. This paper presents some recent results of research on risk assessment for aircraft structures and intends to show the procedures of reliability calculation for a point of aircraft structure as an object under investigation. In this paper, the ways to determine failure rate and failure probability at the location of interest have been presented based on the example of the PZL-130 TC II ORLIK aircraft structure. The results can be applied to optimize the process of aircraft flight authorization, while ensuring safety during operations.*

**Keywords:** aircraft structure, reliability testing, crack propagation.

*W przypadku złożonych systemów, jakim jest struktura samolotu wdrożenie technik prognostycznych oraz zarządzania czasem zdatości do eksploatacji może skutecznie poprawić wydajność systemu. Celem publikacji jest przedstawienie metody oceny niezawodności konstrukcji lotniczych oraz odpowiedniej procedury obliczeń wraz z ostatnimi wynikami badań. W niniejszej pracy określono chwilową intensywność uszkodzeń oraz prawdopodobieństwo awarii w wybranych miejscach struktury samolotu PZL-130 TC II ORLIK. Uzyskane wyniki mogą być zastosowane do optymalizacji procesu dopuszczenia statków powietrznych do lotów, przy jednoczesnym zapewnieniu bezpieczeństwa ich eksploatacji.*

**Słowa kluczowe:** struktura nośna samolotu, badania niezawodnościowe, propagacja pęknięć.

### 1. Introduction

This contribution presents a reliability prediction as well as sustainability methods for selected areas of the airframe in terms of fatigue processes and the aging process. Supporting structure may be classified as an element with a high correlation between the airworthiness parameter values and adequate fatigue life of the aircraft [27].

One of the most important issues associated with aircraft maintenance is analysing durability of their structure components [10, 20]. The previous experience in operation confirms that exhaustion of aircraft service life cannot be unambiguously identified with its unserviceability for further, reliable flights. Not always does the service life exhaustion result in the loss of aircraft technical condition and in the reliability parameters exceedance. The inadequacies of the traditional (service life) approach to aircraft maintenance used were the reason for developing new methods for assessing the durability of the aircraft structure, which are presented in the new study [21, 22].

The presented mathematical model is implemented with the use of specialized software known as PProbability Of Fracture (PROF) [13] and is commonly used by United States Air Force [4, 6]. National Research Council Canada [12, 24] uses a similar mathematical approach for reliability analysis of aircraft structure in its ProDTA (PRObabilistic Damage Tolerance Anylisis) software.

The presented method and the research results make it possible to extend aircraft service life. Discussed procedures are not performed for aircraft owned by Polish Air Force, particularly for PZL-130 TC II ORLIK aircrafts. The exceptions are the F-16, for which such analyses are performed by Lockheed Martin.

### 2. The reliability prediction method of support structure points

Failure rate function [5, 9] is defined as the limit, if it exists, of the ratio of the conditional probability that the instant of time,  $T$ , of a failure of an item falls within a given time interval  $t + \Delta t$  and the length of this interval,  $\Delta t$ , when  $\Delta t$  leads to zero, given that the item is in an up state at the beginning of the time interval, which can be described as:

$$\lambda(t) = \lim_{\Delta t \rightarrow 0^+} \frac{P\{t < T \leq t + \Delta t | T > t\}}{\Delta t} \quad (1)$$

where  $T$  is a continuous positive random variable of device operation time.

If  $T$  has a density  $f(t)$  and the distribution  $F(t)$  equation (1) will take the form [1÷3]:

$$\lambda(t) = \frac{f(t)}{1 - F(t)} \quad (2)$$

where  $F(t) = \int_0^t f(u) du = P\{T \leq t\} = 1 - P\{T > t\}$ .

Given the failure rate  $\lambda(t)$  the life distribution can be calculated by the equation:

(\*) Tekst artykułu w polskiej wersji językowej dostępny w elektronicznym wydaniu kwartalnika na stronie [www.ein.org.pl](http://www.ein.org.pl)

$$F(t) = 1 - e^{-\int_0^t \lambda(x) dx} \quad (3)$$

In the aircraft reliability analysis to determine the probability of failure two independent events are taken into consideration. The failure can be recognized as a state in which:

- crack length exceeds a pre-defined size  $a_{cr}$
- stress cycle at a crack size smaller than  $a_{cr}$  that produces a stress intensity factor  $K$  which exceeds the fracture toughness  $K_c$  is encountered.

Failure rate at the critical airframe location is calculated using the equation:

$$\lambda(t) = \lambda_1(t) + \lambda_2(t) \quad (4)$$

where:  $\lambda_1(t)$  – failure rate resulting from exceeding the allowable crack length  $a_{cr}$   
 $\lambda_2(t)$  – failure rate resulting from exceeding the allowable stress in flight.

Based on the knowledge of the failure rate  $\lambda(t)$  failure function can be calculated using the equation (3) for a single location.

Function  $g$  which defines the relation between stress intensity factor, stress, and crack size can be expressed as:

$$K / \sigma = \sqrt{\pi a} \beta(a) = g(a) \quad (5)$$

where:  $\sigma$  – stress,  
 $\beta(a)$  – geometry correction factor specified for a cracks length  $a$ .

For the material under consideration and a specific location in the aircraft supporting structure, the critical crack size  $a_{cr}$  is a value corresponding to a mean value of the fracture toughness  $\overline{K_c}$  and the mode parameter of the stresses occurring in flight for the place under consideration, which can be mathematically represented as:

$$a_{cr} = g^{-1} \left( \frac{\overline{K_c}}{\overline{\sigma}} \right) \quad (6)$$

where  $g^{-1}$  is the inversion of function (5).

The probability of component failure during a time period  $(0, t)$  caused by exceeding the allowable crack length can be described as:

$$F_1(t) = 1 - F_A(a^*(t_{cr} - t)) \quad (7)$$

where:  $F_A$  – the distribution function of crack length at the start of the interval,  
 $a^*(t)$  – the crack growth function corresponding to the time of failure  $t_f = t_{cr} - t$ ,  
 $t_{cr}$  – the time, when crack size will reach the predefined size  $a_{cr}$

Failure rate associated with cracks growing to  $a_{cr}$  is then given by (2):

$$\lambda_1(t) = \frac{f_1(t)}{1 - F_1(t)} \quad (8)$$

The probability that a peak load will cause a failure during a flight at time  $t$  for cracks that are less than  $a_{cr}$  can be calculated as:

$$POF(t) = \int_0^{\infty} \int_0^{a_{cr}} \hat{H}(\sigma_{cr}(a, k_c)) f_A(a) da \cdot f_{K_c}(k_c) dk_c \quad (9)$$

where:  $\hat{H} = 1 - H = P\{\sigma > \sigma_{cr} = K_c / \beta(a) \sqrt{\pi a}\}$  is the exceedance probability for the peak load per flight,

$f_A(a)$  is the density of the flaw size distribution at time interval  $t$ ,

$f_{K_c}(k_c)$  is the density for fracture toughness,

$POF(t)$  is the probability that a peak load will cause a failure during a flight at time  $t$ .

Failure rate due to a large stress can then be approximated by:

$$\lambda_2(t) = \frac{POF(t)}{\bar{t}} \quad (10)$$

where  $\bar{t}$  is the average flight length.

### 3. Reliability analysis - input data

Reliability analysis has been performed for a possible crack in the area of a wing in the flange of the main spar, between ribs No. 5 and 6 [11, 18]. The defect was classified as HTC (Hole Through Thickness Crack) [6] (shown in Fig. 1). The finite element method (FEM) model study area is shown in Fig. 1.

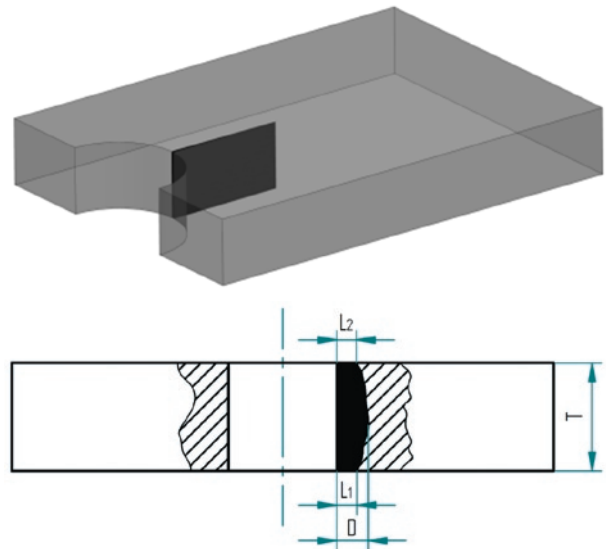

Fig. 1. HTC (Hole Through Thickness Crack) type damage on the graphic scheme

The parameter values which determine the normal distribution of  $K_{Ic}$  parameter which defines the fracture toughness for compact samples made of alloy 2024-T351 RCT type notched across the grain (L-T reference directions) are as follows:

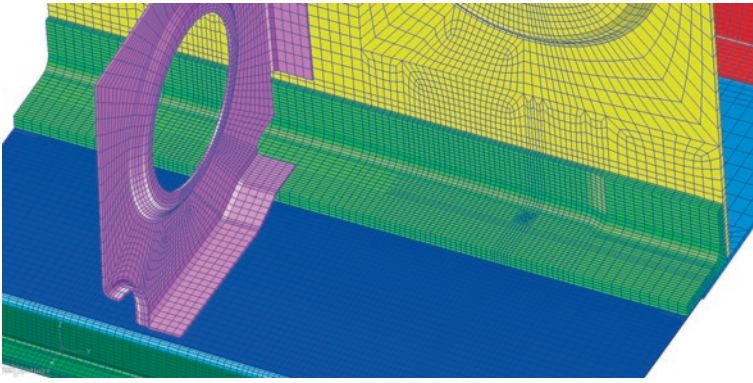

Fig. 2. FE model of the probable crack location [15]

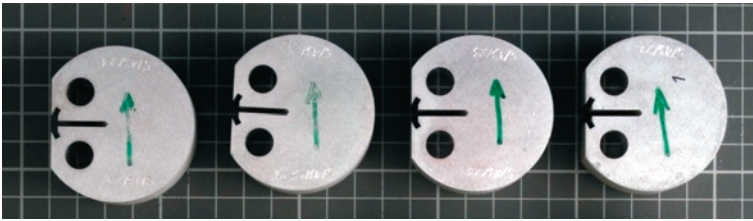

Fig. 3. RCT samples before testing [16]

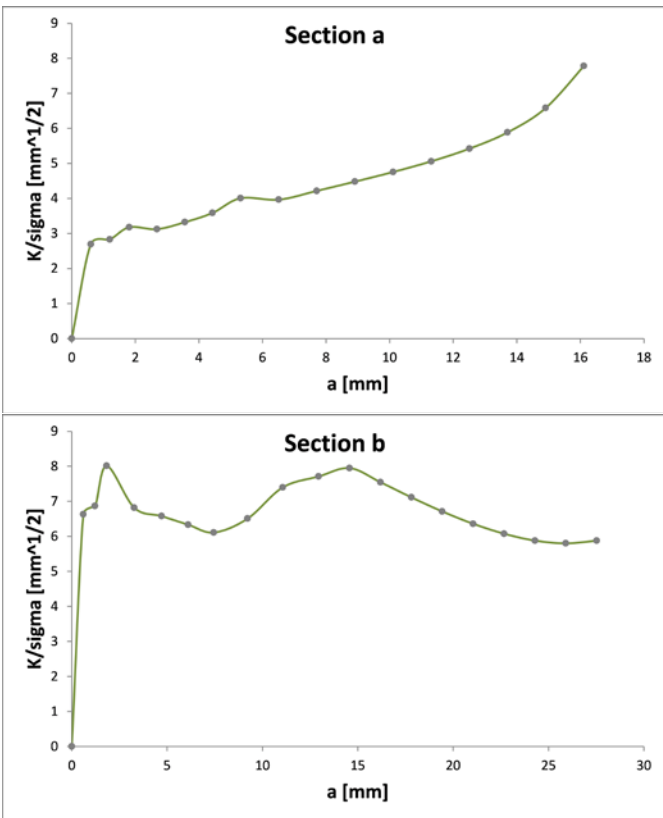

Fig. 4.  $K/\sigma$  versus  $a$  curve

- mean value –  $36.75 \text{ MPa}\sqrt{\text{m}}$ ,
- standard deviation –  $0.247 \text{ MPa}\sqrt{\text{m}}$  [16].

The static tensile tests were conducted in the Air Force Institute of Technology (AFIT) Laboratory for Materials Strength Testing [7, 16] with the use of material testing system MTS 810.23. The scope of the research included: a static tensile testing, the study of fatigue crack growth rate, material's resistance to fracture, low-cycle and high-

cycle fatigue testing (HCF & LCF). The scope of the research allowed to complete and verify material information used in the Orlik airframe in the extent regarded by the service life assessment program (SEWST).

FEM analysis was performed with the use of MSC Software [15]. Based on the FEM analysis results the relation between stress intensity factor, stress ( $K/\sigma$ ), and crack size  $a$  has been established.

The crack has been divided into two sections due to the fact that calculation of the crack propagation in the AFGROW software can only be performed for a geometry that contains no holes. Figure 2 shows crack propagation sections and directions.

Based on flight data records covering the period from the beginning of the service of Orlik aircraft in the Polish Air Force, the average length of the flight has been determined to be 43 minutes.

Based on the AFGROW software analysis results the obtained shape of the crack propagation curve  $a(t)$  is shown in black on Fig. 5. Green colour indicates an adequate fit to the equation (11). Red curves indicate extrapolation with the use of the exponential function:

$$a(t) = a_0 e^{bt} \quad (11)$$

In the calculation a simple *through crack* propagating from one side of the model was used. The relation between  $\beta(a)$  and crack size as well as the load spectrum based on strain gauge measurements were used. Material properties actual for 2024-T351 aluminum alloy such as Young's modulus ( $E$ ) and  $K_{IC}$  were established based on tests carried out in the laboratory [16]. Model data used in calculations are presented in the Table 1.

Table 1. Data used in crack propagation calculations [15]

Parameter	Section a	Section b
Length	0,01731 [m]	0,02915 [m]
Thickness	0,005 [m]	0,0025 [m]
Initial crack length	0,0006 [m]	0,00061 [m]
$K_{IC}$	36,75 [MPa $\sqrt{\text{m}}$ ]	36,75 [MPa $\sqrt{\text{m}}$ ]
$E$	72 000 [MPa]	72 000 [MPa]
Stress Multiplication Factor	0,072 [-]	0,072 [-]

The distribution of maximum stress peak in a flight is modelled in terms of a Gumbel distribution of extreme values and is based on flight research results:

$$H(\sigma) = \exp \left[ -\exp \left( -\frac{\sigma - B}{A} \right) \right] \quad (12)$$

- where:
- $\sigma$  – stress,
  - $A$  – Gumbel distribution parameter determining the slope of the cumulative distribution,
  - $B$  – Gumbel distribution parameter determining the 37th percentile of maximum stress on flights.

In order to obtain the  $A$  and  $B$  parameters of Gumbel distribution, correlation between maximum values of vertical load factor  $n_z$  and stress measured by strain gauge was verified. Data from 285 research flights with measuring-recording equipment KAM 500 were analysed. The next step of the calculation was to obtain a transfer func-

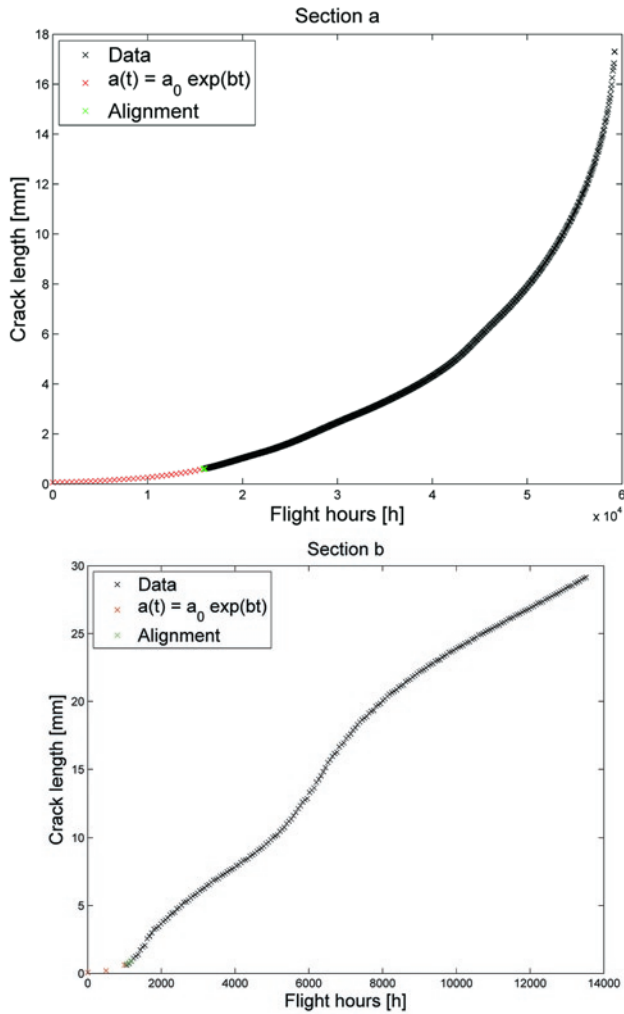

Fig. 5. Crack propagation curve

tion between vertical load factor  $n_z$  and stress. The algorithm of linear approximation that applies the method of least squares or non-linear Levenberg-Marquardt regression algorithm were used for calculation. Stress resulting from the global FE model calculations for  $n_z=1$  in the region of interest was extracted. Coefficients of the transfer function and maximum overload of vertical load factor  $n_z$  were obtained from on-board flight recorders mounted on PZL-Orlik TC-I and TC-II aircrafts from the beginning of operation in 2010 were used for calculation. At that time more than 40 000 flights were performed. Stress values have been approximated to the Gumbel distribution with coefficients:

$$A = 8.6 \text{ [MPa]},$$

$$B = 71.9 \text{ [MPa]},$$

using a fitting for flight, in which vertical load factor  $n_z > 4.6$ .

The initial crack size distribution was adopted pursuant to the article [7] (fig. 6).

Data from literature have been approximated using a Weibull distribution:

$$F_A(a) = 1 - e^{-(a/\lambda)^k} \quad (13)$$

where:  $\lambda$  – scale parameter,  
 $k$  – shape parameter.

The initial crack size distribution shape is close to the Weibull distribution function, which was justified by Yang and Manning [19, 26].

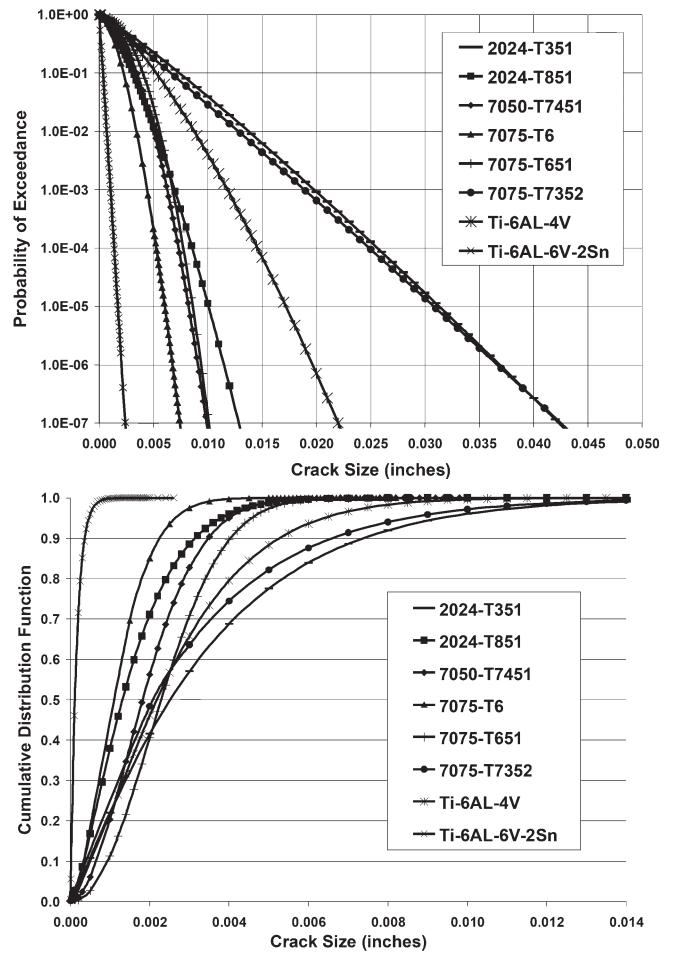

Fig. 6. Inverse cumulative distribution and cumulative distribution function for equivalent initial flaw sizes (EIFS) [7]

Following parameters were assumed for calculations:  $\lambda = 0.0891$  mm,  $k = 1.1204$ .

#### 4. Reliability analysis – result

For the crack section b, it is assumed that the beginning of crack propagation will be a time instant in which a section is damaged. For the military aircraft it is recommended to determine the event as unlikely (improbable). For the airframe it can be assumed that defect occurrence may not be experienced in the life of an item, if the failure rate is lower than  $10^{-6}$  during aircraft service life. Events unlikely, but possible to occur in the life of a component during service life of the aircraft have failure (probability of occurrence) less than  $10^{-3}$  but greater than or equal to  $10^{-6}$  (Table 2). Another important criterion for events qualification is the failure probability. If the value of  $F(t)$  exceeds  $10^{-3}$  admission to the further exploitation without schedule necessary inspections should be taken under consideration [23, 25]. Appropriate probability levels have been specified in the figure 7 of

Table 2. Probability levels [14]

Description	Level	Individual Aircraft	Fleet
Remote	D	Unlikely, but possible to occur in the life of an item during service life of the aircraft. Probability of occurrence less than $10^{-3}$ but greater than or equal to $10^{-6}$	Unlikely but can reasonably be expected to occur
Improbable	E	So unlikely, it can be assumed that the occurrence will not be experienced in the life of an item. Probability of occurrence less than $10^{-6}$	Unlikely to occur, but possible

failure rate. The figures 7 i 8 present charts of failure rate and failure probability of the area in aircraft PZL-130 TC II Orlik supporting structure.

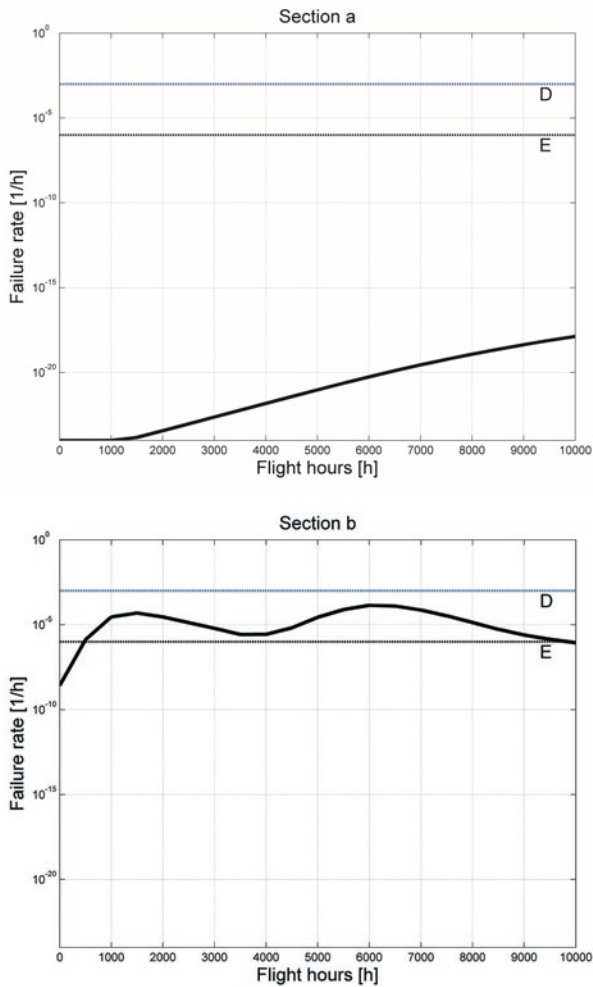

Fig. 7. Failure rate

## 5. Discussion of the results

The obtained simulation results indicate that a crack occurrence in the flange of main spar, between ribs No. 5 and 6 for 10 000 hours of service life can be described as improbable, since the probability of fracture, provided that the damage did not occur previously is less than  $10^{-6}$  during the aircraft service life period. The shape of the obtained curve shown in Fig. 7a is due to a moderate increase of the crack propagation curve in the initial periods of aircraft service life and a relatively low stress value at the considered checkpoint with respect to the  $K/\sigma$  versus  $a$  curve. On the assumption that the section located above the hole will start to propagate at a time when the previous section, located under the hole fails, the probability of failure in the next flight hour significantly increases. The most important factor influencing the failure rate of section b is the crack propagation rate. This damage can be described as unlikely (remote), since the probability of occurrence is less than  $10^{-3}$  but greater than or equal to  $10^{-6}$ .

For section b graphical comparison of relation between stress intensity factor, stress ( $K/\sigma$ ), and crack size  $a$  (Fig. 4) together with a failure probability (Fig. 8b) demonstrated a strong influence of geometry correction factor ( $\beta(a)$ ) on the reliability analysis. The fact that ( $K/\sigma$ ) curve for crack length of  $\sim 5$  mm (Fig. 4b) is not monotonic suggests a failure rate decrease in about 3 000 flight hours. Decrease

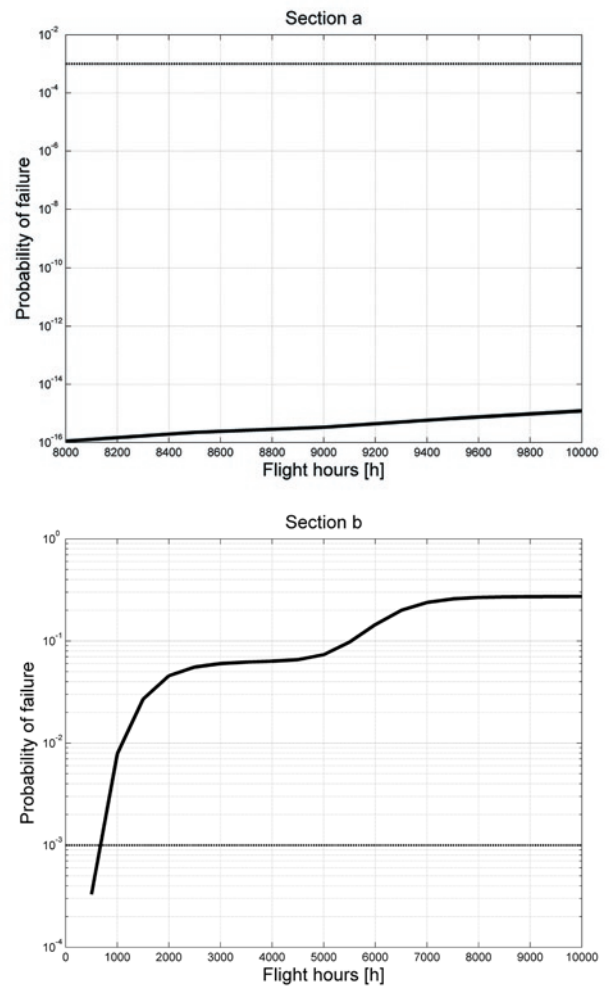

Fig. 8. Failure probability

in  $\lambda(t)$  function contributes to the slower failure probability increment within the period of 2 000 ÷ 5 000 flight hours.

## 6. Conclusions

The presented analyses have confirmed that it is possible and also advisable to determine the reliability at the points of the selected airframe locations. Approach of this kind while monitoring failures allows to make optimal decisions on flight approval, while ensuring the safety of an aircraft during operation. In addition, it was possible to specify the most important input parameters that have the greatest impact on the final assessment of the reliability at the checkpoints of airframe critical locations.

Performed research suggests that in the case of supporting structure components, essential for reliability are the parameters that define the crack propagation rate and structural determinants expressed by the dimensionless geometry correction factor (independent of the applied load) which specifies the state of stress in the crack tip and takes into account the shape of the tested element.

In the future an in-depth numerical methods study for reliability assessment is planned and implementation of the presented methodology on in-house software. Such an approach will enable time-saving and will provide accuracy of results through the use of effective optimization algorithms together with implementation in low-level languages.

## References

1. Babiarz B. An introduction to the assessment of reliability of the heat supply systems. *International Journal of Pressure Vessels and Piping* 2006; 4(83): 230-235, <http://dx.doi.org/10.1016/j.ijpvp.2006.02.002>.
2. Babiarz B. Chudy-Laskowska K. Forecasting of failures in district heating systems. *Engineering Failure Analysis* 2015; In Press, Corrected Proof, <http://dx.doi.org/10.1016/j.engfailanal.2014.12.017>.
3. Babiarz B. Risk assessment in heat supply system. *Safety and reliability: Methodology and Applications* 2014; 513-520.
4. Babish C. Application of risk & reliability analysis for fatigue cracking in F-16 aircraft structure. Technical report, 2010 F-16 ASIP.
5. Bedford T. Cooke R. *Probabilistic Risk Analysis Foundations and Methods*. Cambridge: Cambridge University Press, 2001, <http://dx.doi.org/10.1017/CBO9780511813597>.
6. Dixon B. Molent L. Ex-Service F/A-18 Centre Barrel Fatigue Flaw Identification Test Plan. Melbourne: DSTO Platforms Sciences Laboratory, 2003.
7. Gallagher J. Babish C. Malas J. Damage Tolerant Risk Analysis Techniques for Evaluating the Structural Integrity of Aircraft Structures. 11th International Conference on Fracture 2005; 1: 71-76.
8. Jankowski K. Reymer P. Simulating crack propagation of the selected PZL-130 ORLIK TC-II aircraft structural component. *Fatigue of Aircraft Structures* 2015, In Press.
9. Koucky M. Valis D. Reliability of sequential systems with a restricted number of renewals. *Proceedings and Monographs in Engineering, Water and Earth Sciences* 2007; 1845-1849.
10. Leski A. An Algorithm of Selecting a Representative Load Sequence for a Trainer. 2nd International Conference on Engineering Optimization 2010; CD: 1-8.
11. Leski A. Reymer P. Kurdelski M. Development of Load Spectrum for Full Scale Fatigue Test of a Trainer Aircraft. *ICAF 2011 Structural Integrity: Influence of Efficiency and Green Imperatives* 2011: 573-584.
12. Liao M. Bombardier Y. Renaud G. Bellinger N. Cheung T. Development of advanced risk assessment methodologies for aircraft structures containing MSD/MED. *ICAF 2009 Bridging the Gap between Theory and Operational Practice* 2009: 811-837.
13. Miedlar P. Berens A. Hovey P. Boehnlein T. Loomis J. PROF v3 PRObability Of Fracture Aging Aircraft Risk Analysis Update. Dayton: University of Dayton Research Institute, 2005.
14. MIL-STD-882E, Department of Defense, Standard Practice For System Safety 2012.
15. Podskarbi S. Leski A. Reymer P. Jankowski K. Kurdelski M. Stefaniuk M. Obliczenia stanu naprężenia oraz obliczenia szybkości wzrostu pęknięć dla CP z wykorzystaniem rzeczywistych widm obciążeń eksploatacyjnych. Sprawozdanie nr SP-58/31/2014. Warsaw: Air Force Institute of Technology, 2014.
16. Raport z badań nr 5/13. Raport z badania odporności materiału na pękanie. Warsaw: Air Force Institute of Technology, 2013.
17. Reymer P. Jankowski K. Kłysz S. Lisiecki J. Leski A. Crack propagation of the selected PZL-130 Orlik TC-II aircraft structural component based on laboratory test results. *Proceedings of the Fourth Asian Conference on Mechanics of Functional Materials and Structures* 2014, 181-184.
18. Reymer P. Leski A. Flight Loads Acquisition for PZL-130 ORLIK TCII Full Scale Fatigue Test. *Fatigue of Aircraft Structures* 2011; 3: 78-85, <http://dx.doi.org/10.2478/v10164-010-0041-7>.
19. Rudd J. Yang J. Manning S. Garver W. Durability Design Requirements and Analysis for Metallic Airframes. *Design of Fatigue and Fracture Resistant Structures*, ASTM STP 761, American Society for Testing and Materials 1982; 133-151.
20. Tomaszek H. Jaształ M. Zieja M. A simplified method to assess fatigue life of selected structural components of an aircraft for a variable load spectrum. *Eksploatacja i Niezawodność - Maintenance and Reliability* 2011; 4: 29-34.
21. Tomaszek H. Jaształ M. Zieja M. Application of the Paris formula with  $m=2$  and the variable load spectrum to a simplified method for evaluation of reliability and fatigue life demonstrated by aircraft components. *Eksploatacja i Niezawodność - Maintenance and Reliability* 2013; 4: 297-303.
22. Valis D. Koucky M. Zak L. On approaches for non-direct determination of system deterioration. *Eksploatacja i Niezawodność - Maintenance and Reliability* 2012; 1: 33-41.
23. Valis D. Vintr Z. Dependability of mechatronics systems in military vehicle design. *Proceedings and Monographs in Engineering, Water and Earth Sciences* 2006; 1703-1707.
24. Valis D. Vintr Z. Koucky, M. Contribution to highly reliable items' reliability assessment. *Reliability, Risk and Safety: Theory and Applications* 2010; 1-3: 1321-1326.
25. White P. Molent L. Barter S. Interpreting fatigue test results using a probabilistic fracture approach. *International Journal of Fatigue* 2005; 27: 752-767, <http://dx.doi.org/10.1016/j.ijfatigue.2005.01.006>.
26. Zieja M. Wazny M. A model for service life control of selected device systems. *Polish Maritime Research* 2014; 2(21): 45-49.
27. Żurek J. Models of team actions within the national rescue system. *Journal of Konbin* 2011; 4(20): 185-200.

**Marta WOCH****Marcin KURDELSKI**

Airworthiness Division

Air Force Institute of Technology

ul. Księcia Bolesława 6, 01-494 Warsaw, Poland

E-mail: marta.woch@itwl.pl, marcin.kurdelski@itwl.pl

**Marek MATYJEWSKI**

Division of Fundamentals of Machine Design

Warsaw University of Technology

ul. Nowowiejska 24, 00-665 Warsaw, Poland

E-mail: mmatyjew@meil.pw.edu.pl