

Simulating In-Situ Leaching Process Using COMSOL Multiphysics

Bakhyt K. Mukhanov, Zhanar Zh. Omirbekova, Azamat K. Usenov, and Waldemar Wójcik

Abstract—The paper deals with simulation of in-situ uranium leaching technological process, collecting data for forecasting and leaching process control. It provides numerical simulation of uranium in-situ leaching (ISL) using Comsol Multiphysics software package application.

Previous studies evaluated main hydrodynamic characteristics of wells and reservoirs, such as the coefficient of resistance and the saturation recovery; while this paper is concerned with determining the changes in process variables in the wells during operation.

Keywords—in-situ leaching, uranium, modeling, partial differential equations, Darcy's law, filtration, multiphysics, diffusion

I. INTRODUCTION

CURRENTLY the in-situ leaching (ISL) is a fundamental process for extraction of plenty of metals. At the same time there are a number of ISL technology modes, such as “saturated mode,” “pressure filtration” mode, or infiltration mode, which are to be determined according to measured process variables.[1,2]

In-situ leaching is a process in which involves dissolving the useful component by a chemical reagent in the ore body resting place followed by the export of the formed compounds from the reaction zone by the moving stream of solvent. Leaching is a diffusion process, which presents transition of system components from a solid phase to a liquid phase. The factor characterizing the intensity of such processes is the difference between the values of concentrations of the solvent and leachable component in the layer adjacent to the surface of the solid particle, and in the total volume of the liquid phase.

The leaching process occurs in permeable ore hosting rock where the solvent is filtered forcibly. Ore hosting rock is usually represented by sand admixed with clay and other minerals. Uranium minerals constitute hundredths and tenths of a percent; they have different shape and size, form films, sinters, crusts on grains or are embedded in aggregate structures of ores. [2]

The leaching process (ISL) comprises three main stages:

- Transportation of solvent to the surface of uranium minerals;
- Chemical reaction with the formation of soluble uranium salts;

Bakhyt K. Mukhanov, Zhanar Zh. Omirbekova, and Azamat K. Usenov are with Department of Automation and Control, K.I. Satpaev Kazakh National Technical University, Almaty, Kazakhstan (e-mails: bmukhanov@verbulak.com; {zhanomir; usenov.azamat}@gmail.com).

Waldemar Wójcik is with Institute of Electronics and Information Technology, Lublin University of technology, Lublin, Poland (e-mail: waldemar.wojcik@pollub.pl).

- Transportation of the dissolved reaction products into the solution.

During the ISL of uranium from ores the transportation of the solvent to the surface and dissolved products from the interreaction place is determined by the solution infiltration rate. Each of the above stages may in its turn consist of several steps. Thus, in the case of formation of solid reaction product on the surface of the dissolved uranium mineral the process is made up of the following steps:

- 1) diffusion transfer of the reagent to the solid phase surface through the layer of liquid adjacent to the surface;
- 2) diffusion transfer of the reagent through the layer of the solid reaction product;
- 3) chemical reaction on the surface of the leachable uranium mineral;
- 4) diffusion transfer of the dissolved substance from the reaction surface layer through the reaction product layer;
- 5) diffusion transfer of the dissolved reaction product through the liquid layer adjacent to the surface of the solid phase.

Development of the field by the in-situ leaching method is possible under the following basic conditions:

- 1) the component to be extracted is present in the ores in the form of minerals easily disintegrated by diluted water solutions of the leaching reagent;
- 2) the ore forming minerals that enter into the ore composition have low acid capacity in reaction with technological solutions;
- 3) the ores either have natural permeability, or become solution permeable after artificial fragmentation.

The aim of modeling is building an ISL model and the investigation of the studied modes of ISL.

The second step requires conducting numerical experiments on the model and determining the nature of interaction between the process status variables.[3]

COMSOL Multiphysics is an interactive environment for the modeling and calculation of most scientific and engineering problems based on partial differential equations (PDE) by the finite element method. This software package allows extending standard models that use one differential equation (application mode) in multiphysical models for calculation of interconnected physical phenomena. This is feasible due to integrated physical modes, where the PDE coefficients are given in the form of clear physical properties and conditions, such as thermal conductivity, heat capacity, heat transfer coefficient, volumetric capacity, etc. depending on the chosen physical part. The conversion of these parameters into mathematical equation coefficients is automatic. The interaction with the program can be done either in a standard way, through a graphical user interface (GUI), or by programming using COMSOL Script or MATLAB language

scripts. Mathematical modeling and the finite-element analysis in many applications allows reducing costly and lengthy “design - manufacture – test” development cycles of new technological units. They may also be useful in optimizing the structures and modes of operation of existing operating systems.

In order to solve a PDE COMSOL Multiphysics uses the finite element method (FEM). The application launches the finite element analysis along with the grid which takes into account the geometric configuration of bodies, and error control using a variety of numerical solvers. Since many physical laws are expressed in the form of PDE, it is possible to simulate a wide range of scientific and engineering phenomena of many areas of physics such as acoustics, chemical reactions, diffusion, electromagnetics, fluid dynamics, filtration, heat and mass transfer, optics, quantum mechanics, semiconductor devices, structural resistance, and many others.

Besides the aforesaid, the application with the help of coupling variables allows combining models in different geometries and interconnecting models of different dimensionalities.

For setting and solving a problem the following steps are recommended:

- 1) Selecting the model dimensions, defining a physical partition in Model Navigator (each partition corresponds to a certain differential equation) and defining a stationary or non-stationary analysis;
- 2) Determining the workspace and setting the geometry;
- 3) Specifying the source data, dependence of the variables on their coordinates and time;
- 4) Specifying the physical properties and the initial conditions;
- 5) Specifying the boundary conditions;
- 6) Setting parameters and constructing the grid;
- 7) Determining the parameters of the decision-making device and running the calculation;
- 8) Configuring the display mode;
- 9) Getting the results [4].

II. NUMERICAL MODELING GROUNDWATER FLUIDS FILTRATION PROCESS IN THE COMSOL MULTIPHYSICS ENVIRONMENT

COMSOL Multiphysics is used for numerical modeling of flow distribution for the analytical solutions, for applying different modes for the experiment modeling. The boundary and initial conditions are used as a starting point.

Filtration is understood as the fluid motion in a porous medium. The medium is considered porous if it contains a significant number of voids the sizes of which are small compared to the typical dimensions of the environment.

A quantitative characteristic of the porosity may be the ratio of pore volume to the total volume $m = V_{porosity}/V_{total}$. Therefore porosity is a nondimensional quantity.

The account of porosity level of the environment apparently leads to the fact that the continuity equation for the continuous flow of homogeneous fluid [5]

$$\frac{\partial \rho}{\partial t} + \text{div}(\rho \vec{W}) = 0 \tag{1}$$

will take the form

$$\frac{\partial(m\rho)}{\partial t} + \text{div}(\rho \vec{W}) = 0 \tag{2}$$

where \vec{W} is the filtration velocity vector.

As to the Euler motion equations, in the theory of filtration there are a number of assumptions that allow recouring to Darcy’s law:

$$\vec{W} = -\frac{k}{\mu} \text{grad} \bar{P} \tag{3}$$

$$\bar{P} = P + \rho g L \tag{4}$$

ρ – density; P – pressure; g – acceleration of gravity; H – distance from the considered point of the environment to a fixed reference surface; μ – dynamic viscosity; k – permeability, i.e. conductivity of the porous environment in relation to a given liquid, \bar{P} - total pressure, L - well depth.

III. PHYSICAL FORMULATION OF THE PROBLEM

Some wells are drilled in an ore body, i.e. in a geotechnological field. The leaching solution is fed into one

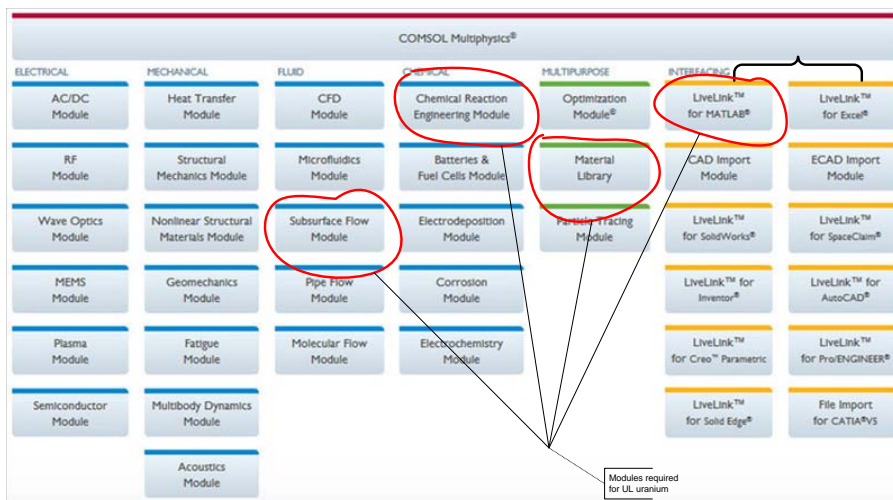

Fig. 1. Structure of COMSOL Multiphysics application module packages

of them (injected wells), and the productive uranium containing solution is extracted from the others (pumped wells) and is supplied for further processing.

While in-situ uranium leaching by the borehole systems it is necessary to maintain the balance of pumped and injected fluids in the cells and blocks, i.e. the total consumption of fluids in pumped wells and injected wells must be the same ($\sum W_{input} = \sum W_{output}$).

The process occurs in the geotechnical field with the length - x, and the width - y.

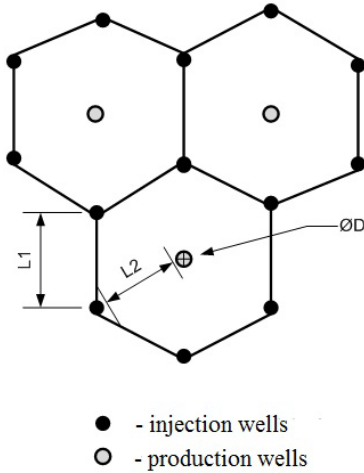

Fig. 2. Mineral extraction scheme

IV. MODELING

The main aims of the modeling are:

- assessment of parameters of underground fluids flow by comparing the numerical results with experimental measurement data;
- predicting the flow patterns.

Two modules were used in the COMSOL application: the Darcy's law (dl) was used to determine the hydraulic pressure head in time and space; and the Lagrange-Euler method of arbitrary constant (ale) - to calculate the change in the flow of underground fluids.[5,6]

The parameters were evaluated mainly on the basis of a 2D model. A 3D model provides a better understanding of more complex situations in which the heterogeneity and the surrounding groundwater flow can be taken into account. The 3D model was developed using the calibrated parameters of the 2D model.

V. THE RESULTS OF NUMERICAL SOLUTION

The results of numerical solution are given below. In this work we have selected two types of well locations. In the first type, the number of wells is equal to two; one of them is an injection well, which is located in one quarter of the distance, and a production well - in three quarters. In the second type the injection wells are located in one quarter and three quarters of the distance, and the production well - in the center. In both cases, the size of the area and the total debits of injection and production wells were considered to be equal. Figures 2-6 show the distribution of the hydrodynamic pressure field, the

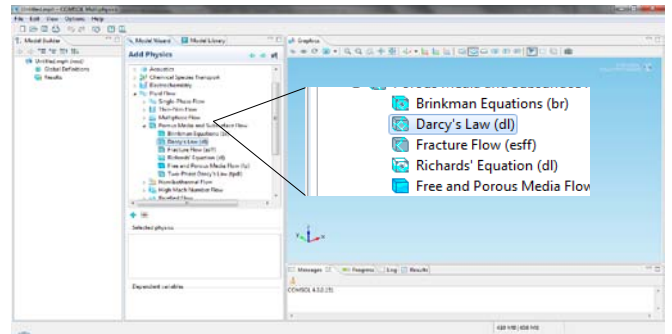

Fig. 3. Graphical user interface of modeling in COMSOL

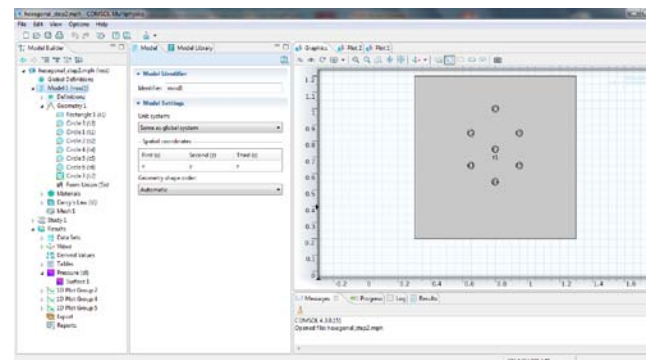

Fig. 4. Construction of the geometry of a simulated object

velocity field, the field of mineral concentration in the solution in the first case.

With the help of COMSOL Multiphysics there can be obtained the implementation of model (3) and (4) in a visual representation, this also allows estimating the filtration process in various operation modes.

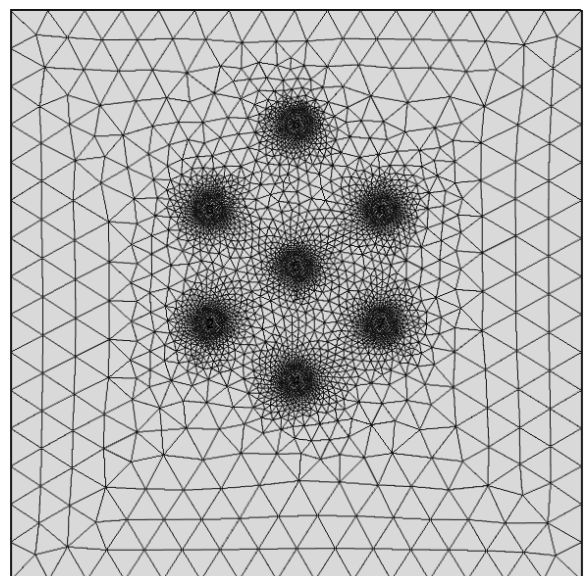

Fig. 5. Automatic partitioning into the grid (number of nodes 3165, the number of points 129312)

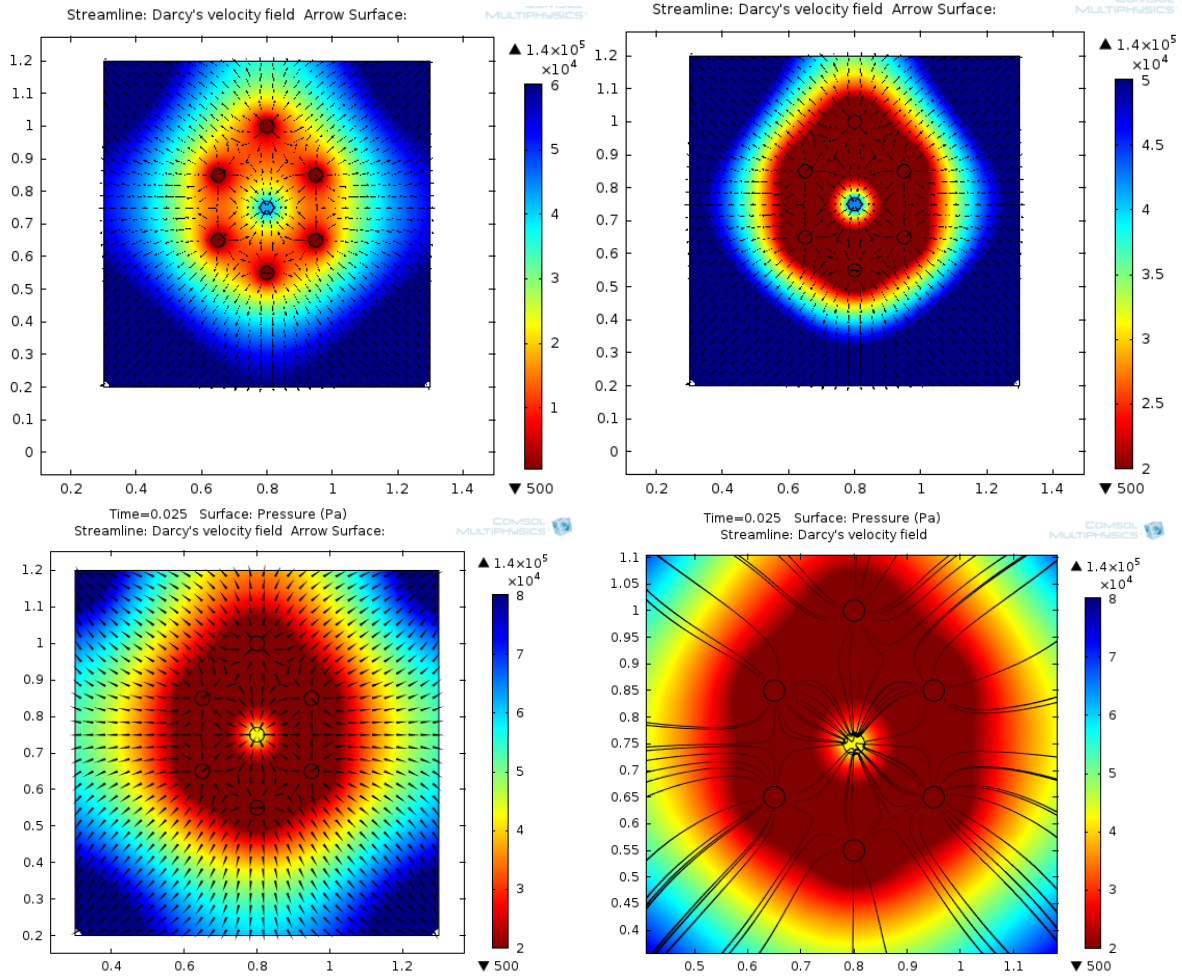

Fig. 6. Results of 2D modelling

VI. CONCLUSIONS

As a physical-chemical process the filtration leaching is determined by a set of parameters: filtration velocity; the nature and concentration of the solvent; the content of uranium in the ore; the physical properties of ore mass, which determine the state and properties of heterogeneous systems at the moment. The leaching velocity increases with the increase of solvent concentration, which also leads to an increase in the degree of extraction.

The reaction between the liquid and the solid substance develops from the particle surface to their center; and until the complete leaching there remains the unreacted core in the center, and a solid substance on the surface.

The ore material with its porous structure hinders the diffusion process offering it resistance. The less the diffusion resistance, the higher the leaching velocity and the degree of uranium extraction at a given duration of leaching.

The total resistance of the process consists of diffusion and chemical resistances. If the resistance of one of the steps is many times higher than the resistance of the remaining stages, the total flow of the process is limited by the slowest stage. In the presence or formation of a solid product under a dense shell on the surface of the dissolved uranium mineral the limiting stage is the diffusion through this layer. In this case the impact of leaching conditions on its velocity corresponds to the internal diffusion laws.

The interaction of the reagent with uranium minerals represents the first stage of leaching; at the second stage the dissolved substance moves along the layer together with the filter solvent.

The transportation of the substance as a whole is carried out by the liquid movement (convective diffusion).

The reaction of hydrogen addition to the anion of the solute compound underlies the mineral dissolution in acid.

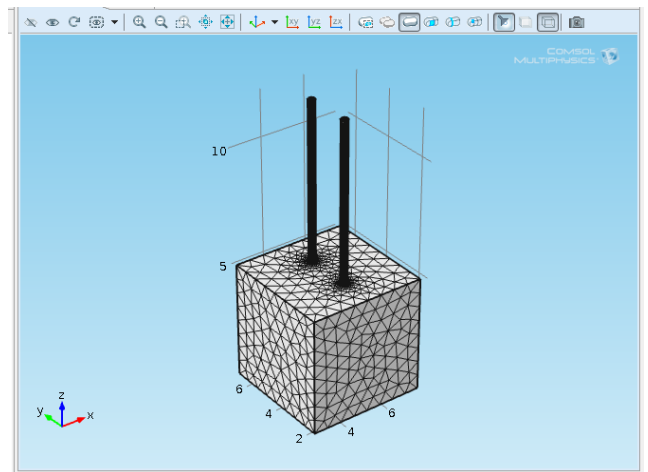

Fig. 7. 3D Mesh Partitioning model

Contour: Pressure (Pa) Streamline: Darcy's velocity field Arrow Volume: Darcy's velocity field

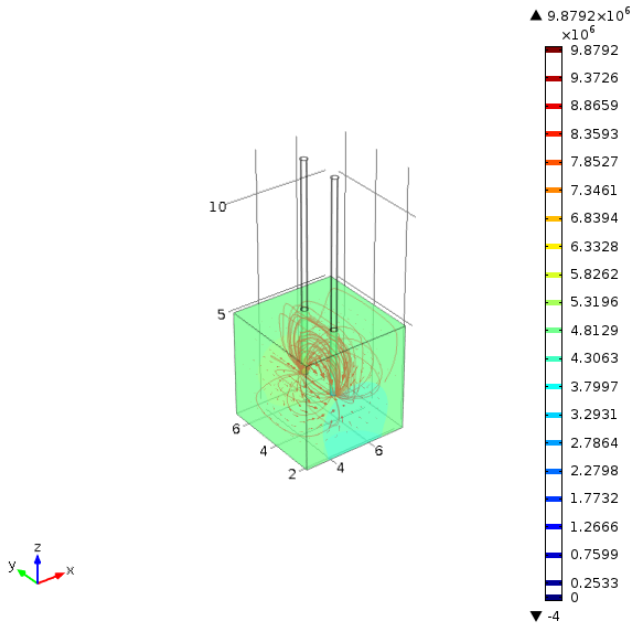

Fig. 8. Distribution of hydrodynamic pressure field

REFERENCES

- [1] J. C. DiCarlo, B. A. Hargreaves, K. S. Nayak, B. S. Hu, J. M. Pauly, and D. G. Nishimura, "Variable Density Excitation Pulses in One-Shot Fourier Velocity Encoding for Valve Flow Imaging", *Magnetic Resonance in Medicine*, vol. 54, pp. 645–655, 2005.
- [2] H. Lomax, T. H. Pulliam, D. W. Zingg, and T. A. Kowalewski, "Fundamentals of Computational Fluid Dynamics", *Applied Mechanics Reviews*, vol. 55, issue 4, p. B61, 2002.
- [3] Squires, Todd, Quake, and Stephen, "Microfluidics: Fluid physics at the nanoliter scale", *Reviews of Modern Physics*, pp. 977-1026
- [4] Knowledgebase <http://www.comsol.com/support/knowledgebase/1172/> accessed on 12.08.2012
- [5] W. B. White and E. L. White, "Ground water flux distribution between matrix, fractures, and conduits: constraints on modeling", *Speleogenesis and Evolution of Karst Aquifers*, vol. 3, issue 2, pp. 2-6, 2005.
- [6] A. M. Femino, F. S. Fay, K. Fogarty, and R. H. Singer, "Visualization of single RNA transcripts in situ", *Science*, vol. 280, issue 5363, pp. 585-590, 1998.