

MAREK PŁACHNO
SŁAWOMIR BARANOWSKI
IRENEUSZ OŚLIŹNIOK

Difficulties related to the renovation of the reinforcement of the V shaft at PGG Oddział KWK Ruda Ruch Bielszowice

The article presents an analysis of the possibility of carrying out repairs of shaft reinforcement without limiting its transport tasks, with operating parameters in accordance with the technical documentation of the shaft hoist, specified technical condition of the girders and guides, using the capital of knowledge and experience in maintaining the required level of safety for guiding the extraction vessels in conditions of the acceptable wear of guides and girders included in the mine shaft hoist documentation.

Key words: mining shafts, shaft reinforcement, reinforcement repairs performed without limiting the transport tasks of the shaft, safety of guiding the extraction vessels in the shaft

1. INTRODUCTION

The shaft is a structure that requires appropriate maintenance and conservation, hence the reinforcement work is long and requires appropriate maintenance. A reinforced mining shaft is a multi-element structure, most often made of steel, the main purpose of which is to provide safe space for the movement of the lifting vessels moving in the shaft during its transport tasks. This space is a limited area of possible horizontal displacements of the suction vessel in the shaft, ensuring that events such as contact of the vessel with the shaft casing, with its equipment, as well as contact with the other vessel while passing the vessels, can be considered by the users of the shafts as excluded.

In vertical mining shafts, a mechanical system for guiding extraction vessels from the so-called rigid guides. Such a system of guidance can be found in the

Ruch Bielszowice discussed in the article of shafts V of the combined mine Ruda. Being one of the most important shafts in PGG (Polska Grupa Górnicza) Oddział KWK Ruda Ruch Bielszowice, it performs the mining and downhill function, and is currently classified as one of the shafts with inspiratory functionality. In light of the shaft casing, it has a nominal diameter of 7.5 m and a total depth of 1111.62 m.

The system of guiding the exhaust vessels in shaft V consists of eight guide tracks. Each of them has a chain of guides formed by nine-meter box-section guides composed of two steel channel sections 200 attached to the main eastern and western girders, respectively. Each of the girders also has a box cross-section, however, it is composed of two steel channel sections 180. The structural diagram of the system for guiding the exhaust vessels in the shaft shield is shown in Figure 1.

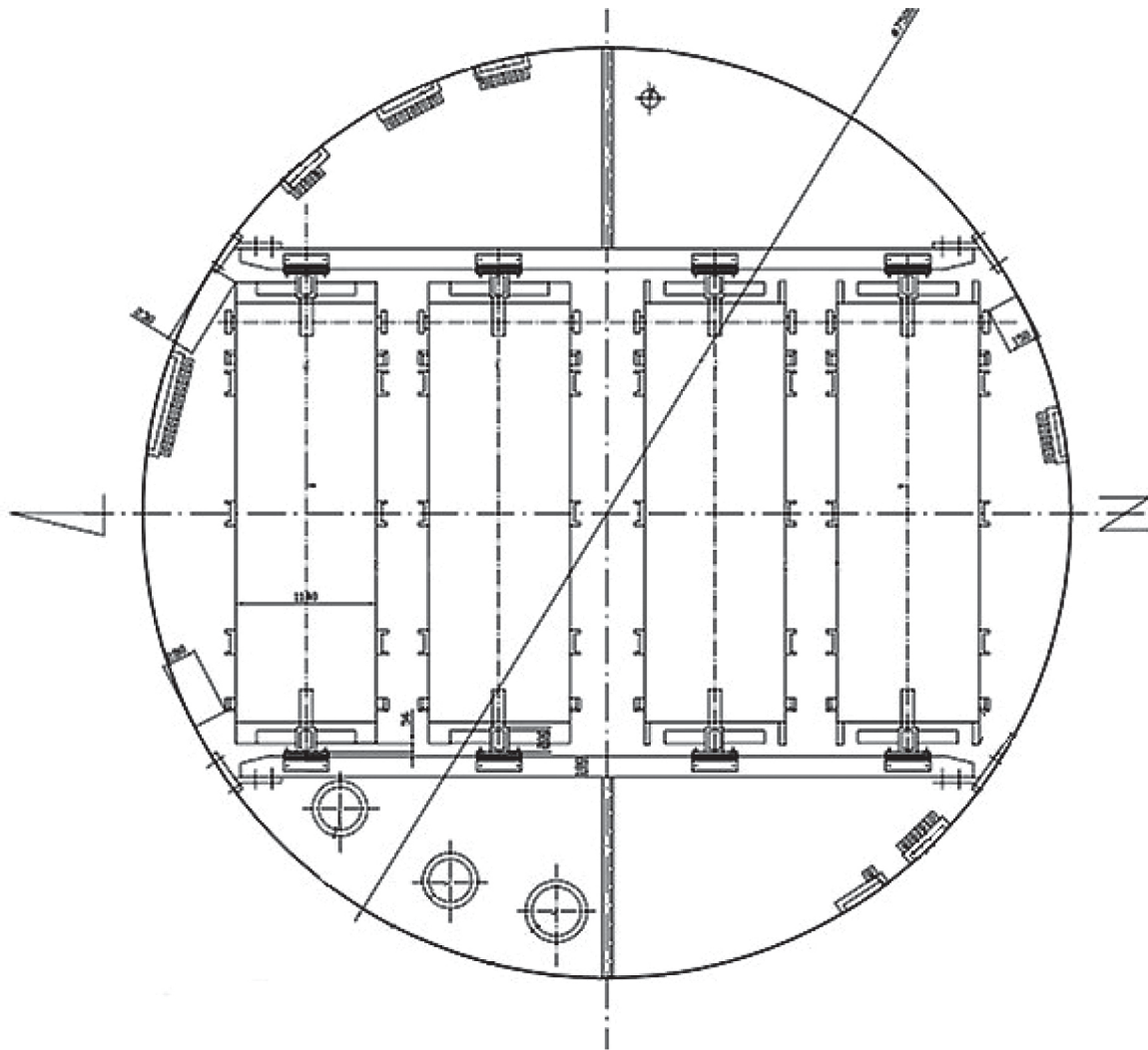

Fig. 1. Structural diagram of the reinforcement system in the V shaft shield at KWK Ruda Ruch Bielszowice

2. ACTIONS TAKEN TO SOLVE THE PROBLEM AND THE RESULTS OBTAINED

Based on the results of routine wall thickness measurements of the guides and girders in the V shaft [1, 2], a forecast of the progress of their wear in the subsequent years of shaft use was made, and then the results of this forecast were subjected to statistical analysis. On this basis, the premises of the problem of shaft reinforcement renovation were determined and presented below:

- During the use of the V shaft in the near future, we expect: developed progress in the wear of the guides and girders [3, 4], characterized by the fact that the number of replacements of these elements required in subsequent years due to exceeding the permissible wear and tear may be much greater than the number of replacements possible due to the mining tasks of the shaft.

- Rapid progress of the non-parametric form of wear of the guides is expected, manifested by cracks in the welds at their ends in the joints of the guide sections.
- Rapid progress is expected in the perforation of the upper walls of the main girders, occurring mainly at both ends adjacent to the anchored consoles, and often propagating towards the support of the guides.
- Rapid progress is also expected in the perforation of the upper walls of the struts, largely randomly located along their length.

Taking into account the renovation needs of the V shaft reinforcement and the fact that its mining tasks should not be limited, it was decided to carry out an examination of the substantive possibilities of increasing the permissible wear of the guides and girders by more than 50% of the initial thickness of their webs.

The steps of this discernment were carried out as follows:

1. Analysis of the straightness of the lead tracks in shaft V and determination of the conditions for its improvement.
2. Diagnosis of the causes of weld cracks in the chain section connection and determination of the impact of such damage on the safety of the chain's use.
3. Determination of the impact of perforation of the upper walls of main and strut girders on the safety of the guide tracks.

The merit of the first step of research was the assumption that the greatest deviations from straightness, determining the greatest forces of the suction vessel on the shaft reinforcement, are the sum of two components [4]. One of them has a structural origin, resulting from the geological deformation of the shaft casing and the dimensional tolerance of the reinforcement elements in the shaft. The second – as a result of corrosion of the connections between the guides and the girders – is caused by the clusters of gap disappearances on the assembly of the strings of the guides. The experience already obtained in this

field [4, 5] has shown that using the straightness measurement reports of the guides in the shaft, prepared routinely (see point 3.13.7.6. Annex No. 4 to the Regulation [6]) for each shaft with rigid guides, it is possible – by means of an appropriate statistical analysis – to isolate both of these components, and also to verify them by making an inventory in the shaft of the above-mentioned clusters of fissure disappearances.

On the basis of the measurement survey [7], for all guide tracks in the V shaft, diagrams were developed reflecting the distributions of differential frontal and lateral deviations from the straightness of the tracks leading the extraction vessels along successive main girders in the shaft. Figure 2 shows, as an example, graphs representing one of these distributions. Each of the discussed distributions was then subjected to the mentioned statistical analysis. It showed that for each of the guide tracks in shaft V, the proportion of the corrosive component in the extreme values of these deviations is not less than 50%. On this basis, it was decided to carry out an inventory of fissure disappearances in the assembly of individual sequences in shaft V, and then to take steps to remove the identified clusters of these disappearances.

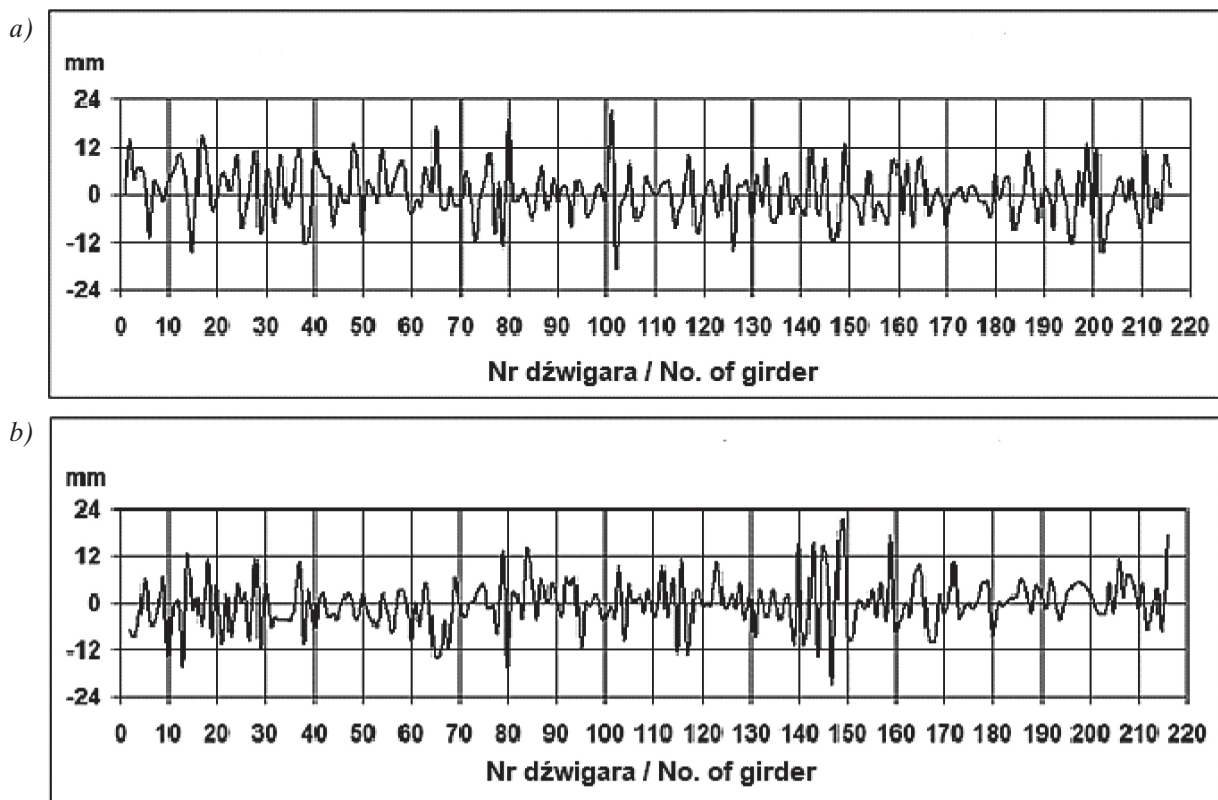

Fig. 2. One of the distributions – along the successive main girders – of differential frontal (a) and lateral (b) deviations from the straightness of the tracks leading to the hoisting vessels of the eastern southern ski-frame track in shaft V, developed on the basis of the measurement survey [7]

Approximately 3 months after the removal of the largest clusters of gap disappearances on the assembly of the chain of individual track guides, straightness measurements were made again and, based on the measurement frame [8], graphs were again developed reflecting the distribution of differential frontal and lateral deviations from straightness along successive main girders in the V shaft, illustrating effect of actions taken. These charts (Fig. 3) were drawn on the same scale as the previous ones (Fig. 2), which was meant to facilitate the perception of the obtained effect. This effect, in the case of the eastern southern snap-shot guide, is to reduce the greatest frontal deflections from 21 mm to 9 mm and the greatest lateral deflections from 20 mm to 7 mm. As a similar effect was obtained for the remaining lead tracks in the northern section of shaft V, it was not only found that the assumptions made were correct, but also the action taken and implemented was justified.

The second step in the scope of the research undertaken was, as already mentioned, the diagnosis of the causes of the weld cracks in the connection of the chain sections and the determination of the impact of such damage on the safety of the chain's use. For this

purpose – for the chain sections showing the damage in question – a calculation scheme of the stresses experienced by the weld as above was adopted, shown in Figure 4. The computational force (P_c) of the girders included in it, which, when the V shaft reinforcement was designed, was defined as:

$$P_c = \frac{1.3 \cdot Q}{12} \quad (1)$$

where Q – the weight of the draft vessel with a maximum payload of 40 kN.

Using the relationships given in [9], for the calculated stresses, the following formula was formulated:

$$\sigma_s = 0,75 \cdot \frac{2 \cdot p \cdot \frac{h}{b} + 3}{\left(p \cdot \frac{h}{b} + 3\right)} \cdot \frac{P_c \cdot b}{g_s^2 \cdot c} \quad (2)$$

where:

- p – dimensionless coefficient which for the section of a guide made of two 200 channels is equal to 2.48,
- c – distance of the guide's end edge from the axis of its holder, given in [9] as 290 mm.

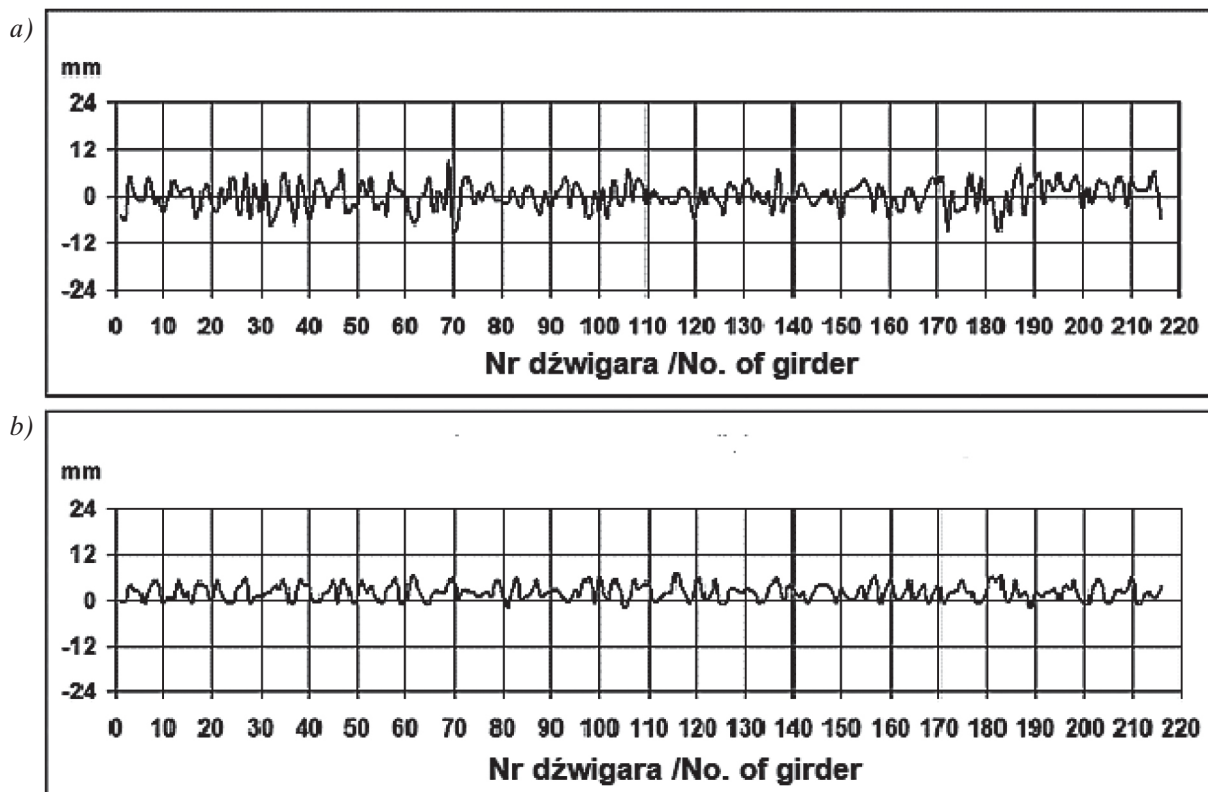

Fig. 3. One of the distributions developed on the basis of the measurement [6] – along the successive main girders – of differential frontal (a) and lateral (b) deviations from the straightness of the traction vessel tracks of the eastern southern ski-cage track in shaft V – after removing the largest clusters of gap disappearances on folding the chain of guides

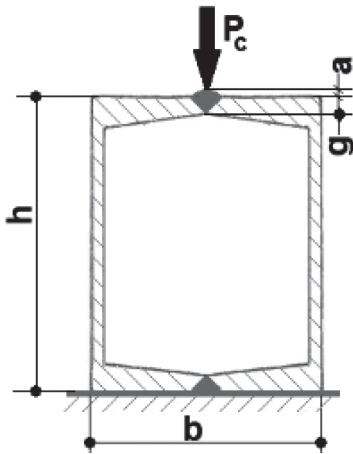

Fig. 4. Calculation diagram for stresses in the weld connecting the chain sections

a – joint convexity defined in the BN-78/1727 [1] standard as $a \leq 1.5 \text{ mm}$, b – the width of the front wall of the chain equal to 150 mm, g – joint thickness defined in [9] as 7 mm, h – side width guide walls equal to 200 mm, P_c – girders calculation force

Using formulas (1) and (2), it was calculated that when the actual force of the extraction vessel on the shaft reinforcement reaches the value of the force P_c , the stress σ_s may have a value of approx. 530 MPa, which means that it will be greater than the immediate strength R_m of the material guides of 380 MPa. Therefore, it was found that the direct cause of cracking of the weld connecting the chain sections is the convexity of this weld, although such convexity is accepted by the standard BN-78/1727 [1].

On this basis, the impact of the damage in question on the safe use of the chain is as follows:

- Each fracture of the weld has a tendency to propagate along the weld in both directions, and therefore in the conditions of shaft V it will endanger the safety of the chain when it reaches the length of 0.5 m. Then, the chain with such damage may experience a rapid loss of lateral stiffness, which –

- with a probability significantly greater than zero – may lead to the suction vessel falling out of its guide tracks. Any chain in the V shaft showing a weld fracture of a length equal to or greater than 0.5 m should therefore be replaced immediately.
- The guides in the V shaft which show a weld fracture less than 0.5 m in length may be operated if:
 - show wall wear lower than acceptable;
 - this consumption is controlled in accordance with the requirement of point 3.13.7.4.1 of Annex 4 to the Regulation [6];
 - the ends of the weld crack are protected against its propagation, e.g. by drilling an appropriate hole;
 - records of chains showing both existing and newly formed cracks in joints are verified at least every 6 months;
 - the records, in addition to the number of the girder closest to each fracture, contain information on the length of the recorded fracture and the absence or occurrence of its propagation beyond the securing holes.

The third and final step in the scope of the research undertaken was to determine the impact of the perforation of the upper walls of the main and strut girders on the safety of the guide tracks. For the main girders, this influence was determined by comparing the bending strength indices calculated – according to the diagram in Figure 5a – for the cross-section of the main girder without perforation of its walls with such indices calculated on the basis of the diagram shown in Figure 5b. The comparison was made using the graphs in Figure 6, which show the results of the calculations performed. On this basis, it was determined that the perforation of the upper wall of the main girders in the V shaft reduces their strength by approx. 16%, therefore the main girders in this shaft showing such damage can be safely used, as long as their wear outside the perforation area is not greater than 84% of the permissible wear of girders without perforation.

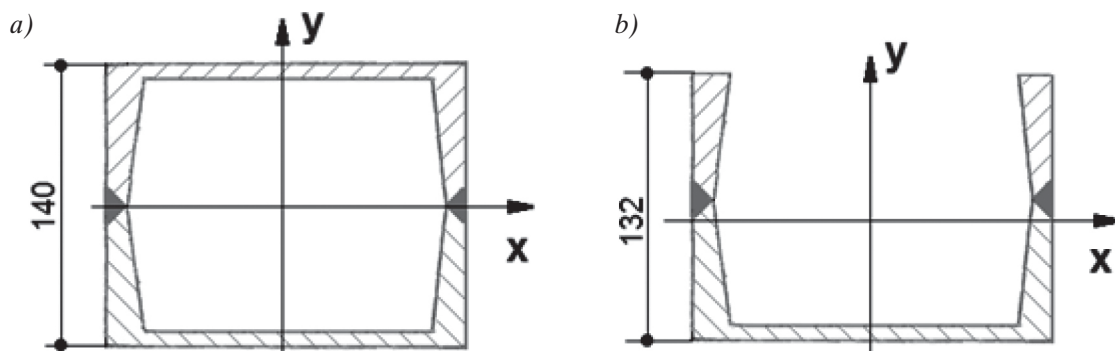

Fig. 5. Calculation diagrams of the cross-section of the main girder in the V shaft for the girder case: a) without perforation of its walls; b) with perforation of its upper wall

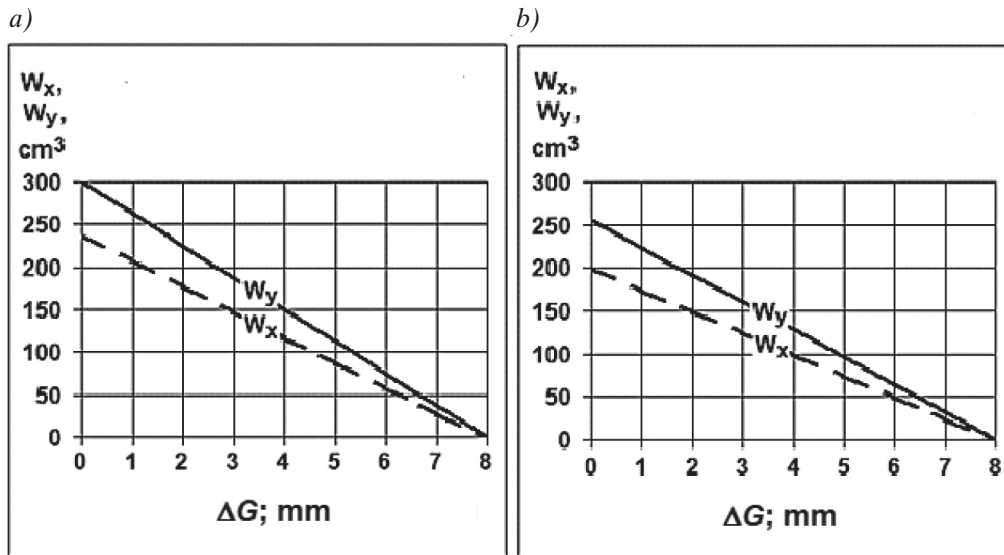

Fig. 6. Influence of the decrease in thickness (ΔG) of the walls of the main spar in shaft V on its bending strength indexes (W_x , W_y) in the absence of (a) or presence (b) of perforation of its upper wall

On the other hand, for the spreader beams, it was assumed that, before formulating the analysis scheme that would enable the determination of the impact of the perforation of their upper walls on the safety, calculations of the permissible compressive force of these beams were made. Their results (Fig. 7) showed that the perforation of the upper wall of the expansion beams in the V shaft significantly reduces their allowable compressive force that in strength calculations of the V shaft reinforcement, the perforated span beams cannot be considered as rigid supports of the main

beams. On this basis, it was assumed that the impact of the discussed damage to the spacers on the safety of the guide tracks in the V shaft can be determined when the safety coefficients of these tracks are compared, calculated in two ways, i.e. for the case of:

- expansion girders as rigid supports of the main girders, i.e. when the expansion girders do not show perforation;
- main girders without spreader girders, which happens when the spreader girders have had their upper walls perforated.

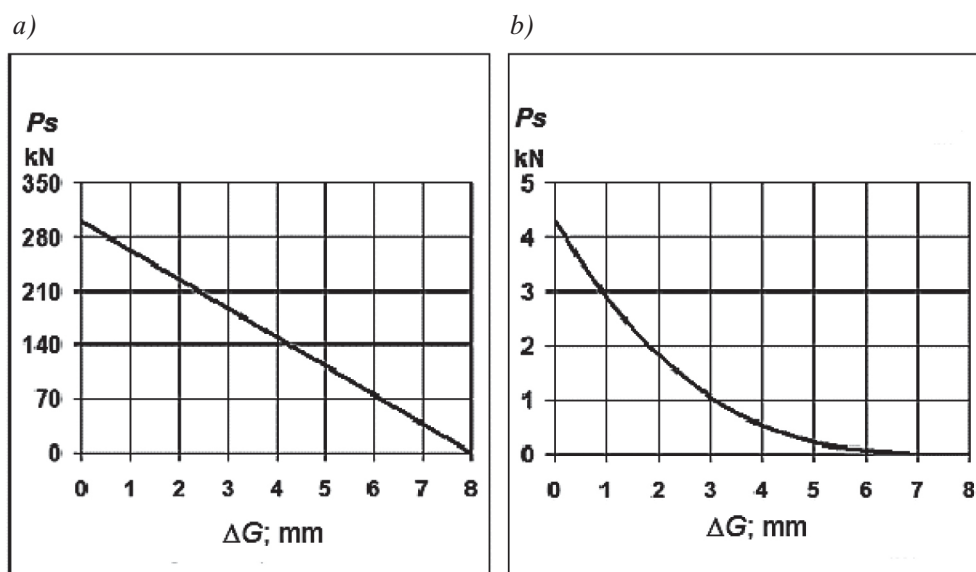

Fig. 7. Influence of the thickness loss (ΔG) of the walls of the expansion girder in the V shaft on the allowable compressive force (P_s) of this spar in the absence of (a) or the presence (b) of the perforation of its upper wall

The computations of the compared safety factors were made for each of the guide tracks in the V shaft with the following assumptions [4–6]:

- Each of the safety factors is the quotient of the immediate strength R_m of the material to the highest stress in the guide track elements, caused by the maximum frontal and lateral forces of the suction vessel on this track, in conditions of intense work of the sliding guide without the use of a rolling guide, as well as by vertical forces the resulting actions and the weight of the shaft reinforcement.
- The following factors of these forces were taken into account in the calculation of the maximum forces:
 - extreme frontal and lateral differential deviations from the straightness of each guide track in the V shaft, determined for the skip frame guide tracks in the northern section of the shaft based on the measurement frame [8], and for the skip run tracks in the southern section of the shaft on the basis of the measurement frame [7];
 - currently used operating parameters of individual hoisting vessels in shaft V, that is steady travel speed and permissible load capacity;
 - design parameters of the exhaust vessels in shaft V, determining the weight distribution of each of these vessels in its structure;
 - cross-sectional bending stiffnesses of guides, main beams and connection elements of guides with main beams and girders with the shaft casing;
 - bending length, which for main girders with strut girders damaged by the perforation of their upper walls are significantly greater than in the case of strut girders without such perforation.

One of the sets of calculation results of the compared safety coefficients is shown in Figure 8. Such

sets of results obtained for the tracks of the remaining vessels in this shaft turned out to be almost identical, therefore they were not published.

Based on the results of the discussed comparison, it was found that the perforation of the upper walls of the strut girders in the V shaft did not have a significant impact on the safety of the tracks of the exhaust vessels in the shaft. This is due to the fact that the loss of the expansion girder – due to the perforation in question – of its ability to perform the function of a sufficiently rigid support of the main girder causes a reduction in the structural rigidity of the main girder as a support for the guides attached to it. As a result – in the elastic range of the material – also the maximum frontal forces absorbed by the main girder from the suction vessels are proportionally reduced. Then the guidance track safety coefficient does not experience any significant reduction, nor does the deflection of this track increase significantly.

An equally important finding resulted from the evaluation of the values of both variables appearing in the graphs in Figure 8. With the wear of the walls of the guides and girders equal to 50% of the initial thickness of their webs, the smallest excess of the calculated value of the safety factor of the tracks leading the exhaust vessels in the V shaft, in relation to the required value of this coefficient as it amounts to approximately 67%. This statement indicated that with the current technical condition of the reinforcement of the V shaft, it is possible to maintain the required safety of the tracks of the extraction vessels during the renovation of this reinforcement with an increase of over 50% of the permissible wear of the guides and girders. On this basis, the user of the shaft in question decided to take action in this regard, in accordance with § 536 par. 1 lit. h of the Regulation [1] and with the recommendations given in the publication [2, 11].

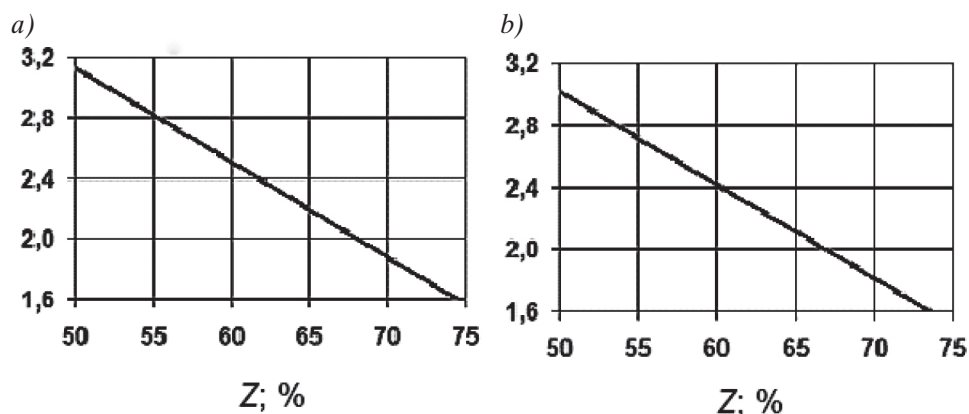

Fig. 8. One of the sets of results for the calculation of the safety coefficients of the southern ski-cage guides in the V shaft, corresponding to the stretchers without (a) and (b) with wall perforation, depending on the wear (Z) of the walls of the guides and main girders

3. SUMMARY

The problem with the renovation of the reinforcement of V shaft at PGG Oddział KWK Ruda Ruch Bielszowice is that with the traditional implementation of this renovation, it would be necessary – in the coming years – to significantly reduce the transport tasks of the shaft, because otherwise the number of necessary changes of guides and girders would be unattainable.

Bearing in mind the above, it was decided to carry out an examination of the substantive conditions for increasing the permissible wear of the guides and girders over 50% of the initial thickness of their webs. The creation of conditions in this regard would enable the implementation of plans for both the renovation of the reinforcement and the mining tasks of V shaft.

The conducted research showed that the conditions in question can be achieved by removing the main cause of the greatest forces of the extraction vessels on their tracks in the shaft, which are the largest deviations from the straightness of the guide strings caused by the disappearance of the slots in the assembly of these strings. In order to eliminate the indicated cause, appropriate works were undertaken in the shaft, the exemplary effect of which is shown in Figures 2 and 3 concerning the eastern ski-frame track in the northern part of the V shaft. This effect is to reduce the largest frontal deviations from 21 mm to 9 mm and the largest lateral deviations from 20 mm to 7 mm. As for the remaining guide tracks in the northern section of the V shaft, a similar effect was obtained, it was possible – by means of an appropriate analysis – to show that with the wear of the walls of the guides and girders equal to 50% of the initial thickness of their webs, the smallest excess of the calculated value of the safety factor of the reinforcement structure relative to the required value this ratio is approx. 67%.

Therefore, conditions were created for the renovation of the reinforcement in shaft V to be carried out without the need to limit the transport tasks of this shaft.

References

- [1] BN-78//1727-22: *Prowadniki szybowe. Prowadniki stalowe z ceowników.*
- [2] Jędruszek Ł., Potyka K.: *Sprawozdanie z wykonanych pomiarów stalowych elementów zbrojenia szybowego szybu V przedział "A" – przewodników stalowych*, Kompania Węglowa SA Oddział KWK "Bielszowice", Ruda Śląska 2014 [unpublished].
- [3] Kiercz M.: *Doświadczenia z pomiarów sił rzeczywistych oddziaływania naczynia górniczego wyciągu szybowego na zbrojenie szybu*, "WUG Bezpieczeństwo Pracy i Ochrona Środowiska w Górnictwie" 2009, 8: 21–25.
- [4] Płachno M.: *Nowe metody projektowania i eksploatacyjnej kontroli zbrojenia pionowych szybów górniczych*, Monografie. Akademia Górniczo-Hutnicza im. Stanisława Staszica. Wydział Inżynierii Mechanicznej i Robotyki, Problemy Inżynierii Mechanicznej i Robotyki, nr 31, Kraków 2005.
- [5] Płachno M.: *Doświadczenia poznawcze wynikające z badań sił rzeczywistych oddziaływania naczyń wyciągowych na zbrojenie szybów górniczych*, [in:] Klich A., Koział A. (red.), *Transport szybowy*, ITG KOMAG, Gliwice 2013: 19–32.
- [6] *Rozporządzenie Ministra Energii dnia 23 listopada 2016 r. w sprawie szczegółowych wymagań dotyczących prowadzenia ruchu podziemnych zakładów górniczych*, Dz.U. z 2017 r., nr 1118.
- [7] *Operat pomiarowy kontrolnych pomiarów geometrii obudowy i elementów zbrojenia, prostoliniowości torów prowadzenia naczyń oraz wartości luzów między przewodnikami szybowymi a przewodnikami ślizgowymi w szybie "V" KWK "Bielszowice"*, DARTECH, Mysłowice 2016 [unpublished].
- [8] *Opracowanie wyników geometrii zbrojenia i obudowy, prostoliniowości torów prowadzenia naczyń oraz wymiarów określonych w § 545 i 558 Rozporządzenia Ministra Energii z dnia 23 listopada 2016 r. (Dz.U. 2017 poz. 1118), szybu V przedział B*, PMG SILESIA Sp. z o.o., Katowice 2018 [unpublished].
- [9] Kubicki J., Polak J., Podziemski R., Cizek W.: *Prowadnik stalowy 200. Rysunek nr 322168a*, BPG, Katowice 1978 [unpublished].
- [10] Płachno M.: *Obliczanie poziomych sił dopuszczalnych zbrojenia szybowego z dźwigarami o dużej sztywności konstrukcyjnej*, [in:] Tytko A., Wójcik M. (red.), *Bezpieczeństwo pracy urządzeń transportowych w górnictwie*, Centrum Badań i Dozoru Górnictwa Podziemnego Sp. z o.o., Łędziny 2014: 126–137.
- [11] Szmelik P.: *Sprawozdanie z wykonanych pomiarów stalowych elementów zbrojenia szybowego szybu V*, PGG S.A. Oddział KWK Ruda Ruch Bielszowice, Ruda Śląska 2016 [unpublished].

MAREK PŁACHNO, prof.

Department of the Strength and Fatigue
of Materials and Structures

Faculty of Mechanical Engineering and Robotics

AGH University of Science and Technology

al. A. Mickiewicza 30, 30-059 Krakow, Poland

labniz.marek@gmail.com

SŁAWOMIR BARANOWSKI, Ph.D., Eng.

IRENEUSZ OŚLIŻNIOK, Eng.

PGG S.A. Oddział KWK Ruda

Ruch Bielszowice

ul. Halembaska 160, 41-711 Ruda Śląska, Poland

[s.baranowski, i.oslizniok]@pgg.pl