

# Assessment of Kernmantle Ropes in terms of Sheath Slippage: Method and Results

Krzysztof Baszczyński<sup>1\*</sup>

<sup>1</sup> Central Institute for Labour Protection–National Research Institute, Department of Personal Protective Equipment, Wierzbowa 48, 90-133 Łódź,

\* Corresponding author. E-mail: krbas@ciop.lodz.pl

## Abstract

Worksites at height require the protection of workers during both movement and task performance. The rope access technique involves the simultaneous use of working and backup textile rope systems. Currently, kernmantle ropes are most often used in conjunction with mechanisms that move along them and lock at the right moment. However, this mode of operation has a destructive effect on the rope. Ropes must therefore meet a number of specific requirements, one of the most important of which is sheath slippage. The paper presents a method for testing this parameter based on the requirements of EN standards, including the design and implementation of a test stand and a method for the verification of its operation. Test results for 11 types of ropes are presented and discussed. The paper also provides some guidelines for conducting tests.

## Keywords

kernmantle ropes, sheath slippage, falls from a height, guided type fall arresters.

## 1. Introduction

Many industrial worksites at height pose serious problems with regard to their accessibility to workers, safety, as well as worker comfort during task performance. Such worksites can be found, for example, in construction, civil and water engineering, offshore oil and gas industry extraction, and the wind energy sector. The use of equipment such as lifts, ladders, and scaffoldings may not be possible for technical reasons or may be uneconomical if the works concerned are of a limited scope. One way to solve this problem is to use the rope access technique [1-3], in which workers are suspended or supported while performing works at height. This method is derived from sports, recreational climbing, and cave exploration techniques [4, 5].

The rope access technique is based on the simultaneous use of two independent rope systems:

- a working rope system,
- a protective rope system.

The working system is supposed to allow the worker to move in the vertical direction and to assume a position at an appropriate height, suitable for performing the required tasks. Depending

on the equipment used, a change of position can be achieved by controlled descent or rope climbing. The objective of the protective system is to protect the worker in health- and life-threatening situations, e.g. in case of a failure of the working system. The protective system is designed to arrest falls within the shortest possible distance, in a way that minimises the likelihood of injury and allows the user to safely wait for help.

Textile ropes are an integral part of both systems. From the point of view of their structure, these are most often kernmantle ropes characterised by different elongation properties [6,7]. Both in the working and protective systems, textile ropes are used with mechanisms that slide along them and lock at the right moment [8,9]. In the working system, the mechanism is used to change the position of the worker, e.g. during his or her descent or ascent, and to keep him or her suspended during work [10]. In the case of the protective system, the main task of its self-clamping mechanism (as per EN 353-2:2005 [11]) is to slide freely along the rope as the user moves up and down and to lock automatically if the user should fall down. In the case of some worksites at height, it is also necessary to perform work in a supported position,

which requires the use of a rope with a manually operated length adjuster [12]. An example of a guided type fall arrester with a flexible anchor line made of kernmantle rope is presented in Figure 1.

The operation of these mechanisms exerts a destructive effect on the rope due to its compression by various types of elements (e.g., those shown in Figure 1) and rope stretching. In the case of kernmantle ropes, the sheath is displaced and often also damaged, e.g., detached around the entire circumference of the rope. Phenomena related to rope damage interfere with the operation of control mechanisms; for instance, they may increase the distance of fall arrest [13–16]. In extreme cases, damage to the sheath may compromise the core, potentially causing a rope break. Examples of damage to kernmantle ropes inflicted by guided type fall arresters are shown in Figure 2.

For the above reason, appropriate ropes should be selected for use with clamping mechanisms, which requires the application of suitable criteria to minimise rope damage. Analysis of the requirements and test methods for kernmantle ropes showed that one of the most important parameters in this respect is sheath slippage [6, 7]. Since none of the

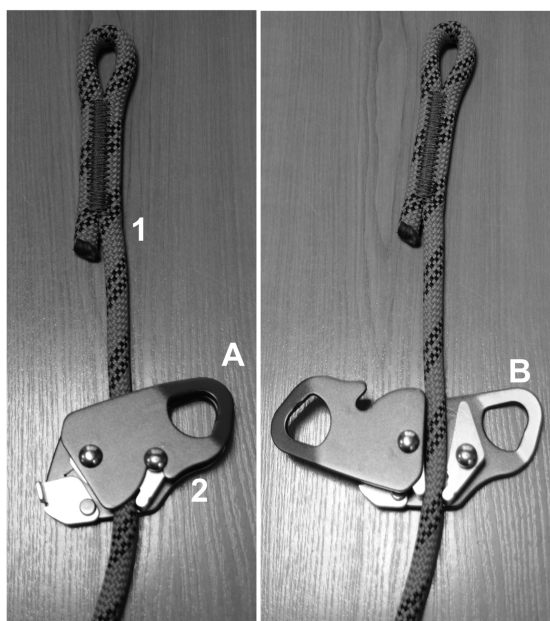

Fig. 1. Guided type fall arrester protecting against falls from height with a flexible anchor line made of kernmantle rope: 1 – flexible anchor line (kernmantle rope), 2 – guided type fall arrester (A – closed, B – open)



Fig. 2. Examples of damage to flexible anchor line

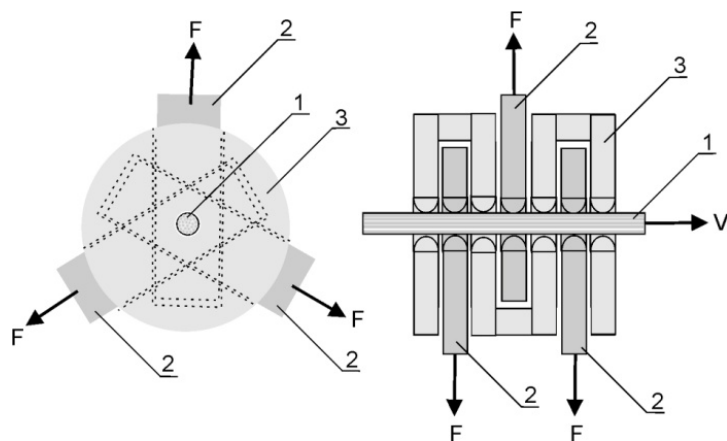

Fig. 3. Diagram of a kernmantle rope loading system for sheath slippage testing [6,7]:  $F$  – loading force,  $V$  – rope movement speed, 1 – kernmantle rope tested, 2 – movable steel plates, 3 – fixed steel plates

accredited testing laboratories in Poland had conducted tests on kernmantle rope sheath displacement to date, in the present study a test stand was built and a test procedure developed for assessing kernmantle ropes of various designs.

## 2. Test method

The standard PN-EN 1891:2002 [6] for low-stretch kernmantle ropes and PN-EN 892+A1:2016 [7] for dynamic climbing ropes present a test method for sheath slippage and set forth the idea of designing a suitable test stand. The test method is based on drawing the rope tested through a system of alternately positioned movable and fixed steel plates, exerting pressure perpendicular to the rope axis. A diagram of the plate layout is shown in Figure 3.

The drawing of the rope tested results in friction between its sheath and the openings in movable and fixed compressing plates. This friction mainly depends on the shape of the openings, the characteristics of their surface, and the force  $F$ . The rope sample to be tested is sealed at one end with a hot knife, while at the other end it is cut in a plane perpendicular to the axis of the rope. As a result of rope compression in five drawing cycles, the sheath gets displaced in relation to the core. This displacement is measured at the non-sealed end of the rope. The sheath moving beyond the length of the core is defined as positive displacement, while the core moving beyond the length of the sheath – as negative displacement.

## 3. Test stand

Guided by the requirements of the standards [6, 7], a stand for testing sheath slippage in kernmantle ropes was constructed, consisting of two basic modules:

- a rope clamping module,
- a drive for pulling the rope through the system of compressing plates.

The design of the module clamping the rope during the test is shown in Figure 4.

The module consists of movable and fixed plates (2) compressing the rope, which are attached to the supporting structure (3). The movable plates are connected by means of a string with weights (4) exerting a force of  $F = (50 \pm 0.5)$  N. The supporting structure (3) is connected to the laboratory floor. The rope tested (1) is pulled through the openings in the plates by means of Kevlar string I (3 mm in diameter), which is attached to its sealed end. This Kevlar string is part of the drive module of the test stand.

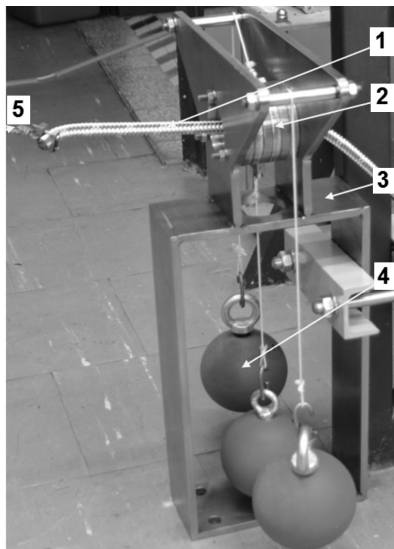

Fig. 4. Design of the rope clamping module: 1 – the rope tested, 2 – movable and fixed plates, 3 – supporting structure, 4 – weights exerting a loading force of  $F = 50$  N on the plates, 5 – Kevlar string I

The design of the movable and fixed plates in the rope compression module is shown in Figure 5.

The dimensions shown in Figure 5 conform to the requirements of the applicable standards [6,7]. Both modules of the test stand, connected by Kevlar string I, are presented in Figure 6. The distance between the modules is approximately 3 m.

The design of the drive module is shown in Figure 7.

The drive module is built into the Zwick testing machine (5). It is supposed to pull string I, connected to the sealed end of the rope tested, at an appropriate speed. The module translates the linear traverse speed of the machine into the rotational movement of the roller (4) by means of Kevlar string II (3). The roller (4) is rigidly connected to the reel (2) on which the Kevlar string I is wound. As a result, the speed of the string I depends on the traverse speed of the Zwick testing machine ( $V$ ) and the gear ratio resulting from the difference between the diameters of the reel (2) and the roller (4). The traverse speed  $V$  is set by means of control software.

#### 4. Verification tests

The test stand was subjected to verification tests in terms of three basic quantities directly affecting the measurement of sheath slippage:

- the pulling forces of the movable plates in the rope compression module,
- the movement of the rope tested through the compression module,
- the speed of the rope tested in the compression module.

The pulling forces of the plates were investigated by installing in series with them a Megatron KT1400K force transducer with a measurement range of 500 N. The mass of the weights (4), shown in Figure 4, was adjusted according to readings from the force measuring apparatus. In this way, the frictional resistance of the rollers of the weight strings was compensated (see Figure 4). As a result, the forces acting on the movable plates of the compression module were set in the range of  $F = (50 \pm 0.1)$  N.

The magnitude of displacement of the rope tested by the compression module was verified using a tape measure. The results obtained were demonstrated to depend not only on the displacement of the testing machine traverse but also on the mechanical properties of the string, and especially its elasticity. The tests conducted showed that the traverse shift in the testing machine should be determined each time for a particular type of rope in preliminary tests.

The speed of the rope tested moving through the compression module was measured using a Mikrotron MotionBlitz

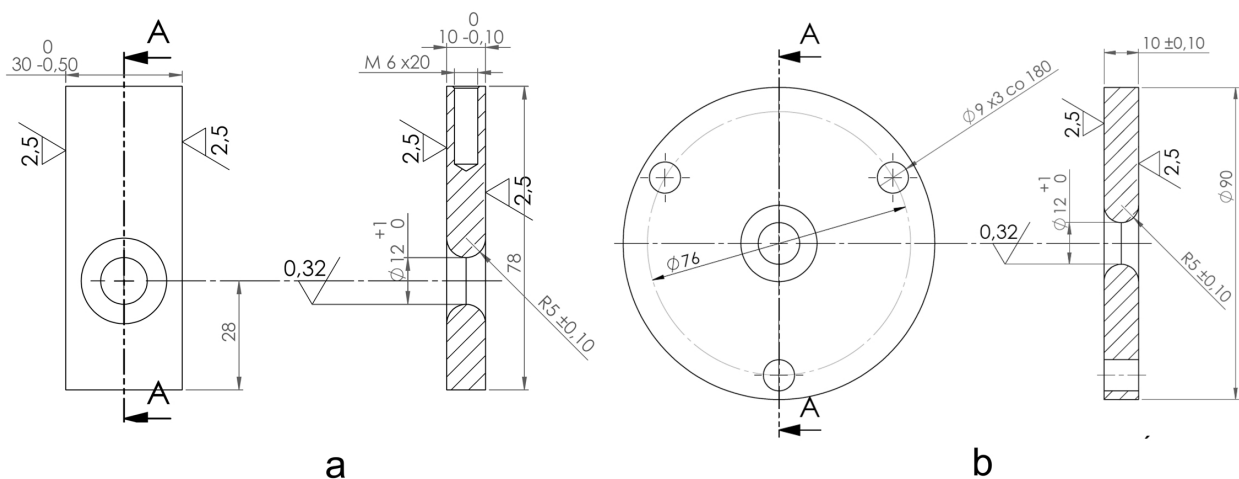

Fig. 5. Sample design of plates on a stand for testing sheath slippage in kernmantle ropes: a – movable plate, b – fixed plate

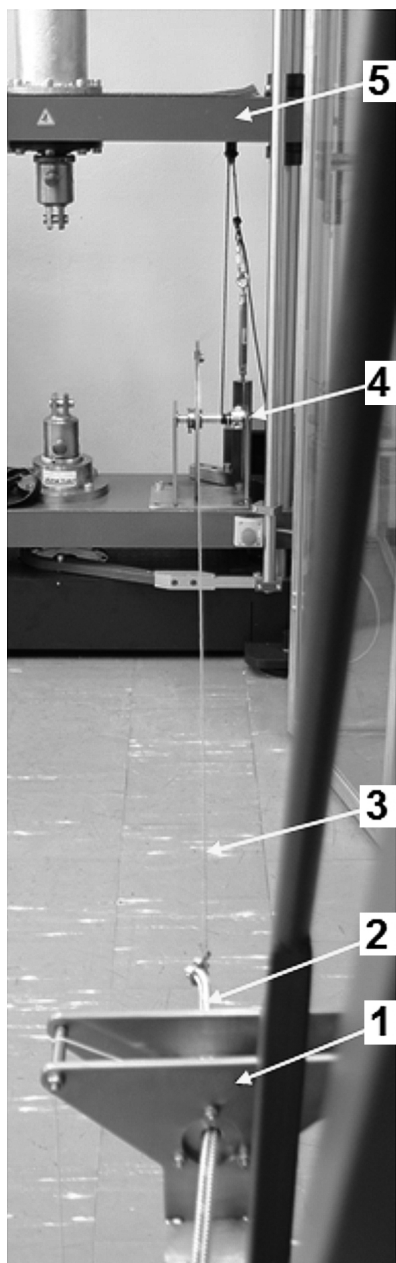

Fig. 6. Stand for testing sheath slippage in kernmantle ropes: 1 – rope compression module, 2 – rope tested, 3 – Kevlar string I, 4 – drive module, 5 – Zwick testing machine

EoSens Cube7 digital camera and software [18]. The camera, recorded the movement of the point connecting the rope tested to the Kevlar string I, and then the recording was digitally processed to create a graph presenting the rope speed over time. Sample test results are presented in Figure 8.

The diagram clearly shows rope speed oscillations. This effect is due to the elasticity of both the object tested

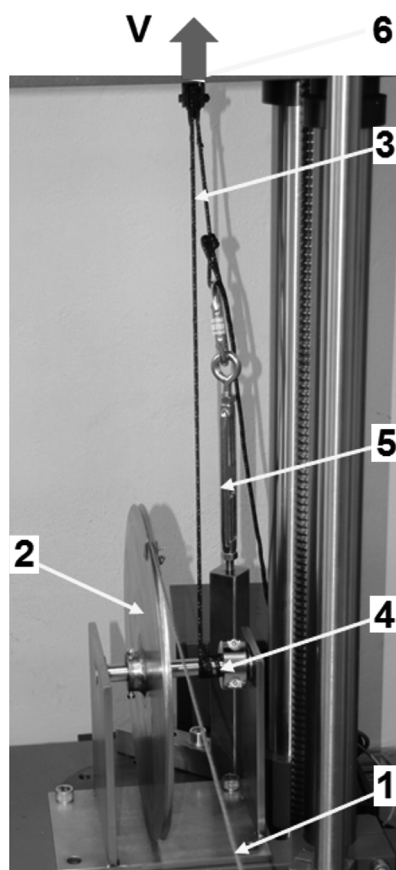

Fig. 7. Drive module of the stand for testing sheath slippage in kernmantle ropes: 1 – Kevlar string I, 2 – string I reel, 3 – Kevlar string II, 4 – string II roller, 5 – string II tensioner, V – traverse speed of the Zwick testing machine

(kernmantle rope) and Kevlar strings I and II. Tests carried out on samples made of kernmantle ropes with diameters from 9 to 12 mm showed that the results obtained fall within the required limits, i.e.,  $(50 \pm 20)$  mm/s (6), provided that the control settings of the testing machine are selected experimentally for each type of rope.

Summing up the experiments conducted, the test method and test stand constructed were found to be in conformity with the requirements set forth in the applicable standards [6,7], which enabled the testing of kernmantle ropes of various designs.

## 5. Kernmantle rope tests

Eleven types of kernmantle ropes were selected for tests aimed at further verification of the method and the test

stand, as well as at obtaining data on kernmantle ropes used both in industrial conditions and for sports and recreational purposes (the ropes are listed in Table 1 and shown in Figure 9). These kernmantle ropes were of various designs, braided, both low-stretch and dynamic, with diameters ranging from 8.1 to 13.5 mm.

Before the tests, the ropes were kept at a temperature of 21°C and relative humidity of 66% for 72 hours, and then tested at 24°C. After five cycles of drawing through the compression module, the displacement of the sheath relative to the core was measured using a caliper. Examples of sheath slippage are presented in Figure 10.

Table 1 presents the results of the completed study in the form of average values from five tests and standard deviations. Figure 11 shows the results graphically.

## 6. Summary and conclusions

The construction of the sheath slippage test stand presented (and especially the rope compression module) meets the basic requirements laid out in the applicable standards [6,7] for kernmantle ropes. The stand verification tests also demonstrated its compliance with the requirements of the standards in terms of the rope drawing speed, rope displacement, and the pressure exerted on the rope by the movable plates of the compression module.

Tests of 11 types of kernmantle ropes showed both negative and positive sheath slippage. Results for individual types of rope exhibited some variation, but always had the same sign. This means that positive/negative displacement is not a random effect, but rather an inherent feature of rope design. The test results presented in Table 1 indicate a relatively high value of the coefficient of variation for standard deviation, which directly affects the random component (A) of measurement uncertainty [18]. Given that rope samples for testing were taken from the same reel, it should not be expected that the dispersion of results

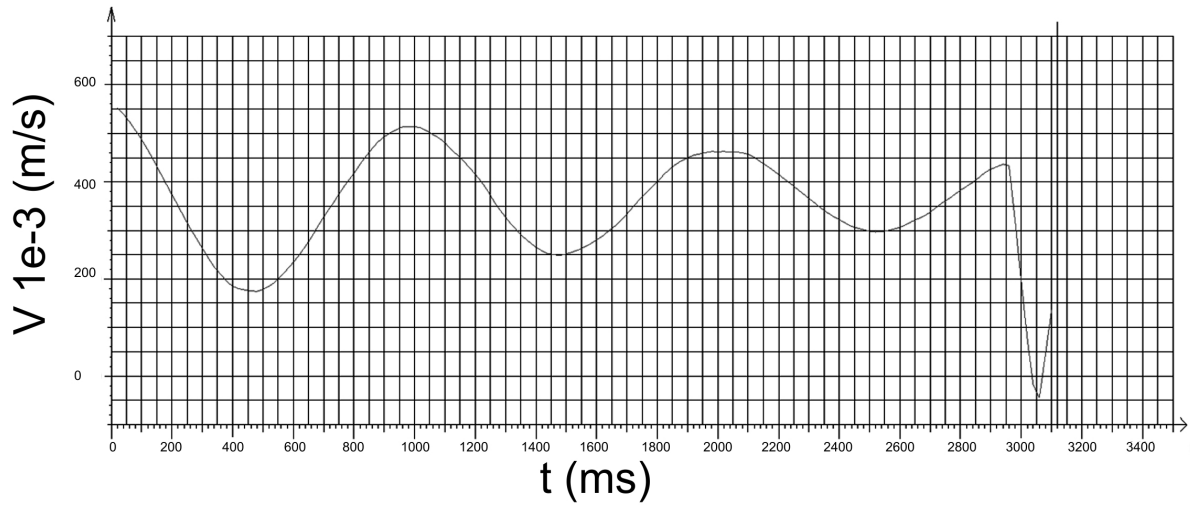

Fig. 8. Speed of the test rope moving through the compression module over time

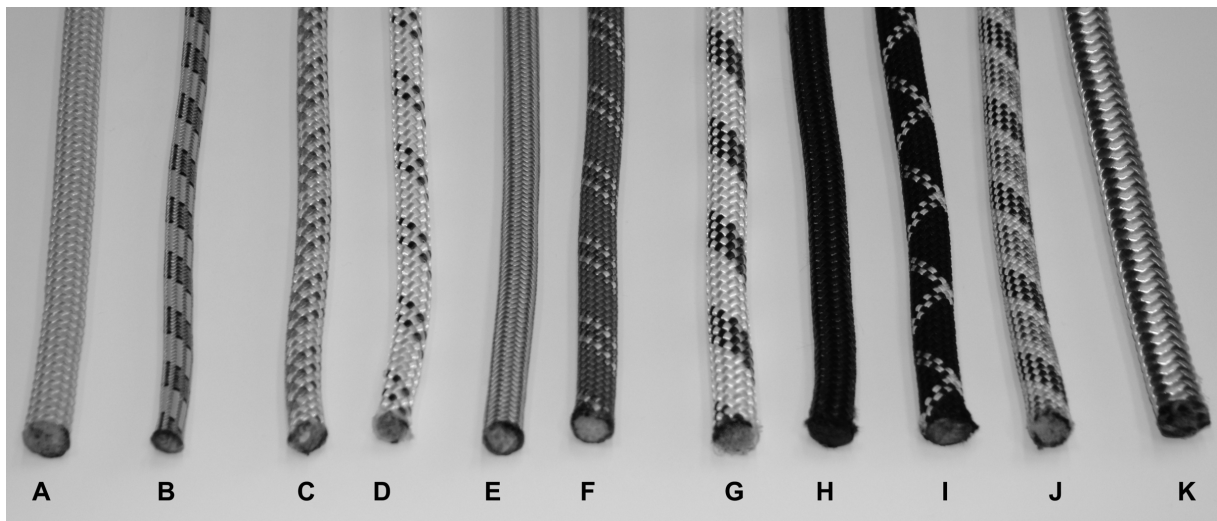

Fig. 9. Kernmantle ropes subjected to sheath slippage tests

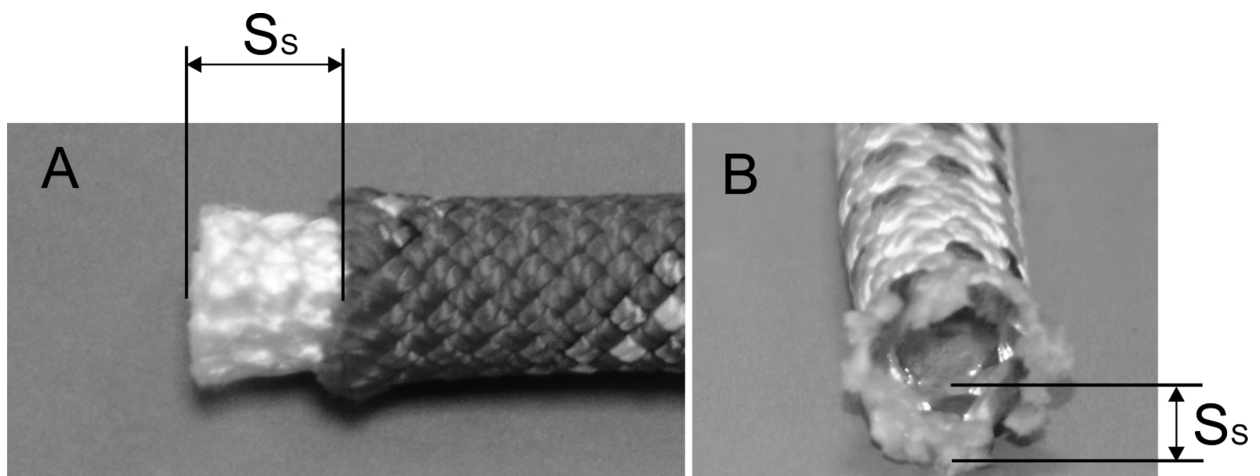

Fig. 10. Sample results of kernmantle rope sheath slippage tests: A – negative displacement, B – positive displacement

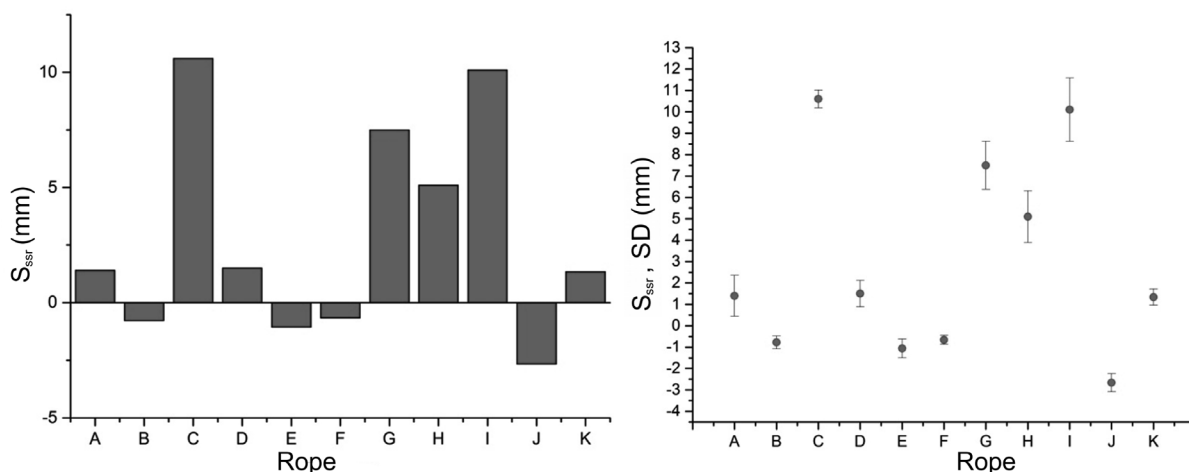

Fig. 11. Results of kernmantle rope sheath slippage tests

Rope symbol	Rope type	Rope diameter $d$ [mm]	Mean sheath slippage $S_{Sm}$ [mm]	Standard deviation SD [mm]	Coefficient of variation for SD $W_{sx}$ [%]
A	Titan 11	11	1.4	0.96177	68.7
B	Iceline	8.1	-0.78	0.30332	38.9
C	Aqualine	9.5	10.6	0.41833	3.9
D	Pro-Static	10	1.5	0.61237	40.8
E	Wall master VI	10.5	-1.06	0.43932	41.4
F	Apollo II	11	-0.66	0.20736	31.4
G	Performance Static	12	7.5	1.11803	14.9
H	Pes 12-K-24	12	5.1	1.20623	23.7
I	Pa-200-12-K 24x2	12	10.1	1.48155	14.7
J	Tendon	11	-2.66	0.4219	15.9
K	Baobab Uni Core	13.5	1.34	0.37815	28.2

Table 1. Kernmantle ropes subjected to sheath slippage tests and the results obtained

is attributable to the variability of rope parameters. Instead, analysis of the test method indicates that this dispersion may result from the final measurement of core displacement in relation to the sheath. This is due to the fact that after five cycles of drawing through the rope compression module, the end of the rope sheath is slightly unraveled, and the end of the core does not form an even, flat surface. Therefore, it will ultimately be necessary to measure the displacement of the core relative to the sheath using a caliper at various points around the perimeter of the rope cross-section. This measurement should be repeated, e.g., 5

times, and the average value should be given as the result. In summary, the test stand constructed can successfully assess kernmantle ropes in terms of a parameter that is important to the safety of users of individual fall protection equipment.

Assessing the results obtained from the point of view of the applicable standards [6,7], it can be concluded that the ropes tested meet the requirements for sheath slippage parameters.

This paper was based on the results of a research task carried out within the fifth stage of the National Programme

“Improvement of safety and working conditions” partly supported in 2021–2022 — within the scope of state services — by the Minister responsible for labour — by the Minister responsible for labour (task no. 3.SP.03 entitled ‘Development of the principles of application and testing methodology for equipment intended for simultaneous protection against falls from a height and work in suspension using the rope access technique’). The Central Institute for Labour Protection – National Research Institute is the Programme’s main co-ordinator.

## References

1. Standard No. EN 363:2018. European Committee for Standardization (CEN). (2018). Personal fall protection equipment. Personal fall protection systems. Brussels, Belgium.
2. Becker K. Ropes in fall protection systems. In: Fundamentals of fall protection. Ed. Sulowski AC. Toronto, Canada: International Society for Fall Protection; 1991: 357 – 362.
3. Baszczyński K, Jachowicz M, Jabłońska A. Development of the principles of application and testing methodology of equipment intended for simultaneous protection against falling from a height and work in suspension using the rope access technique (in Polish). Report on task 03.SP.03 implemented under the multiannual program V. CIOP-PIB, 2021.
4. Lwow A. Liny alpinistyczne. [Climbing ropes]. Copyright by Aleksander Lwow. 1992.
5. Seddon P. Harness suspension: review and evaluation of existing information. Health and Safety Executive (HSE), CONTRACT RESEARCH REPORT 451/2002. Available from: [https://www.hse.gov.uk/research/crr\\_pdf/2002/crr02451.pdf](https://www.hse.gov.uk/research/crr_pdf/2002/crr02451.pdf).
6. Standard No. EN 1891:1998. European Committee for Standardization (CEN). (1998). Personal protective equipment for the prevention of falls from a height - Low stretch kernmantel ropes. Brussels, Belgium.
7. Standard No. EN 892:2012+A1:2016. European Committee for Standardization (CEN). (2012). Mountaineering equipment - Dynamic mountaineering ropes - Safety requirements and test methods. Brussels, Belgium.
8. Sulowski AC. Fall protection Systems - classification. In: Fundamentals of fall protection. Ed. Sulowski AC. Toronto, Canada: International Society for Fall Protection; 1991: 285 – 301.
9. Sulowski AC. Fall arresting systems – selection of equipment. In: Fundamentals of fall protection. Ed. Sulowski AC. Toronto, Canada: International Society for Fall Protection; 1991: 303 – 320.
10. Standard No. EN 12841:2006. European Committee for Standardization (CEN). (2006). Personal fall protection equipment - Rope access systems - Rope adjustment devices. Brussels, Belgium.
11. Standard No. EN 353-2:2002. European Committee for Standardization (CEN). (2002). Personal protective equipment against falls from a height – Self locking arrester on flexible anchorage line. Brussels, Belgium.
12. Standard No. EN 358:2018. European Committee for Standardization (CEN). (2018). Personal protective equipment for work positioning and prevention of falls from a height - Belts and lanyards for work positioning or restraint. Brussels, Belgium.
13. Baszczyński K, Jachowicz M. Effect of Mechanical Factors on the Protective Parameters of Textile Elements in Personal Equipment Protecting Against Falls from a Height. *FIBRES & TEXTILES in Eastern Europe* 2011; 19, No. 5(88): 117 – 124.
14. Baszczyński K. Effect of Repeated Loading on Textile Rope and Webbing Characteristics in Personal Equipment Protecting Against Falls from a Height. *FIBRES & TEXTILES in Eastern Europe* 2015; 23, 4(112): 110-118. DOI: 10.5604/12303666.1152741.
15. Baszczyński K, Zrobek Z. Effect of atmospheric conditions on the operation of self-clamping devices with flexible guides (in Polish). *Bezpieczeństwo Pracy – Nauka i Praktyka*. 2000; issue 6: 17-19.
16. Baszczyński K, Jachowicz M. Load-Elongation Characteristics of Connecting and Shock-Absorbing Components of Personal Fall Arrest Systems. *FIBRES AND TEXTILES in Eastern Europe*. 2012; 20, No. 6A(95): 78 – 85.
17. Image Systems AB. Image Systems Motion Analysis. Available from: <http://www.imagesystems.se/tema/motion/>.
18. Working Group 1 of the Joint Committee for Guides in Metrology: Evaluation of measurement data — Guide to the expression of uncertainty in measurement. JCGM. 2008.