

## RESEARCHES ON THE AMOUNT OF RECUPERATED ENERGY BY ELECTROMAGNETIC SHOCK ABSORBER IN SMALL CAR

Krzysztof Siczek, Maciej Kuchar

Technical University of Lodz  
Department of Vehicles and Fundamentals of Machine Design  
Zeromskiego Street 116, 90-924 Lodz, Poland  
tel.: +48 42 6312250, +48 42 6312255, fax: +48 42 6312252  
e-mail: ks670907@p.lodz.pl, maciej.kuchar@p.lodz.pl

### Abstract

*The weight decreasing of small cars can be very effective by using of lightweight materials. Movable masses of such cars like suspension arms, wheel rims, drive shafts can be made of magnesium alloy, brake discs can be made of aluminum alloy. Such masses can mate with electromagnetic shock absorbers with possibility of recuperation for energy of chassis vibrations, changing it into the useful electric power. Main parts of the shock absorber are the cylinder with the set of coils and the rod with a set of permanent magnets. Cylinder can be made of magnesium alloy. Coils winding has been connected to electric wires placed inside light spring. Three-phase current generated in the set of coils can be supplied through the controlled rectifier into battery. Dimensions of electromagnetic shock absorber have been close to those of hydraulic shock absorber, so it can be used in the typical chassis of automobile. The scheme of the shock absorber has been shown in the article. The elaborated model of road roughness and of moving masses for small car, connected to electromagnetic shock absorber has been shown in the article. It has been analysed the values of dynamic parameters during operation of electromagnetic shock absorber with movable masses of small car driven in different road conditions. Results of such analysis have been presented in the article. The aim of the study has been to estimate and to compare the amount of recuperated energy by the electromagnetic shock absorber – rectifier – battery assembly for the cases of car movable masses made of steel and for the one of lightweight materials.*

**Keywords:** *small car, shock absorber, energy recuperation, permanent magnets*

### 1. Introduction

The automobile moving on the rough road is loaded by stochastic vertical inputs, which act on its wheel. All of such inputs are independent of each other. Their intensity is proportional to the vehicle speed, almost linearly. Such inputs acting on the automobile wheels initiate vibrations during driving, which are felt by the driver or passengers as a kind of discomfort. Therefore, vehicle designers try to isolate these vibrations from the body by a set of springs and to damp them by a set of shock absorbers, usually one shock absorber falls on one wheel. In most cases, hydraulic shock absorbers are used in which the energy of vehicle vibrations is precipitated on the flow of hydraulic fluid through the system throttling valves. The energy of the fluid is converted into the heat and into the work for overcoming the flow resistance and, therefore, is lost forever.

Such energy, however, may be changed into the useful electric power, with the help of additional generator [1, 4]. This energy can be used to charge the battery and to improve the efficiency of the drive.

At least part of the energy may be recovered, without significant decreasing the level of vibration damping, which is provided in most vehicles by classic hydraulic shock absorbers.

The object of researches presented in the paper has been a set of magnetoelectric shock absorber with possibility of electric power recuperation.

The aim of the present paper is to investigate an amount for performance of the new shock absorber for different speed of automobile and road conditions.

## 2. Description of the new shock absorber with energy recuperation

The scheme of electromagnetic shock absorber has been shown in Fig. 1. It has consisted of a linear synchronous generator with permanent magnets, springs and battery of power [6].

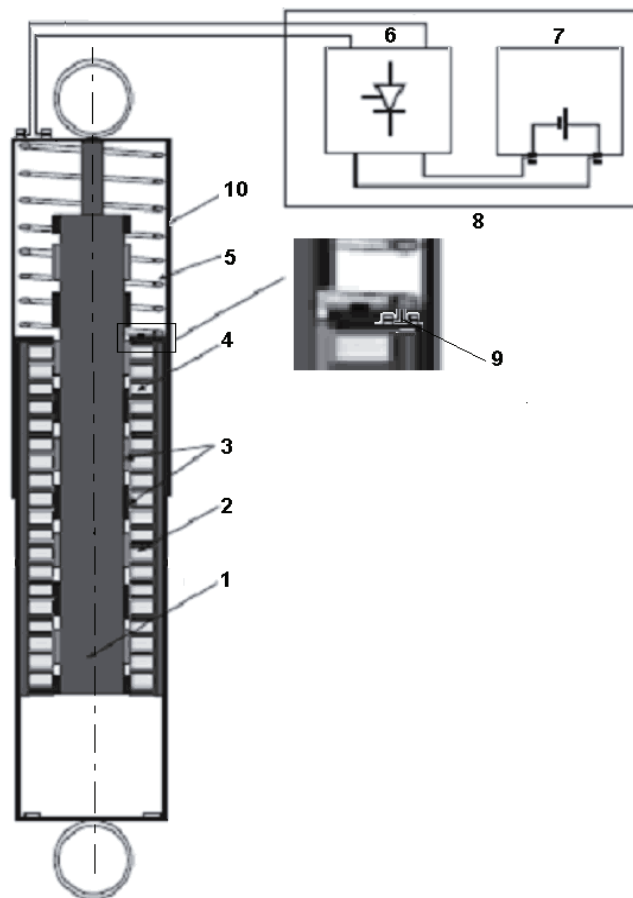

Fig. 1. Electromagnetic shock absorber: 1 – rod with permanent magnets, 2 – cylinder with set of coils, 3 – permanent magnets, 4 – coil, 5 – hollow spring with electric wires inside, 6 – controlled rectifier, 7 – battery, 8 – energy storage, 9 – wiring terminals, 10 – cover

A linear generator has consisted of two parts:

- Rod 1 with the set of permanent magnets 3 attached to the iron core,
- Cylinder 2 with three-phase windings 4 placed in the slots of the cylinder 2.

Cylinder 2 has been pushed by light spring 5 made of hollow wire. The electric wires, fixed to their terminals 9 have been placed inside the spring. The energy storage 8 consists of a controlled rectifier 6 and the associated battery 7.

During vibrations of car suspension, the cylinder 2 moves relative to the rod 1. Due to the relative linear movement of the coil winding 4 and the permanent magnets 3, an alternating voltage is induced in the coils 4. This voltage is then rectified by a three-phase controllable rectifier and supplied to the battery. Because the magnetic field generated by the permanent magnets varies in relation to the cylinder, the core of this part should be laminated to reduce eddy current losses and hysteresis losses. The rod core can be made of solid iron, since the magnetic flux is fixed in it.

Taking into account the topology of the shock absorber, its cylinder should be shorter than the rod in order to ensure constant active length of the machine. Such configuration makes the shock absorber lighter and cheaper than for one with a longer cylinder against a shorter rod.

The rod is made of solid ferromagnetic steel with permanent magnets placed on its outer surface. The cylinder has been of slot design. Three-phase stator windings are arranged in the slots.

The cylinder of the shock absorber can be made of elongated sheets or disc-shaped sheets, as in the linear induction machine. Laying of disc-shaped sheets increases the efficiency of the air gap between outer surface of magnets and inner surface of the cylinder.

In the shock absorber one part is fixed and the other movable. A disadvantage of the movable rod is that the permanent magnets are subjected to continuous vibration, which can make them demagnetized. It is preferable to have a longer rod than the cylinder because in the shorter cylinder it can be kept minimal amount of winding in relation to the active surface. Therefore, it has been made a compromise between maximizing the active surface and reducing costs. The longer the cylinder, the greater the loss of energy.

If the coil is placed in the open slots, the effective air gap becomes much larger than the actual air gap. On the other hand, the lower non-ferromagnetic air gap requires less of a permanent magnet material. In the case of slot design, the flux density is higher and current less than in the case of slotless design. Magnetic field strength in the air gap of the generator of slot design is greater than in the case of slotless generator. It allows generating a higher voltage at the same oscillating motion and, consequently, more energy will be sent to the battery, which means that the damping coefficient value for shock absorber can be higher. Considered structure of permanent magnets placed on the outer surface of rod can result in greater air gaps, with the result that the armature reaction is reduced. To ensure adequate clearance air gap has been greater than in a conventional rotary machine.

A linear generator can be excited by a field from permanent magnets. Operating conditions of such generator depend not only on the permanent magnets, but also on the entire magnetic circuit. They also depend on how the magnets are installed and whether the circuit is magnetized before or after installation.

### 3. The model of road roughness and of moving masses for vehicle

The road quality is usually evaluated on the base of the spectral power density for road micro profile. The representative model of analysed road roughness has been established, basing on the data from [3, 7].

The spectral density of road roughness, for different surface conditions has been shown in Fig. 2. Basing on such values and using Inverse Fast Fourier Transform, the road profile samples have been generated (Fig. 3).

Such values have been used for the excitation of the wheel in the model of moving vehicle.

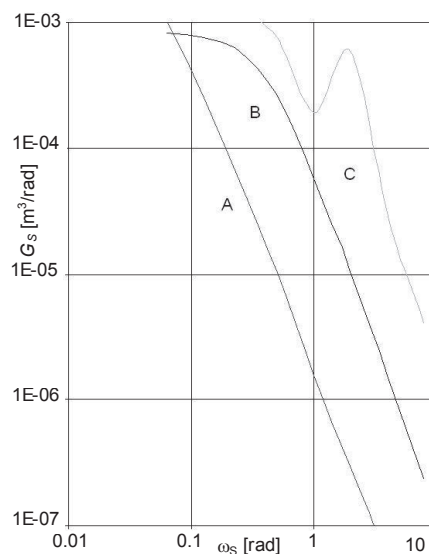

Fig. 2. The spectral density of road roughness  $G_s$  vs. relative frequency  $\omega_s$ : A – asphalt surface in good conditions, B – asphalt surface in poor conditions set of poles, C – paved surface

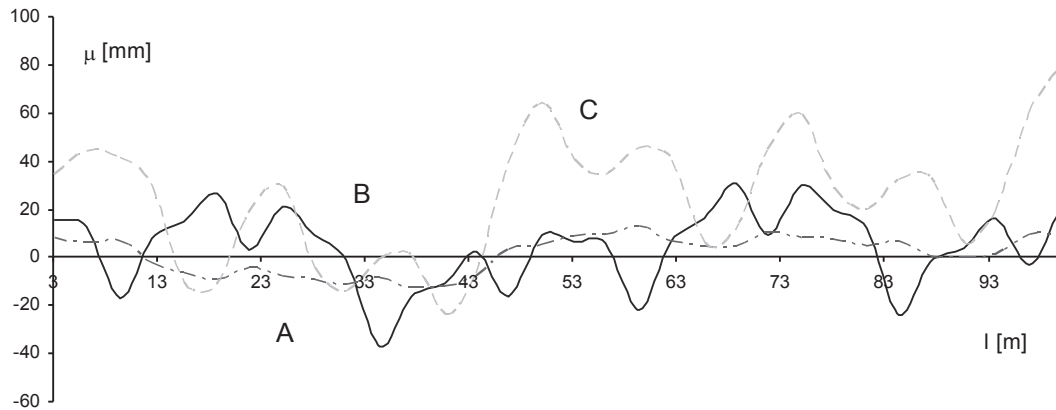

Fig. 3. Road micro profile  $\mu$  (samples generated basing on values of their spectral power density) vs. road length  $l$ : A – asphalt surface in good conditions, B – asphalt surface in poor conditions, C – paved surface

#### 4. The model of movable masses for vehicle

It has been analysed the small car with McPherson columns. The chassis and the body of the car and its wheels have been modelled as the set of two vibrating masses (Fig. 4) and such model has been used in the paper. Such set has been of two degree of freedom. The first mass has been the wheel with the stiffness and damping of its tire. The second mass has been equal 1/4 of all vehicle mass and it has been associated with the stiffness of the wheel spring and with the nonlinear damping of wheel shock absorber. The characteristic data have been taken from [2, 5, 8].

It has been considered two sets of movable masses (Fig. 5). The first set contain wheel with tire of usual profile, brake calliper made of ductile cast iron, and suspension arm and other movable elements made of steel. The second set contain wheel with tire of low profile providing the greater stiffness, the wheel rim made of AlSi alloy, brake calliper made of AlSi alloy, and suspension arm and drive shaft made of magnesium alloy and other movable elements made of steel.

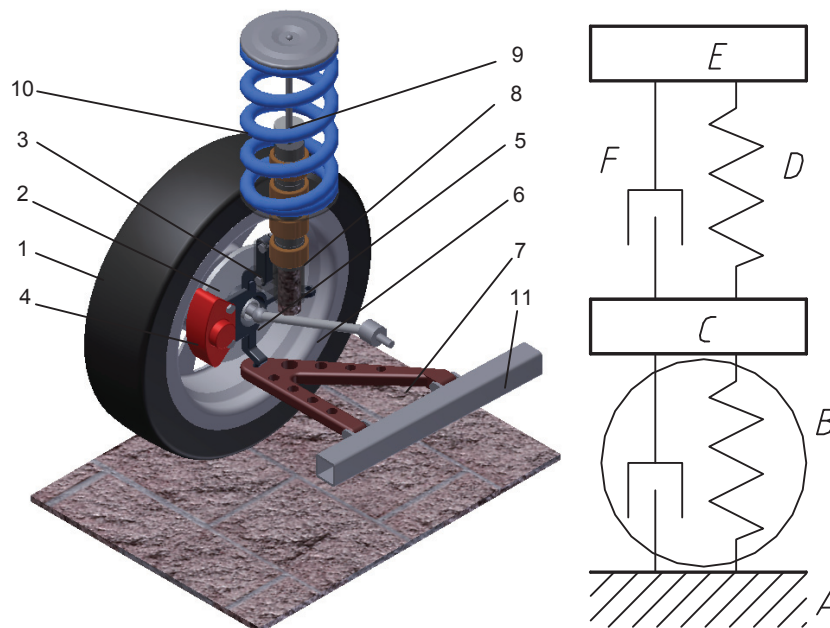

Fig. 4. McPherson column treated as a set of two degrees of freedom: 1 – wheel, 2 – brake disc, 3 – steering, 4 – clamp, 5 – joint, 6 – drive axle, 7 – arm, 8 – stator of generator cylinder of shock absorber, 9 – rod with permanent magnets, 10 – spring, 11 – car body; A – excitation (vibrations) from road profile, B – tire (stiffness increasing from 100 to 200 N/mm, damping coefficient 0.15 N·s/mm), C – unsprung mass, D – spring (stiffness 28 N/mm), E – 1/4 of mass of vehicle (250 kg), F – shock absorber (nonlinear damping coefficient)

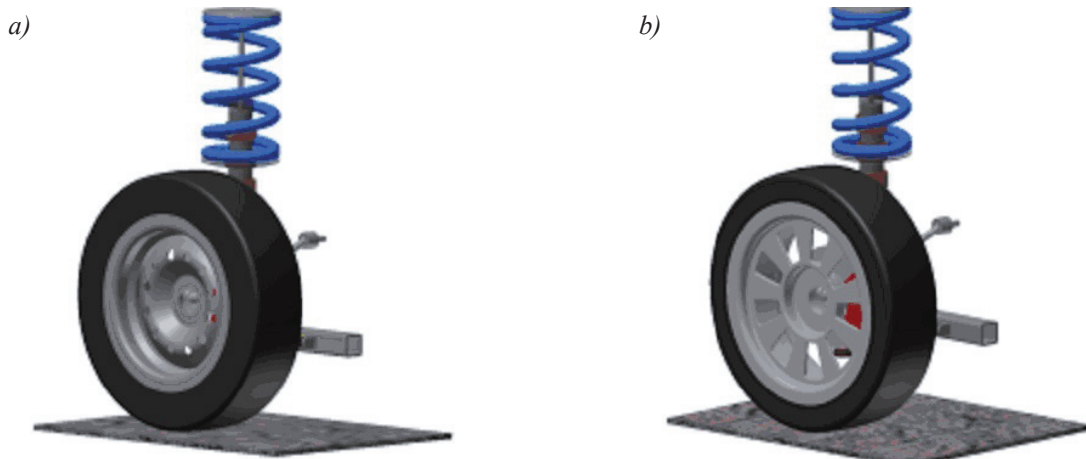

Fig. 5. Considered wheel with the steel rim (a), and the rim made of AlSi alloy (b)

Parameters used in simulation model have been shown in Tab. 1 (movable masses) and in Tab. 2 (stiffness and damping coefficient for used joints). Values presented in Tab. 1 have been calculated for elements of the typical small car. Values presented in Tab. 2 have been based on the data from [2, 5, 8].

Tab. 1. Movable masses

Movable masses for simulation model	Steel rim [kg]	AlSi rim [kg]
Wheel, steering knuckle, brake disc, clamp, joint, stator of motor (cylinder of the shock absorber)	13.37	8.43
Suspension arm	2.14	0.74
Drive shaft	0.18	0.06
Spring	3.06	3.06
The assembly piston rod of shock absorber – set of permanent magnets	7.25	7.25
1/4 weight of automobile	250	250

Tab. 2. Used parameters of joints [2, 5, 8]

Type of joint	Stiffness [N/mm]	Damping coefficient [N·s/mm]
Reciprocating for the rod of shock absorber	30	3 / 1.8
Reciprocating for the wheel	150 / 250	0.6 / 0.2

## 5. Results of the dynamical analysis for the set of movable masses

It has been provided dynamical analysis for the modelled assembly of movable masses of the small car. First into the modelled assembly, it has been applied the unit excitation with the shape of half-sinus function with the frequency  $f=2$  Hz and the amplitude  $A=50$  mm. The obtained dynamic answer of the assembly to the unit excitation, for the different values of damping coefficient, have been presented in Fig. 6 for the case of the steel rim. Analogical courses have been shown in Fig. 7 for the case of the rim made of AlSi alloy.

With the increase of values of damping coefficient the displacement of the car body are damped slightly quicker in the case of the rim made of AlSi alloy than in case of the steel rim. However, from the other hand, displacements of the wheels are damped slightly slower.

At the same value of damping coefficient  $c=3$ , the maximum displacement of car body against time has been smaller up to 4% in case of the steel rim than in case of the rim made of AlSi alloy.



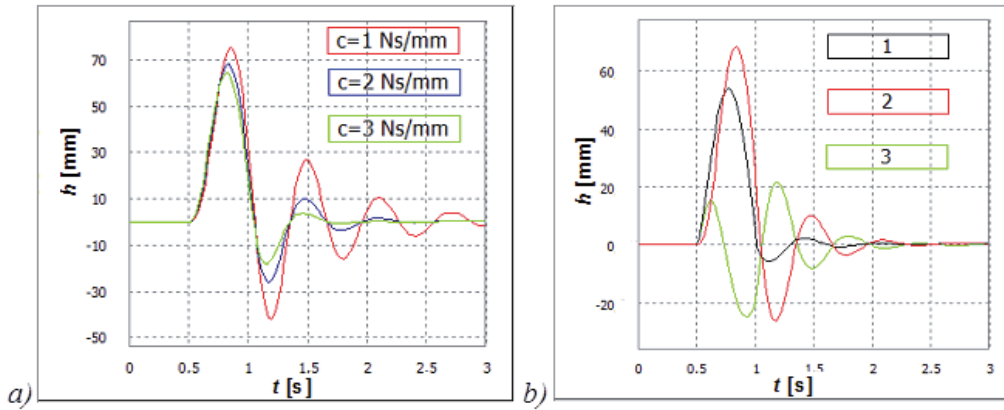

Fig. 6. The dynamic answer of the assembly to the unit excitation for the case of the steel rim: displacement of car body vs. time for different values of damping coefficient (a), and displacement of car body vs. time for the damping coefficient  $c = 3$  (b): 1 – displacement of the wheel, 2 – displacement of the car body, 3 – displacement of the rod of shock absorber

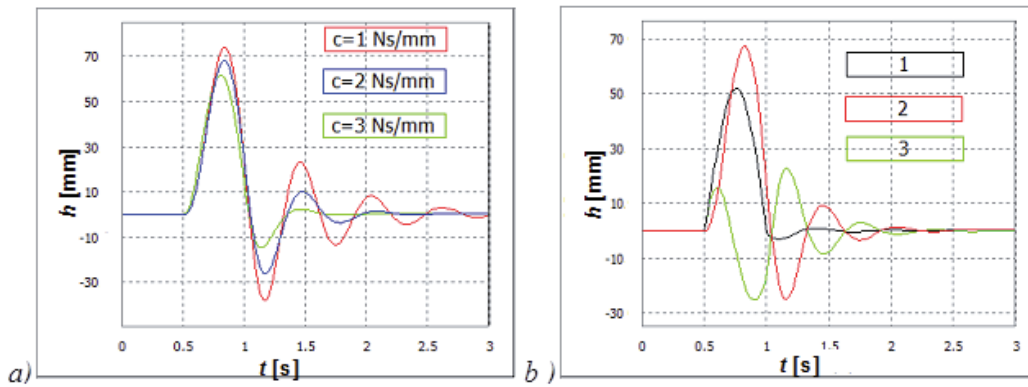

Fig. 7. The dynamic answer of the assembly to the unit excitation for the case of the rim made of AlSi: displacement of car body vs. time for different values of damping coefficient (a), and displacement of car body vs. time for the damping coefficient  $c = 1.8$  (b): 1 – displacement of the wheel, 2 – displacement of the car body, 3 – displacement of the rod of shock absorber

### 6. Power dissipated in the generator of the shock absorber

Courses of variables against time, pointed by: 1 – for the power of generator in shock absorber, 2 – for the velocity of the rod the shock absorber and 3 – for the force generated in the shock absorber respectively have been presented in Fig. 8a for the case of the steel rim and in Fig. 9a for the case of the rim made of AlSi alloy. Phase diagram displacement – velocity of the rod relative to the cylinder have been presented in Fig. 8b for the case of the steel rim and in Fig. 9b for the rim made of AlSi alloy.

Mean values of the power dissipated in the generator of the shock absorber have been shown in Fig. 10a for the steel rim and in Fig. 10b for the rim made of AlSi alloy.

Generated power in shock absorber has been greater up to 15% in case of the rim made of AlSi alloy than in case of the rim made of steel. Obtained values of force generated in shock absorber have been smaller up to 25%, but relative velocity of its rod against its cylinder have been greater up to 30% in case of the rim made of AlSi alloy. The sustainability of magnetolectric shock absorber has not been fully determined yet. It can be slightly lower than that of hydraulic one.

### 7. Summary

Generated power in shock absorber depends on conditions of road surface and of movable masses. It has been greater in case of the rim made of AlSi alloy when driving in good asphalt road but for paved road such power have been smaller than in case of the rim made of steel. Obtained

values of force generated in shock absorber have been smaller, but relative velocity of its rod against its cylinder has been greater about several percent in case of the rim made of AlSi alloy.

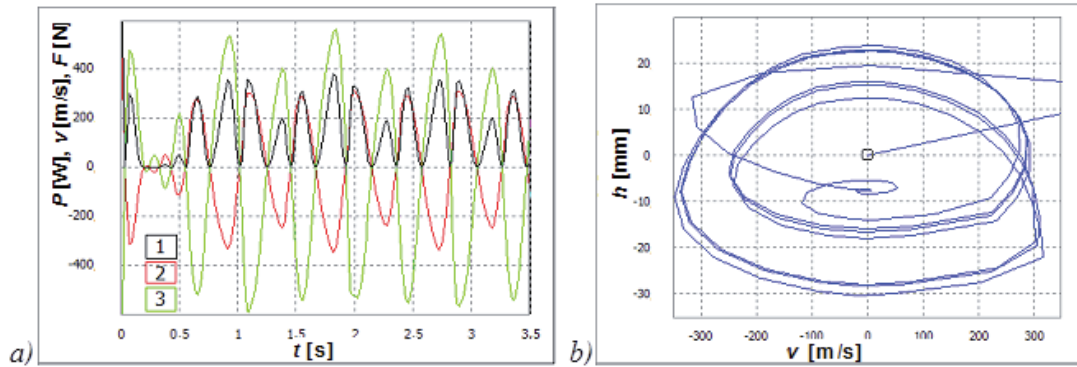

Fig. 8. Courses against time for: 1 – the power of generator in shock absorber, 2 – velocity of the rod the shock absorber, 3 – force generated in the shock absorber (a). Phase diagram displacement – velocity of the rod relative to the cylinder, the case of the wheel with steel rim (b)

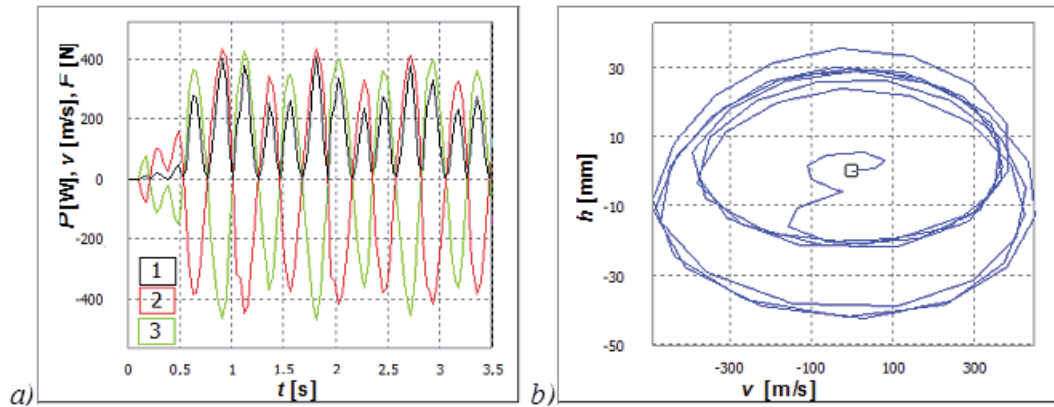

Fig. 9. Courses against time for: 1 – the power of generator in shock absorber, 2 – velocity of the rod the shock absorber, 3 – force generated in the shock absorber (a). Phase diagram displacement – velocity of the rod relative to the cylinder, the case of the wheel with the rim made of AlSi alloy (b)

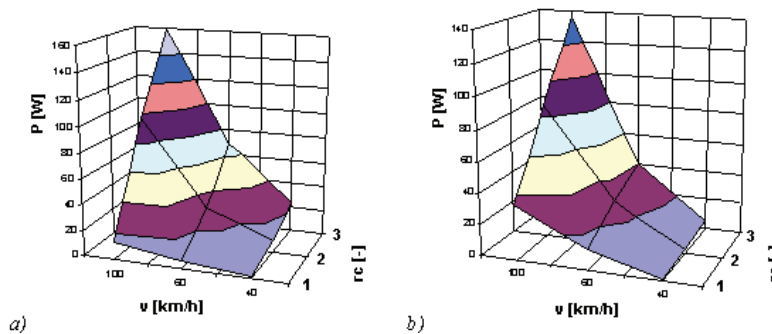

Fig. 10. Mean values of the power  $P$  dissipated in the generator of the shock absorber for the wheel with the steel rim (a), and for the wheel with the rim made of AlSi alloy (b),  $v$  – velocity of the car,  $r_c$  – road conditions, 1 – asphalt surface in good conditions, 2 – asphalt surface in poor conditions set of poles, 3 – paved surface

## References

- [1] Avadhany, S. N., *Analyzes of Hydraulic Power Transduction in Regenerative Rotary Shock Absorber as Function of Working Fluid Kinematic Viscosity*, S. B. Materials of Science and Engineering Massachusetts Institute of Technology, 2009.

- [2] Emam, M. A. A., Shaaban, S., El-Demerdash, S., El-Zomor, H., *A Tyre-Terrain Interaction Model for Off-Road Vehicles*, Journal of Mechanical Engineering Research, Vol. 3, No. 7, pp. 226-238, 2011.
- [3] Kamiński, E., Pokorski, J., *Dynamika zawieszzeń i układów napędowych pojazdów samochodowych*, WKiŁ, Warszawa 1983.
- [4] Kuchar, M., Siczek, K., *Evaluation of Possibility for Recovering of Energy from the Suspension Using Air Shock Absorber*, The Archives of Automotive Engineering, No. 2, pp. 21-37, 2011.
- [5] Rao, M. D., Gruenberg, S., *Measurement of Equivalent Stiffness and Damping of Shock Absorbers*, Michigan Technological University, Houghton, MI 49931, USA.
- [6] Mendrela, E., Drzewoski, R., *Electric Shock Absorber for Electric Vehicles*, Conference Proceedings of BASSIN'2000, Lodz, Poland 2000.
- [7] Sayers, M. W., Karamihas, S. M., *The Basic Information and Measurement Road Profiles*, University of Michigan, 1998.
- [8] Ślaski, G., Pikosz, H., *Wpływ zmian tłumienia w zakresie zmienności charakterystyki amortyzatora na pionowe obciążenia dynamiczne kół*, Transcomp – XIV International Conference Computer Systems Aided Science, Industry and Transport, pp. 3479-3487, 2012.