

Wojciech HORAK\*, Marcin SZCZĘCH\*\*

## THE ANALYSIS OF THE WORKING CONDITIONS OF A THRUST SQUEEZE BEARING WITH A MAGNETORHEOLOGICAL FLUID OPERATING IN THE OSCILLATORY COMPRESSION MODE

### ANALIZA WARUNKÓW PRACY WZDŁUŻNEGO ŁOŻYSKA Z CIECZĄ MAGNETOREOLOGICZNĄ PRACUJĄCEGO W WARUNKACH ŚCISKANIA OSCYLACYJNEGO

**Key words:**

magnetorheological fluid, thrust bearing, testing, oscillatory compression, normal force.

**Abstract**

The operating state of thrust plain bearings is a function of many parameters, both geometric and related to load conditions. Besides the methods of controlling bearings of this type used so far, new possibilities of modelling their operating characteristics by using substances with controlled rheological properties as a lubricant can be pointed out. Magnetorheological fluids create such a possibility. These are suspensions of particles with magnetic properties in a carrier fluid (usually in mineral or synthetic oil). The influence of magnetic field on this type of fluids changes their rheological properties. This process is almost instantaneous and fully reversible.

The paper presents the results of investigations of a thrust squeeze bearing lubricated with magnetorheological fluid. The aim of the study was to determine the influence of selected factors on the axial force as a result of the oscillatory squeeze load.

**Słowa kluczowe:**

ciecz magnetoreologiczna, łożysko wzdluzne, badania, sciskanie oscylacyjne, sila normalna.

**Streszczenie**

Stan pracy wzdluznych łożysk ślizgowych jest funkcją wielu parametrów zarówno geometrycznych, jak i związanych z warunkami obciążenia węzła łożyskowego. Oprócz dotychczas stosowanych sposobów sterowania układami tego typu można wskazać na nowe możliwości modelowania ich charakterystyk pracy poprzez wykorzystanie jako środka smarnego substancji o sterowanych właściwościach reologicznych. Możliwość taką stwarzają ciecze magnetoreologiczne. Są to zawiesiny cząstek o właściwościach magnetycznych w cieczy nośnej (zazwyczaj w oleju mineralnym lub syntetycznym). Oddziaływanie polem magnetycznym na tego typu ciecze powoduje zmianę ich właściwości reologicznych. Proces ten jest niemal natychmiastowy i w pełni odwracalny.

W pracy przedstawiono wyniki badań wzdluznego łożyska smarowanego cieczą magnetoreologiczną. Celem badań było określenie wpływu wybranych czynników na wartość siły osiowej w łożysku w wyniku zadania obciążenia w postaci oscylacyjnego wymuszenia ściskającego.

## INTRODUCTION

Magnetic fluids are suspensions of ferromagnetic particles in a carrier liquid. Depending on the particle size, there is a distinction between magnetorheological (MR) fluid containing particles with an average

diameter of 1–20  $\mu\text{m}$  and ferrofluid (FF) composed of ferromagnetic nanoparticles with a size of 5–10 nm. The unique properties of magnetic fluids rely on the possibility of reversible, almost instantaneous, change in their rheological parameters, as well as changes in the flow direction due to the magnetic field. In mechanical

\* ORCID: 0000-0002-2258-4233. AGH University of Science and Technology, Faculty of Mechanical Engineering and Robotics, Mickiewicza Avenue 30, 30-059 Krakow, Poland, e-mail: horak@agh.edu.pl.

\*\* ORCID: 0000-0002-1997-357X. AGH University of Science and Technology, Faculty of Mechanical Engineering and Robotics, Mickiewicza Avenue 30, 30-059 Krakow, Poland, e-mail: e-mail: szczech@agh.edu.pl.

devices, magnetorheological fluids (MR) are used in vibration dampers, brakes and clutches [L. 1, 2], while ferrofluids (FF) are mainly used in seals [L. 3, 4]. Research has also been related to the development of sliding bearings with magnetic fluid as the lubricant [L. 5–7]. Such solutions may be characterized by simple constructions and the possibility of active control over working parameters. As a result, it is possible to achieve a higher reliability and stiffness of bearings than is the case with conventional solutions.

While considering the use of a magnetically active fluid as a lubricant, one should pay attention to the possibility of controlling the rheological parameters of the lubricant and the ability to hold it at a given position and to control the fluid flow by means of a magnetic field. In addition, in the magnetic fluid under the influence of a magnetic field, a pressure is created which can be used to separate the working surfaces of cooperating bearings [L. 7–10]. In the case of magnetic fluids which contain solid particles with ferromagnetic properties, this can significantly improve working conditions in the event of surface contact with mixed friction [L. 5, 12]. Another aspect of the use of magnetic fluids for slide bearings is the ability to limit the outflow of lubricant from the bearing working gap as a result of the self-sealing phenomenon. This effect is related to the possibility of maintaining the magnetic fluid in a specific position by means of magnetic field forces due to the appropriate shape of the bearing support surface, which results from the spatial magnetic field distribution. This limits the flow of lubricant from the lubrication gap, similarly to the case of seals with magnetic fluid [L. 13].

The paper presents the results of experimental investigations into the behaviour of selected MR fluid in an oscillatory compression condition. The analysis of

the influence of fluid properties, the height of the gap ( $h$ ), compression rate ( $\epsilon$ ), and the MR fluid volume ( $v$ ) on the compression force was carried out.

## TEST STAND AND TEST METHOD

The scheme of the test stand used in the tests is presented in Fig. 1a. A drive system and a test cell (4) were mounted on the frame. The drive system is a linear motor (1) that allows oscillatory motion in a vertical direction. A counterweight (5) was used to reduce the static load on the motor. The positioning accuracy of the linear motor is  $1 \mu\text{m}$ . A detailed description of the test stand is presented in [L. 14]. The test cell (Fig. 1b) consists of a body (7) inside which an electromagnet, consisting of windings (9), and a core (10), is placed. This unit is thermally stabilized by forced circulation of the cooling liquid. All tests were carried out at  $t = 20^\circ\text{C}$ . The MR fluid is placed in the gap (8) which is between the stationary plate (6) and the movable measuring plate (3), which carries out the oscillating motion in the axial direction. The measurement of axial force is performed using a force transducer (2), on which a moving plate (3) is mounted.

The research was carried out by using the geometry consisting of two parallel flat plates. The diameter of the upper plate was  $d = 45 \text{ mm}$ . A certain volume of the MR fluid was placed on the bottom plate, then, after the starting position ( $h_0$ ) was reached, the chamber was closed and measurements were made.

Four types of tests were carried out:

- 1) The examination of the influence of physical properties of MR fluid on the compression force value,

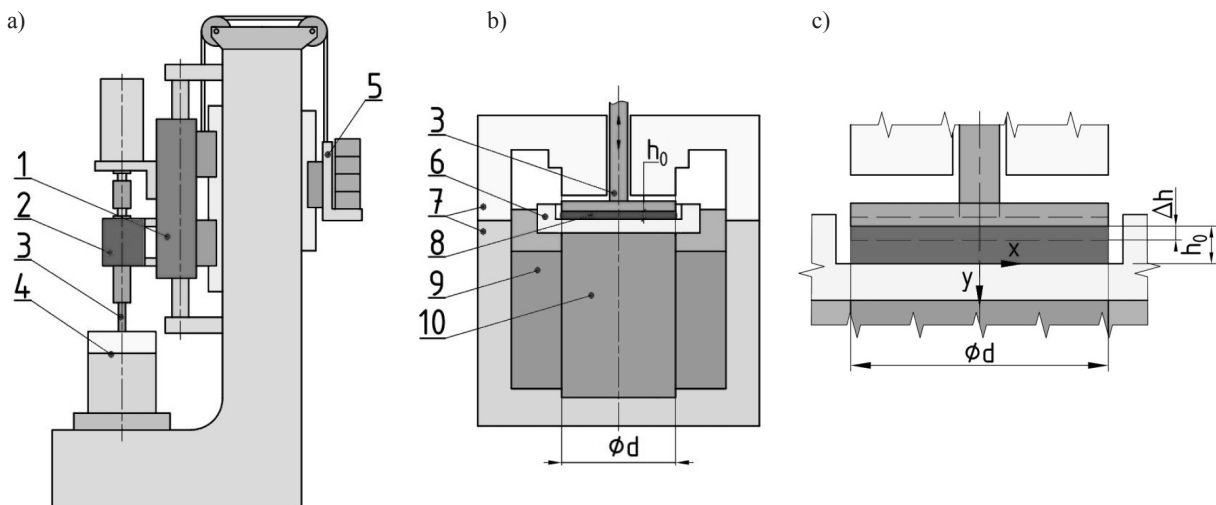

Fig. 1. Scheme of (a) the test stand, (b) the test cell, and (c) the test geometry

Rys. 1. Schemat: a) konstrukcji stanowiska, b) komory badawczej, c) geometrii badanej

- 2) The examination of the influence of the initial height of the working gap on the compression forces,
- 3) The examination of the influence of the MR fluid volume on the compression force value, and
- 4) The examination of the influence of oscillation frequencies on the compression force.

Studies (a), (b) and (c) were carried out for 14 measuring points, corresponding to different values

of the current supplying the electromagnet's winding:  $I = 0.00, 0.25, 0.5, 0.75, 1, 1.25, 1.5, 1.75, 2, 2.5, 3, 3.5, 4, \text{ and } 5 \text{ A}$ . The value of magnetic induction in the working gap space of the test cell, corresponding to the applied current range, varied in the range of  $B = 40 - 610 \text{ mT}$ . The characteristics of  $B = f(I)$  of the test chamber are shown in **Fig. 2a**.

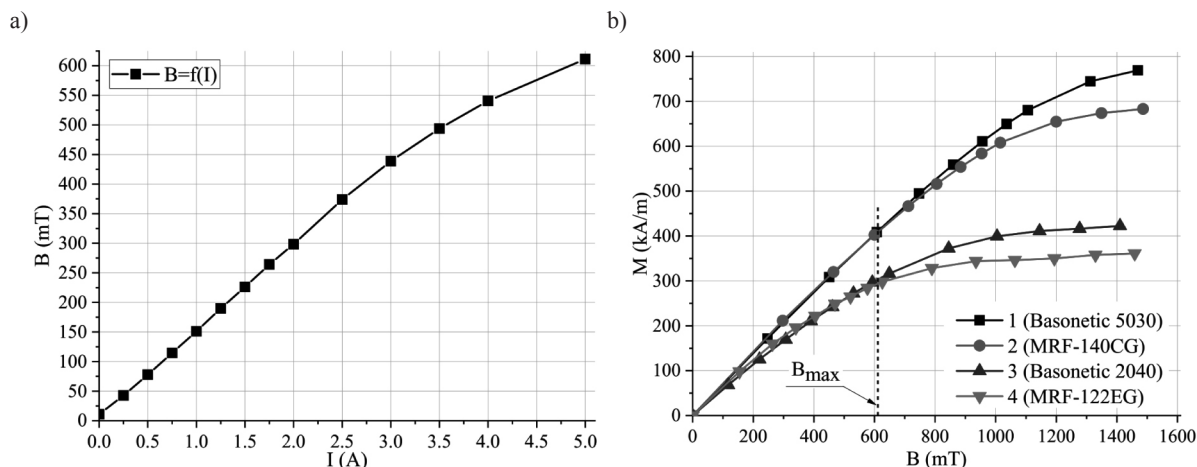

**Fig. 2. a) Characteristics  $B = f(I)$  of the test cell, b) magnetization curves of the tested MR fluids**  
 Rys. 2. a) Charakterystyka  $B = f(I)$  komory badawczej, b) krzywe magnetyzacji badanych cieczy MR

**Figure 3** presents an example of axial force change obtained on the basis of the test (initial gap height  $h_0 = 1 \text{ mm}$ , compression rate  $\epsilon = 0.2$ ). After establishing the starting position and setting the initial force to  $0 \text{ N}$ , the linear motor started to move in the oscillatory motion with the constant frequency ( $f$ ) and the range of movement ( $\Delta h$ ) – **Fig. 1c**. The axial force was measured while the current value changed. The aim of the tests was to analyse the values of the maximum compression force ( $F_{Nmax}$ ), measured for individual values of magnetic induction. In the work, the convention was adopted that the positive force is the force that causes the fluid to compress (reference system in accordance with **Fig. 1c**).

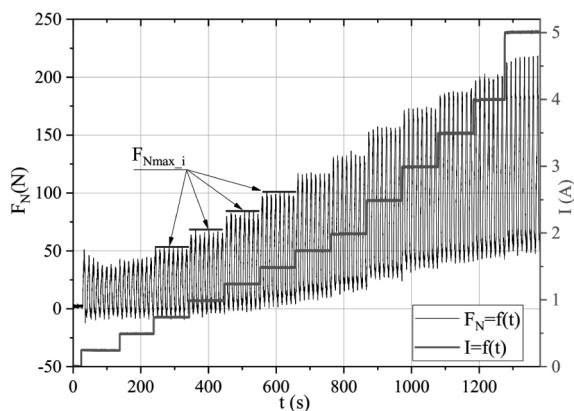

**Fig. 3. Sample measuring procedure (MRF-122EG,  $h_0 = 1 \text{ mm}$ ,  $\epsilon = 0.2$ )**  
 Rys. 3. Przykładowy przebieg pomiaru (MRF-122EG,  $h_0 = 1 \text{ mm}$ ,  $\epsilon = 0.2$ )

The tests were carried out on four commercially available MR fluids: Basonetic 5030 and Basonetic 2040 (manufactured by BASF [L. 16]), and MRF-122EG and MRF-140CG (manufactured by LORD Co. [L. 17]). Selected physical properties of the tested fluids are presented in **Table 1**. Dynamic viscosity was established for zero magnetic induction ( $B$ ) conditions at constant shear rate ( $\dot{\gamma}$ ) and constant temperature ( $t$ ).

The order of the positions in **Table 1** depends on the value of fluid saturation magnetization. Fluid 1 is characterized by more than twice the saturation magnetization value than Fluid 4. Differences in the density of the tested fluids indicate a difference in the content of ferromagnetic particles in the tested MR fluids.

**Table 1. Physical properties of the examined MR fluids**  
 Table 1. Właściwości fizyczne badanych cieczy MR

No.	Name	Density	Dynamic viscosity ( $B = 0 \text{ T}$ , $\dot{\gamma} = 100 \text{ s}^{-1}$ , $t = 25^\circ\text{C}$ )	Saturation magnetization
		$\text{kg/m}^3$	$\text{mPa}\cdot\text{s}$	$\text{kA/m}$
1	Basonetic 5030	4120	582.9	791
2	MRF-140CG	3540	1569.1	698
3	Basonetic 2040	2470	1075.7	424
4	MRF-122EG	2380	203.4	361

In **Fig. 2b**, the magnetization curves of the tested fluids are presented. It can be noticed that, in the analysed range of the current supplying the electromagnet, saturation magnetization of the tested fluids was not obtained. In addition, in the analysed range of magnetic induction ( $B_{max} = 610$  mT), the magnetization curves (**Fig. 2b**) of Fluids (1) and (2) and (3) and (4) coincide with each other, and up to  $B < 200$  mT characteristics are very similar to each other. A detailed discussion of the rheological properties of the investigated fluids is presented in [L. 15].

## TEST RESULTS

The aim of the first research stage was to investigate the response of selected MR fluids during oscillatory compression. The following extortion parameters were adopted:  $h_0 = 0.5$  mm,  $\Delta h = 0.1$  mm,  $f = 0.1$  Hz, and  $B = \text{var}$ . The volume of the tested liquid  $v = 0.8$  ml. Due to the measuring range of the force transducer, the test was stopped if the force  $F_{Nmax}$  exceeded 200 N. The results of measuring the maximum compression force of the tested fluids are presented in **Fig. 4**.

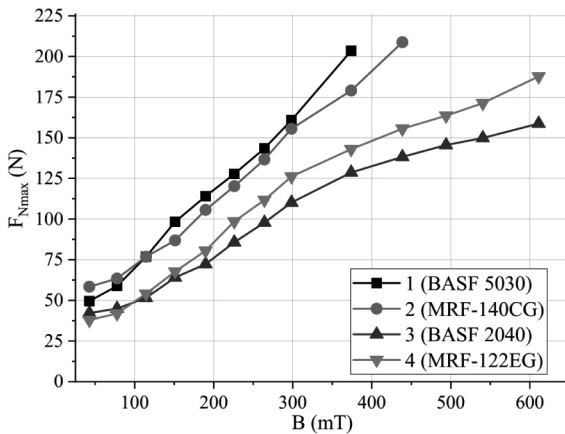
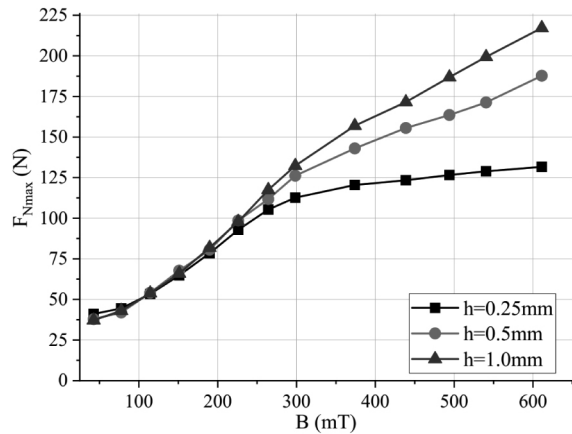

**Fig. 4.**  $F_{Nmax} = f(B)$  for examined MR fluids  
Rys. 4.  $F_{Nmax} = f(B)$  dla badanych cieczy MR

For all the tested fluids, it is possible to indicate the similarity of the trend of measured forces with magnetization curves (**Fig. 2b**). Higher  $F_{Nmax}$  values are observed for fluids that have a higher saturation magnetization value. For Fluids (1) and (2), the trend of  $F_{Nmax}$  variation is close to linear. For Fluids (3) and (4) the curves also have a similar course. For fluids with the highest magnetization, (1) and (2), due to the large values of the force, the measurement was interrupted before reaching the maximum value of magnetic induction. At the same time, higher values of force are observed for the fluids with a lower zero viscosity, (4), although it has the lowest value of saturation magnetization.

In the second stage of the research, the impact of the initial height of the working gap on the obtained values of axial force was analysed. The results of the measurements

are shown in **Fig. 5**. Fluid (4) was tested for three heights of the initial gap  $h_0 = 0.25, 0.5,$  and  $1$  mm, and, in each of the analysed cases, the compression rate was analogous and amounted to  $\varepsilon = 0.2$ , which corresponds to  $\Delta h = 0.05, 0.1,$  and  $0.2$  mm. Respectively to the gap height  $h_0$ , the MR fluid volume in each case corresponds to the degree of filling  $v = 100\%$  ( $v = 0.4, 0.8,$  and  $1.6$  ml).

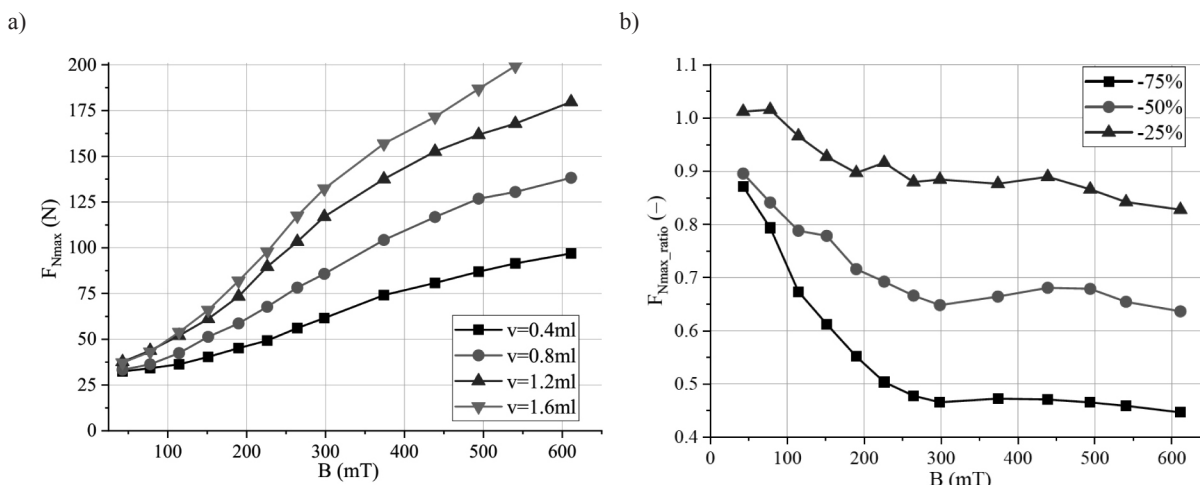

**Fig. 5.**  $F_{Nmax} = f(B)$  for various initial gap height ( $h_0$ )  
Rys. 5.  $F_{Nmax} = f(B)$  dla różnych wysokości początkowych szczeliny roboczej ( $h_0$ )

At lower values of magnetic induction, the initial gap height value does not have a significant impact on the range of obtained force. The impact of this parameter is noticeable for  $B > 225$  mT and, in this case, by increasing the initial height, this results in an increase in the axial force. In the extreme case, the difference was 86 N, which is a difference of nearly 63%. In addition, at the lowest value of  $h_0$ , the  $F_{Nmax}$  increase is the smallest when increasing  $B > 300$  mT.

The third type of test was to analyse the influence of the MR fluid volume applied to the gap on the maximum compression force. The test results are presented in **Fig. 6**. The tests were carried out for the case  $h_0 = 1$  mm,  $\Delta h = 0.2$  mm (compression rate  $\varepsilon = 0.2$ ), the volume of the tested fluid, (4), applied to the working space of the station was  $v = 0.4, 0.8, 1.2,$  and  $1.6$  ml, which corresponds to the fill level  $v = 25, 50, 75,$  and  $100\%$ .

Reducing the fill level in the gap results in a decrease of the observed force value, and the difference between the curves are larger for higher magnetic induction. In the case of the lowest values of magnetic induction ( $B < 100$  mT), the differences are below 20% (calculated in relation to the degree of filling  $v = 100\%$ ). At  $B > 300$  mT, a 25% MR fluid insufficiency reduces the force by about 10%, and 50% MR fluid insufficiency reduces it by about 50%. A reduction in  $v$  from 100% to 25% results in more than double the decrease in axial force (from 200 to 91.5 N). It should be noted that, for  $B > 300$  mT, although significant differences in the maximum force values are observed, the relative differences between the forces are approximately constant. This may be due to the position change of the MR fluid in the working gap of the measurement system.



**Fig. 6. a)  $F_{Nmax} = f(B)$  for various sample volumes (v), b) ratios of measured forces**  
 Rys. 6. a)  $F_{Nmax} = f(B)$  dla różnych objętości cieczy (v), b) proporcje mierzonych sił

The last stage of the tests was concerned with determining the influence of oscillation frequency on the axial force change. The tests were carried out for two values of magnetic induction  $B = 150$ , and  $300$  mT, and three oscillation frequencies  $f = 0.2, 0.4$ , and  $0.8$  Hz. The MRF-122EG fluid, (4), was tested. The results are presented in Fig. 7.

In the analysed range, no significant influence of oscillation frequencies on the force variation in the compression and stretching phase is observed. Similarly, there are no significant differences for the maximum forces in the extreme positions of the movable plate ( $\Delta h = 0$  and  $\Delta h = 0.1$  mm). With increasing magnetic induction, the hysteresis loops are shifted towards higher values of force. Moreover, higher  $F_N$  values are observed at the initial position of the moving plate. This is related to magnetostatic pressure, with a detailed analysis of this issue being presented in the papers [L. 4, 10].

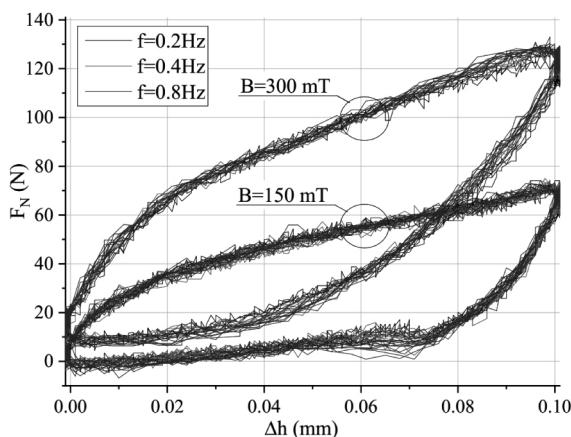

**Fig. 7.  $F_N = f(\Delta h)$  for  $B = \text{var.}$  and  $f = \text{var.}$**   
 Rys. 7.  $F_N = f(\Delta h)$  dla  $B = \text{var.}$  i  $f = \text{var.}$

**CONCLUSION**

Research has shown that it is possible to obtain considerable forces when the MR fluid is subjected to extortion of the oscillating compression. The obtained forces at the level of  $200$  N indicate that the pressure in the working gap exceeded  $125$  kPa. As expected, along with the increase in magnetization of the MR fluid, the compression force increases; however, it should be remembered that the resistance of the system movement also increases. In the case of a thrust bearing, this will be associated with an increase in the frictional torque. This issue was analysed in detail in [L. 15].

At low values of magnetic induction, the initial gap height does not have a significant effect on the compression force values. This behaviour may be related to the rheology of MR fluids and, by increasing  $h_0$ , the shear rate of the fluid in the working gap also decreases. At the same time, increasing the magnetic induction increases the tangential stress in the fluid. A full explanation of this phenomenon requires more detailed research.

Reducing the MR fluid volume in the working gap by up to  $25\%$  causes a relatively small decrease in the compression force. From the point of view of thrust bearings, this is a favourable phenomenon, indicating that the system can be maintained even if a certain loss of MR fluid occurs. This is probably connected with the distribution of the MR fluid inside the gap. For a given excitation range, no significant influence of the oscillation frequency on the value of axial force was observed.

**ACKNOWLEDGEMENTS**

This work is supported by AGH University of Science and Technology under research programs No. 16.16.130.942.

## REFERENCES

1. Raj K., Moskowitz B., Casciari R.: Advances in ferrofluid technology, *Journal of Magnetism and Magnetic Materials*, 1995, 149.
2. Chengye L., Fengyan Y., Kejun J.: Design and finite element analysis of magnetic circuit for disk MRF brake. *Advanced Materials Research*, 2011, 181-182:22–527.
3. Vekas L.: Ferrofluids and Magnetorheological Fluids, *Advances in Science and Technology*, vol. 54 (2008), 127.
4. Szczęch M., Horak W.: Numerical simulation and experimental validation of the critical pressure value in ferromagnetic fluid seals, *IEEE Transactions on Magnetics*, 2017, vol. 53(7) art.no. 4600605.
5. Mischczak A.: Analysis of hydrodynamic lubrication of journal bearings, Gdynia, Foundation for the Development of the Gdynia Maritime University, 2006.
6. Kuzhir P.: Free boundary of lubricant film in ferrofluid journal bearings, *Tribology International*, 4, 2008, 41.
7. Guldbakke J. M., Hesselbach J.: Development of bearings and a damper based on magnetically controllable fluids, *Journal of Physics*, 2006, 2959.
8. López-López M.T, Kuzhir P., et al.: Normal stresses in a shear flow of magnetorheological suspensions: viscoelastic versus Maxwell stresses, *Journal of Rheology*, 2011, 54.
9. Laun H.M., Gabriel C., et al.: Primary and secondary normal stress differences of a magnetorheological fluid (MRF) up to magnetic flux densities of 1 T, *Journal of Non-Newtonian Fluid Mechanics*, 2008, 148.
10. Salwiński J., Horak W.: Measurement of normal force in magnetorheological and ferrofluid lubricated bearings, *Key Engineering, Materials*, 2012, 25.
11. Burcan J., Jozefowicz L., et al.: Wpływ cieczy magnetycznie aktywnej na warunki pracy węzła z tarciami wiertnym. *Problemy niekonwencjonalnych układów łożyskowania*, Łódź 1999.
12. Nagayaa K., Takedaa, S., et al.: Thrust bearing using a magnetic fluid lubricant under magnetic fields, *Tribology International* 1, 1993, 26.
13. Horak W., Salwiński J., Szczęch M.: Test stand for the examination of magnetic fluids in shear and squeeze flow mode, *Tribologia*, 2, 2017, pp. 67–76.
14. Horak W., Salwiński J., Szczęch M.: Experimental Study on Normal Force in MR Fluids Under Low and High Shear Rates, *Machine Dynamics Research*, 2017, vol. 41, no. 1, pp. 89–100.
15. Horak W., Salwiński J., Szczęch M.: The influence of selected factors on axial force and friction torque in a thrust bearing lubricated with magnetorheological fluid, *Tribologia*, 4, 2017, pp. 33–38.
16. BASF The Chemical Company, <http://www.basonetic.com>.
17. LORD Corporation, <http://www.lord.com>.