

Jacek WOJUTYŃSKI, Mariusz SICZEK

Institute for Sustainable Technologies – National Research Institute, Radom
jacek.wojutynski@itee.radom.pl; mariusz.siczek@itee.radom.pl

ENGINEERING TEACHING SYSTEM LABORATORY FOR MECHATRONIC EDUCATION

Key words

PLC, HMI, engineering teaching stand, e-learning.

Abstract

This article presents the concept of mechatronic laboratories' construction of an engineering teaching stand for PLC driver programming and HMI operator panel. It discusses the capabilities of the stands from the point of view of technical and software solutions, and the engineering teaching stands are described for e-learning in programming mechatronic devices. The engineering teaching stand stands were created within the framework of research tasks: "Modular apparatus for innovative training methods in the area of advanced technology for sustainable development" of the Strategic Programme Innovative Economy Policy "Innovative technical support systems for sustainable development economy."

Introduction

The engineering teaching stands for mechatronic education are designed for learning PLC drivers and touch screen HMI panels tied to a real-life model of the process. The developed concept of teaching stands include the following:

1) installing user control and safety control to prevent damage to the control object, 2) galvanic separation of user control and safety control, 3) remote access to the control and operator panel, and 4) remote viewing of engineering teaching stand with CCD cameras. Professional training retirements were included to comply with the documents of Ministry of Education and National Centre for Supporting Vocational and Continuing Education. The following were assumed for design:

- The control object will be real, used in industrial practice, for example, a slat conveyor used in the pharmaceutical or cosmetic industry.
- Modern sensors will be used that are rarely employed in industrial practice such as programmable ultrasonic liquid level sensor, vibrating liquid level indicator, and programmable colour sensor.
- As actuators the following are applied: valve units for servomotors, servo- step motors with an encoder and a controller with linear modules, vacuum pumps, peristaltic pumps, etc.
- The positioning will be equipped with one-or three-phase meter for mains network parameters, 1 allowing the monitoring of the consumption of electricity. The aim is to increase awareness and teach the need to monitor the energy consumption of machines. Energy consumption is also an important parameter that can be used for diagnostics.
- Each stand will be autonomous in terms of the media needed for control, and depending on the needs, there will be a muted compressor or hydraulic power unit or water tank (closed-loop). The stand will be connected to electricity only.
- Standard signals used in industrial automation will be use, that is for digital signals – voltage signal 0-24VDC PNP or NPN2 for analogue signals 4–20 mA/0-10VDC. This standardization will allow other companies to use the PLC controller.

As part of the development of the stands, the structure is provided for the possibility of adding or replacing other sensors and actuators by leaving several PLC inputs/outputs free.

1. The design of the engineering teaching stands

The design of the engineering teaching stands has been developed in the ITeE – PIB since 2011, when the model stand was developed for the programming of measuring and control systems within a virtual laboratory convention, and it has gone through the successive stages of the mechatronic design improvement, which included the following:

- The concept of the engineering teaching stand's appearance – construction of the frame on which the controller is placed, operator panel and physical model of the controlled process;

- Selection of physical models – examples of processes that will be controlled, that will fit on the frame and that will be visible for the CCD camera. The following stands were selected for development: for technological conveyor line, for liquid level adjustment, pressure (including negative pressure), and for linear module control using the servo step drive;
- Separating the user controller from the security controller: galvanic separation was developed between the analogue and digital signals the security control, the security controls, and the physical model;
- The selection of remote access to the system; and,
- The selection of the controller and operator panel.

All of these steps in the improvement of the construction were carried out in parallel, with the last two being the key stages.

The criterion for the PLC controller selection is the ability to use the latest information technology without the need for additional modules. The selected controller Micro Smart Pentra, type FC5A-D12S1E by Idec (CPU, 8 digital inputs, 4 digital transistor outputs), is equipped with a built-in webserver. Thus, it allows one to work on an Ethernet network, save one's own web pages on the controller, assign the IP address, use Modbus TCP Client/Server protocol, send emails, and remotely edit and upload the controller programme. Communication with the operator HMI panel is also on an Ethernet network. It is a modern solution that is easily learned by college and technical school students who are familiar with new information technologies. Each teaching stand is equipped with an additional, RS485, communication module intended for Modbus RTU/ASCII Master/Slave networks. It is used for in combination with a meter for single-phase network parameters. The controller has a software tool for easy use of Modbus RTU/ASCII protocol and listed on-line features. Moreover, the PLC controller has built-in double-precision arithmetics, 3 a floating point, mathematical functions, and a large list of extended instructions.

For remote communication the test stand uses a SiteManager module and hardware server GateManager by Secomea, which does not require a fixed IP and VPN address and has encrypted transfer and provides the encryption of data and user permissions management. GateManager is an Internet server operating in the cloud technology. The system can provide remote communication with such devices as PLC, HMI, PC, by any producer, with one of the following interfaces: Ethernet, RS232 serial port, or USB port. The API server provides remote access for students and teachers to the engineering teaching stands with the actual physical models of industrial processes.

Access to the stands and the learning process are supported by dedicated LCMS software (Learning Content Management System), which provides an educational platform oriented towards educational process management, including education content, access queuing, and monitoring student progress.

Figure 1 shows the concept of engineering teaching stands. The physical model is controlled by the PLC user controller and by the HMI operator panel. A physical model is observed with one or more CCD cameras. The PLC security controller prevents the generation of incorrect states on the user PLC controller for the physical object. If, for example, the PLC security controller detects a dangerous status, it blocks the possibility of using the heater when temperature has been exceeded.

The applied security facilitates training using e-learning methods. Access to the stand takes place through the SiteManager module, and management of all the stands is done by the GateManager server and Moodle software that provides the appropriate teaching aids registers, registers the software states introduced to the PLC controller, stores CCD camera recordings, and supports the assessment of the implementation of the exercise.

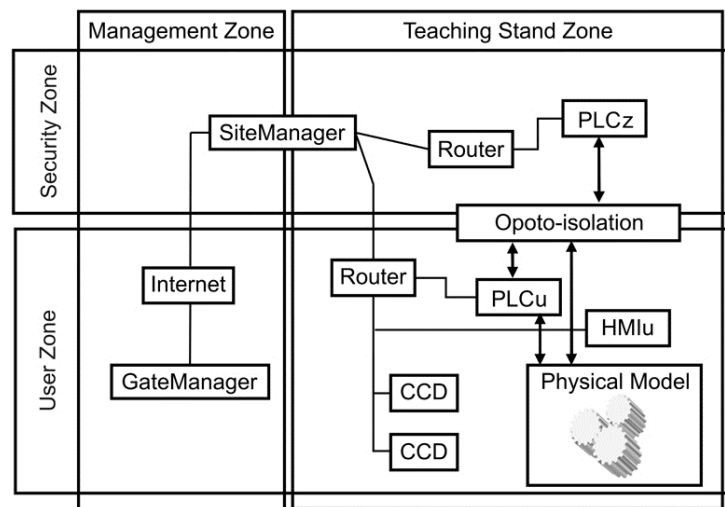

Fig. 1. The concept of stands for e-learning of PLC programming and HMI operator panel

For the stand construction, a modern touch-screen, colour operator panel was selected with a resolution of 460×480 pixels and 5.7" screen, with a built-in Webserver, SD card reader and two USB ports. The panel can store data and procedures on the SD card. The panel has a built-in webserver. Software tools of the operator panel are mini-SCADA software, i.e. it allows the supervision of the technological process or production. Its main functions include the collection of actual data (measurements), visualization, process control, alarm functions, and data archiving.

Farther on, this article presents engineering teaching stands for e-learning of PLC controller programming, for which patent applications have been developed.

2. Implementation of a stand for e-learning in conveyor engineering

The diagram (Fig. 2) shows the main elements of the physical model of the teaching stand for PLC controller and HMI operator touch screen for conveyor engineering.

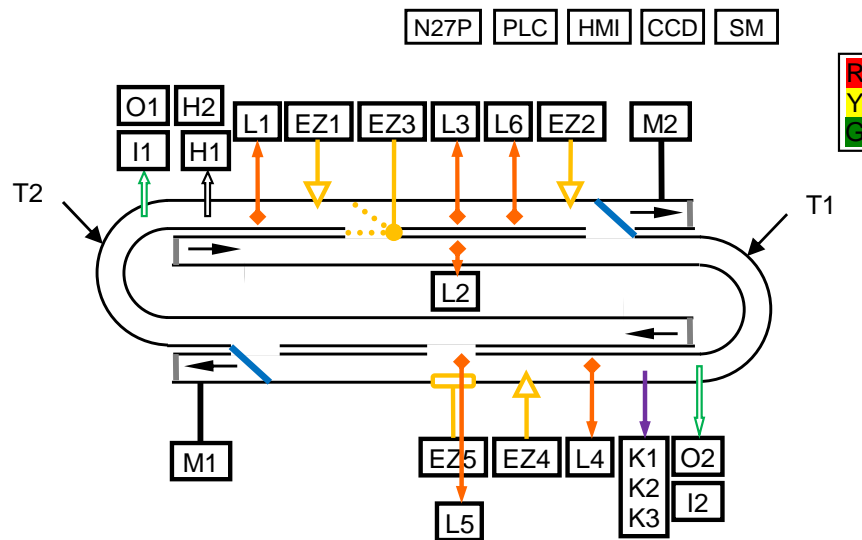

Fig. 2. A diagram for a mobile teaching stand diagram for e-learning of the PLC programming in the field of conveyor engineering

Two slat conveyors, T1 and T2, type X45 work in the 2U configuration (Fig. 2), and cylindrical elements in different colours made of metal and Tarnamid are placed on small pallets of the conveyor. The switches highlighted in blue prevent the small pallets at the end of the conveyor from falling off by redirecting them automatically to another conveyor. The switches direct movement in a closed system. The DC, M1, and M2, motors drive the conveyors. The direction of movement of the conveyors is marked by arrows. It is not possible to change the direction or the speed of the movement of the conveyors.

Electric valves EZ1–EZ5, of 5/2 type mounted on the valve unit control unilateral mini-cylinders. The operation of the actuators is described by the following electric valves:

- EZ1 EZ2 – pause the movement of the small pallets small pallets for conveyor T2;
- Ez4 – pauses the movement of small pallets for conveyor T1;

- Ez3 – redirects the small pallets from T2 to T1 conveyor or leaves them on the T2 conveyor; and,
- EZ5 – moves the small pallets from the T1 to T2 conveyor.

Laser sensors L1, L3, and L6 detect the position of the small pallets on the T2 conveyor. Laser sensors L2, L4, and L5 detect the position of the small pallets on the T1 conveyor. The H2 and H1 fork sensors are used to determine the height of the items placed on the small pallets. Inductive I1 and I2 sensors, and O1 and O2 reflective sensors, are connected and grouped as shown in Fig. 2. The colour sensor with K1, K2, and K3 outputs respond to “remembered” colours of the small pallets.

The PLC controller, HMI touch screen operator panel, and the CCD camera all have their IP addresses and work on the Ethernet network. Remote access is possible through the SM module – SiteManager1149. Electricity consumption meter N27P works in the Modbus RTU network.

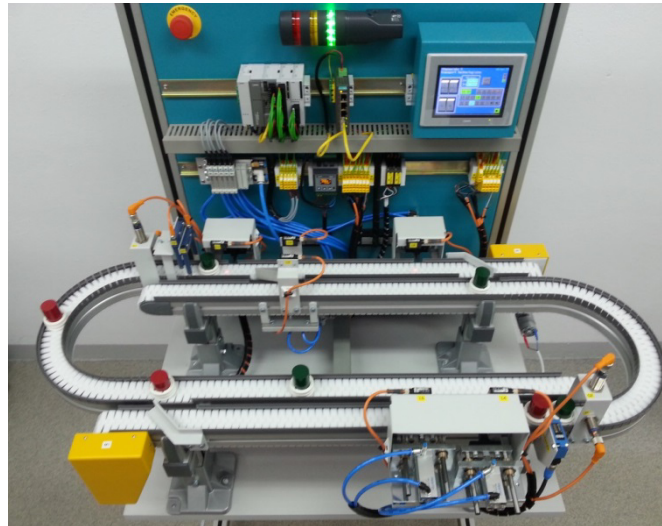

Fig. 3. The physical model of mobile teaching stand for e-learning of PLC programming for conveyor engineering

Figure 3 shows the complete model for mobile teaching stand for e-learning of PLC programming for conveyor engineering.

3. Implementation of a stand for conveyor engineering e-learning

The diagram (Fig. 4) shows the main elements of the physical model of a teaching stand for PLC controller programming and the HMI operator touch screen panel for regulating liquid levels.

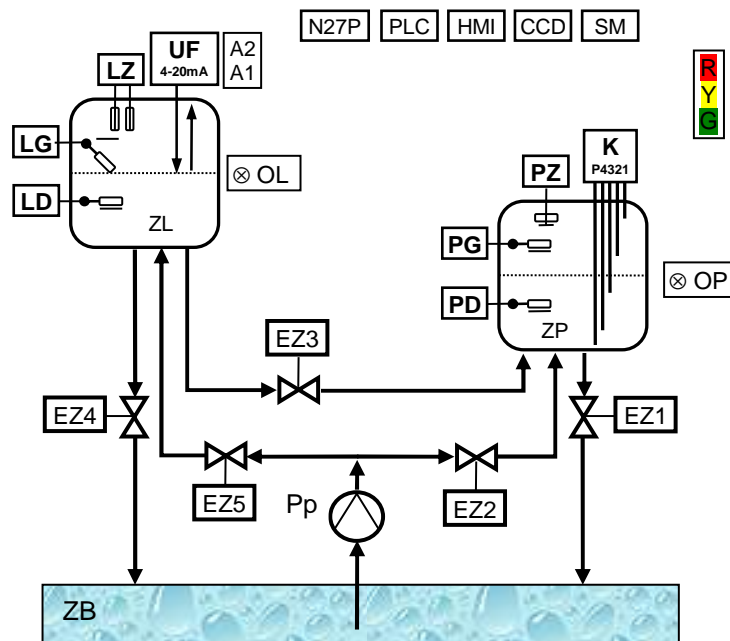

Fig. 4. A diagram for a mobile teaching stand for e-learning of PLC programming for liquid level control

Two tanks, left – ZL and right – ZP, are filled by a peristaltic pump Pp and a set of valves: EZ2, EZ3, and EZ5. The EZ1 and EZ4 valves are used for emptying the tanks. The left tank is placed higher in relation to the right tank, which allows gravitational flow of the liquid. The following were applied to control liquid levels:

- Float sensors with contactronic contact - PZ, PG, PD, LG, and LD;
- Vibrating signal for liquid level – LZ;
- Ultrasonic, programmable liquid level signal, with an analogue output – UF; and,
- Liquid level monitor with conductometric probe – K.

The PLC controller, HMI touch screen operator panel, and CCD camera all have their IP addresses, and work on the Ethernet network. Remote access is possible through the SM module – SiteManager1149. Electricity consumption meter N27P works in the Modbus RTU network.

Led illuminators OL and OP are used to improve the visibility of the liquid level in the tanks. The ZB tank has its own peristaltic pump, and an UV lamp to prevent the formation of algae.

The A1/A2 (ON)-OFF-(ON) switch is used for ultrasonic liquid level indicator programming.



Fig. 5. A physical model of a mobile teaching stand for PLC programming e-learning in terms of liquid level control

Figure 5 shows a complete model of a mobile teaching stand for e-learning PLC programming for the regulation of liquid levels.

4. Implementation of an e-learning stand for pressure regulation

The diagram (Fig. 6) shows the main elements of the physical model of teaching stands for PLC programming and HMI operator touchscreen panel for pressure regulation.

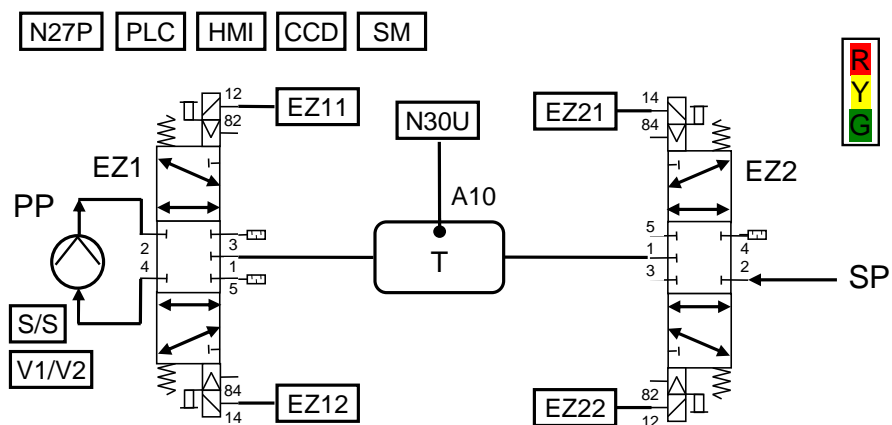

Fig. 6. A diagram of a mobile teaching stand for e-learning PLC programming for pressure regulation

The Pp pump is performance-adjustable and always operates in one direction. Electric valve EZ1 type 5/3 depending on the controller produces positive or negative pressure in the tank T. The EZ2 electric valve type 5/3, depending on the control, produces positive pressure in the tank T for a compressor SP or it drains tank T. To monitor pressure, a pressure sensor A10 was used in conjunction with indicator type N30U.

The PLC controller, HMI touch screen operator panel, and CCD camera all have their IP addresses, and work on the Ethernet network. Remote access is possible through the SM module – SiteManager1149. Electricity consumption N27P meter and N30U pressure gauge work in Modbus RTU network.



Fig. 7. Physical model of a mobile teaching stand for e-learning of PLC programming in pressure regulation

Figure 7 shows the completed model of mobile teaching stand for e-learning of PLC programming in pressure regulation.

5. Teaching package for e-learning stands

The teaching package is understood as “all teaching resources and materials involved in the process of teaching-learning which form the elements of structure of the subject content that is governed by the objectives, content, methods and form of organization, methodology ranking, which – by having specific teaching functions – help students learn and understand material and its

interrelationships, and the skills and habits in a way that is active, realistic, aware, partly or completely autonomous, creative, and lasting”.

The engineering teaching stand includes the following:

- Schematic diagram (Fig. 2) with the PLC addresses related to sensors and actuators supplied;
- Wiring diagram;
- The files of catalogue cards of items used in the construction of the engineering teaching stand;
- A sample PLC program with a description and screenshots;
- A sample HMI operator panel program with descriptions and screenshots; and,
- Interactive instructions *.html associated with directory cards of the elements used in the construction of the engineering teaching stand.

The delivery of the engineering teaching stands includes a presentation about the PLC programming and HMI operator panel. The basic presentation on the use and programming of the PLC includes the following:

- Technical specifications the CPU type FC5-D12S1E;
- Expansion modules for digital and analogue input/output;
- Communication modules;
- Connecting modules;
- The use of PNP and NPN sensors connected to one input module;
- The PLC configuration;
- PLC controller networking;
- List of allocation lists) - registers, flags, counters, timers;
- Special features: quick counters, PWM, frequency measurement; failures, potentiometer input;
- Data types, which are the consequences of an incorrect data type declaration;
- Software tools for PLC controller;
- Basic instructions;
- Extended instructions, including arithmetic instructions;
- The macro instructions; and,
- Modbus RTU and Modbus TCP protocol.

The presentation on HMI operator panel programming includes the following:

- HMI operator panel configuration;
- HMI operator panel networking;
- HMI operator panel software tools;
- Allocation list for operator panel – registers and flags;
- HMI operator panel as SCADA;
- Main screen elements;
- Text and tag manager and language versions; and,
- Script type instructions.

The presentation also covers the following specific issues related to the included examples of programs for PLC controller and HMI operator panel:

- The principles of systematic programming;
- Defining Modbus RTU Master protocol in conjunction with the parameters measurements of the power supply, and programming the supply parameter meter;
- Rounding and conversion, with their implementation on the HMI panel;
- Screen saving using the PLC or HMI programme;
- The macroinstructions - ANST and RAMPST;
- Special register of the D8058 in the PLC;
- Application of conditionals in the HMI objects based the example of press-button lock (Where is the program in HMI or PLC?);
- A dynamic bar graph as an example script in the HMI (Where is the program in HMI or PLC?);
- Special M8003 and M8004 flag, special D8006 and D8005 registers in the PLC; and,
- Programming of the counters, INC and DEC instructions, and implementation of the asynchronous mechanism.

The teaching package for the teaching stands and the teaching stands themselves constitute a comprehensive offer of the Institute's in the field of teaching methods and tools and the development of innovative forms of improving staff qualifications.

Implementations

The developed models of an engineering teaching laboratory has been implemented in several leading academic centres and vocational schools.

The engineering teaching stands for e-learning of the programming of the the PLC controller and HMI operator touch-screen panel has been presented at national and international conferences on numerous occasions.

An Internet website, The Laboratory of Engineering Teaching Systems for Mechatronic Education at l-stem.eu has been launched to promote the designed stands.

Summary

In the EU countries, there is a deficit of workers in the field of engineering. In Poland, there is an urgent need for rebuilding vocational education. Therefore, training in the field of STEM subjects (Science, Technology, Engineering, and Mathematics) fits perfectly in a competitive economy trends. The developed stands are proposed to meet the needs of the labour market. The engineering teaching stands in the presented form are intended for secondary schools, colleges, and continuing education.

The developed engineering teaching stands give access to educational equipment and laboratories, remote e-learning courses, allow educational schools, universities, and training companies a broadening of their educational offer.

References

1. Dąbrowski M.: E-learning w szkolnictwie wyższym. *Studia BAS* 3(35), 2013, pp. 203–212.
2. Kowalik D., Wojutyński J., Siczek M.: E-learningowe stanowiska dydaktyczne w nowoczesnym kształceniu zawodowym. *Międzynarodowa Konferencja Naukowa – Rozwój zawodowy nauczycieli*, 20–21 listopada 2014, Jedlnia-Letnisko. *Edukacja Ustawiczna Dorosłych*, 4/2014, p. 199.
3. Podstawa programowa kształcenia w zawodach. Rozporządzenie Ministra Edukacji Narodowej z dnia 7 lutego 2012 roku w sprawie podstawy programowej kształcenia w zawodach (Dziennik Ustaw z 2012 r. poz. 184). MEN, Warszawa 2012.
4. Rekomendowane wyposażenie pracowni i warsztatów szkolnych dla zawodu technik mechatronik opracowane na potrzeby Regionalnych Programów Operacyjnych na lata 2014–2020. http://wyposazenie.koweziu.edu.pl/technik_mechatronik.docx, Access 19.06.2015.
5. Siczek M., Wojutyński J.: Mobilne stanowisko dydaktyczne zwłaszcza do e-learningu programowania sterowników PLC w zakresie regulacji poziomu cieczy. Patent pending no. P. 408151.
6. Siczek M., Wojutyński J.: Mobilne stanowisko dydaktyczne zwłaszcza do e-learningu programowania sterowników PLC w zakresie transportu technologicznego. Patent pending no. P. 408152.
7. Siczek M., Wojutyński J.: Mobilne stanowisko dydaktyczne zwłaszcza do e-learningu programowania sterowników PLC w zakresie regulacji ciśnienia. Patent pending no. P. 4081501.
8. Wojutyński J., Siczek M.: Wirtualne laboratorium do nauki zdalnej programowania sterowników PLC oraz pulpitów HMI. *Edukacja Ustawiczna Dorosłych*, 2/2015, s. 148–156.
9. <https://womgorz.edu.pl> , accessed 03.11.2015.

Laboratorium systemów technodydaktycznych do edukacji mechatronicznej**Słowa kluczowe**

PLC, HMI, stanowiska technodydaktyczne, e-learning.

Streszczenie

W artykule przedstawiono koncepcję budowy laboratoriów mechatronicznych stanowisk technodydaktycznych w zakresie nauki programowania sterownika PLC i pulpitu operatora HMI. Omówiono możliwości stanowisk od strony rozwiązań technicznych oraz programowych. Omówiono stanowiska technodydaktyczne do e-learningu w zakresie oprogramowywania urządzeń mechatronicznych. Stanowiska technodydaktyczne powstały w ramach zadania badawczego pt.: „Modułowa aparatura badawcza dla innowacyjnych metod kształcenia w obszarze zaawansowanych technologii zrównoważonego rozwoju” Programu Strategicznego POIG „Innowacyjne systemy wspomagania technicznego zrównoważonego rozwoju gospodarki”.