

OPTIMAL PROJECT PARAMETERS OF THE BRIDGE CRANES MAIN BEAMS

Georgiy Vishnevetsky, Valentin Kovalenko, Sergii Sydorenko

*National Technical University "Kharkov Polytechnic Institute"
Engineering faculty, Cathedra "Handling machinery"
Frunze Street 21, Kharkov 61002, Ukraine
tel.: +38(057)707-65-24, +38(057)706-27-49
e-mail: gorge40@mail.ru, potap@mipk.kharkiv.edu, sergfm@list.ru*

Damian Brewczyński

*Cracow University of Technology
Faculty of Mechanical Engineering
Institute of Machine Design
Jana Pawła II Av. 37,31-864 Krakow, Poland
tel.: +48 12 6283408, fax: +48 12 3743360
e-mail: brewczyn@mech.pk.edu.pl*

Abstract

In the article are presented main principles and leads-up to the choice of the general criterion of the main beams' optimization. The main reasons leading to the destruction of arms include cyclic load causing fatigue phenomena, creep occurrence causing elements deformation beyond a critical state, the constructions' blistering appearing owing to the metal maturing, corrosion of the main beams' elements, leading to the loss of their carrying capacity. The general optimization criterion is chosen. The parameters of the main beams' endurance are defined. The device for the measuring of the size and the character of the vibrations' decay of the bridge cranes' main beams is suggested. We have the results of the experimental information, received on the bridge cranes of the different plants. The work directions by the optimization of the constructive parameters of the cranes' main beams are defined. Into the suggested construction of the span beam are put such statements: high values of the general optimization criterion's; stiffness of the arm to the reduced weight ratio, possibility of the beam's creation of the equal resistance, minimization of the local deflection tensions from the load cart on account of the inclined walls' position. The construction of the patented span beam of the diaphragm construction is observed and described.

Keywords: *machine building, bridge cranes, span beams, geometrical section parameters, optimal beam constructions, time of the free vibrations' decay*

1. Introduction

Traditional way of the span beams of the bridge cranes supposes the optimization of the geometric parameters of the beam section, for which the choice criterion looks so

$$F_{\text{sech}} \rightarrow \min \quad (1)$$

with the limits by the durability criterion, the diapason of the belts' and vertical walls' thickness, also beams' width and height, with the providing of the regulated beams' deflection and free vibrations' decay time.

The decision of the real-optimal project parameters' realization problem is enough actual and called-up. First of all, there is a question about the choice of the optimal criteria.

Considering the character of the cranes' work as general optimization criterion can be accepted

the size of the specific reduced expenses on 1 ton of the transported load. In our case, it is the difference of the reduced expenses between basic and projected crane variants with the identical passport characteristics.

The difference of the reduced responses ΔP as the objective looks so

$$\Delta P = \frac{1}{A} \left(\frac{1}{T_{OK}} \cdot \Delta m \cdot k_{ch} + C_B - C_{PR} \right) \rightarrow \max, \quad (2)$$

where:

A – annual load stream, t/year,

T_{OK} – term of the payback main materials (it is possible to consider payback term T_{OK} equal to the normative exploitation term T_N), years,

Δm – mass difference of both main beams in base and projected variants, t,

k_{ch} – world construction price, classified to the mass of this construction, c.u. (conventional units),

C_B, C_{PR} – annual exploitation expenses by basic and project variants, c.u./year.

Because the difference of the expenses is observed, the sizes, equal for both variants, are excluded.

Further, observing only the articles of the exploitation expenses that are not identical in basic and projected value, we receive:

$$C_B = C_{kr}^B + C_r^B = \alpha_{kr}^B \cdot k_{ch} \cdot m_B + \beta_r^B \cdot k_{ch} \cdot m_B, \quad (3)$$

$$C_{PR} = C_{kr}^{PR} + C_r^{PR} = \alpha_{kr}^B \cdot k_{ch} \cdot m_{PR} + 2 \cdot \beta_r^B \left(\frac{t}{T_N} \right)^2 \cdot k_{ch} \cdot m_{PR} + C_1 + C_2 + C_3, \quad (4)$$

where:

C_{kr}^B, C_{kr}^{PR} – annual amortization contributions on the capital repair and renovation of the main crane beams, c.u./year,

C_r^B, C_r^{PR} – annual expenses on the middle current repair and the technique service of the main crane beams, c.u./year,

α_{kr}^B – norm of the amortization contribution and the crane beams' renovation,

β_r^B – norm of the annual contributions on the middle repair, current repair of the main beams,

t – current time, in the projected variant norm β_r^B is variable, it grows with time,

C_1, C_2, C_3 – sizes of the expenses, connected with the additive service works of the main beams – the control of the main beams' stage with the aim of the resource-increasing (chapter 2).

Carrying out the scratching of the geometrical beams' parameters (thicknesses of belts, walls, beam's height and width), define the variants' massive of the geometric parameters' complex that corresponds to the limit

$$\Delta \Pi_{\max} \geq \Delta \Pi > 0.9 \Delta \Pi_{\max}. \quad (5)$$

The received information we prove by the sign of corresponding to the values of the parameters' endurance, choose the best variant – the variant that is in the limit of the objective maximum and thus promotes fully to the increasing of the main beams' resource.

2. Definition of the main beams' endurance parameters

Endurance parameter does not pretend on the exclusiveness by the definition of the continuation of the main beams' exploitation, because it is impossible now, when there are absent

even the directions of the task's decision. Because of it the parameters, observed by us, defined by the geometric main beams' parameters, set tendencies to the reducing of the destructive phenomena.

The factors, leading to the destruction of the main beams, are known:

- the action of the exploitation cyclical loads, calling the fatigue destructions of the main beams [1],
- the metal creeping, defining the deformation growth, when the loaded element is influenced by the stretching loads to the beginning of the critical deformation value with the further breaking [2],
- the constructions' blistering appearing owing to the metal maturing [3],
- corrosion of the main beams' elements, leading to the loss of their carrying capacity [4].

3. Action of the cyclic loads

The limit fatigue number of the main beams' load cycles can be defined on the physical modelling base (by presence of the information about the tests of the samples from the corresponding materials) by the condition:

- presence of the correct resemblance criteria,
- possibilities of the equivalent character cyclical sample's loading definition.

For the definition of the main beams' residual resource is necessary:

- to have information about the real character of the crane beams' loading as with statical, so with the static, so with the dynamic efforts,
- to consider that fact that the considerable pauses between the load cycles (it is indicative for all cranes) make incorrect the comparison of the limit number of the model and nature cycles by the condition of the model test in the one-cinema regime.

The methods of the crane beams' residual resource definition [5] persuade that tenths of years must pass before the crane building receives the methodic, proved by the practice, it means the methodic, to results of which we can believe.

Despite of the fact that neither in the literature, nor in the expert conclusions [6] were noticed the cases of the "live" (developing) characteristic fatigue cracks in the zone of the low belt, it is necessary to confirm that the danger of the main beams' fatigue limit achievement exists.

Because of it by the definition of the main beams' optimal parameters, it is necessary to foresee the possibility to eliminate this unclear danger, meaning that the external signs of the fatigue limit are absent.

It is created the device, Fig. 1, allowing defining the deflection sizes and the decay character of the bridge cranes' main beams vibrations. This device works effective.

The basis of the device is the registrar of the linear movements on the optical transducer's base.

The functional scheme of the optical registrar of the linear movements on the optical transducer's base (registrar) is shown on the Fig. 2.

Optical transducer (ADNS 3080) defines the position changing by the consistent scanning of the work surface picture with the speed of 6400 images (frames) in a second, calculates the direction and the movement speed, making 1600 counts on one inch by the maximal movement speed 40 inches in a second. The optical transducer is realized on the DSP (Digital Signal Processor) processor.

The scanning results are analysed and by the changes of the transducer position are defined the corresponding movements by Δx and Δy coordinates. Further, this information is transmitted by four-wired interface to the microcircuit CYPRESS CY7C63743A-PC, realizing the interface of the information transmitting with the external device through PS/2 interface. The electrical scheme of the transducer ADNS3080 connection with CYPRESS CY7C63743A-PC, further there is a transducer controller.

Receiving, procession, information record, also interface realizing between the personal

computer and the device is realized on RISC microcontroller ATmega16 with tact frequency c 16 MHz. The connection of the microcontroller with PC is realized by the communication of the universal consistent asynchrony transceiver USART and RS232/USB convertor.

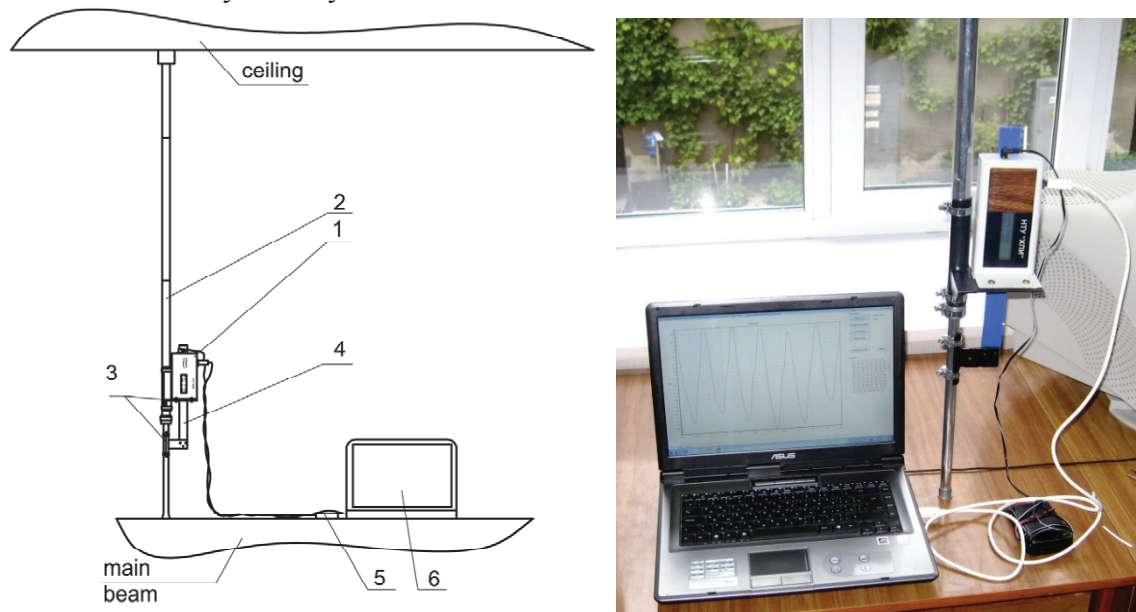

Fig. 1. Device for the size measuring and the decay character of the vibrations of the bridge cranes' main beams
 1 – registrar of the lineal movements on the base of the optical transducer; 2 – regulate spring; 3 – stand for the registering of the linear movements and the line; 4 – line; 5 – power source of the linear movements' register; 6 – notebook with the established program equipment

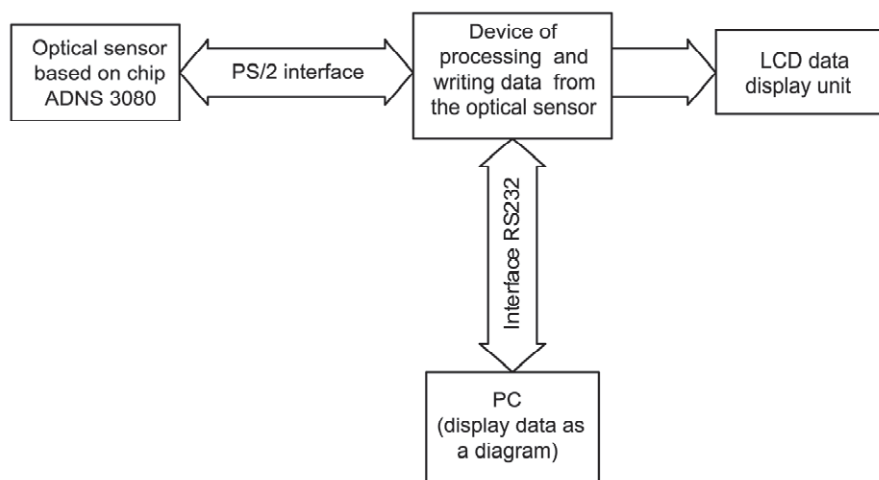

Fig. 2 – Functional registrar scheme

Technical characteristic of the device:

- Vibration amplitude 0...40 mm, error – to 5%,
- Vibration frequency 0...5 Hz, error – to 5%,
- Changing time 0...30 s, error – to 5%.

4. Experimental information of the deflection and bridge cranes' decay time

Measurements of the deflection and the definition of the decay time of vibrations were carried out in the bridge cranes that were in the exploitation with the main beams of the box construction:

- tonnage 5 t, span 16.5 m, 1975 year omission, Burean mechanical plant,
- tonnage 10 t, span 16.5 m, 1986 year omission, machinery plant, city Komsomolsk-on-Amur,

- tonnage 20/5 t, span 22.5 m, 1981-year omission, Uzlovsky machine building plant.
Changing of the deflection and metallic constructions' decay time by the lift of the nominal load is shown on the Fig. 3.

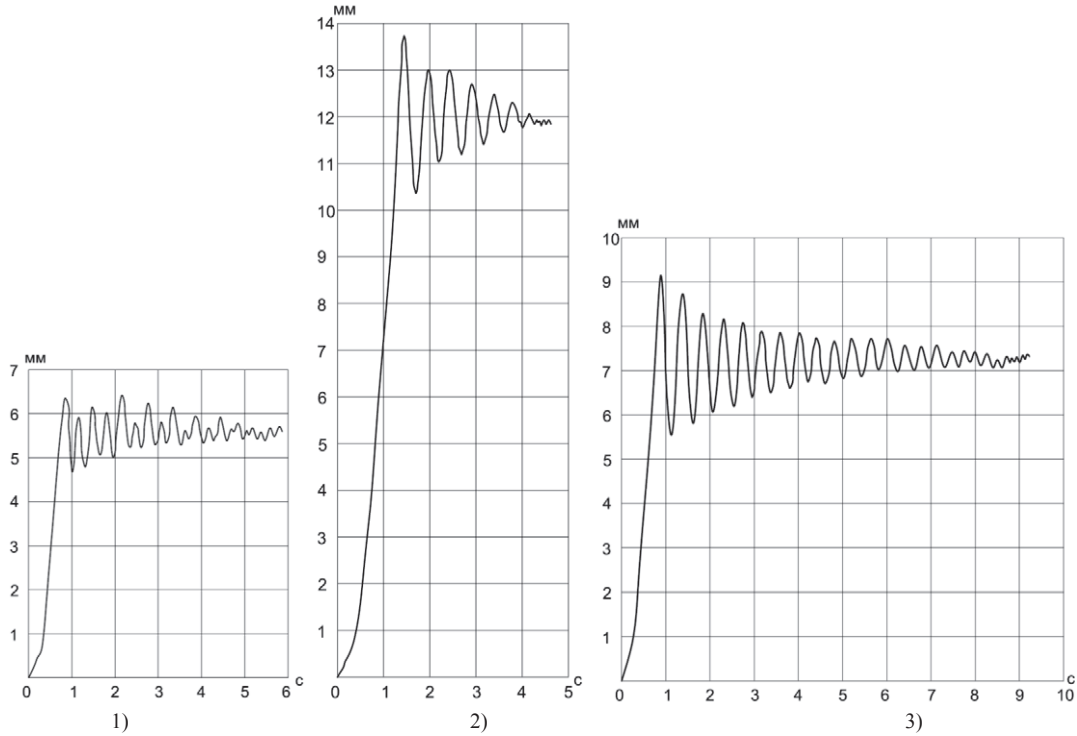

Fig. 3. Changing of the deflection and decay time by the lifting of the nominal load (for cranes No. 1, 2, 3 correspondingly)

The character of the received dependences allow to reduce the dynamical loads, having decreased the reduced mass m_c of the system (in its structure there is also a beam mass m) and having increased the hardness c of the beams, it means, having increased the free system frequency

$$\omega_c = \sqrt{\frac{c}{m_c}} \tag{6}$$

So, as an endurance parameter by the factor 1 acts the size $p_1 = \frac{c}{m_c}$. In addition, this size, defined by the geometrical beam parameters, should be as big as possible. Thus the size of the additive responses by the factor 1 is equal C_1 .

5. Optimization ways

Main work directions by the providing of the rational (optimal) constructive parameters of the main beams are:

- optimization of the main beams' elements constructive parameters of the traditional construction,
- research of the new perspective constructive decisions for the main beams.

On the Fig. 5 is shown the main beams' construction that provides the considerable decreasing of the main beams' steel intensity with the simultaneous increasing of the construction's durability.

Therefore, it is reached the effect of the main beams' "relief" without aggravation of the crane's dynamical characteristics that is indicative by the decreasing of the constructions' steel intensity. It will further allow projecting the steel crane's main beams of the equal resistance without the technological difficulties – Fig. 4.

Into the suggested construction of the span beam [7, 8] are put such statements:

- high values of the general optimization criterion's parameters p ,

- possibility of the beam's creation of the equal resistance,
- minimization of the local deflection tensions from the load cart on account of the inclined walls' position,
- openness of the construction.

Patented construction of the span beam, Fig. 4, contains the upper belt 1, low belt 2 and wall 3 that adjoin to the internal surfaces of the belts 1 and 2. Walls 3 are put successively under the angle α along the lateral beam axis with the opposite inclination of the adjacent walls 3. Angle α is the parameter of the resisting moment of the beam's cross-section and is defined depending from the size of the deflection moment in the corresponding beam's cross-section that is situated in the corresponding beam's sector. Angle α of the wall's inclination to the lateral beam's axis is increased in the direction to the beam's centre C:

Angle α is defined by the formula:

$$\alpha_n = \arccos\left(\frac{(1,2\dots,1,4)\delta_B}{\delta_{REALn}}\right), \quad \delta_{REALn} = \frac{2(3HW_n - Ba^3 - 3Ba(H-a)^2)}{(H-2a)^3}, \quad (7)$$

where:

α_n – angle α in the corresponding beam's sector,

$W_n = \frac{M_n}{[\sigma]}$ – size of the residual moment of the beam's cross-section in the corresponding beam's sector, m^3 ,

δ_B – wall's width in the basic beam's variant, m,

H – beam's height, m,

B – beam's width, m

a – belt's width, m,

M – size of the deflection moment in the corresponding sector, N·m,

$[\sigma]$ – size of the assumed tension, Pa,

n – sector's number, beginning from the beam's centre.

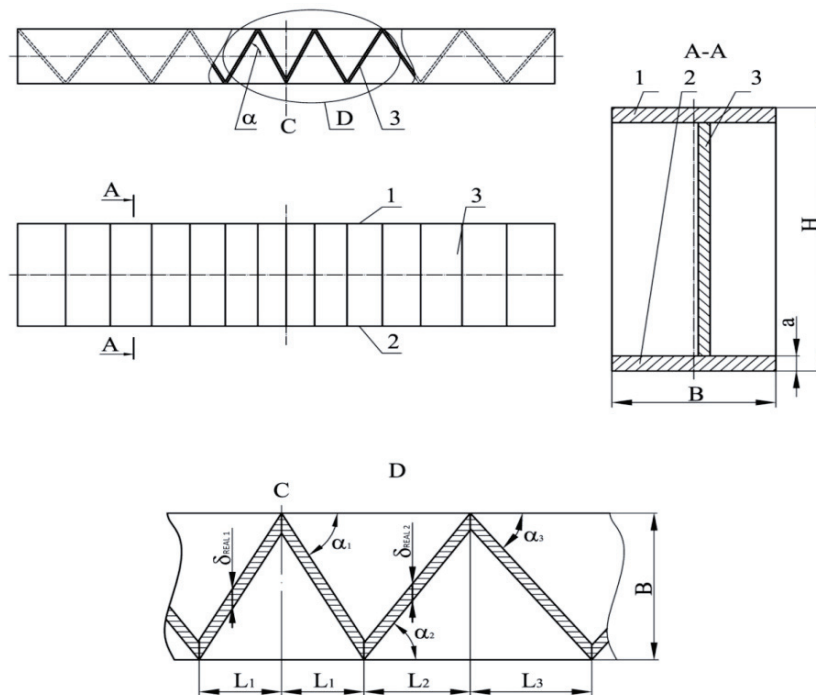

Fig. 4. Span beam [7, 8]

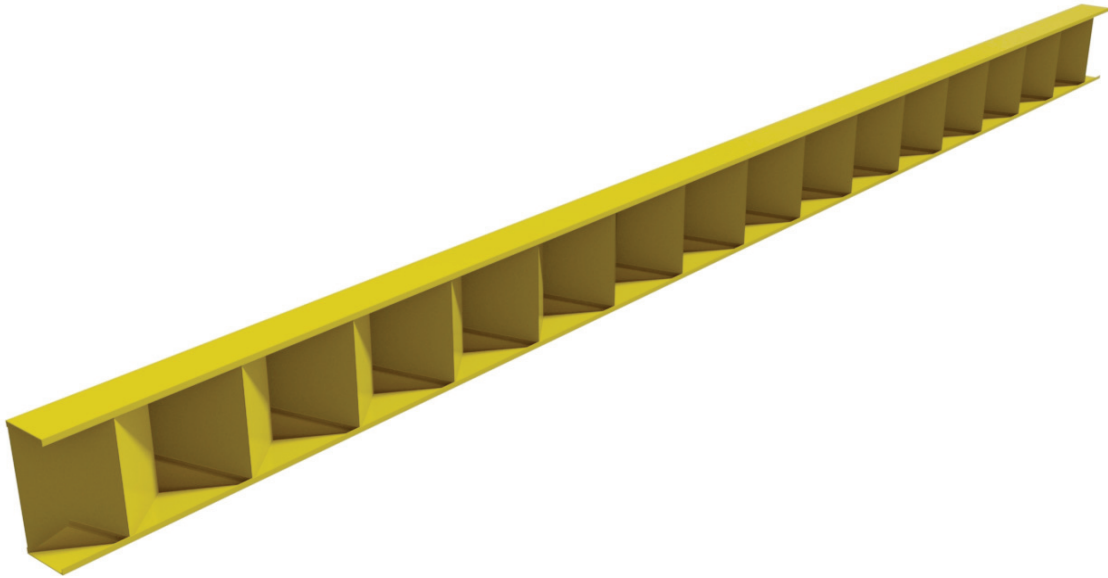

Fig. 5. Span beam of the diaphragm construction

6. Conclusions

Received results confirm the correctness of the lead-up to the choice of the constructions' optimization general criterion. Because of it, the practical works' realization by the modernizing of the main beams' constructive parameters will allow to exclude (lead to minimum) not only the risk of the main beams' destruction, but also receive the bridge cranes with the new customer characteristics.

References

- [1] Augustin, J., Shledzevsky, E., *Accidents steel structures*, Per. from Polish. Stroyizdat M., pp. 184, 1978.
- [2] Pustovoy, B. H., *Steel lifting equipment. Destruction and the residual life prediction*, Transport, pp. 256, 1992.
- [3] Kovalenko, V., Angelica, V., Kovalenko, J. I., *Features of repair corrosion damage to steel cranes*, Lifting equipment, Special equipment, No. 12, pp. 26-27, 2004.
- [4] Sokolov, S., *Metal construction hoisting machines: the manual*, St. Petersburg, University of Technology, pp. 423, 2005.
- [5] Kovalenko, V., Khlystov, E. G., *Impact damage to the elements for overhead cranes for safe operation*, Tesi dopovidey 3 Universitetska naukovyi-praktichna studentsko konferentsiyi magistrant NTU HPI, Delhi: NTU HPI, Part 2, pp. 19-21, 2009.
- [6] *Magnetic control of the stress-strain state and the residual life of lifting equipment during their examination and diagnosis*, Methodical instructions. RD ICC Crane -007-97-02, pp. 57, Moscow 2003.
- [7] *Beam purlins*, The patent for vinahid UA No. 94011, Bull. Number 24. 25.03.2011.
- [8] *Span bridge girder*, A patent for an invention RU No. 2467945, Bull, No. 33. 27/11/2012.

