

**Krzysztof STANKIEWICZ\***

Department of Mechatronics Systems, Institute of Mining Technology KOMAG, Gliwice, Poland

\* Corresponding author: kstankiewicz@komag.eu

## MINING CONTROL SYSTEMS AND DISTRIBUTED AUTOMATION

© 2018 Krzysztof Stankiewicz

This is an open access article licensed under the Creative Commons Attribution International License (CC BY)

<https://creativecommons.org/licenses/by/4.0/>**Key words:** automation, control, mining, distributed systems.

**Abstract:** Distributed monitoring, control, and automation systems, often able to adapt and learn, are more widely used in industrial practice. Due to constantly increasing needs of safety and reliability of exploitation the area of smart systems applications in the Polish hard coal mining sector is also growing. At the KOMAG Institute of Mining Technology, the development and implementation of distributed control and automation systems in mining machines are carried out. To successfully develop these systems, the CAN communication bus, made as an intrinsically safe circuit, is used. The implementation of a distributed structure and an intrinsically safe CAN bus has a number of advantages, such as flexibility and the possibility of expansion (open systems). The publication presents selected problems related to the projects carried out by the KOMAG Institute of Mining Technology in cooperation with KOPEX MACHINERY S.A., JSW S.A. and Gabrypol Sp. J.

### Górnictwo systemy sterowania i automatyzacji rozproszonej

**Słowa kluczowe:** automatyzacja, sterowanie, górnictwo, systemy rozproszone.

**Streszczenie:** Systemy monitoringu, sterowania i automatyzacji rozproszonej, często zdolne do adaptacji i uczenia się, są coraz szerzej stosowane w praktyce przemysłowej. Ze względu na potrzebę zwiększenia niezawodności i bezpieczeństwa eksploatacyjnego wzrasta również obszar zastosowań systemów inteligentnych w polskim górnictwie węgla kamiennego. W Instytucie Techniki Górniczej KOMAG prowadzone są prace rozwojowe oraz wdrożeniowe dotyczące układów sterowania rozproszonego i systemów automatyzacji w maszynach górniczych. Wykorzystuje się w tym celu głównie magistralę komunikacyjną CAN wykonaną jako obwód iskrobezpieczny. Zastosowanie struktury rozproszonej oraz iskrobezpiecznej magistrali CAN ma szereg zalet takich jak elastyczność i możliwość rozbudowy (układy otwarte). W publikacji przedstawiono wybrane problemy dotyczące prac realizowanych w Instytucie Techniki Górniczej KOMAG, we współpracy z KOPEX MACHINERY S.A., JSW S.A. i Gabrypol Sp. J.

## Introduction

Due to the constant striving to increase the safety of mining crews and improve the efficiency of mining, transport, and coal processing, the KOMAG, Institute of Mining Technology, aiming the research projects at implementation of state-of-the-art control systems and self-organizing, a self-powered and wireless network of sensors are realized. A wireless network of sensors can cooperate with the control systems or operate alone. A system of distributed sensors, e.g., battery supplied

pressure sensors communicating with each other through the wireless network, are known on the mining market [1, 2]. There are the following reasons justifying the use of wireless, distributed, self-organizing control systems, and sensor networks in the mining industry:

- Wide-spread technical systems installed in mine roadways, e.g., belt conveyors for the transportation of the run-of-mine of lengths from hundreds of meters up to few kilometres;
- Dynamic changes in the configuration of machine hardware resulting from the advance of mining work; and,

- Efforts aiming at automation and autonomation of minerals mining technologies.

However, the design of self-organizing, distributed wireless sensors networks and control systems requires the development of an alternative method for power supply of its components through harvesting energy available in its vicinity, e.g., the energy of mechanical vibrations, thermal energy [3, 4], and the energy of rotational movement or electromagnetic radiation. The development of electronic systems of low energy consumption and the development of radio data transmission standards facilitate using wireless, battery supplied, or self-powered sensors [5, 1]. Self-powered sensors are more commonly used in ventilation or air-conditioning systems and in monitoring the migration of animals and also in the systems monitoring the technical parameters.

Artificial intelligence is more and more commonly used for machine communication in the mining industry, for monitoring and diagnostics of subassemblies and component wear [6–9] and in the machines control systems and mechanization systems [10, 11]. According to ITG KOMAG experiences, three hardware and software components of the discussed solutions are mostly important due to operational reliability: self-powering sensors, distributed control systems, and self-organizing communication network gathering these components to the system.

---

## 1. Self-powered sensors

---

Self-powered sensors are equipped in generators, converting the energy in its neighbourhood into electric energy. Depending on the generator design, the self-powered sensors can be supplied by energy of light, gas flow, mechanical vibrations, or electromagnetic radiation. Electromagnetic or piezoelectric generators are most often used for conversion of mechanical vibration energy [12].

Energy harvesting enables the recovery of energy, securing the communication between wireless sensors [13]. Research on wireless sensors, which do not require a fixed source of energy, have been intensively developed in the last decade [14–17].

The investigations are carried out in the following three main directions:

- The organization of radio communication [18],
- The minimization of energy consumption by electronic components, and
- Power supply system [19].

For example, the research projects on power supplies are focusing on the development of components for energy storage (batteries, cells, supercapacitors) and mini-generators supplied by renewable energy or waste energy [12]. Self-powered sensors communicate with master devices through radio transmission systems of

low energy consumption (usually it is Bluetooth Low Energy standard).

---

## 2. Intelligent computer communication networks

---

The mining industry is one of the important sectors of the Polish economy, where there are strong challenges and demands regarding the automation of machines and technological processes and requirements for improving health protection and safety. Regarding the mining industry, artificial intelligence can be used, among others, in the monitoring and diagnostics of components and subassemblies wear [7, 20–23] and in the control of machines and mechanization systems [24, 25]. Future mining of the seams with high methane content, threatened by impacts and high temperatures, forces the designers to develop autonomous systems to withdraw personnel from dangerous zones and to reduce the role of human beings mainly to supervision activities.

Operational problems described above have an impact on control systems and the safety of mine transportation. Research projects aiming at increasing the reliability of those machines and at permanent monitoring are known [12, 18, 26]. Work on the development of technical solutions that enable reliable supervision of the transportation machines is also being carried out [8, 27, 28]. Information on the rotational speed, vibrations, and temperature of critical nodes of machines and monitoring in a real time are of key importance for work safety in underground workings, especially in regards to fire hazards.

After the acquisition, a wireless communication system between the machines (Ad Hoc communication) transferring data to the central computer is the last stage of the measuring cycle. Bearing in mind the number of monitored nodes installed in transportation system, the measuring grid has a complex structure of mesh topology. In such grids, we more frequently find the implementation of routing protocols based of artificial intelligence technology and methods. Effective routing is especially important in the case of grids of mesh topology with implemented a Ad Hoc mechanism. Ad Hoc networks are often multi-hop structures, where very low throughputs can be found between nodes and communication can be realized only in one direction. The grids of the complex structures have many problems that must be solved. Most important of them are as follows [11, 14–16, 29–34]:

- Mobility,
- The number of data packages hops,
- Self-organization,
- Saving energy,
- Scalability, and
- Safety.

### 3. Routing protocols in Ad Hoc networks

A routing protocol ensures the passage of data packages from the source node to the target node. Bearing in mind the mentioned limitations of an Ad Hoc network, the realization of this task is not easy. Many different routing protocols, which can be implemented in Ad Hoc mobile networks, are available. The existing solutions can be classified as the following [22, 26, 29, 32, 34, 35]:

- Proactive protocols, where routes are stored in routing tables.
- Reactive protocols are also known as routing protocols on demand.
- Hybrid protocols combine the properties of proactive and reactive protocols.

### 4. Concept of the self-organizing structure of sensor network

The author's concept of self-organizing communication structure, named SSKIR [13], is based on one of artificial intelligence technologies, "swarm intelligence," which is a direct implementation of phenomena and behaviour in nature among organisms living in large groups. Their behaviour, to some extent, can be transferred to the operation of routing protocols. The system structures developed by humans (irrespectively to real implementation), using the swarm algorithm, have high possibilities for adaptation and high operational reliability. In 1987, during the SIGGRAPH conference, the programmer Craig Reynolds, in the paper entitled "Flocks, Herds, and Schools: A Distributed Behavioural Model," suggested three basic rules of self-organization based on observed groups of animals, as follows [8]:

- Collision avoidance is control eliminating a local concentration of individuals. Collision avoidance eliminates accumulation of hardware and decision structures.
- Flock centring are actions towards the average behaviour of local groups of individuals.
- Velocity matching rules are actions towards the average objective of local groups of individuals. Velocity matching enables the individual to adapt its actions to other individuals from its local group.

Based on the above rules, the creation of a communication system made of a sensor network in which routing is based on a swarm algorithm was suggested [13]. Each data frame transferred by the Measure Transmission Unit (MTU) is marked by a quality coefficient WP specifying the transmission priority referring to the effectiveness of data transmission to the main transceiver stations. This coefficient can take a value that conforms to one of connections or path metrics [26, 32].

Additionally, the following principles resulting from swarm phenomena are assigned to each data package so that the system can react to changes in a node structure (failures, nodes displacement):

1. The package matches its speed to the packages moving in paths of higher WP coefficient.
2. The package uses the path parallel to the optimal route (of highest known WP value), if its WP decreases.
3. The package uses the optimal path (of higher known WP value), if the WP coefficient of the current route decreases.
4. The package avoids transmission through the nodes that are marked as damaged.
5. The package can leave the present path, if the main transceiver station is found.

Local data, which is indispensable for the realization of tasks resulting from the above principles, are calculated and stored in nodes. There is no need to create a master routing table. The use of these rules causes that the group of MTUs creating the transmission connection automatically develops the structure of reliable transmission routes while neglecting the damaged units.

### 5. KOGASTER control and diagnostics system

R&D projects, realized in KOMAG, enabled the development of distributed control system modules of trade name KOGASTER. KOGASTER is a good example of a system which is able to include and unite, mentioned above, self-powered sensors and wired/wireless computer communication networks, and is implemented in a harsh mining environment. It is intended to be used in the machines operating in difficult conditions, especially in a potentially explosive atmosphere, where the use of intrinsic safe automatic systems designs is required. The KOGASTER system was certified, and its components are to be implemented in mining industry, where danger of methane explosion and coal dust explosions occurs. The system was designed to operate in accordance with the operating parameters set by the manufacturer, providing a high level of protection (switching off the power in the event of an explosive atmosphere and guarantee the required level of protection of each worker during normal operation, and in difficult operating conditions, in particular, due to improper use and changing environmental conditions). KOGASTER is protected by intrinsic safety and ignition source control, thus its components are classified as explosion Group I. For example, the PO-1 control panel of the KOGASTER system has obtained the following category: I M2(M1) Ex ib [op is Ma] I Mb. The KOGASTER control system

developed in KOMAG Institute of Mining Technology is manufactured by Gabrypol Sp. J. [23]. The following are the characteristics of the system: open structure, distributed design, compatibility with transducers and modules made by different manufacturers, which enables controlling different machines. Open structure enables combining the KOGASTER system components with the components (transducers, sensors) made by other manufacturers and using the universal software for its configuring. Components of the KOGASTER system can be used in the machines with both intrinsically and extrinsic safe circuits.

The KOGASTER control and diagnostics system is a distributed system using CAN bus and CANopen protocol [21, 33] for communication. It is used for local control in mining machines and equipment [4, 5, 20, 27, 28, 30, 31]. Use of CAN bus and CANopen protocol [21, 33] caused that this is an open system. The following are characteristic features of the KOGASTER control system:

- Distributed structure [19];
- Intrinsically safe, redundant CAN bus [13];
- Intrinsically safe manufacture of system modules [23].

## 6. Structure of distributed control system

The Structure of the distributed control system consists of control modules, inputs-outputs, measuring transducers, and actuating components and digital interface, connected with digital CAN bus. The possibility of power supply and data transmission in one bundle of wires is an advantage of this solution. A block diagram of the distributed control with the use of single CAN is presented in Fig. 1.

The reliability of distributed system is achieved by the redundancy of CAN bus and doubling the modules and transducers. That increases unit manufacture cost but enables decrease costs resulting from possible breakdowns caused by machine failure. A battery powered locomotive equipped with two independent control panels and two drives, presented in Fig. 2, can be an example.

Two PO-1 modules installed in cabin A and B, which play the role of the operator's panel and controller, are the main components of redundant control system. The modules are equipped with two CAN intrinsically safe interfaces securing galvanic separation and a possibility of power supply from two independent intrinsically safe feeders. The control systems with redundancy enable increasing the number of machine safe operational modes.

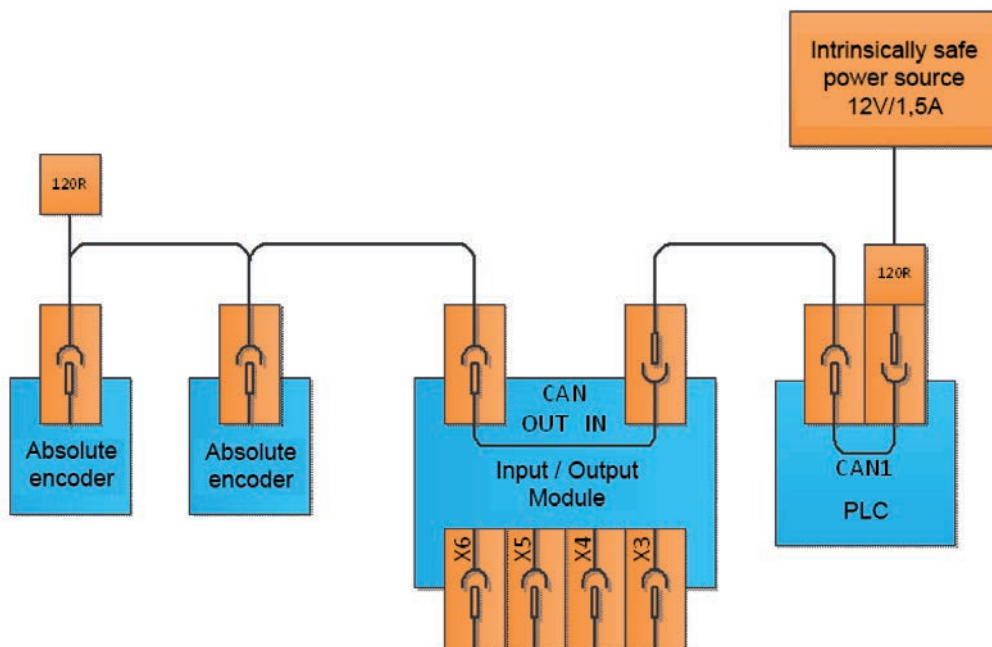

Fig. 1. Block diagram of distributed control system using a single CAN bus [24]



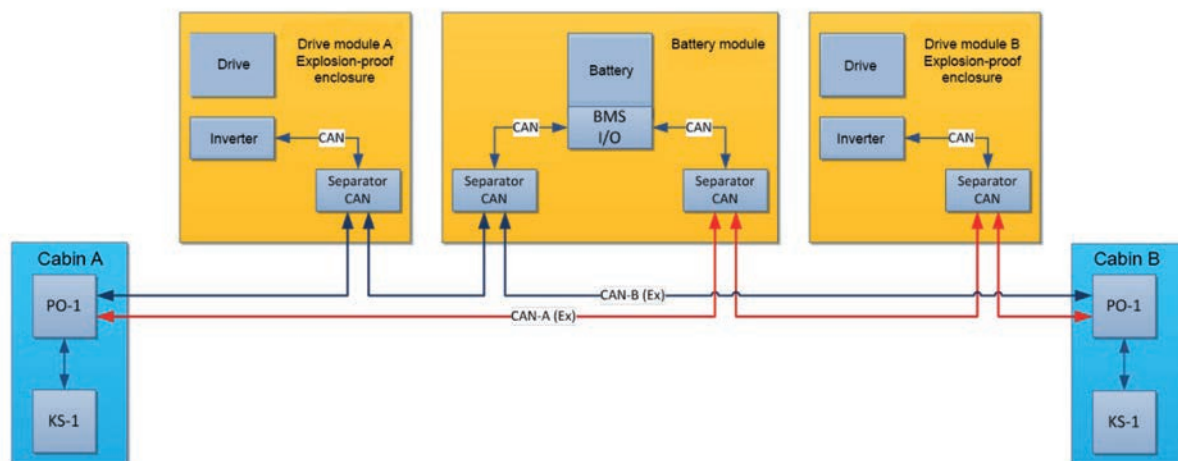

Fig. 2. Block diagram of a locomotive control system with a redundant distributed structure [24, 35]

## Summary

Control and monitoring systems, capable of adaptation and learning, are increasingly used in industrial practice. Internet of Things (IoT) techniques and direct communication M2M (Machine to Machine) are increasingly affecting the structure and functionality of control systems used in machines, shaping the idea of Industry 4.0.

The practical use of energy harvesting is possible due to the implementations of electronic circuits with low energy demands, which enables the management of energy coming from low power sources to supply wireless sensors operating in self-organizing networks.

An example of a control system with a distributed architecture is the KOGASTER control system based on the CAN bus and the CANopen protocol. The use of intrinsically safe devices in the KOGASTER system enables its implementation to control machines and devices operating in zones where there is a risk of methane and coal dust explosions.

The method of the self-organization of the communication system based on a swarm algorithm enables implementing a state-of-the-art and effective routing technology in the networks of mesh topology, including those used in underground mines, especially in diagnostic systems, monitoring, and in the protection of machines; and subassemblies of the networks equipped with MTU nodes can be treated as the components of a measuring swarm. This is especially important in work safety in underground mines due to the reliability of mesh networks.

## References

1. Tanenbaum A.S., Stehen M.V.: Systemy rozproszone. Zasady i paradygmaty. Kłasyka informatyki. Warszawa: WN-T, 2006 (in Polish).
2. Wischke M., Masur M., Kröner M., Woias P.: Vibration harvesting in traffic tunnels to power wireless sensor nodes. *Smart Materials and Structures*, 2011, 20(8), 085014.
3. Stankiewicz K., Woszczyński M.: Metody odzyskiwania i przetwarzania energii cieplnej. *Maszyny Górnicze*, 2010, 1, pp. 39–46 (in Polish).
4. Woszczyński M., Świder J.: Use of the System for Energy Recuperation and Control in Diesel Machines. *Machine Dynamics Research*, 2014, 38(1), pp. 73–79.
5. Sudevalayam S., Kulkarni P.: Energy Harvesting Sensor Nodes: Survey and Implications. *IEEE Communications Surveys & Tutorials*, 2011, 13(3), pp. 443–461.
6. Boukerche A.: Algorithms and Protocols for Wireless and Mobile Ad Hoc Networks. Ottawa: Wiley, 2009.
7. Jasiulek D., Stankiewicz K., Jagoda J.: Możliwości zastosowania czujników samozasilających się przeznaczonych do pracy w podziemiach kopalń. *Mechanizacja i Automatyzacja Górnictwa*, 2013, 8(519), pp. 73–80 (in Polish).
8. Reynolds C.W.: Flocks, Herds, and Schools: A Distributed Behavioral Model. Anaheim: SIGGRAPH, 1987.
9. Vullers R.J.M., van Schaijk R., Doms I., Van Hoof C., Mertens R.: Micropower energy harvesting. *Solid-State Electronics*, 2009, 53 pp. 684–693.
10. Cunefare K.A., Skow E.A., Erturk A., Savor J., Verma N., Cacan M.R.: Energy harvesting from hydraulic pressure fluctuations. *Smart Materials and Structures*, 2013, 22(2), pp. 729–738.

11. Latos M., Stankiewicz K.: Studies on the effectiveness of noise protection for an enclosed industrial area using global active noise reduction systems. *Journal of Low Frequency Noise, Vibration and Active Control*, 2015, 34(1), pp. 9–19.
12. Jonak J., Prostański D., Jasiulek D., Rogala-Rojek J., Puchała B.: Koncepcja adaptacyjnego układu sterowania w kombajnach chodnikowych REMAG SA. In: Krauze K. (ed.): *Problemy Bezpieczeństwa w Budowie i Eksploatacji Maszyn i Urządzeń Górnictwa Podziemnego*. Łędziny: Centrum Badań i Dozoru Górnictwa Podziemnego, Łędziny 2010, pp. 115–123 (in Polish).
13. Stankiewicz K.: Self-organization of network structure based on swarm algorithms. *Problemy Eksploatacji. Maintenance Problems*, 2014, 2, pp. 5–14.
14. Legutko S.: Development trends in machines operation maintenance. *Eksploatacja i Niezawodność – Maintenance and Reliability*, 2009, 2, pp. 8–16.
15. Misra S., Misra S.C., Woungang I.: *Guide to Wireless Ad Hoc Networks*. London: Springer-Verlag, 2009.
16. Mitcheson P.D., Rao G.K., Green T.C.: Energy Harvesting From Human and Machine Motion for Wireless Electronic Devices. *Proceedings of the IEEE*, 2008, 96(9), September 2008, pp. 1457–1486.
17. Wang Z.L.: Self-Powered Nanosensors and Nanosystems. *Advanced Materials*, 2012, 24(2), pp. 280–285.
18. Jasiulek D.: Propozycje zastosowania czujników samozasilających się w przemyśle wydobywczym. *Przegląd Górniczy*, 2014, 70(1), pp. 9–15 (in Polish).
19. Zhu D., Beeby S.P., Tudor M. J., Harris N.R.: A credit card sized self powered smart sensor node. *Sensors and Actuators A: Physical*, 2011, 169(2), pp. 317–325.
20. Bartoszek S., Jagoda J., Jura J., Latos M.: Systemy wbudowane w zespołach sterowania, diagnostyki oraz wizualizacji dla górnictwa. In: Klich A., Koziół A. (eds.): *Innowacyjne techniki i technologie dla górnictwa Bezpieczeństwo – Efektywność – Niezawodność. KOMTECH 2014*. Gliwice: Instytut Techniki Górniczej KOMAG, 2014, pp. 207–218 (in Polish).
21. Gładysiewicz L., Król R., Bukowski J.: Tests of conveyor resistance to motion. *Eksploatacja i Niezawodność – Maintenance and Reliability*, 2011, 3, pp. 17–25.
22. Ilyas M.: *The Handbook of Ad Hoc Wireless Networks*. Florida: Florida Atlantic University, 2003.
23. Sazonov E., Li H., Curry D., Pillay P.: Self-Powered Sensors for Monitoring of Highway Bridges. *IEEE Sensors Journal*, 2009, 9(11), pp. 1422–1429.
24. Gilbert J. M., Balouchi F.: Comparison of Energy Harvesting Systems for Wireless Sensor Networks. *International Journal of Automation and Computing*, 2008, 5(4), pp. 334–347.
25. Sarkar S.K., Basavaraju T.G., Puttamadappa C.: *Ad Hoc Mobile Wireless Networks. Principles, Protocols, and Applications*. Second edition. Boca Raton: CRC Press, Taylor & Francis Group, 2012.
26. Feeney L.M.: *A Taxonomy for Routing Protocols in Mobile Ad Hoc Networks*. SICS Technical Report T99/07, Kista, 1999.
27. Mohapatra P., Krishnamurthy S.V.: *Ad Hoc networks (Technologies and Protocols)*. Springer, 2005.
28. Radkowski S., Lubikowski K., Piątek A.: Vibration Energy Harvesting in the Transportation System: a Review. *Diagnostyka – Applied Structural Health, Usage and Condition Monitoring*, 2012, 4(64), pp. 39–44.
29. Arabshahi P., Gray A., Kassabalidis I., Das A., Narayanan S., Sharkawi M., El Marks R.J.: Adaptive routing in wireless communication networks using swarm intelligence. In: *AIAA 19th Annual Satellite Communications System Conference, Toulouse (France)*, 2001. *Proceedings of 19th AIAA International Communications Satellite Systems Conference*, pp. 1–9.
30. Bartoszek S., Jagoda J., Jura J.: System diagnostyczny ładowarki bocznie wysypującej bazujący na iskrobezpiecznej magistrali CAN. *Szybkobieżne Pojazdy Gąsienicowe*, 2013, 32(1), pp. 47–56 (in Polish).
31. Basagni S., Conti M., Giordano S., Stojmenovic I.: *Mobile Ad Hoc Networking*. New Jersey: IEEE Press, 2004.
32. Batko W., Borkowski B., Głocki K.: Application of database systems in machine diagnostic monitoring. *Eksploatacja i Niezawodność – Maintenance and Reliability*, 2008, 1, pp. 7–10.
33. Gong T., Tuson A.L., Particle swarm optimization for quadratic assignment problems – a formal analysis approach. *International Journal of Computational Intelligence Research*, 2008, 4, pp. 177–185.
34. Jonak J., Gajewski J.: Operating diagnostics and monitoring issues of selected mining belt conveyers. *Eksploatacja i Niezawodność – Maintenance and Reliability*, 2006, 4(23), pp. 74–78.
35. Słoczyński J.: *Untypical routing algorithms [Master's thesis]*. Lodz University of Technology, 2004.