

*tool temperature, tool life,
tool material heat generation,
frictional coefficient*

Ye Htut SOE¹
Ikuo TANABE¹
Tetsuro IYAMA¹
Thang Binh HOANG¹

TOOL TECHNOLOGY TO REDUCE CUTTING HEAT GENERATION AND ITS INFLUENCES

Recently, the use of hard materials has increased for product quality and safety reasons. Consequently, the cutting conditions for these materials become severe resulting in shorter tool life due to higher cutting temperature. In this paper, tool technology to reduce heat generation and its influences during cutting is investigated and evaluated experimentally. The approach for reducing cutting heat generation is considered by changing the tool geometry and reducing the frictional coefficient between tool and chip. The approach for reducing influence of the generated heat is application of a thermal insulator (coating) on the tool material having high thermal conductivity and heat-resistance. The turning process is used in the experiments. The thermal influences are made clear by each experimental parameter and then, the optimum tool parameters were considered from experimental results. It is concluded that; (1) When rake angle was 15 degree, temperature rise on the tool was smallest. (2) Temperature rise on the tools coated with TiAlN or DLC (Diamond Like Carbon) were reduced from 20 % to 30 %. (3) Several tool materials were quantitatively evaluated by consideration of the thermal conductivity, as well as thermal dependency of their hardness.

1. INTRODUCTION

Recently, the materials with high hardness become largely used for improvement of the product quality and safety. The cutting condition for these materials is also severe for high productivity. The heat generated during cutting these materials causes extremely large thermal effect and shortens the tool life.

In this paper, two approaches are considered and evaluated for turning tools with: (1) Reducing the cutting heat generation (2) Creating resistance to the effect of cutting heat Three kinds of solid lubrication agents are coated on the cutting tool and tested for their thermal effectiveness. The use of a water cooling mechanism for application of DLC (Diamond Like Carbon) coating layer applied on the rake surface is also investigated.

¹ Nagaoka University of Technology, Dept. of Information Science and Control Engineering, Japan

² Nagaoka University of Technology, Dept. of Mechanical Engineering, Japan

³ Nagaoka University of Technology, Educational affairs section, Mechanics and Machinery Group, Japan

2. THE PROBLEMS REGARDING TOOL TEMPERATURE RISE

Most metals soften with rise in temperature [3]. The relation between temperature and thermal softening factor for moulding materials SKD11, SKD61 and V10 are shown in Fig. 1 [6]. From this figure, it can be known that most of the metals have an approximately straight line relation between temperature and softness with a negative slope. This means that, when the temperature of a material is raised to half the melting point, its yield stress will be decreased to half and the cutting resistance of the material will also become nearly half.

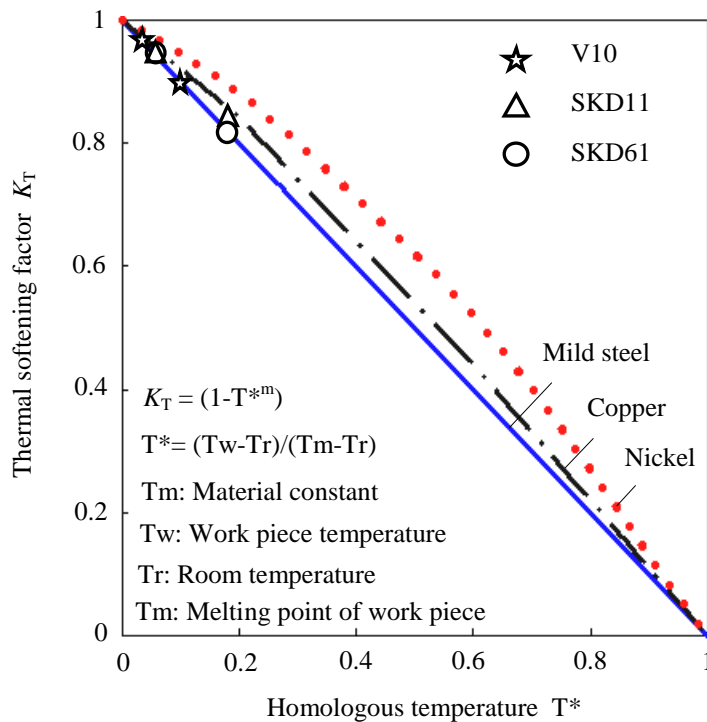

Fig. 1. Relationship between the temperature and the softening factor of some moulding materials

3. CONSIDERATION FOR REDUCING CUTTING HEAT GENERATION

In this section, the optimum tool geometry for reducing heat generation at shear plane and the effectiveness of solid lubricant for reducing the frictional heat generation between the chip and cutting tool will be considered.

3.1. HEAT GENERATION AT SHEAR PLANE (PLASTIC DEFORMATION)

The plastic deformation of work-piece material at the shear plane during cutting causes heat generation in turning. Normally, this generated heat conducts only to the work piece and the chip, with no direct effect on the cutting tool. However, the frictional coefficient

between chip and tool may change depending on the temperature of chip and tool at shear plane. And thus, the tool is indirectly affected by this generated heat during plastic deformation. Therefore, in this section, the effect of the generated heat on shear plane is investigated.

Generally, the material properties of a work-piece cannot be changed to reduce of heat generation. Moreover, changing cutting conditions will also affect productivity. For these reasons, the approach is restricted to modify only the tool specification. Among tool geometries, the rake angle is a factor that directly affects heat generation at the shear plane [4]. Moreover, it also influences the contact length of chip to the rake surface. Therefore, the effect of rake angle on tool temperature is investigated here.

Fig. 2 shows the photograph of experimental setup using a normal lathe. The experiments are taken using, work piece S45C, carbide tool and the cutting conditions as shown in Table 1. The different rake angles of 0° , 15° , 30° are used in the experiment. The temperature at steady state condition are measured and compared. As the direct

Table 1. Cutting conditions and materials used in experiments

Material of work piece	S45C	Al
Cutting speed	150 m/min	200 m/min
Cutting depth	1 mm	1 mm
Feed speed	0.2 mm/rev	0.2 mm/rev
Rake angle	0° , 15° , 30°	15°
Material of tool (tip)	Carbide (P20) Carbide (S10) Cermet Ceramics (Al_2O_3)	Carbide (S10)
Geometry of tip	CNMG120408	
Holder	PCLNR 2525M12	

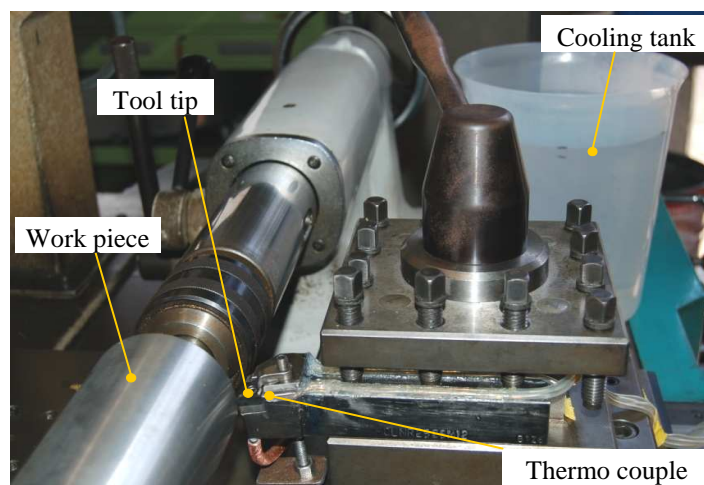

Fig. 2. Photograph of the experimental setup

measurement of temperature at tool tip (cutting point) is quite difficult, the temperatures at two places near to the tool tip are measured using two thermocouples and the tool tip temperature is extrapolated using FEM simulation. The FEM simulation model and analysis conditions are shown in Fig. 3 and Table 2, respectively. The extrapolation method is, firstly, heat flux q is set at tool-chip interface according to the cutting condition. And then, simulation is done with repetition, till the temperature distribution curve fits to one of the two measured points, and the correct amount of heat q is acquired. The convection heat transfer coefficient used in the analysis is the result obtained by measuring with heat flow sensor in the experiment.

Fig. 4 shows the relation between the rake angle and the tool tip temperature. The tool tip temperature for the tool with rake angle 15° is the lowest. It can be considered that, cutting heat generation at shear plane becomes smallest at this rake angle causing less softening of chip, lower frictional coefficient and results in smaller frictional heat generation. And the next fact is tool-chip contact area becomes smaller and also causing less frictional heat generation. Thus, the controlling rake angle is capable of suppressing the temperature rise of the tool tip by about 10%.

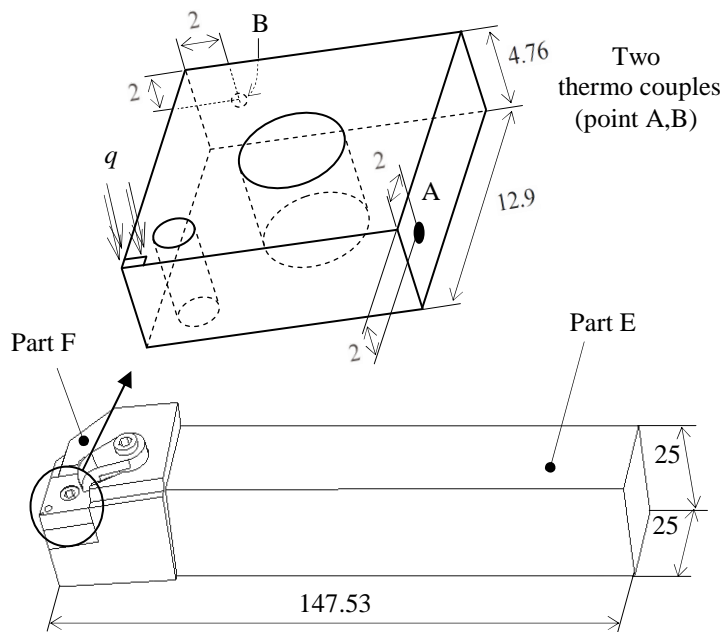

Fig. 3. FEM simulation model for calculation of tool tip temperature

Table. 2. Analysis conditions for calculation of tool tip temperature

Material of holder	Steel
Material of tip	Carbide
Room temperature	20 °C
Heat transfer coefficient on Part E	7.5 W/m ² K
Heat transfer coefficient on Part F	50 W/m ² K

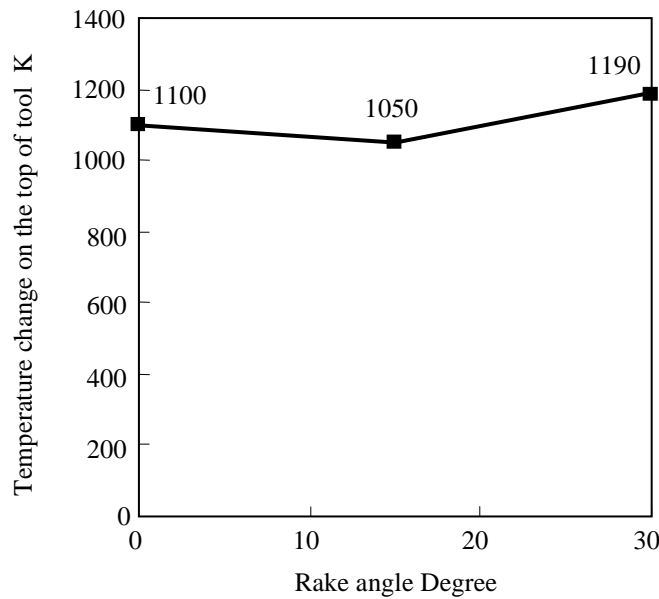

Fig. 4. Relationship between rake angle and tool tip temperature

3.2. HEAT GENERATION AT RAKE FACE (FRICTIONAL HEAT)

In this section, the reduction of tool tip temperature by reducing friction will be investigated. Concretely, solid lubricant with less frictional coefficient is coated on the rake face for reducing friction. The coating is also applied to the flank face, so that to reduce the frictional heat between work piece and flank face. Although reducing friction by using cutting fluid was also considered, the chip usually occupies space at the tool tip during cutting and it is therefore very difficult to supply coolant to this point [1] and this effect is also indirect. Thus, only dry cutting is chosen for this experiment. The effectiveness of the reducing of frictional coefficient is investigated for TiAlN, DLC (Diamond Like Carbon), Ti_3N_4 coating materials on carbide (S type) cutting tools.

The method for measuring frictional coefficient [7] is shown in Fig. 5. The test slices are three round disks of S50C (surface roughness R_z 1.6 μm), diameter 8 mm and thickness 1 mm are coated with solid lubricant of thickness of 1.0 μm and distributed at 120° apart and placed under an acrylic round disk of 40 mm diameter. The apparatus is constructed with electronic scale, linear moving stage, pulley, base surface and sliding body (hereafter called boat). Boat and weight are connected with stainless wire passing through pulley. The generated frictional force between the base surface and test piece for light weight and heavy weight are measured by electronic scale when linear moving stage is moved. From these measurements, the coefficient of friction μ can be described as follow.

$$\mu = \frac{M - M'}{m} \quad (1)$$

Here, M is weight value before moving, M' is the weight value at moving condition after start, m is the weight of the boat, μ is the coefficient of friction.

The measured results are shown in Table 3. The results are not much difference for heavy weight and light weight. The frictional coefficients for TiAlN and DLC are small enough and approximately 1/2 comparing with S50C without applying coating. Thus, it is possible to reducing the frictional heat at the tool tip temperature. In addition, frictional coefficient of DLC can be reduced more by adding water lubrication. Thus here, it is made to be considered this effect.

Fig. 6 shows the apparatus for supplying water to the place nearest to the tool tip for preservation of DLC coating on the tool. A hole of diameter $D=2\text{mm}$ is opened at the distance $X=3\text{mm}$ from the tool tip. This hole is connected with water tank through tool holder. The water inside this hole evaporates while cutting and this amount of water will be automatically replenished from the water tank by means natural movement of water. To maintain the water level L of the water tank, the water from the backup tank is supplied continuously and automatically. The volume of water tank is quite large comparing with the volume of water inside the hole at tool tip. Therefore, it is capable of replenishing for long cutting interval maintaining the same water level.

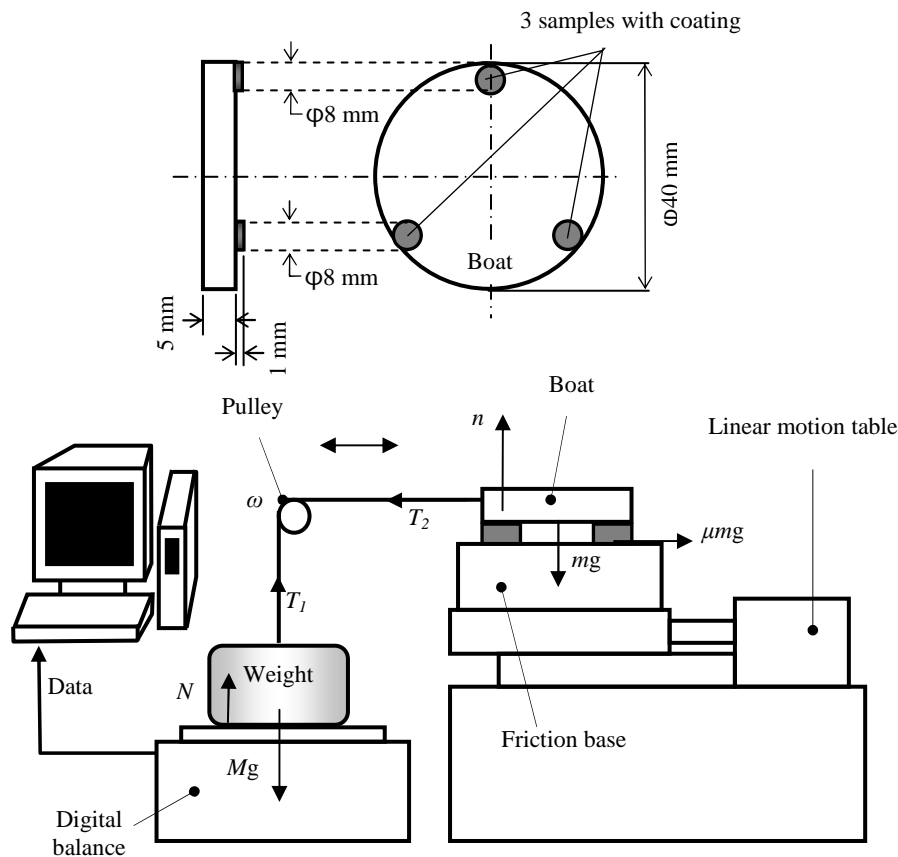

Fig. 5. Schematic view of the equipment for measuring coefficient of friction

The water supplying for improvement of lubrication affect of DLC, is done by using this system. To investigate the effectiveness of reducing frictional coefficient by DLC only, the experiment using tool without coating DLC with only supply water is taken and this cooling effect is subtracted from the previous result.

The experiment is done using same apparatus, cutting condition and the work piece of S45C and aluminium are used. The tool tip temperature is extrapolated by FEM simulation and the results for various types of solid lubricants are shown in Fig. 7. From the results, it is revealed that, even though Ti_3N_4 , is being used as a general coating material regarding for tool wear for its hardness, it can also applicable for reducing frictional heat for about 20%. And, $TiAlN$ is capable of reducing frictional heat about 30%.

Table 3. Frictional coefficient for various kinds of solid lubricants

Applied load	1900 N/m ²	508900 N/m ²
Solid lubricant	Frictional coefficient	
DLC	0.15	0.15
DLC + Water	0.14	0.14
TiAlN	0.18	0.18
Ti ₃ N ₄	0.20	0.23
Non-coating (S50C)	0.30	0.30

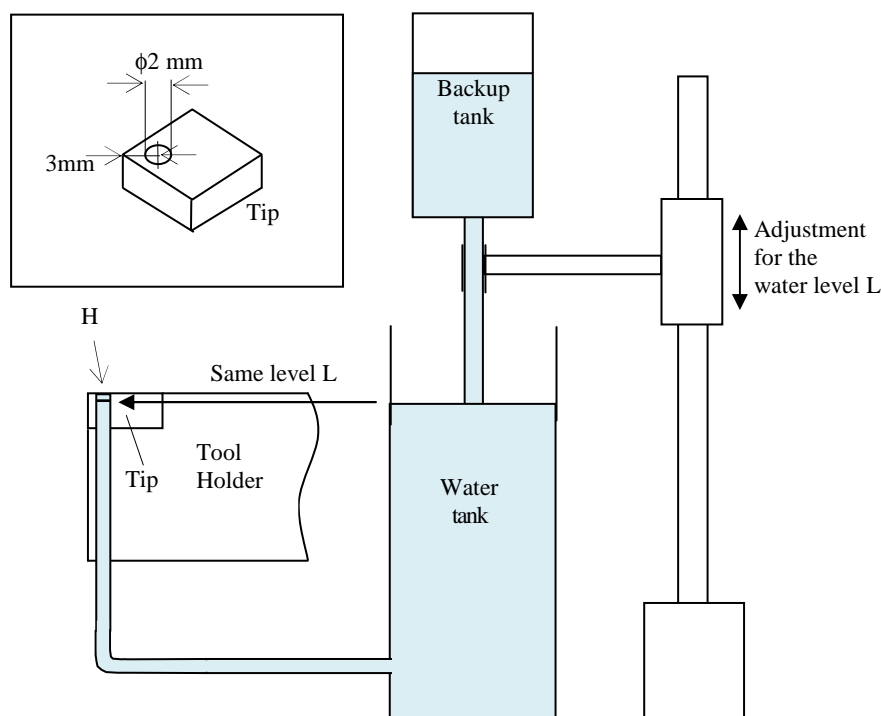

Fig. 6. Schematic view of the system for supplying water

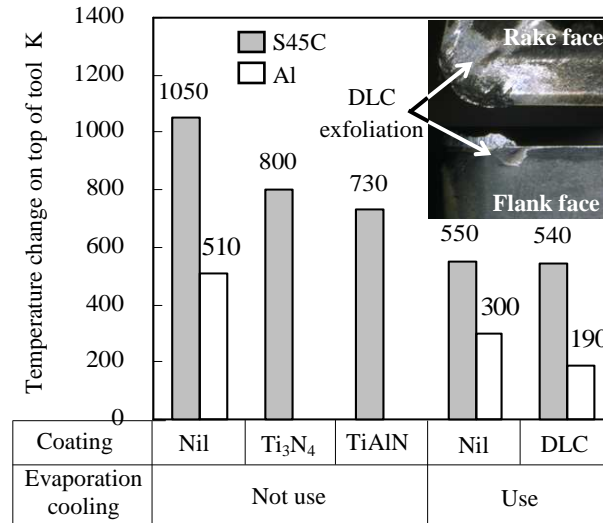

Fig. 7. The temperature change on tool tip and coating materials

Regarding the cutting of S45C, the effectiveness for reducing of temperature rise between two cases of DLC coated and uncoated tool with supplying cooling water is not much difference. This is due to the loss of DLC coating under high temperature and pressure. The condition of DLC coating after experiment is shown in Fig. 7. It is also confirmed that, during cutting of aluminium with the most severe cutting condition, DLC was not lost. At that time, the tool tip temperature rise is reduced about 60% compared with an uncoated tool. In the case of without DLC coating, the tool tip temperature is reduced about 40% when using cooling water compared with dry cutting. Thus, the effectiveness of DLC coating for reducing temperature rise can be considered to be about 20%.

4. CONSIDRATION FOR RELIEVING OF THERMAL EFFECT ON THE TOOL

In this section, the effectiveness of coating layer using as thermal insulator and selection of tool material for the relieving of thermal effect on the tool will be considered.

4.1. THE EFFECT OF THE THERMAL INSULATION COATING

Here, the cutting heat entering into the tool will be retarded by coating with Ti₃N₄ which has low thermal conductivity (19 W/mK).

The experiment is done by using same apparatus and cutting condition with work piece of S45C. The thickness of Ti₃N₄ coating are 3.0, 4.0, 5.0, μm. The extrapolation of the tool tip temperature is done with same method as before. The relation between thickness of Ti₃N₄ coating and tool tip temperature rise is shown in Fig. 8. There is no effectiveness

of thermal insulation when the coating layer is very thin. When the coating thickness of Ti_3N_4 exceeds $5.0 \mu m$, it grows needle shape structure and the hardness also becomes lower. Thus, it is difficult to use Ti_3N_4 coating exceeding this thickness as thermal insulation material.

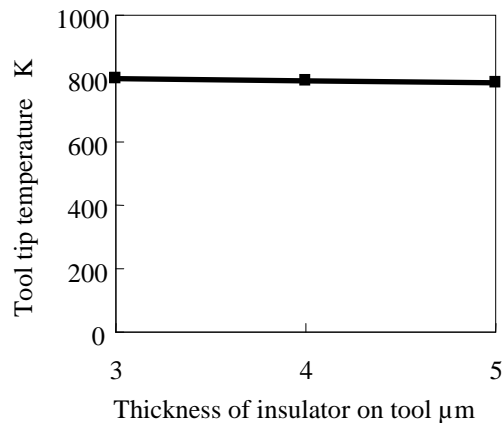

Fig. 8. Relationship between tool tip temperature and thickness of insulator on the tool

4.2. THE DIFFERENCE IN THERMAL EFFECT DEPENDING ON TOOL MATERIAL

Here, the characteristic properties of various cutting tool materials will be considered. In this experiment, two kinds of carbide tools (different thermal conductivities), cermets tool and ceramics tool of 4 kinds in total are used. The same experimental apparatus and cutting condition as before and work-piece is S45C. The extrapolation of tool tip temperature is done using FEM as before. The tool tip temperature results for each tool material are shown in Fig. 9. Only the cermets tool shows high temperature and the others show almost the same level. Comparing with the allowable temperature limit [2],[5] of each kind of tool, only ceramic does not exceed the limit temperature. These tool material types have different mechanical and thermal properties as shown in the first half of Table 4. The results depend on these characteristics properties. Differences can be considered from the step of cutting heat generation to the step till the thermal effect reach to the tool as follow. (1) Different frictional coefficient of tool materials cause differences in frictional generated heat amount, (2) Difference in thermal conductivity of tool materials cause differences in the amount of heat flowing to the tool, (3) Difference in temperature conductivity of tool materials cause differences in tool tip temperature, (4) Difference in melting point of tool materials cause differences in thermal softening factor K_T (Fig. 1.), (5) The difference in hardness of tool material at room temperature affects the hardness of the tool during cutting.

Before the experiment, simple calculations can be done for steps (1) and (2) by using cutting theory [8] or FEM analysis, for step (3) by using FEM thermal analysis, for step (4) by using the equation in Fig. 1. For (5) the tool hardness during cutting can be obtained by multiplying of thermal softening factor from (4) and tool hardness at room temperature. The second half of Table 4 shows the amount of heat flow to the cutting tool

(the values used in FEM thermal analysis for extrapolation of tool tip temperature results shown in Fig. 9.), tool tip temperatures obtained by extrapolation of the experimental results, thermal softening factors at that temperatures and tool hardness during cutting.

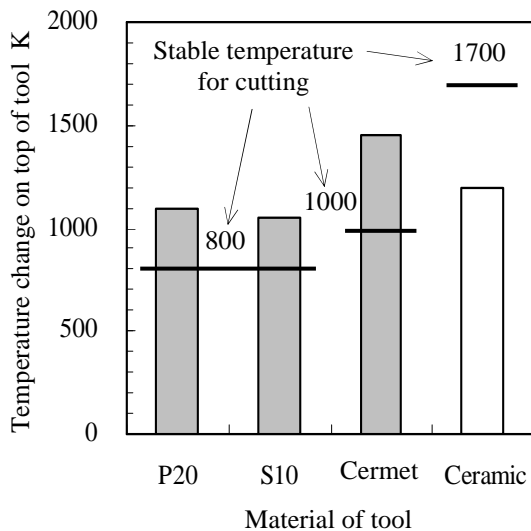

Fig. 9. Relationship between temperature change on the tip of tool and material of tool

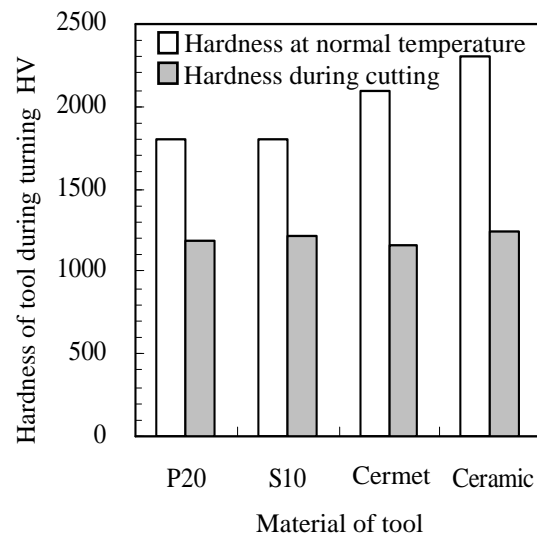

Fig. 10. Relationship between hardness of tool and material of tool during turning

The hardness of each tool material at room temperature and during cutting is shown in Fig. 10. The hardness values of tool materials during cutting become almost the same, although these are different at room temperature. From the results, it is known that ceramics are favorable tool materials from the thermal point of view. Moreover, if the temperature of tool tip is maintained under allowable temperature limit, carbide and cermet tools are also applicable.

5. EVALUATION FOR PRACTICAL APPLICABILITY

Based on the results of previous sections, the experiment for evaluation of practical applicability of tools is taken by using the tools with greatest resistance to the effect of cutting heat.

The same experimental apparatus and cutting condition as in Fig. 2, and Table 1 with work piece of S45C and aluminum are used in the experiment. Rake angle of tool is selected 15° and carbide cutting tools (S10) coated with TiAlN and DLC are used. The result of tool life for cutting S45C is shown in Fig. 11. TiAlN coated tool life is quite longer than without coating. It is known that the coefficient of friction on the rake face is reduced and the generation of cutting heat is also well suppressed. Thus TiAlN have enough hardness under high temperature and pressure of cutting and this enables the coating life longer.

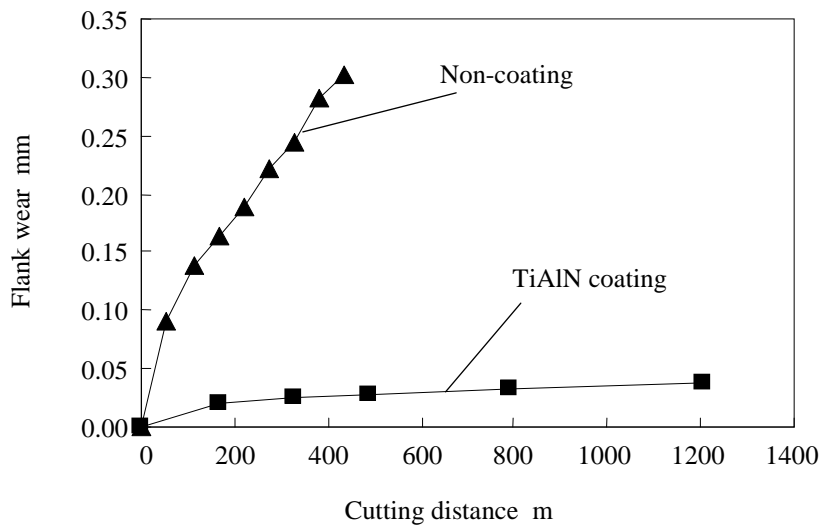

Fig. 11. Result of tool life in cutting S45C

Fig. 12(a) shows the chip welding of aluminum on the tool while cutting with carbide tool without coating. Fig. 12(b) shows the excellent condition of cutting aluminum with the tool coated with DLC. This is due to the effectiveness of DLC coating on the reducing of temperature rise, and hence the lower tool tip temperature and no chip welding on the tool. Even though the proposal with the combination of DLC coating and the cooling water mechanism is not applicable for cutting of S45C, it is useful in cutting of aluminum. The technology for improving hardness of coating is still needed to make applicable of DLC in cutting of the materials other than aluminum.

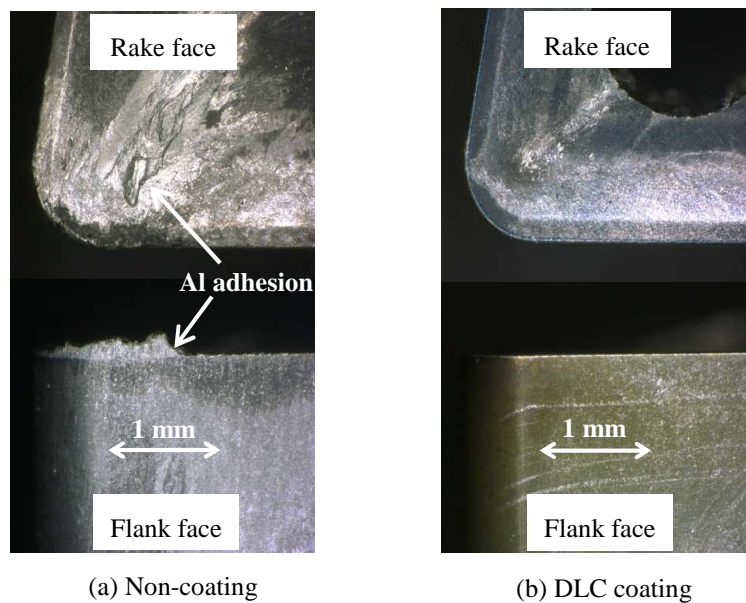

Fig. 12. Photograph of carbide tool in cutting Al

6. CONCLUSION

In this research, the tool technology for reducing cutting heat generation and its influences are investigated and evaluated. It is concluded that; (1) The cutting heat generation can be reduced by optimizing rake angle and application of coatings with solid lubricants on tool surface. (2) In the selection of tool material for excellent resistance to cutting heat, it is necessary to consider not only the cutting temperature but also the hardness of tool during cutting. (3) The tool life with TiAlN coating is much longer compared with tool life without coating.

REFERENCES

- [1] CHILDS T.H.C., 2006, *Friction modelling in metal cutting, wear*, 260/3, 310-318.
- [2] HIROSAKI K., FUJII K., SAKAYA K., 1999, *Adaptive controlled machining of titanium alloy- decision of cutting condition under constraint of cutting temperature*, Report of the Industrial Research Institute of Ishikawa, 48, 9-14.
- [3] JOHNSON G. R., COOK W.H., 1983, *A constitutive model and data for metals subjected to large strains, High Strain Rates and High Temperature*, Proc. 7th Int. Symp. on Ballistic, The Hague, 541-547.
- [4] LOEWEN E.G, SHAW M.C., 1954, *Transaction of The American Society of Mechanical Engineers*, 76/2, 217-231.
- [5] SENTOKU E., FUJIMURA Y., KAWABATA H., 1986, *A study on the crater wear of cermet tools- wear mechanism at high speed cutting*, Transactions of the Japan Society for Precision Engineering, 52/, 93-99.
- [6] TANABE I., BINH H. T., SUGAI H., INOUE M., 2007, *Cutting with heating of work piece and cooling of tool regarding cemented mould and die*, Transactions of the Japan Society of Mechanical Engineers, Series C, 73/727, 885-890.
- [7] TAIRA T., TANABE I., KYUSOJIN A. MINAKI K., 2004, *Coefficient of friction about small sliding surface using photo-fabrication (influence of the sliding surface on the friction and the design using neural network)*, Transaction of the Japan Society of Mechanical Engineers, Series C,70/690, 223-229.
- [8] TAKEYAMA H., 1980, *Cutting process*, Maruzen Co., ltd, 35-47.