

ROLE OF SUSTAINABLE QUALITY MANAGEMENT TO PROMOTE EMPLOYEE PERFORMANCE AND CUSTOMER SATISFACTION AMONG EDUCATIONAL INSTITUTIONS

Jasin M., Hakimah Y., Rudianto, Faisal A. *

Abstract: Sustainable quality management among educational institutions is most important to produce quality education for the customers. It is one of the important elements to satisfy the customers. However, Indonesian educational sector requires significant reforms to enhance the education quality by enhancing the sustainable quality management. Therefore, objective of this study is to promote customer satisfaction with the help of sustainable quality management. Sustainable quality management include; critical success factors (CSFs) and national quality awards (NQAs). Survey was performed to collect the data from university employees. In survey, a questionnaire based on 5-point Likert scale was used. Findings of the study highlighted that sustainable quality management has crucial role in employee performance and customer satisfaction. Critical success factors (CSFs) and national quality awards (NQAs) has positive effect to improve the employee performance and boost the customer satisfaction level. Additionally, employee performance playing a mediating role between sustainable quality management and customer satisfaction.

Key words: sustainable quality management, employee performance, customer satisfaction, national quality awards

DOI: 10.17512/pjms.2019.20.1.19

Article history:

Received August 29, 2019; Revised September 18, 2019; Accepted October 9, 2019

Introduction

Educational institutions have pivotal role in nation development as better education system play a significant role to produce quality students, employees and workers which contributes to the economic development. In this prospective, educational institution requires achieving higher education quality (Latif et al., 2019; Kurowska-Pysz et al., 2018). However, in most of the developing countries like Indonesia, the quality management is poor among the universities. Poor quality shows negative effect on customer satisfaction.

Consequently, objective of this study is to promote customer satisfaction with the help of sustainable quality management. Sustainable quality management include;

* **Mochammad Jasin**, Faculty of Economics and Business, Universitas Islam Negeri Syarif Hidayatullah, Jakarta, Indonesia; **Yusro Hakimah**, Faculty of Electrical Engineering, Universitas Tridianti Palembang, Palembang, Indonesia; **Rudianto**, Faculty of Economics, Institute of Business and Multimedia ASMI, Jakarta, Indonesia; **Ahmad Faisal** Faculty of Economics, University of Dirgantara Marsekal Suryadarma, Jakarta, Indonesia

✉ corresponding author: moch.jasin@uinjkt.co.id

critical success factors (CSFs) and national quality awards (NQAs). The relationship between sustainable quality management, employee performance and customer satisfaction is highlighted in Figure 1. The sub-objectives of the study are as follows:

1. To check the influence of critical success factors (CSFs) on employee performance and customer satisfaction.
2. To check the influence of national quality awards (NQAs) on employee performance and customer satisfaction.
3. To check the mediating role of employee performance.

The current study contributed theoretically by exploring the role of sustainable quality management in customer satisfaction. Particularly this is one of the pioneer studies which examined the role of sustainable quality management in customer satisfaction among educational institutions. This is also a pioneer study which examined the mediating role of employee performance between sustainable quality management and customer satisfaction. Thus, this study significantly contributed to the knowledge related to the quality management among educational institutions of Indonesia. Theoretical framework of the study showing the relationship between sustainable quality management, employee performance and customer satisfaction in given below Figure 1.

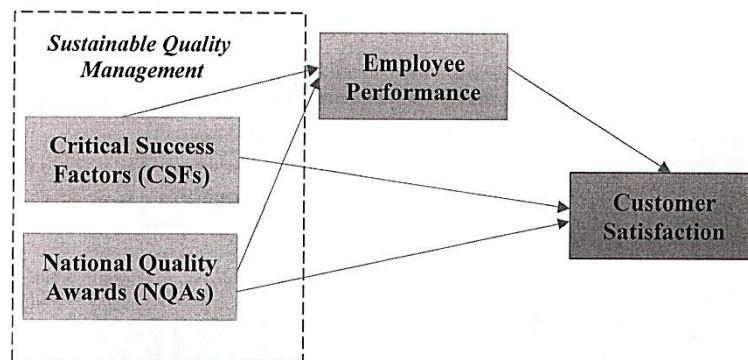

Figure 1: Theoretical Framework

Literature Review

In general, there is no formulation of a theory associated with quality management or any final short list of practices related to it (Lawler III, 1994; Tari, 2005). The extensive review on literature shows that there is not a clear consensus about what are the real factors of the quality management and the best way to digest the quality management into factors or elements (Samson and Terziovski, 1999). Quality management categorised by principles allow a universal road map and enforced by a variety of practices and techniques. Consequently, in order to study quality management, previous investigations focused on recognizing factors that linked with quality management implementation. A number of scholars attempted to

adopt these national quality awards (NQAs) such as MBNQA and EFQM framework to develop their instrument to measure quality management operational model in their studies. Quality management can be applied as an operational framework for employee performance as well as customer satisfaction (Vlasov et al., 2018).

First, the criteria involved in the NQAs reflect all main factors of quality management. Besides, to be in-line with Kartha (2004), Curkovic et al. (2000) also claimed that NQAs framework does capture the concept of quality. These criteria establish a framework for integrating quality in any organization (Arribas et al., 2019). Second, based on the above-mentioned reflection, most of the countries around the world seeking to establish NQA as their basis framework. The NQAs of countries are based on various quality management activities (Paudel and Devkota, 2018). Third, the critical success factors (CSFs) form a framework for business quality in any firm; manufacturing as well as service, large or small. Besides the criteria for the CSFs are updated yearly, it also covers a variety of industries including education and scholars do agree that the MBNQA present best framework for quality management. Likewise, CSFs includes one criterion of organizational performance (result), and various practices of related to the quality. Critical success factors (CSFs) are vital components for manager or organization for assuring the success of any quality management implementation. These factors have positive effect on employee performance and customer satisfaction. Furthermore, by synthesizing the ideas of pioneer quality scholars developed and tested an instrument namely critical success factors (CSFs) in quality management. Furthermore, by using the CSFs, a number of quality management scholars (Joseph et al., 1999; Sánchez-Rodríguez and Martínez-Lorente, 2004) empirically developed and examined the association between quality management based on their own research setting. Earlier studies established eight CSFs (top management leadership, quality of various department, various activities of training, different product design, practices related to the supplier quality management, activities related to the process management, data quality reporting activities, and employee relations), whilst Flynn et al. (1994) found eleven (leadership quality, reward related quality, quality in process control, quality of feedback, cleanliness as well as organization, quality of inter-functional design, quality related to the new product, selection for teamwork potential, quality of teamwork, quality related to the supplier relationship, and quality with customer interaction). In other setting, Ahire et al. (1996) suggested twelve (quality of top management, quality of supplier, quality of customer focus, quality of usage, quality of benchmarking, quality of internal data usage, quality of employee involvement, quality of employee training, quality of design management, quality of employee authorisation, and various elements of product quality). Furthermore, Sánchez-Rodríguez and Martínez-Lorente (2004) proposed eight CSFs. In brief, there is inconclusive agreement among the scholars about the numbers or specific CSFs that should be applied in organizations either manufacturing or service setting.

All these factors have significant relationship with employee performance and customer satisfaction.

H1. *Critical success factors have positive effect on employee performance.*

H2. *Critical success factors have positive effect on customer satisfaction.*

Subsequently, organizations developed their quality management framework by following the evaluation criteria for national quality awards (NQAs) (Sila and Ebrahimpour, 2002). These NQAs has positive role to promote customer satisfaction and employee performance. Commonly, a number of QMPs scholars are using these NQAs criteria as a framework for their studies. In brief, Bou-Llusar et al. (2009) revealed that the well-demonstrated NQAs are Deming Prize (Japan), Malcolm Baldrige National Quality Award (MBNQA) (U.S), and the European Foundation for Quality Management (EFQM) (Europe). Furthermore, Chuan and Soon (2000) carried a framework based on a comparison to the seventeen NQAs that have been applied around the world. In this framework, eleven major criteria identified in their analysis. These factors are related to the leadership, various strategies and planning, management of people, analysing the information, decision making on resources, quality systems as well as procedures, market environment focus, satisfaction of people, effect on society, supplier relationship, and results. Talwar (2011) analysed the framework and criterion weighting of twenty NQAs (Figure 2).

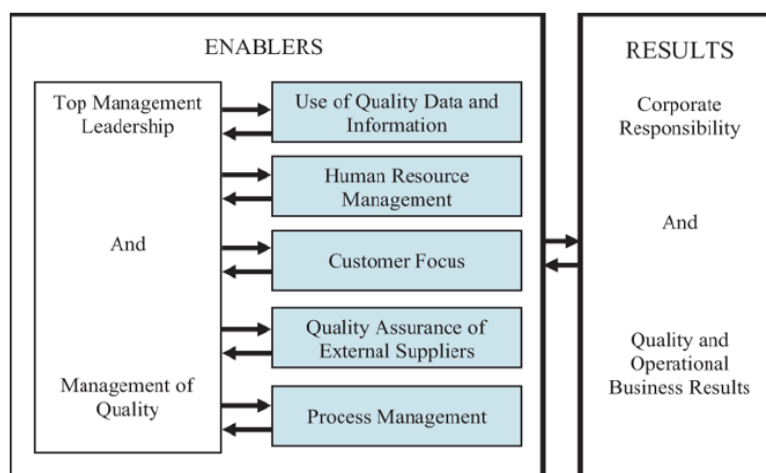

Figure 2: Framework of Quality Award

It is identified nine generic criteria: leadership criteria, strategic planning criteria, people criteria, supplier/partner criteria, customer criteria, knowledge as well as data management criteria, procedures criteria, society criteria, and business outcomes criteria. To sum up, studies provide the information that the most commonly used NQAs are MBNQA, EFQM and Deming Prize. These NQAs

effect positively on employee performance which ultimately increases the customer satisfaction that is mentioned in Figure 2.

H3. Employee performance has positive effect on customer satisfaction

H4. National quality award has positive effect on employee performance.

H5. National quality award has positive effect on customer satisfaction.

H6. Employee performance mediates the relationship between critical success factors and customer satisfaction.

H7. Employee performance mediates the relationship between national quality awards and customer satisfaction.

Research Methodology

This study preferred to use quantitative research method. In quantitative research method, a questionnaire was used for data collection. However, by using a questionnaire, data were collected only one point of time; therefore, cross-sectional research design was used in the current study. Employees of the Indonesian universities were selected as the respondents of the current study.

Population and Sampling

Population of the study is based on the universities of Indonesia. Therefore, data were collected by using questionnaire from the universities of Indonesia. Employees of the universities were selected as the respondents of the study. Only those employees were selected having both duties related to the teaching and administration. For questionnaire distribution, area cluster sampling was preferred because it is most appropriate technique to cover the wide area (Altaf et al., 2019; Ul-Hameed et al., 2018). Total 382 questionnaires were used for data collection. The sample size was extracted based on the size of population. In Indonesian universities, number of employees is above 100,000. According to the Krejcie and Morgan (1970), if the population is above 100,000 the sample size must be 382 or above. From total distributed questionnaires, 190 were returned and used for data analysis.

Data Analysis and Findings

Structural equation modelling (SEM) is applied in this study for data analysis. Partial least square (PLS) was used to run SEM. This study followed various steps of PLS-SEM from Hameed and Naveed (2019). According to prior studies, for the achievement of internal consistency, factor loadings must be above 0.5. Figure 3 and Table 1 shows the factor loading which is above 0.5. Moreover, composite reliability (CR) and average variance extracted (AVE) is presented in Table 3 which is above 0.7 and 0.5 respectively (Hair et al., 2017). These values also confirmed the convergent validity.

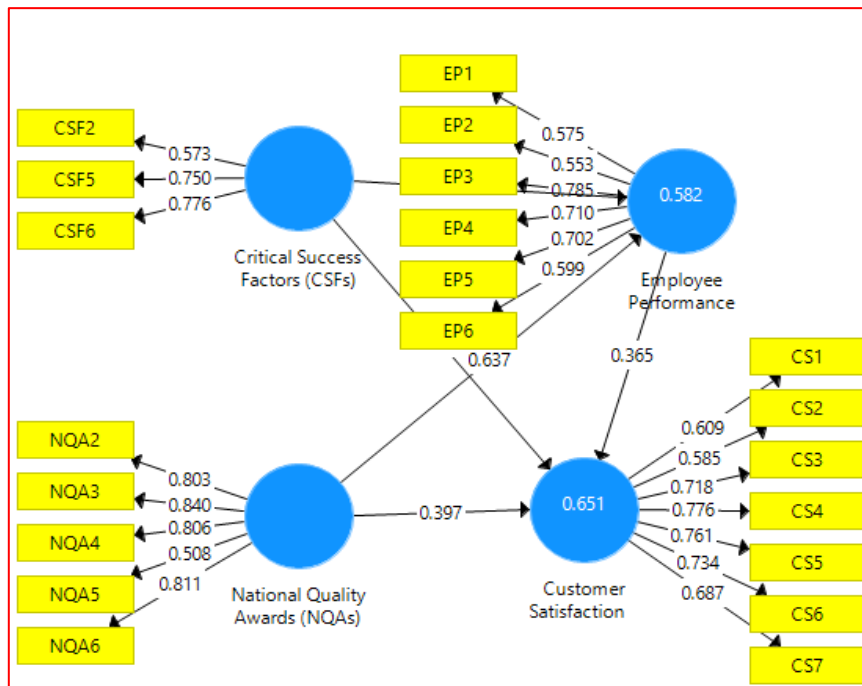

Figure 3: Measurement Model

Table 1: Reliability and Validity

	Alpha	rho_A	CR	(AVE)
Critical Success Factors (CSFs)	0.785	0.703	0.745	0.598
Customer Satisfaction (CS)	0.823	0.829	0.869	0.589
Employee Performance (EP)	0.736	0.754	0.819	0.535
National Quality Awards (NQAs)	0.811	0.829	0.872	0.583

It is confirmed that CR and AVE values are above the minimum threshold level which confirms the reliability and convergent validity. After that discriminant validity was examined through cross-loadings. Structural model with the help of PLS bootstrapping was performed to get the results for hypotheses. Total seven hypotheses were proposed in the current study. All the hypotheses having t-value equal to or above 1.96 were considered as supported. Figure 4 shows the structural model and results are highlighted in Table 2.

Table 2: Direct Effect Results

	β	M	SD	T Statistics	P Values
CSFs -> CS	0.141	0.142	0.063	2.231	0.026
CSFs -> EP	0.19	0.192	0.057	3.312	0.001
EP -> CS	0.365	0.365	0.082	4.43	0
NQAs -> CS	0.397	0.4	0.074	5.38	0
NQAs -> EP	0.637	0.638	0.05	12.68	0

It is found that all the direct hypotheses H1, H2, H3, H4 and H5 have t-value above 1.96. Thus, all the direct hypotheses are supported.

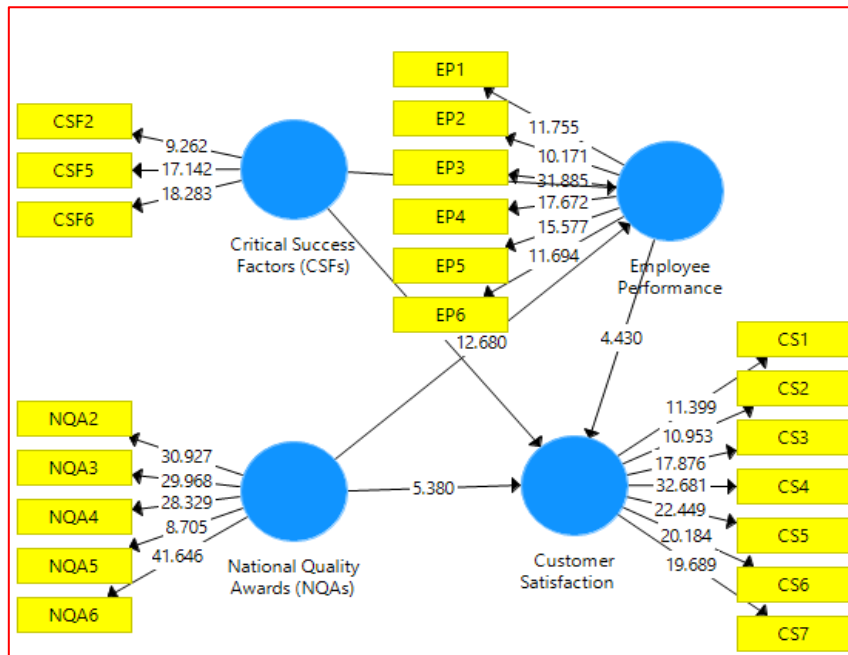

Figure 4: Structural Model

Mediation effect of employee performance is presented in Table 3. Two mediation hypotheses were tested. It is clear from Table 6 that both mediation hypotheses have t-value above 1.96. Hence, these hypotheses (H6, H7) are supported. Additionally, r-square (R^2) value for customer satisfaction is 0.651 which is substantial (Chin, 1998). Therefore, critical success factors (CSFs), national quality awards (NQAs) and employee performances are expected to bring 65.1% change in customer satisfaction. Results of the study proved that critical success factors (CSFs) and national quality awards (NQAs) has positive effect on employee's performance and customer satisfaction. Moreover, employee performance has positive effect on customer satisfaction. The results are matched with results of Al Shobaki and Naser (2017) and Karatepe (2013) who also found mediation impact of employee performance among the CDF and customer satisfaction.

Table 3: In-Direct Effect Results

	β	M	SD	T Statistics	P Values
CSFs -> EP -> CS	0.069	0.069	0.024	2.884	0.004
NQAs -> EP -> CS	0.232	0.234	0.059	3.907	0

Conclusion

Purpose of this study was to promote customer satisfaction with the help of sustainable quality management. Sustainable quality management include; critical success factors (CSFs) and national quality awards (NQAs). Additionally, the role of employee performance was also examined. Findings of the study highlighted that sustainable quality management has crucial role in employee performance and customer satisfaction. Improvement in quality management among universities increases the employee performance and customer satisfaction. It is found that critical success factors (CSFs) and national quality awards (NQAs) has positive effect on employee performance. Ultimately increase in employee performance increases the customer satisfaction. Critical success factors (CSFs) and national quality awards (NQAs) has positive effect to improve the employee performance and boost the customer satisfaction level. Additionally, employee performance as a mediating variable reflect the positive effect of critical success factors (CSFs) and national quality awards (NQAs) on customer satisfaction. Therefore, Indonesian universities should insure better quality management strategies to enhance the customer satisfaction.

The findings suggested to the regulation making authorities that they develop the policies about the CFS and NQA that enhance the customer satisfaction also focus on the employee performance that also enhance the customer satisfaction. In addition, this study has some limitations that are the directions of prospective researchers. This study take two factors to predict the customer satisfaction and further studies may add more factors in their analysis. Moreover, current study take employee performance as mediation and further study may add moderation in the model.

References

- Ahire, S.L., Golhar, D.Y., & Waller, M.A. (1996). Development and validation of TQM implementation constructs. *Decision sciences*, 27(1), 23-56.
- Al Shobaki, M.J., Naser, S.S.A. (2017). The Role of the Practice of Excellence Strategies in Education to Achieve Sustainable Competitive Advantage to Institutions of Higher Education-Faculty of Engineering and Information Technology at Al-Azhar University in Gaza a Model.
- Arribas, I., Espinós-Vañó, M.D., García, F., & Tamosiuniene, R. (2019). Negative screening and sustainable portfolio diversification.
- Bou-Llusar, J.C., Escrig-Tena, A.B., Roca-Puig, V., & Beltrán-Martín, I. (2009). An empirical assessment of the EFQM Excellence Model: Evaluation as a TQM framework relative to the MBNQA Model. *Journal of operations management*, 27(1), 1-22.
- Chin, W.W. (1998). The partial least squares approach to structural equation modeling. *Modern methods for business research*, 295(2), 295-336.
- Chuan, T.K., Soon, L.C. (2000). A detailed trends analysis of national quality awards world-wide. *Total quality management*, 11(8), 1065-1080.

- Flynn, B.B., Schroeder, R.G., & Sakakibara, S. (1994). A framework for quality management research and an associated measurement instrument. *Journal of operations management*, 11(4), 339-366.
- Hameed, W., Naveed, F. (2019). Coopetition-Based Open-Innovation and Innovation Performance: Role of Trust and Dependency Evidence from Malaysian High-Tech SMEs. *Pakistan Journal of Commerce and Social Sciences*, 13(1), 209-230.
- Karatepe, O.M. (2013). High-performance work practices and hotel employee performance: The mediation of work engagement. *International Journal of Hospitality Management*, 32, 132-140.
- Kartha, C.P. (2004). A comparison of ISO 9000: 2000 quality system standards, QS9000, ISO/TS 16949 and Baldrige criteria. *The TQM magazine*, 16(5), 331-340.
- Krejcie, R.V., Morgan, D.W. (1970). Determining sample size for research activities. *Educational and Psychological Measurement*, 30(3), 607-610.
- Kurowska-Pysz, J., Wróblewski, Ł., & Szczepańska-Woszczyzna, K. (2018). *Identification and assessment of barriers to the development of cross-border cooperation*, Proceedings of the 31st International Business Information Management Association Conference, IBIMA 2018: Innovation Management and Education Excellence through Vision 2020, 3317-3327.
- Paudel, U.R., Devkota, N. (2018). Socio-Economic Influences on Small Business Performance in Nepal-India Open Border: Evidence from Cross-Sectional Analysis. *Economics & Sociology*, 11(4), 11.
- Samson, D., Terziovski, M. (1999). The relationship between total quality management practices and operational performance. *Journal of operations management*, 17(4), 393-409.
- Sila, I., Ebrahimpour, M. (2002). An investigation of the total quality management survey based research published between 1989 and 2000: A literature review. *International Journal of Quality & Reliability Management*, 19(7), 902-970.
- Talwar, B. (2011). Comparative study of framework, criteria and criterion weighting of excellence models. *Measuring Business Excellence*, 15(1), 49-65.
- Vlasov, A.I., Grigoriev, P.V., Krivoshein, A.I., Shakhnov, V.A., Filin, S.S., & Migalin, V.S. (2018). Smart management of technologies: predictive maintenance of industrial equipment using wireless sensor networks. *Entrepreneurship and Sustainability Issues*, 6(2), 489-502.

ROLA ZRÓWNOWAŻONEGO ZARZĄDZANIA JAKOŚCIĄ W CELU PROMOWANIA WYNIKÓW PRACOWNIKÓW I SATYSFAKCJI KLIENTA WŚRÓD INSTYTUCJI EDUKACYJNYCH

Streszczenie: Zrównoważone zarządzanie jakością wśród instytucji edukacyjnych jest najważniejsze dla zapewnienia wysokiej jakości edukacji dla klientów. Jest to jeden z ważnych elementów satysfakcji klientów. Jednak indonezyjski sektor edukacji wymaga znacznych reform w celu poprawy jakości edukacji poprzez usprawnienie zrównoważonego zarządzania jakością. Dlatego celem tego artykułu jest promowanie zadowolenia klientów za pomocą zrównoważonego zarządzania jakością. Zrównoważone zarządzanie jakością obejmuje; krytyczne czynniki sukcesu (CSF) i krajowe nagrody jakości (NQA). Ankieta została przeprowadzona w celu zebrania danych wśród pracowników uczelni. W ankiecie zastosowano kwestionariusz oparty na 5-punktowej skali Likerta. Wyniki badania pokazały, że zrównoważone zarządzanie jakością odgrywa kluczową rolę w wydajności

pracowników i zadowoleniu klientów. Krytyczne czynniki sukcesu (CSF) i krajowe nagrody jakości (NQA) mają pozytywny wpływ na poprawę wydajności pracowników i wzrost poziomu zadowolenia klientów. Dodatkowo wydajność pracowników odgrywa rolę pośredniczącą między zrównoważonym zarządzaniem jakością a satysfakcją klienta.

Słowa kluczowe: zrównoważone zarządzanie jakością, wydajność pracowników, satysfakcja klienta, krajowe nagrody jakości

可持续的质量管理在提高教育机构中员工的绩效和客户满意度方面的作用

摘要: 教育机构之间的可持续质量管理对于为客户提供优质教育至关重要。这是满足客户需求的重要因素之一。但是, 印度尼西亚的教育部门需要进行重大改革, 以通过加强可持续的质量管理来提高教育质量。因此, 本研究的目的是在可持续质量管理的帮助下提高客户满意度。可持续质量管理包括; 关键成功因素 (CSF) 和国家质量奖 (NQA)。进行了调查以收集大学员工的数据。在调查中, 使用了基于5点李克特量表的问卷。该研究的结果强调, 可持续的质量管理对员工绩效和客户满意度至关重要。关键成功因素 (CSF) 和国家质量奖 (NQA) 对提高员工绩效和提高客户满意度有积极作用。此外, 员工绩效在可持续质量管理和客户满意度之间起着中介作用。

关键词: 可持续质量管理, 员工绩效, 客户满意度, 国家质量奖。