

Performance Evaluation of Tractor Engine Using Waste Vegetable Oil Biodiesel for Agricultural Purpose

Munaf D.F. Al-Aseebee¹, Alaa M. Akol¹, Ahmed Samir Naje^{1*}

¹ College of Engineering, AL-Qasim Green University, 51031, Babylon, Iraq

* Corresponding author's e-mail: ahmednamesamir@yahoo.com

ABSTRACT

Restaurants and food processors that frequently utilize frying oils can provide waste vegetable oil for free or for a small price. To compare the use of OAME to fossil diesel on the performance of the 67 kW Kubota tractor diesel engine, the methyl ester of oleic acid methyl ester (OAME) biodiesel was created from used vegetable oil using the transesterification process. The OAME gasoline was used straight up. The engine's performance parameters and key indications, such as the indicated torque, brake torque, indicated power, fuel consumption of the braking force brake (BSFC), and exhaust gas emissions, were determined. The choice of a certain biofuel made from a specific source is primarily based on its economic viability and availability where it is utilized.

Keywords: biodiesel, fuels, oil, oleic acid methyl ester.

INTRODUCTION

A substitute for diesel fuel that can be used in diesel engines is biodiesel. Due to the impending end of oil and the volatility of its costs, scientists are searching for sustainable alternatives to oil (Mahalingam et al., 2018). Testing was done using a two-cylinder, naturally aspirated diesel engine at a constant speed by (Devarajan et al., 2018) and it was discovered that improving the ignition characteristics was achieved by incorporating Ag₂O nanoparticles into palm oil mill effluent (POME). In order to conduct the experiments, four different types of clear diesel and biodiesel were directly injected into the four cylinders of a diesel engine. According to the test created by Zhang et al. (2018), the kinematic viscosity and the ignition delay time (IDT) of the biodiesel fuel were both crucial factors in the burning process. In contrast to the FE blend, Roy et al. (2021) observed, that diesel smoke obtains the maximum NO_x values with the existence of a minimum quantity. When compared to diesel, blends have much lower smoke and hydrocarbon emissions. Burning experiments showed that the

blend burns longer than diesel fuel due to the increasing amount of unsaturated fatty acids. According to Shepel et al. (2021), the use of animal fats and fish oil is regarded as the raw material for the synthesis of biodiesel. Because it minimizes exhaust fumes, beef tallow biodiesel is the most environmentally friendly biodiesel in terms of renewable energy. In fact, it is more energy efficient than fossil fuels and has a higher value than the biodiesel counterpart. When comparing it to vegetable oil and fried cooking oil in terms of economy and productivity Mata et al. (2014) took raw ingredients into account. The authors demonstrated that biodiesel made from waste and animal fats has a significant impact on reducing environmental pollution and advancing toward a significant renewed expansion. To obtain and characterize the biodiesel Srinivasan & Jambulingam (2018) conducted research on animal substances such pig fat and chicken skin. After that, different volume amounts of petroleum diesel are combined with the created biodiesel. As per ASTM standards, various thermochemical properties were evaluated. The study's findings showed that the biodiesel

mixture's qualities were well within the parameters allowed by ASTM standards. The effects of combining biodiesel and fish oil on spraying, combustion, application, and extrusion qualities were thoroughly understood by Ravikumar et al. (2021). Therefore, combining fish oil biodiesel with regular diesel fuel can be used effectively in diesel engines without requiring significant engine modifications (Nguyen et al., 2020). The performance of a Kubota 67 kW tractor diesel engine was compared with that of mineral diesel and three different biodiesel samples made from used frying oil, palm oil, and castor oil. Fish oil biodiesel was mixed with produced petroleum diesel in a variety of ratios, including 0%, 10%, 20%, 30%, 40%, and 50% biodiesel. On a single-cylinder common rail diesel motor, the experiment was conducted using both emulations from B0 to B50 and from B0 to B30 (Nguyen et al., 2020). The purpose of this examination is to evaluate the biofuels as diesel of tractor engine that used for agricultural purpose.

MATERIALS AND METHOD

Biofuel production

One of the most significant fuel kinds in the entire planet is biodiesel. It is manufactured from discarded frying oil, algae, vegetable oils in both their edible and inedible forms, animal fats, fish fats, and all kinds of vegetable fats. The transesterification process transforms these oils into biodiesel in all of its forms. In this study, vegetable oil used for frying was converted into biodiesel (Nguyen et al., 2021; Gad et al., 2021; Rajan et al., 2021; Jagadevkumar & Pravin, 2020; Hasan et al., 2021; Al-Aseebee et al., 2021; Liu et al., 2022; Gupta, 2012; Murillo et al., 2007). The oil should first be heated to 80 °C before being allowed to cool to the reaction temperature of 55 °C. It is produced and well mixed 400 ml of methanol alcohol with 13 g of sodium hydroxide. When the oil reaches a temperature of 55 °C, it is measured, and the mixture is poured over it and swirled for an hour before being placed in a separating funnel for two hours. The mixture needs to be cleaned with water that is 70 °C in temperature. The washing procedure is expected to be done multiple times until a pH of 6–7 is attained, with the amount of water being equal to 20% of the amount of fuel.

Experimental set-up

On a Kubota M1-100S-DT 73.6 kW four-cylinder farm tractor, the test was executed practically using a variety of engine speeds, loads, and indirect injection in accordance with the tractor's specifications listed in Table 1. As depicted in figure 1, the engine and gas test dynamic exhaust are intimately associated. The experiment was set up with varied loads that represented the maximum fuel load and the average load capacity of the diesel engine at rotational speeds of 297, 2234, and 2850 rpm. An exhaust gas analyzer meter was used to measure the fuel consumption, torque, power, and exhaust gases.

RESULTS AND DISCUSSION

Biofuel consumption

Figure 2 displays the distribution of brake-specific fuel usage at various engine speeds for both fossil diesel and OAME fuels. For the OAME fuel, the greatest CBSF of 757,833 g·kWh⁻¹ is noted at 2400 rpm. The greatest CBSF value for fossil diesel, measured at 800 rpm, is 549.061 g·kWh⁻¹. The lowest value for fossil diesel is equal to 409.374 g·kWh⁻¹, while the lowest value for OAME fuel is obtained at 1200 rpm of the engine speed. The results indicate that the CBSF of the OAME fuel is higher than that of the fossil diesel fuel at 1600 rpm of the engine speed. This is so because, in comparison

Table 1. Technical specifications of the tractor

Model	Kubota M ₁ -100S-DT
Type of engine	Four stroke, indirect injection, turbocharged, liquid cooled diesel
Engine power (kW)	73.6
Rated Engine speed (rpm)	2600
Compression ratio	21.8:1
Number of cylinders	4-cylinder
Bore (mm)	100
stroke (mm)	120
Technical specifications of the hooked hydraulic brake stationary dynamometer	
Model	NEB600
Serial number	CD6190C5
Range	300 kW at 540 rpm
	600 kW at 1000 rpm
Capacity of torque	4338 N·m

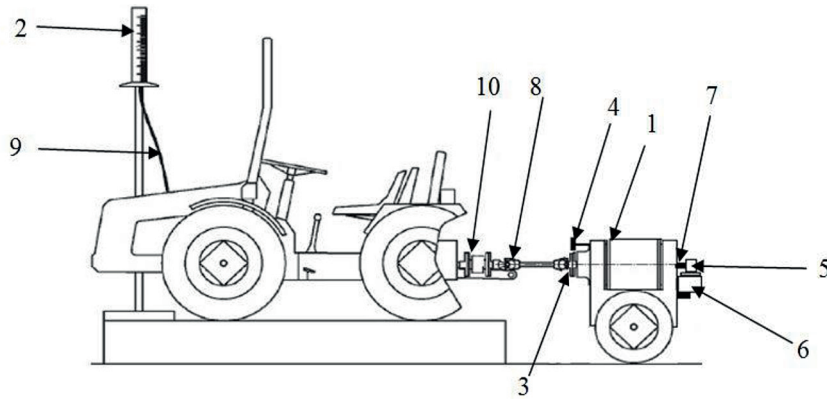

No	Designation	No	Designation
1	Hydraulic brake dynamometer	6	Strain gage load cell
2	Fuel graduated cylinder	7	Rotating drum shaft
3	RPM toothed gear	8	Tractor P.T.O shaft
4	RPM magnetic core	9	Hose to injection pump
5	Torque arm lever	10	Coupling connection

Figure 1. Schematic view of the engine test arrangement

to fossil diesel fuel, it has a lower heating value per unit mass. As a result, the engine needs to be fuelled with additional fuel as it starts to run on OAME fuel.

Emission of CO

Figure 3 displays the CO emissions for fossil diesel and OAME fuels at various engine speeds between 800 and 2800 rpm, shown as a percentage. These data demonstrate that at an engine speed of 800 rpm, fossil diesel fuel emits the maximum percentage of carbon dioxide (CO₂), at a rate of 7.48%. In contrast, OAME fuel emits somewhat less CO, at a rate of 5.448%, than fossil diesel fuel. For the fossil diesel and OAME fuels, the lowest emissions rates of 0.001% and 0.002%, respectively, have been discovered at an engine speed of 2800 rpm. As a result of these findings, it is clear that using OAME biofuel instead of conventional fossil diesel fuel reduces the engine’s CO emissions, making the former fuel a viable replacement in the future.

Emission of CO₂

The rise in CO₂ emissions, the most significant environmental issue facing the globe today, is one of the primary causes of global warming. The impact of using biodiesel on internal combustion engines’ CO₂ emissions is thus something

that is worthwhile to concentrate on. Figure 4 provides an illustration of the variance in CO₂ emissions for OAME and fossil diesel fuels at engine speeds ranging from 800 rpm to 2800 rpm. According to these findings, the normal fossil diesel fuel and the OAME fuel both produce significant levels of CO₂ emissions at 1200 rpm, with the OAME fuel emitting the maximum CO₂ (9.305%) and 8.364%, respectively. For the OAME fuel, the minimal CO₂ emission value of 4.36% was observed at an engine speed of 2800 rpm. Consequently, in the case of ordinary fossil diesel fuel, the minimal CO₂ emission value is 4.945%. These findings can be attributed to the

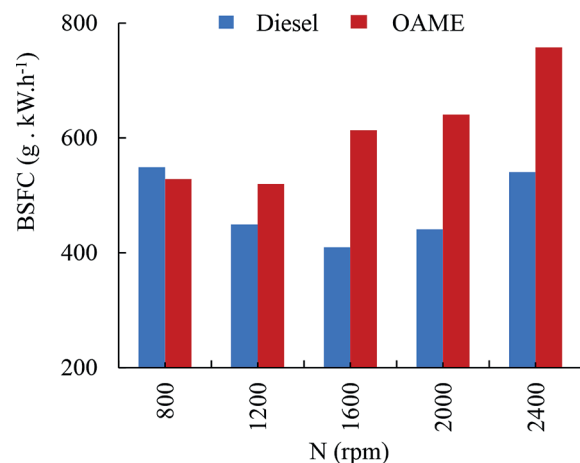

Figure 2. Distribution of the brake specific fuel consumption C_{BSF}

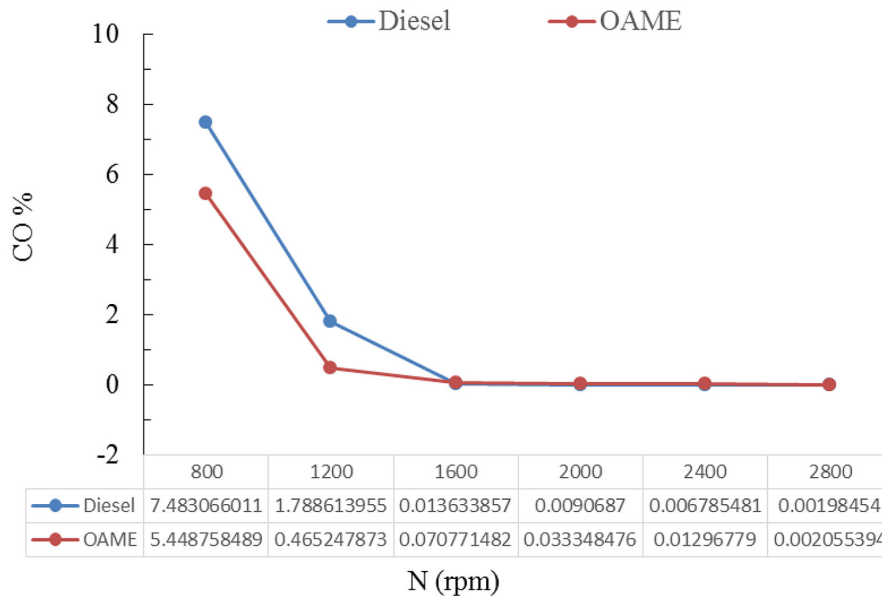

Figure 3. Cycle average of the CO emission

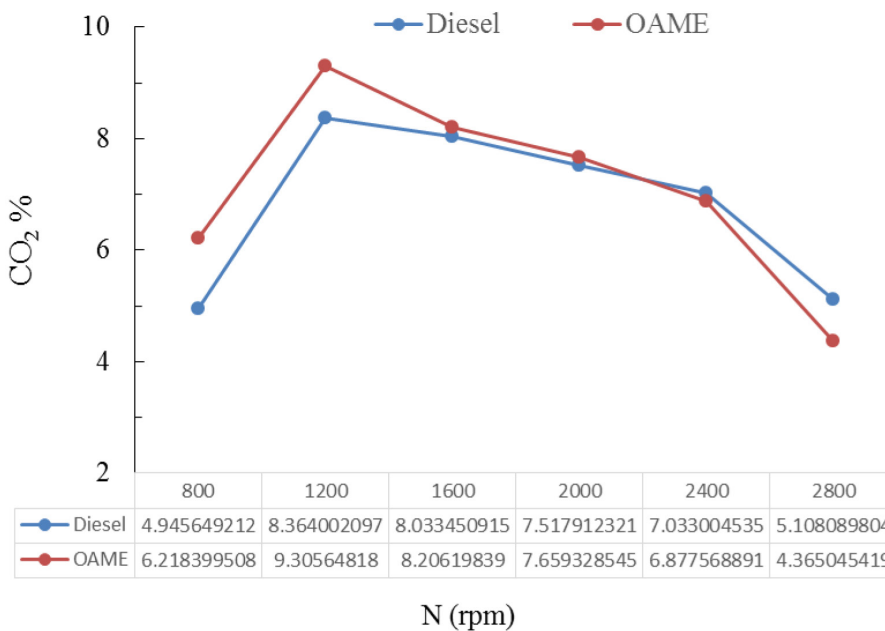

Figure 4. Cycle average of the CO₂ emission

OAME fuel’s high oxygen content, which promotes a more thorough burning.

Emission of O₂

Figure 5 illustrates the change in O₂ emissions for the cases of OAME and fossil diesel fuels at various engine speeds ranging from 800 rpm to 2800 rpm. Comparing the oxygen emission of OAME fuel to that of fossil diesel fuel, it is discovered to be greater. A more thorough combustion of the fuel is produced thanks to the

greater O₂ content in the OAME fuel. More residual oxygen is produced when using OAME fuels than when burning fossil diesel fuel. With an increase in engine speed, these emissions rise. In the case of the OAME fuel, the greatest O₂ emission of 18.342% was discovered at an engine rotational speed of 2800 rpm. The fossil diesel fuel displays a percentage of 17.49% at the same engine speed. At an engine speed of 800 rpm, the OAME fuel reported the lowest emission of 11.40%. The fossil diesel fuel displays a percentage of 11.16% at the same pace.

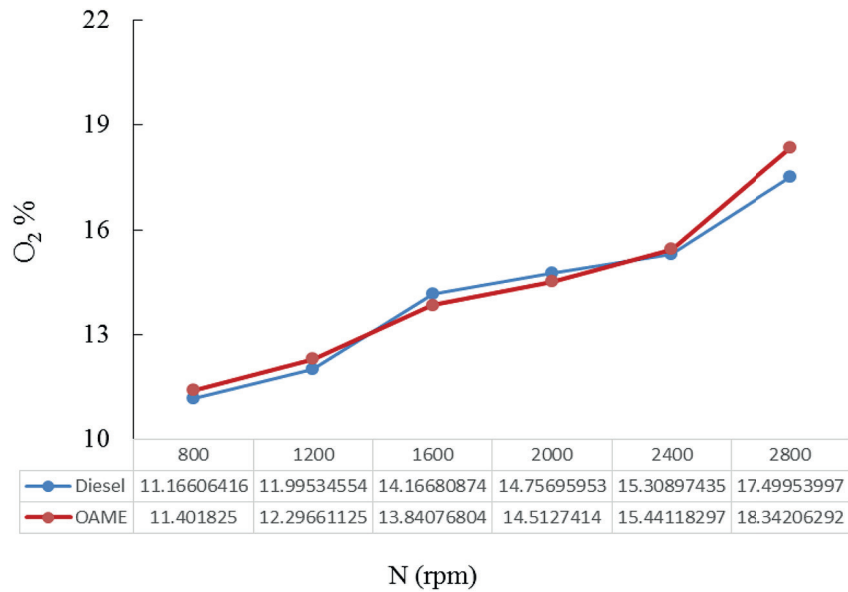

Figure 5. Cycle average of the O₂ emission

Emission of NO

Figure 6 displays the Nitrogen Oxides (NO) emissions of OAME and fossil diesel fuels at the selected engine speeds, expressed in ppm. These findings show that for both fuels under consideration, nitrogen oxide emissions rise as engine speed rises. The engine speed of 1600 rpm results in the greatest NO emissions, which are measured at 1899.39 ppm. The fossil diesel fuel permits a high NO emission at the same speed, equal to 1088.86 ppm. At an engine speed of 800 rpm, the OAME fuel showed the lowest NO emissions, which were 44.28 ppm. The fossil diesel fuel exhibits minimal NO emissions with a maximum of 28.13 ppm at the same engine rpm. Therefore, the greatest temperature of combustion, oxygen concentrations, and residence time all have a

significant role in the creation of the NO (Gonca, 2014; Emaish et al., 2021). In comparison to fossil diesel fuel, the oxygen concentration is higher due to the degradation of biodiesel. This results in a longer combustion time and a considerably higher combustion temperature. The latent heat of vaporization of biofuel is higher than that of diesel fuel, whereas the heating value of biofuel is lower than that of fossil diesel fuel. These physico-chemical characteristics of OAME biofuel help to minimize the in-cylinder temperature’s peak value, resulting in a leaner combustion process.

Emission of NO_x

Figure 7 shows the variation in NO_x emissions, expressed in ppm, for OAME and

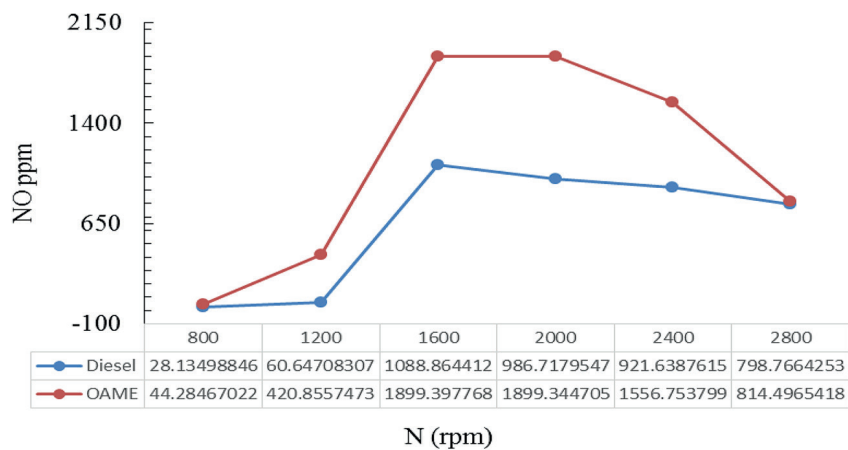

Figure 6. Cycle average of the NO emission

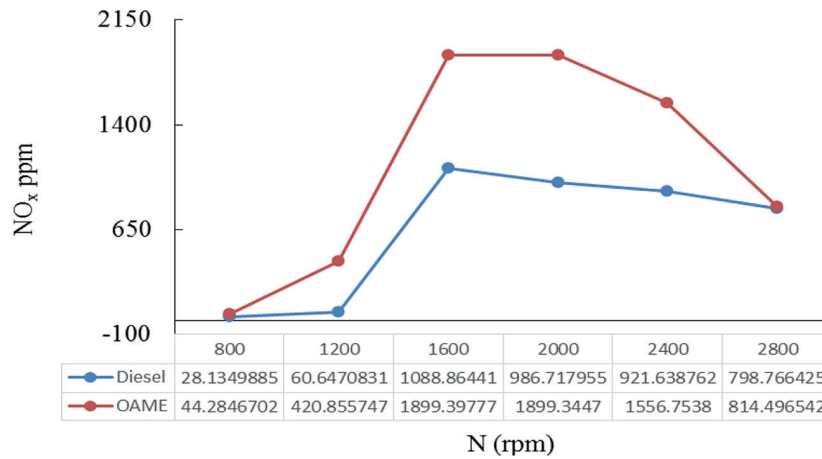

Figure 7. Cycle average of the NO_x emission

conventional diesel fuels at various engine speeds between 800 and 2800 rpm. Because the NO_x emission rises with an increase in combustion and exhaust temperature, these results show that the NO_x is exactly proportional to the engine's power output. The data also indicate that OAME fuel produces significant NO_x emissions, which are around 1899.39 ppm at an engine speed of 1600 rpm compared to 1088.86 ppm for regular diesel fuel. At an engine speed of 800 rpm, low NO_x emission values of 44.28 ppm and 28.13 ppm, respectively, have been recorded for OAME and fossil diesel fuels. The high in-cylinder pressure and temperature at increasing loads may be the cause of the NO_x emission increase as engine speed rises. In fact, the high oxygen concentration of the OAME fuel directly contributes to the high rate of NO_x generation. Due to the oxygen-rich nature of OAME fuel, a high combustion temperature results, which is what leads to a high NO_x generation.

CONCLUSIONS

The findings indicate that the OAME fuel's BSFC is higher than that of fossil diesel. They exhibit this behavior because their heating value per unit mass is substantially lower than diesel fuel's. Performance metrics have consistently indicated that conventional diesel is superior to OAME fuel globally. Therefore, the economic viability and availability of the bio-source are the main factors that determine whether a specific type of oil should be used to make a specific type of biodiesel fuel. Burning OAME fuels results in greater O₂ production than burning diesel fuels, according

to exhaust emissions tests. the emissions of CO and CO₂ when utilizing OAME gasoline. When compared to diesel, the OAME fuel emits less CO and CO₂ into the atmosphere. Nitric oxide (NO) and nitrogen dioxide are components of the nitrogen oxides (NO_x) in the depleting emanations (NO₂). When the load increases, it is excessively high with OAME fuel in comparison to diesel fuel. NO typically emits gas in a manner similar to NO_x. As a result, utilizing this fuel in place of fossil diesel fuel is not controversial because it is regarded as being environmentally good.

REFERENCE

1. Devarajan, Y., Mahalingam, A., Munuswamy, D.B., Arunkumar, T. 2018. Combustion, performance, and emission study of a research diesel engine fueled with palm oil biodiesel and its additive. *Energy & Fuels*, 32(8), 8447–8452.
2. Emaish, H., Abualnaja, K.M., Kandil, E.E., Abdelsalam, N.R. 2021. Evaluation of the performance and gas emissions of a tractor diesel engine using blended fuel diesel and biodiesel to determine the best loading stages. *Scientific Reports*, 11(1), 1–12.
3. Gad, M.S., EL-Seesy, A.I., Hashish, H.M.A., He, Z., Alshaer, W.G. 2021. Combustion and emissions aspects of a diesel engine working with sheep fat oil biodiesel-diesel blends. *Case Studies in Thermal Engineering*, 26, 101162.
4. Gonca, G. 2014. Investigation of the effects of steam injection on performance and NO emissions of a diesel engine running with ethanol–diesel blend. *Energy Conversion and Management*, 77, 450–457.
5. Gupta, H.N. 2012. *Fundamentals of internal combustion engines*. PHI Learning Pvt. Ltd.

6. Hasan, A.B.U.S., Kumar, A., Tripathi, R.K., Ranjan, S. 2021. Performance And Emission Analysis Of Microalgae Biofuel-Diesel Blends In Internal Combustion Engine.
7. Jagadevkumar, A.P., Pravin, V.K. 2020. Evaluation of performance and emission characteristics of heterotrophic *Chlorella protothecoides* microalgae biodiesel and its blends with diesel in a direct injection diesel engine. *Journal of Physics: Conference Series*, 1473(1), 12043.
8. Liu, Z., Yang, X., Yang, X., Zhai, H., Duan, Z. 2022. Performance Evaluation on the In-Cylinder Heat Transfer of a Reciprocating Compressor using CO₂ as a Working Fluid. *Journal of Thermal Science*, 31(5), 1518–1530. <https://doi.org/10.1007/s11630-022-1456-5>
9. Mahalingam, A., Munuswamy, D.B., Devarajan, Y., Radhakrishnan, S. 2018. Emission and performance analysis on the effect of exhaust gas recirculation in alcohol-biodiesel aspirated research diesel engine. *Environmental Science and Pollution Research*, 25(13), 12641–12647.
10. Mata, T.M., Mendes, A.M., Caetano, N.S., Martins, A.A. 2014. Properties and sustainability of biodiesel from animal fats and fish oil. *Chemical Engineering Transactions*, 38, 175–180.
11. Murillo, S., Miguez, J.L., Porteiro, J., Granada, E., Moran, J.C. 2007. Performance and exhaust emissions in the use of biodiesel in outboard diesel engines. *Fuel*, 86(12–13), 1765–1771.
12. Nguyen, T.N., Khoa, N.X., Tuan, L.A. 2021. The Correlation of Biodiesel Blends with the Common Rail Diesel Engine's Performance and Emission Characteristics. *Energies*, 14(11), 2986.
13. Nguyen, T., Pham, M., Le Anh, T. 2020. Spray, combustion, performance and emission characteristics of a common rail diesel engine fueled by fish-oil biodiesel blends. *Fuel*, 269, 117108.
14. Rajan, K., Senthil Kumar, K.R., Rajaram Narayanan, M., Mohanavel, V. 2021. Impact of nozzle opening pressure on the performance and emission behaviours of the CI engine using yellow oleander biodiesel. *International Journal of Ambient Energy*, 42(13), 1499–1505.
15. Ravikumar, R., Kiran, K., Kumar, M.H., Hebbar, G.S., Shetty, A.S.D. 2021. A Comparative Analysis of Biodiesel Properties Derived from Meat Stall Wastes through Optimized Parameters. *IOP Conference Series: Materials Science and Engineering*, 1065(1), 12005.
16. Roy, M.M., Islam, M.S., Alam, M.N. 2021. Biodiesel from crude tall oil and its NO_x and aldehydes emissions in a diesel engine fueled by biodiesel-diesel blends with water emulsions. *Processes*, 9(1), 126.
17. Shepel, O., Matijošius, J., Rimkus, A., Duda, K., Mikulski, M. 2021. Research of parameters of a compression ignition engine using various fuel mixtures of hydrotreated vegetable oil (Hvo) and fatty acid esters (fae). *Energies*, 14(11), 3077.
18. Srinivasan, G.R., Jambulingam, R. 2018. Comprehensive study on biodiesel produced from waste animal fats-a review. *Journal of Environmental Science and Technology*, 11(3), 157–166.
19. Zhang, Z., Jiaqiang, E., Deng, Y., Pham, M., Zuo, W., Peng, Q., Yin, Z. 2018. Effects of fatty acid methyl esters proportion on combustion and emission characteristics of a biodiesel fueled marine diesel engine. *Energy Conversion and Management*, 159, 244–253.