

MONITORING SYSTEM OF EXTREME LOADINGS OF PROPULSION SYSTEM'S FOUNDATION. DESIGN ASSUMPTIONS

Lesław Kyziół, Lech Murawski

Gdynia Maritime University
Faculty of Marine Engineering
Morska Street 81-87, 81-225 Gdynia, Poland
tel.: +48 58 6901480, fax: +48 58 6901399
email: lkyz@skrzynka.pl, lemur@wm.am.gdynia.pl

Abstract

Project of on-line diagnostic (monitoring) system of marine propulsion system working parameters is the authors' general target. Proper propulsion system's foundation is one of the most important parameters for its reliable operation. Different types of quasi-static loadings and dynamic excitations can be observed during ships exploitation. Presented research has been limited to extreme loadings. Underwater explosions or ship groundings are considered examples of extreme foundation loadings. Analysis of the physical parameters of the extreme forces has been presented in the first part of the paper. Water pressure spatial and non-spatial (time) distribution during underwater explosion has been analysed as an example. Short overview of the dynamic mathematical models of underwater explosions is presented. Time function of vibrations acceleration of ship construction is important design assumption of planned Structural Health Monitoring (SHM) system. Propulsion system's foundation loading measurements should take into account general ship hull deformation (in the aft part of the ship) as well as reactions changes of main engine and shaft line bearings. Ship hull deformation should be monitored as quasi-continuous measurements, along whole propulsion system. Optical Time-Domain Reflectometer method (OTDR) is planned for hull deformation monitoring. Propulsion system bearings' reactions are a source of local foundation pads' strain changes. Fibre Bragg Grating (FBG) sensors are the best for that kind of measurements, in authors opinion. Both techniques (OTDR and FBG) have been shortly described in the paper. Scheme of monitoring system of marine propulsion systems foundation's loadings are proposed in the end of the article.

Keywords: *marine structural health monitoring, propulsion system diagnostic, marine engines' foundations, underwater explosion, ship grounding, Optical Time-Domain Reflectometer, Fibre Bragg Grating*

1. Introduction

Proper foundation of the marine propulsion system has important influence on ship reliability. Modern power transmission systems are relatively stiff in comparison to ship hull. Propulsion system foundations are placed on double bottom or decks in main engine room. Optimal interaction between foundation system and ship hull structure is designed and checked by shipyard. But, for aged ships propulsion system foundations might have incorrect characteristics. Especially, excessive loadings acting on ship hull, like underwater explosions or ship's grounding, might be a source of foundation imperfections or even damages. Project of on-line diagnostic (monitoring) system of marine propulsion system working parameters is the authors' general target. The first step of the project is presented in the paper. Short overview of expected extreme loadings is presented in the first part of the article. Two general types of measurements are planned: global deformations of the ship hull and local strain changes of the foundation pads. Optical Time-Domain Reflectometer method (OTDR) is planned for global hull deformation monitoring. Measured system based on Fibre Bragg Grating (FBG) sensors are the best, in authors' opinion, for propulsion system reaction measurements.

Structural Health Monitoring (SHM) is a multidisciplinary research topic devoted to development and implementation of methods and systems that realize inspection and damage detection by

integration of sensing systems with structures [4]. It also includes a variety of techniques related to diagnostics and prognostics. SHM systems also potentially allow the reduction of maintenance costs directly connected to the effectiveness of the non-destructive techniques which are used for the monitoring of important structures, and can be used to conduct non-destructive inspections for areas which have been traditionally difficult to access. The idea of the marine SHM is to build a system that is able to evaluate a condition of a monitoring structure in different environmental and exploitation conditions. A typical structural health monitoring system is composed of a network of sensors that measure the parameters relevant to the state of the structure and its environment. One of the most important information is strain/stress distribution in the structure.

2. Model of the underwater explosions

Underwater explosions (as well as ship grounding) may have big influence on ship propulsion system [3]. Excessive dynamic forces are transferred via ship foundation system. Basic parameters of the underwater explosion have to be taken into account during monitoring system designing. Impact number is simple way for foundation systems (and subsequently bearings) risk estimating:

$$z = \frac{\sqrt{G}}{R}, \quad (1)$$

where:

G – explosive mass [kg],

R – distance between explosive and ship [m].

Impact number is proportional to strain energy of plastic deformation of ship hull plating at normal direction of the impact wave. The impact pressure wave propagates from the explosion center to the surface of the detonation gas bubble [5]. The pressure pulses are repeated several times until the gas bubble float to the surface of the sea. The number of pulses depends on the depth of the detonation. But usually, only first three pulses have significant influence on ship resistance to explosion.

Maximum pressure estimation can be calculated on the base of the well known equation [2]. The pressure profile at the front of the shock wave can be approximated by an exponential curve. Frequency of dynamic pulsations of gas bubbles might be close to natural frequency of ship hull and/or power transmission system. The resonance phenomenon might be observed and the explosion effect might be multiplied. Real pressure explosion is determined by explosive mass, epicenter distance, wave direction and seabed interaction [9]. Simulation of underwater explosion with three gas bubbles and assumed quotient of subsequent amplitude is presented in Fig. 1. Pressure drop is described different by different authors. The highest differences are observed for medium pressure range and are below 30% (2–15 MPa). For planned monitoring system that differences are not-essential.

3. Fibre Bragg Grating measurement techniques

The systems based on fiber optic technique with Fiber Bragg Grating (FBG) strain sensors are one of the most interesting and promising. In comparison to classical strain measuring method based on electric strain gauges, the new technique based on fiber optic technology and FBG sensors is much more stable and the measuring error is much smaller. The main benefits of fiber optic (in particular FBG sensors) have been found in their long-term stability and reliability as well as in their insensitivity to the external perturbations like electromagnetic fields [8]. One of the main advantages of FBG sensors is the ability to measure multiple physical parameters [1]. This ability combined with serial multiplexing of FBG sensors allows for multiple parameters to be monitored. This feature is advantageous in applications where minimal intrusion into an environment is required. Other important advantage of FBG sensor is multiplexing ability – many sensors (to

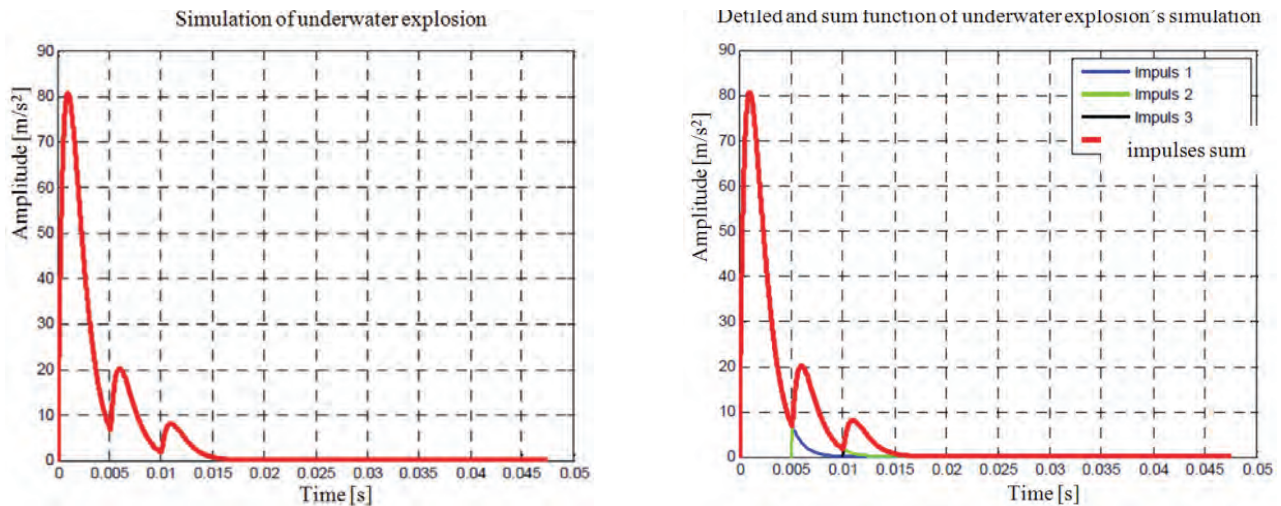

Fig. 1. Simulation of underwater explosion with three gas bubbles and assumed quotient of subsequent amplitude: $A1/A2 = 0.25$ and $A1/A3 = 0.1$ [10]

over hundred) can be multiplexed to provide measurements across the structure [6, 7]. FBG sensors have several promising advantages in comparison to conventional techniques, the main are as follows:

- high sensitivity,
- low sensor's size and mass,
- sensors can be build into the monitored structure (e.g. composite material),
- immunity to electro-magnetic fields,
- applicability to chemical aggressive surroundings,
- multiplexing (hundreds sensors in one channel),
- can support thousands kilometres unrepeated step out distances,
- self-calibrating and free from signal drift (long term stability).

The history of optical fibers reaches back to the 1960's [8]. In 1969 first fibers were manufactured for telecommunication applications by the cooperation of Nippon Sheet Glass Co. and Nippon Electric Co. But these fibers had a damping of 100 dB/km caused mainly by chemical impurity of the glass. Great progress was made in 1976. Improved fibers was available with <1 dB/km. Today the damping is <0.2 dB/km. In 1978 the effect of photo sensitivity for Germanium doped fibers has been found. Exposure to ultraviolet light induces a permanent change of the refractive index. The next step was to use this effect and write Bragg gratings into fibers which then can reflect very small wavelength peaks. The wavelengths of these peaks change with strain and temperature. First commercial FBG sensor was available in 1995 from 3M and Photonetics. Since 2000 about 20 companies offer Fiber Bragg Gratings.

Bragg gratings are written into single-mode fibers. These fibers consist of a very small inner core (diameter 4–9 μm) and an outer part (cladding) of pure glass (SiO_2) of 125 μm diameter. The core has a higher refraction index caused by high Germanium doping. The difference of refraction index between inner core and cladding causes the light to propagate only inside the small core. The glass fiber is coated with acrylate, polyimide or organic modulated ceramic, to protect it especially against water and hydrogen which causes crack growing and can reduce the mechanical stability.

Each single fringe reflects a very small part of all incoming wave. The reflection factor per single fringe is in the range of 0.001% up to 0.1%, depending on how much energy was used to write the Bragg grating and on the percentage of Germanium doping of the fiber core. Each single fringe reflects light with different phase shifts. Therefore, interference is a reason that the most of the light is erased. But the reflections with equal phase shift accumulate to a strong reflection peak. The reflection of whole grating is the sum of all these thousands of very small single reflections. Reflected light travels forth and back in the fiber, therefore reflected light beams of the single grids

are in phase if an integer of light wavelength fits into two times the grid distance. The grid spacing can be calculated as follows:

$$A = \frac{\lambda_0}{2n}, \quad (2)$$

where:

λ_0 – wavelength peak,

n – refraction index of the fiber.

Because typical values of the FBG is: $\lambda_0 = 1550$ nm and $n = 1.46$, the grid spacing should be equal to 530 nm. If the length of the FBG sensor is equal to 5 mm then the number of fringes in the single sensor should be approximately equal to ten thousand.

A FBG sensor (see Fig. 2) has a periodic structure. When light within a fiber passes through a FBG, multiple reflections take place along the entire length of the grating due to the variations in refractive index. Constructive interference between the forward wave and the contra-propagating light wave occurs when the wavelength of the propagating light in the fiber doubles the grating pitch. This leads to narrowband back-reflection of light. A fiber-optic Bragg grating sensor acts as a filter for light running along the single-mode fiber line. Reflected wavelength λ_B is a function of sensor's strain (effected by external stress and/or temperature field). The reflected wavelength is known as the Bragg wavelength λ_B and given by:

$$\lambda_B = 2n_e A, \quad (3)$$

where:

n_e – effective refraction index of the fiber core,

A – the period of the index modulation.

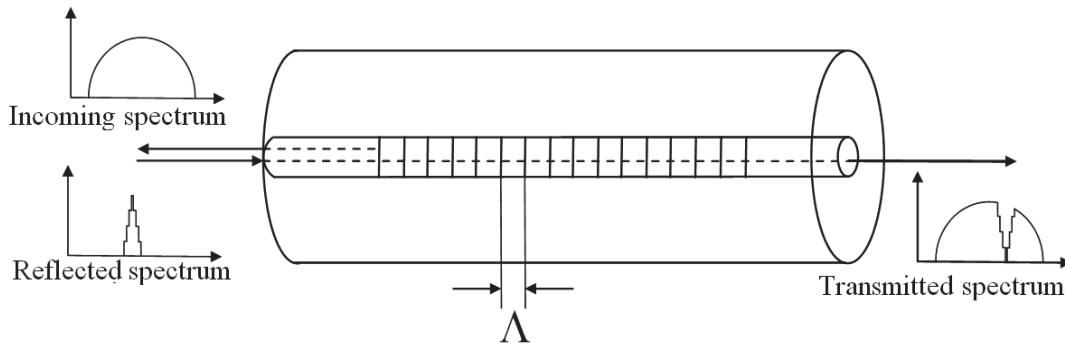

Fig. 2. Scheme of a FBG sensor with reflected and transmitted spectra

Both n_e and A depend on temperature and strain, therefore the Bragg wavelength is sensitive to both strain and temperature. The expansion coefficient of the fiber is negligibly low. The biggest impact results from the temperature dependent change of the refraction index. When a fiber is fixed to a specimen, the FBGs signal changes with the mechanical and temperature caused strain of the specimen. Therefore the thermal coefficient is equal to expansion coefficient of the specimen (not glass). It is lead to equation for strain-measuring FBGs:

$$\varepsilon_m = \frac{1}{k} \cdot \frac{\Delta\lambda_B}{\lambda_B} - \left(\alpha_{sp} + \frac{\alpha_\delta}{k} \right) \cdot \Delta T, \quad (3)$$

where:

k – gage factor,

α_{sp} – expansion coefficient of the specimen,

α_δ – change of the refraction index.

Because temperature has a very strong impact on the FBG sensors, precise strain measurements can only be achieved with proper temperature compensation. When the FBG sensor is fixed to the specimen on a surface without mechanical strain, it works as temperature compensation sensor. Measurements at very high temperatures (hundreds °C) must take into account that the base wavelengths of the sensor change considerably with temperature.

If FBG sensor is strained the wavelength of the reflection peaks is shifted. It is necessary to measure these shifts very precisely. Resolution and short-term stability of ± 1 pm is required. For laboratory investigations, interferometers are often used. In the commercial equipment usually other principles are applied. An example of modern FBG sensor produced by Micron Optics is presented in Fig. 3. Nowadays the top-class instruments are using tunable lasers (see Fig. 3). The interrogator use broad-band light source and therefore only a very small part of the light energy is related to the small bandwidth of a BFG. Therefore the reflected peak energy is very low. A tunable laser concentrates all its energy in an extremely small bandwidth and by sweeping over the whole bandwidth range it scans the spectrum with high power and can provide an excellent signal-to-noise ratio.

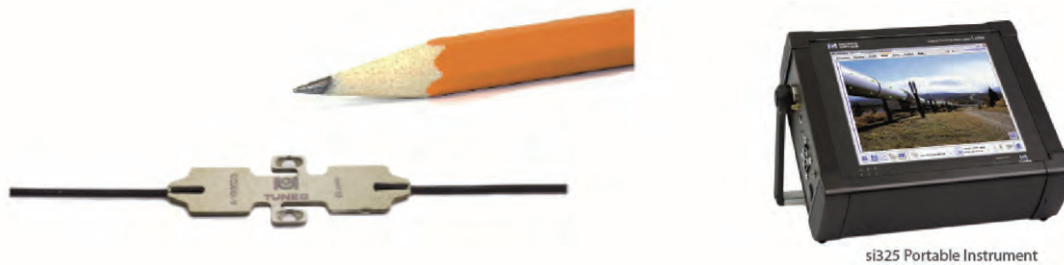

Fig. 3. Micron Optic FBG sensor and Micron Optic portable interrogator

3. Optical Time Domain Reflectometer measurement techniques

An optical time-domain reflectometer (OTDR) is an optoelectronic measurement techniques used to characterize an optical fiber. An OTDR injects a series of optical pulses into the fiber under test. Light is reflected back from points along the fiber. The strength of the return pulses is measured and integrated as a function of time, and is plotted as a function of fiber length. Optical Backscatter Reflectometer (OBR) instruments are used for strain and temperature measuring along pure fiber optic. OBR measuring device can measured with high spatial-resolution, distributed strain and temperature in standard telecom-grade fibers. The OBR uses swept wavelength interferometry to measure the Rayleigh backscatter as a function of length in optical fiber. The system allows practical measuring of distributed temperature and strain in standard fiber with millimeter-scale spatial resolution over tens to hundreds of meters of fiber with strain and temperature resolution as fine as $1 \mu\epsilon$ and 0.1°K .

Measurement techniques are based on Rayleigh backscatter in optical fiber which is caused by random fluctuations in the index profile along the length of the fiber. The scatter amplitude as a function of distance is a random but static property of that fiber can be modeled as a continuous, with a random period. The spectral frequency associated with the Rayleigh backscatter is written in the same form as the reflection frequency of a Bragg grating. Shifts in the fiber index of refraction or in the average perturbation period caused by an external stimulus (like strain or temperature) in turn cause shifts in the local spectral frequency of the Rayleigh backscatter. Accumulated changes along the optical path also manifest as a time shift of the Rayleigh backscatter return loss amplitude pattern. Performing a cross correlation on the backscatter amplitude time domain or frequency domain data accurately measures these spectral and temporal shifts, which are easily scaled to form distributed temperature or strain measurements. An example of the measured signal got from optical backscatter reflectometer offered by Luna firm is shown in Fig. 4. The most important key features and highlights are as follows:

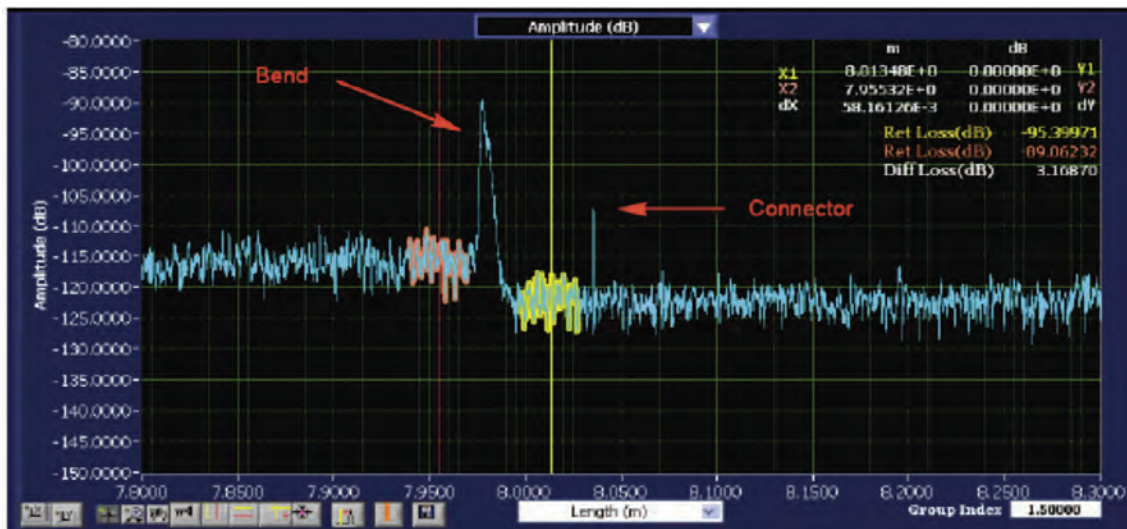

Fig. 4. Example signal from Luna optical backscatter reflectometer

OBR measuring techniques can be used to measure the distributed spectral shift and temporal shift in the Rayleigh backscatter along an optical fiber. This capability enables distributed temperature and/or strain sensing along any standard single-mode fiber. This technique enables robust temperature and strain measurements with high spatial resolution and good accuracy. This measurement capability also provides a practical alternative to fiber Bragg gratings sensors and extrinsic Fabry-Perot interferometric sensor in situations where a large number of closely spaced measurements are desired.

4. General assumption for the monitoring system

Diagnostic system of proper foundation of the marine propulsion system is a target of the author research. Optimal interaction between foundation system and ship hull structure will be checked by the system. General assumption of the project of on-line diagnostic (monitoring) system of marine propulsion system working parameters are analysed in the paper. Two general types of measurements are planned. Global deformations of the ship hull (and external excitations of the foundation system) will be measured by OTDR techniques. Local strain changes (propulsion system reaction) of the foundation pads will be measured by system based on Fibre Bragg Grating (FBG) sensors and interrogators. The scheme of the sensors location is presented in Fig. 5. Continuous recording will be performed by planned monitoring system. Online data analysis allows distinguishing between typical signal (for normal ship operations) and unusual signals coming from extreme loadings. Only those unusual signals will be recorded and deeply analysed.

The „sensor” for OTDR measurement techniques is a typical commercial, telecommunications fibre. On the base of that system, measurements of global deformations of ship hull (in the propulsion system area) is planned. The OTDR based system is dedicated for analysis of quasi-static deformation of propulsion system’s foundation. The sampling frequency of that system will be equal to 3 Hz. The length of the „sensor” will be between 20–30 m. Highest spatial resolution between two measured points is equal to 10 μm , but for our system 10 mm is enough. Expected strain accuracy is about 10^{-5} . Extreme loadings like ship grounding and freak waves (but not underwater explosions) can be measured by the system. Detailed data of continuous distribution of excitation forces acting on propulsion system will be recorded by OTDR based system.

The FBG sensors will be mounted on the foundation pads of the power transmission system. An example of spherical pad with FBG sensor location of intermediate bearing is presented in Fig. 6. Monitoring system based on the FBG sensors will be measured local reactions of the propulsion system’s foundation. The sampling frequency of that system will be equal to 20 kHz. Therefore, that part of monitoring system is dedicated for dynamic analysis of extreme loadings coming from

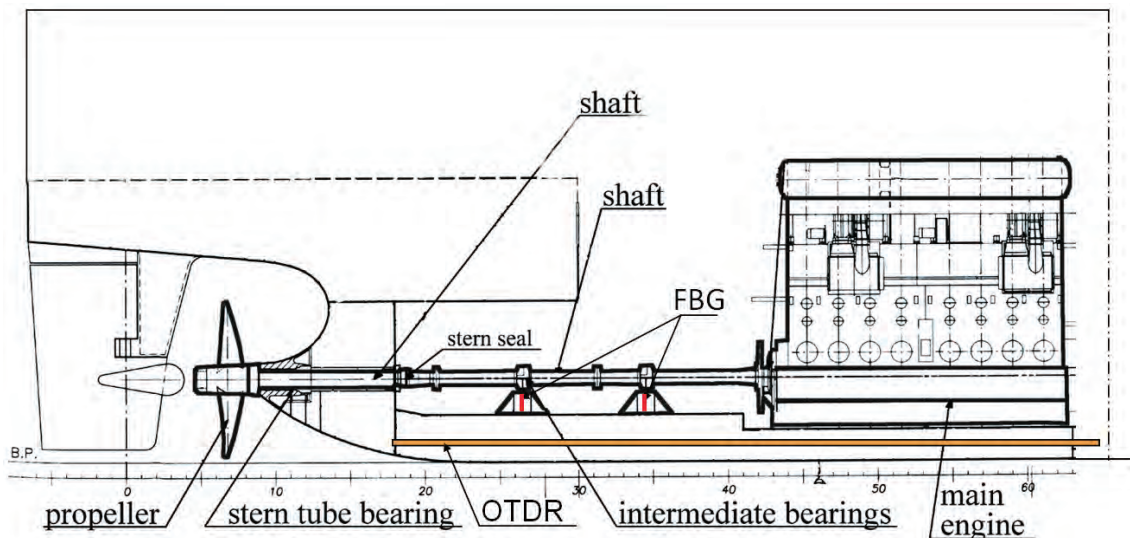

Fig. 5. Scheme of the sensors (OTDR and FBG) location on the ship



Fig. 6. Scheme of the intermediate bearing spherical pad with FBG sensor location

underwater explosions. Of course quasi-static reactions will be also recorded. The typical length of the sensor is between 2–20 mm. For our local strain measurements 10 mm is the optimum length of the sensor. Three FBG sensors for each foundation pad are planned. The sensitivity and accuracy of FBG sensor with typical interrogator is even highest in comparison to OTDR system; therefore it is sufficient for our research. Detailed data of local value of excitation forces acting on propulsion system will be recorded by FBG based system.

References

- [1] Chan, T. H. T., Yu, L., Tam, H. Y., Ni, Y. Q., Liu, S. Y., Chung, W. H., Cheng, L. K., *Fiber Bragg Grating Sensors for Structural Health Monitoring of Tsing Ma Bridge, Background and Experimental Observation*, Engineering Structures, Vol. 28, pp. 648-659, 2006.
- [2] Cole, R. H., *Underwater Explosions*, Princeton, New Jersey 1948.
- [3] Dobrociński, S., Powierża, Z., *The Consequences of Underwater Explosion on the General Cargo Vessel MS „ Józef Wybicki”*, Journal of KONES Powertrain and Transport, Vol. 14, No. 1, 2007.
- [4] Glisic, B., Inaudi, D., *Fiber Optic Methods for Structural Health Monitoring*, John Wiley & Sons, Hoboken, West Suessex, 2007.

- [5] Krzewiński, R., *Dynamika wybuchu, Część 2, Działanie wybuchu w ośrodkach inercyjnych*, WAT, Warszawa 1983.
- [6] Murawski, L., Ostachowicz, W., Opoka, S., Mieloszyk, M, Majewska, K., *Practical Application of Monitoring System Based on Optical Sensors for Marine Constructions*, Key Engineering Materials, Vol. 518, pp. 261-270, 2012.
- [7] Opoka, S., Murawski, L., Wandowski, T., Malinowski, P., Ostachowicz, W., *Damage Detection Experiment on Offshore Platform Leg Model with Usage of Fibre Optic Technique Based on FBG Sensors*, Proceedings of the 8th International Conference on Condition Monitoring and Machinery Failure Prevention Technologies, Cardiff, United Kingdom 2011.
- [8] Udd, E., *Fiber Optic Sensors: An Introduction for Engineers and Scientists*, John Wiley & Sons, New Jersey 2006.
- [9] Wojciechowska B., *Underwater Shock Wave – Empirical Relation*, Journal of KONES Powertrain and Transport, Vol. 14, No.1, pp. 311-320, 2007.
- [10] Grządziela, A., *Model dynamiczny oddziaływania wybuchu podwodnego*, Zeszyty Naukowe AMW, Gdynia, Nr 2 (173), s. 7-17, 2008.