

Michal Hoznedl^{a*}, Lukáš Bednář^a, Ladislav Tajč^b

Changes in aerodynamic parameters for 5-stage steam turbine during warming and gradual start-up to nominal operating parameters

^a Doosan Škoda Power, s.r.o., Tylova 1/57, 301-28, Plzeň, Czech Republic

^b University of West Bohemia, Univerzitni 8, 306-14, Plzeň, Czech Republic

Abstract

The results of experiments on the 5-stage steam turbine are presented. The parameters of individual stages as well as the whole turbine are observed during the gradual start-up to nominal operating parameters. The pressures and temperatures are shown at stages in idling, heating up the experimental turbine and during the transition to operating speed. A greater attention is devoted to three selected operational conditions with different processed enthalpy drops. Problems with efficiency and enthalpy drops measurement during warming are described. The attempts to measure flow parameters quickly and without time for heating of turbine casings and other parts are often in the experimental research caused by price of the survey. This contribution's task is to inform about these situations and to avoid confused and untrue results obtained by somewhat hasty measurements due to reduction and optimisation of costs.

Keywords: Steam turbine; Experimental measurement; Warming; Start-up; Efficiency

Nomenclature

| | | |
|-----|---|---|
| c | – | velocity calculated from enthalpy drop over a stage |
| G | – | mass flow rate |
| h | – | used enthalpy drop |
| n | – | speed of revolutions |
| p | – | pressure |

*Corresponding Author. Email address: michal.hoznedl@doosan.com

| | | |
|-----|---|-----------------------|
| s | – | entropy |
| T | – | time |
| t | – | temperature |
| u | – | circumferential speed |
| V | – | volumetric flow |

Greek symbols

| | | |
|---------------|---|-----------------------------|
| η | – | efficiency |
| ε | – | pressure ratio over a stage |

Subscripts

| | | |
|------------|---|---|
| b | – | chord of stator blade |
| tot | – | total |
| is_tot | – | isentropic enthalpy drop over the whole flow path |
| tt | – | from temperatures |
| m | – | mean value |
| m_opt | – | mean value for optimal isentropic drop over the whole flow path |
| avg_opt | – | average value of velocity ratio for 3000 rpm |

1 Introduction

When, designing the high pressure (HP) part of 1000 MW turbine powered by saturated steam as a two stream one, for experimental verification of the main aerodynamic parameters also a 1:1 scale one-stream variant was built. The superheated steam at the inlet to the experimental turbine was set. In the experimental turbine with the maximum output 10 MW it was possible to trace the course of the expansion in individual stages and to define their efficiency as well as the efficiency of the whole turbine. The experimental turbine allowed for changes to input parameters of the steam (pressure and temperature). The output pressure could not and be regulated, is depend on the cooling water temperature and the vacuum reached. Unlike the real operation in the power plant, where the steam expansion occurs at all stages in wet steam, in the model turbine the expansion proceeded in superheated steam. The expansion itself was shifted to the lower pressure level. It was desirable to keep the same volume flows through the turbine as in the plant. The aim of this investigation to map the course of the expansion at individual stages; from idling, while heating the turbine, to the required operating parameters, see [1].

Measured aerodynamic data obtained from insufficiently warmed steam turbine could lead to the confusing and untrue conclusions. The goal of this paper is also to point out these practical problems.

Up to now, there were no publications dealing with the steam turbine aerodynamic parameters behaviour during warming and starting-up. Some publications

deal with warming-up of the metal parts of the turbine, relative shifts of stator and rotor parts and their deformations [2-3]. Other, papers deals with similar problems, which means decreasing of starting-up time for steam turbines operating in solar field [4] or the turbines put into combined cycle [5]. Overall view on steam turbine measurement provides [6].

2 Experimental turbine

The experimental turbine with a 5-stage rotor is shown in Fig. 1. The temperature between the stages is measured by resistance thermometers. Before and behind each stage a pressure tap is installed. Before the 1st stage the total and static pressure is measured with the help of a rake probe. Behind the 5th stage the pressure is measured on both limiting walls, which means on the hub and tip. All pressure taps and thermometers are doubled. They are located on the left and right side of the turbine. There are no sensors between nozzles and blades because of bad accessibility. Maximum inlet temperature is 250 °C and inlet pressure 1.3 MPa. Absolute value of uncertainty of temperature and pressure measurement is ± 0.9 °C and ± 75 Pa, respectively. Bearings and control system are designed to reach 8000 rpm. The required speeds and the torque moment are controlled and measured by a water brake. Measured speed has uncertainty at level ± 1 rpm and torque measurements' relative uncertainty is lower than $\pm 0.15\%$. The outer casing includes a number of flanges enabling access to all inner parts of the turbine. These also facilitate the installation of the sensors needed for measuring the required aerodynamic parameters of the steam at the individual stages. The mass flows of the steam can be specified by the amount of the condensate collected in measuring tank. Maximal steam mass flow is 70 t/h. Steam mass flow measurements' relative uncertainty reached by water tank is $\pm 0.2\%$. The input temperature of the steam is regulated by water injection. The turbine is fed by steam as well as cooling water from a neighbouring power plant. Inlet parameters (temperature and pressure) are kept constant by a turbine control system, outlet pressure is dependent on cooling water temperature.

The basic data about the blade rows is presented in Tab. 1.

3 Aerodynamic parameters at stages for variable turbine loads

The transition from the turbine start-up to the nominal parameters has its characteristic phases. In the initial phase the main process is heating of the turbine.

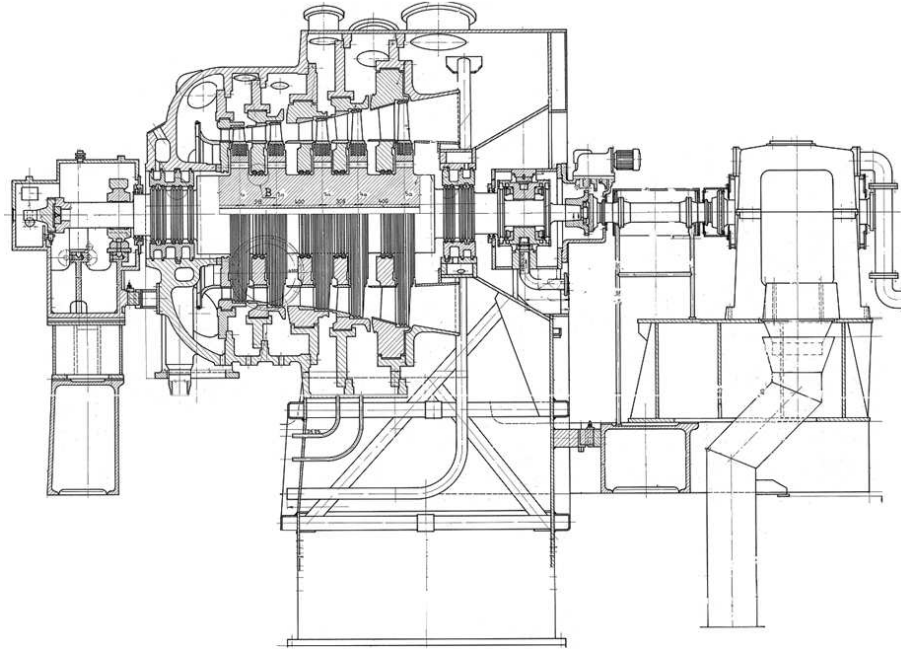

Figure 1: Experimental high pressure turbine assembly schems.

Table 1: Description of basic stage parameters.

| Stage | HP 1 | | HP 2 | | HP 3 | | HP 4 | | HP 5 | |
|---------------------------|--------|-------|--------|-------|--------|-------|--------|--------|--------|--------|
| Blade row | stator | rotor | stator | rotor | stator | rotor | stator | rotor | stator | rotor |
| Chord b_{mid} , mm | 112.5 | 115.4 | 186.8 | 115.4 | 185.8 | 115.4 | 186.6 | 118.92 | 193.8 | 123.92 |
| Blade length l , mm | 99 | 113 | 134.7 | 152 | 169 | 187 | 231 | 253 | 309 | 329.1 |
| Root dia D_{root} , mm | 1258 | 1250 | 1258 | 1250 | 1258 | 1250 | 1258 | 1250 | 1258 | 1250 |
| Ratio of l/b_{mid} , - | 0.88 | 0.98 | 0.72 | 1.32 | 0.91 | 1.62 | 1.24 | 2.13 | 1.59 | 2.66 |
| Blade number z , - | 54 | 54 | 36 | 54 | 36 | 54 | 32 | 54 | 38 | 54 |
| Stage reaction ρ , - | 0.14 | | 0.30 | | 0.33 | | 0.38 | | 0.45 | |

The rotor speed is kept at a minimal level. The transition to operational speed follows, without loading the turbine. The generated output serves only to cover losses in bearings and ventilation losses on the bladed discs. In the final phase of the start-up process the output increases. Gradually a bigger enthalpy drop is processed. At design parameters the turbine should work with maximal efficiency

at all stages. This process should be also modeled on the experimental turbine. The gradual loading of the turbine is then controlled by the water brake.

For idling the steam is expected to flow only partly through the stages. Mainly in the end part of the blade system the stream disruption is likely to happen, which is related with the occurrence of local vortices. Under the influence of turbine heating and steam throttling, the steam temperature is expected to increase disproportionately at the last stage. It could be partially caused by the occurrence of areas with local vortices, which generate additional frictional heat hard to be removed.

First stages can drive back stages in the outlet part of the turbine, where the influence of ventilation losses is mainly expected. The system of temperature and pressure measuring at individual stages enables to verify the whole system of steam expansion in all phases, i.e., from the heating to speed start-up and further increase of the turbine output. The experiment has provided the possibility to check whether the overheating of the outlet part during turbine start-up was realistic.

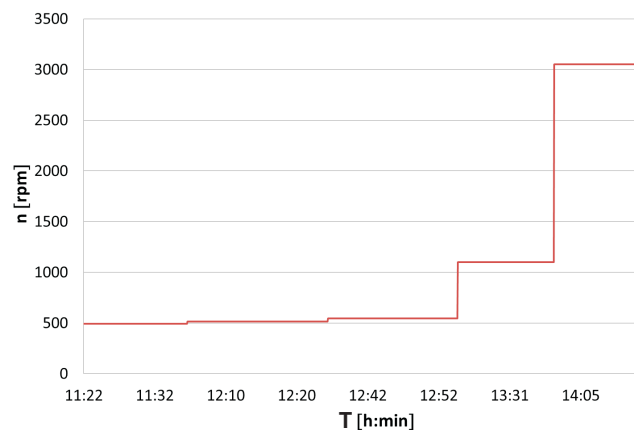

Figure 2: Speed changes in start-up: n – revolutions per mint, T – time.

In Fig. 2 the changes of speed in time are shown. During the turbine heating the speed was kept at 500 rpm. The transition to full speed was fast. It is controlled by the regulation system of the turbine. A smaller time delay at the speed about 1000 rpm is desirable to cross over critical speed. The increase of isentropic enthalpy drop over the whole turbine, h_{is_tot} , is shown in Fig. 3. Heating the turbine is time consuming. It is a process that in experimental turbine takes up to 4 h. The transition from actually zero to 100% load can be then quick. Considering the implemented measurements a gradual transition

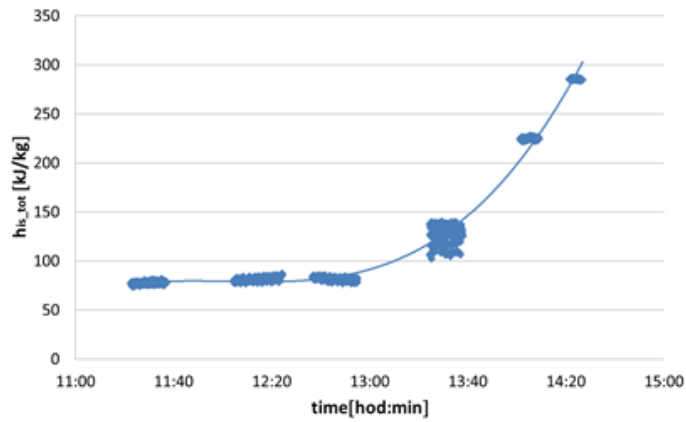

Figure 3: Increase in enthalpy drop in start-up.

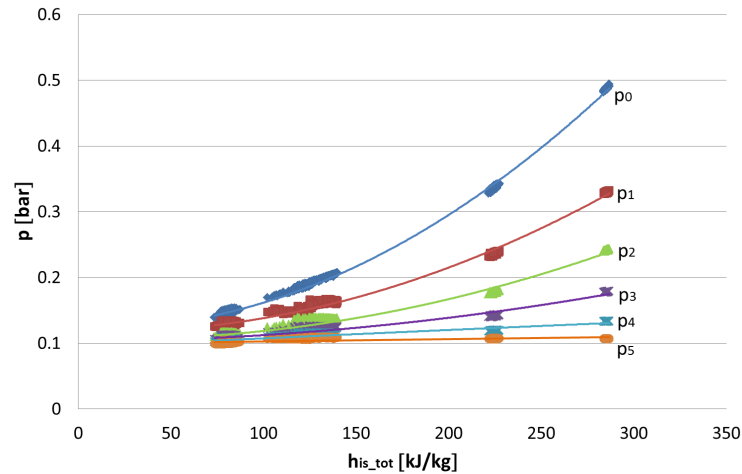

Figure 4: Pressures at five stages during start-up to full load.

to nominal parameters was chosen. The courses of pressures and temperatures in the gradual loading of the turbine are given in Figs. 4 and 5. Parameters indexed as 0 mean inlet to the turbine, index 1 is behind the 1st stage, etc. Input parameters of the steam upstream the turbine are influenced by steam throttling in the regulation valve. By the change in the flow area of the valve the required enthalpy drop and thus the required steam mass flow is controlled.

In the phase of the turbine heating, the steam temperature before the turbine was kept at the temperature about $t_0 \approx 220^\circ\text{C}$. The steam mass flow rate to the turbine, G , reached 7 t/h, see Fig. 7. The steam temperature at the rotor outlet

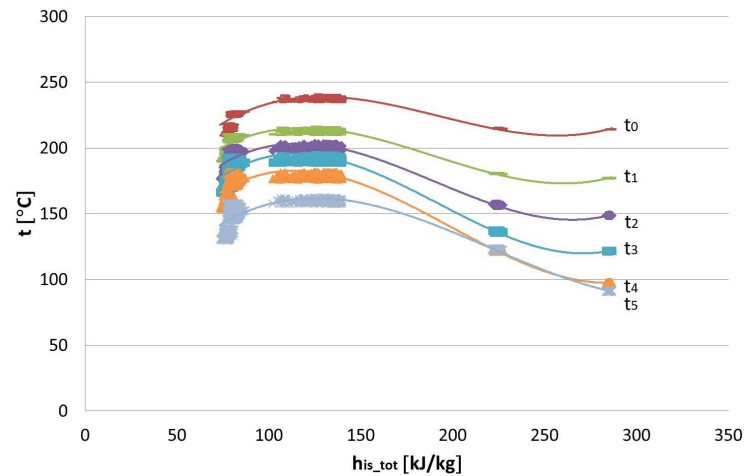

Figure 5: Temperatures at five stages during start-up to full load.

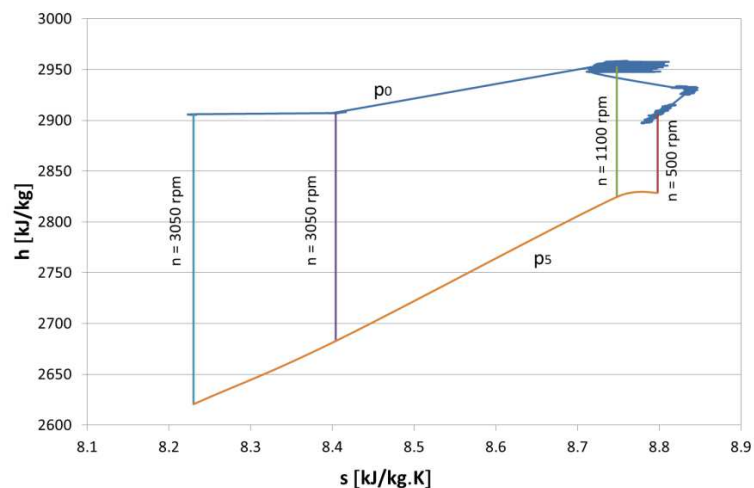

Figure 6: Steam expansion on the turbine for various loading phases.

increases gradually up to $t_5 = 150\text{ }^\circ\text{C}$. The isentropic drop during the heating was stabilized at about 70 kJ/kg .

Individual phases of isenthalpy drop during the start-up to operating speed and load are shown in Fig. 6. The increase of rotor speed is accompanied by the increase of bearings' and ventilation losses. For this reason even the inlet pressure of the turbine is rising. A greater enthalpy drop is processed. During the speed changes enthalpy drop increases from 70 kJ/kg up to 150 kJ/kg . Further increase

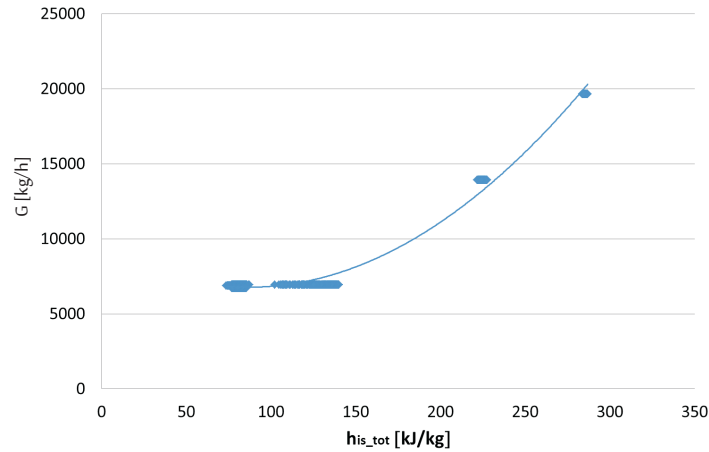

Figure 7: Mass flow in turbine during start-up to full load.

in enthalpy drop is related with a more substantial increase of turbine output. It gradually reaches 280 kJ/kg. The increase in speed from 500 to 3000 rpm is accompanied by a temporary increase of inlet temperature which finally reaches value of 240 °C.

A higher inlet steam temperature, as shown in Fig. 7, did not influence the mass flow through the turbine. It remained at the level of 7 t/h. Increasing the turbine output is related even with the increase of mass flow. The steam temperature behind the last stage in the phase of heating and start-up to full speed grows permanently. Only when loading the turbine and increasing the output, the temperature decreases. Maximal heating of the outlet part of the turbine depends on the time of heating and staying at full speed without loading the turbine. In experimental turbine in transition from idling to full load the outlet temperature t_5 dropped from 160 °C to 80 °C, see Fig. 5.

Using recorded temperatures and pressures during the turbine start-up process to full load, both isentropic and the real enthalpy drop over the whole turbine can be specified, these are processed in Fig. 8. It is evident, that against expectation in the phase of turbine heating and full load start-up the real drop is greater than the isentropic one. It of course means that turbine efficiency, η_{tt} , is higher than one. The turbine efficiency is given in Fig. 9. States when $\eta_{tt} > 1$ are unrealistic. The η_{tt} is efficiency obtained by measurement of enthalpies both at the inlet and outlet from the blading. It is only possible by considerable heat draining and steam cooling during the expansion. Even if the thermometers are placed in the central part of the blade channel, the heat draining from the steam over the blades

causes distortion of processes in the flow part of the turbine. It means that more time is needed to set the realistic temperature ratio at individual stages. With increasing turbine output its efficiency is increasing too, which is demonstrated by decrease of outlet temperature. Thus convergence of blade temperature during the heating and the temperature of steam expansion occurs at stages. The process of detailed measurement of aerodynamic parameters at individual stages is modified so that the optimal operating states are reached after the longest time from start of the heating. The influence of heat distribution through surrounding areas on the measured parameters, must be taken into account. The temperature after the last stage can be mainly influenced by the heat leaving or even entering the machine's parts. It also relates to the impact on thermodynamic efficiency of the turbine.

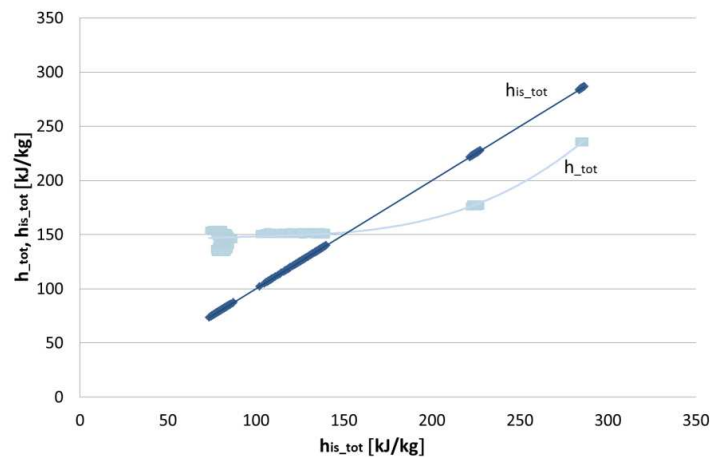

Figure 8: Real and isentropic drop in start-up.

Isentropic and real enthalpy drop in individual stages for turbine start-up to operational parameters are shown in Figs. 10 and 11. During the turbine heating at the speed 500 rpm the 1st and 2nd stages drive the remaining three stages. It corresponds with the pressure drop at stages and the course of isentropic enthalpy drop for individual stages, h_{is} . The increase of speed from 500 to 3000 rpm is accompanied by increased diffusion of the processed enthalpy drops. The changes of real enthalpy drop at the 5th stage are different from the course of the change at other stages. While at most stages enthalpy, h , increases with the increase of isentropic enthalpy drop over the whole flow path, h_{is_tot} , at the 5th stage h decreases. It is the consequence of the temperature changes in the rotor's and stator's parts during the heating and gradual start-up to the full load. The ef-

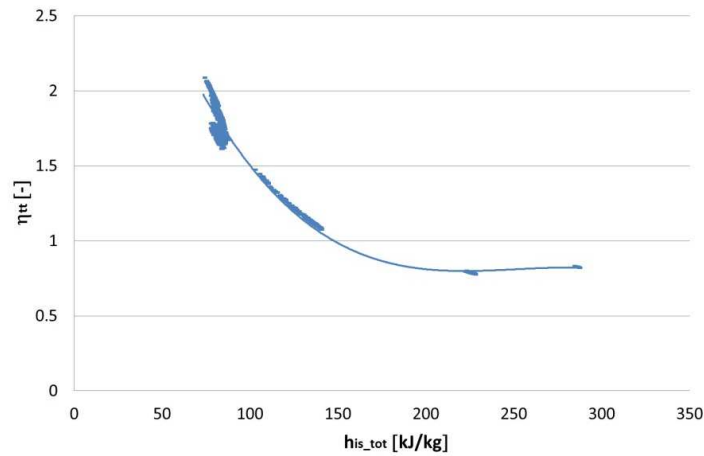

Figure 9: Turbine efficiency in start-up.

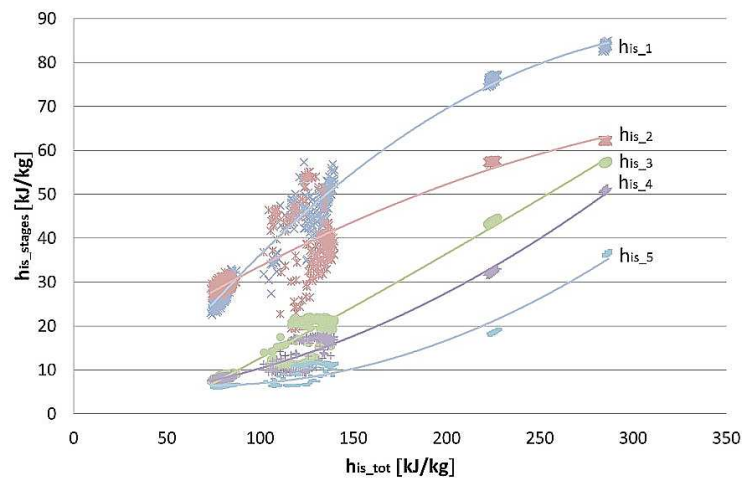

Figure 10: Isentropic drop at stages in start-up.

efficiency of individual stages determined from recorded temperatures during the heating and the start-up to full load is shown in Fig. 12. The efficiency of the 4th stage is higher even at the nominal operation. Probably the reason is the heat transfer between outlet from this stage to the last stage. Temperature was measured locally and the temperature field behind stages is unequal and the measurement error is high. The efficiency levels of particular stages are not highly representative. In the first stage the steam temperature is lowered by the contact with unheated blades, which is demonstrated at most stages by artificial improve-

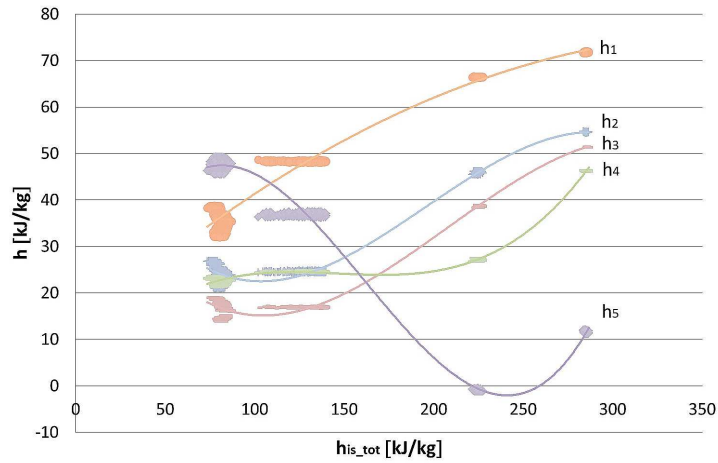

Figure 11: Real drop at stages in start-up.

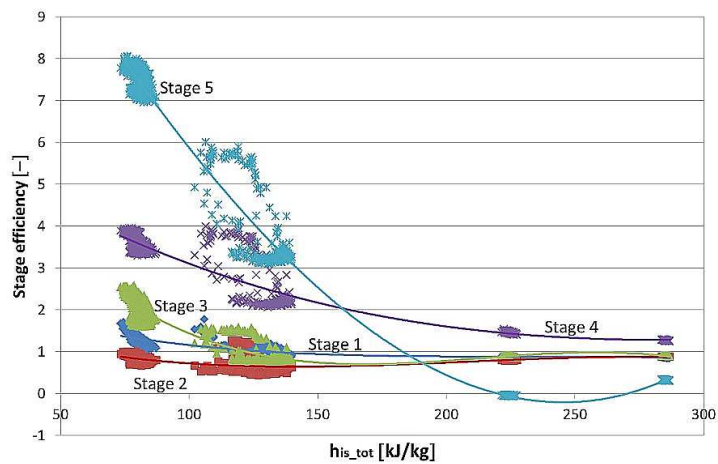

Figure 12: Efficiency of particular stages in start-up.

ment of efficiency. The efficiency cannot be at any stage higher than one. The most significant changes concern the last stage in the row, i.e., the 5th stage. The characteristic course of expansion in various phases of the heating and during the start-up to the full load is depicted in Figs. 13 and 14. With the growing load of the turbine the expansion at individual stages is gradually stabilized. But it can not be ruled out whether even at full load with $h_{is_tot} = 338$ kJ/kg, the operation of the 5th stage is not altered by the influence of heat transition. It is indicated also by the finding from the course of efficiency determined using the torque on

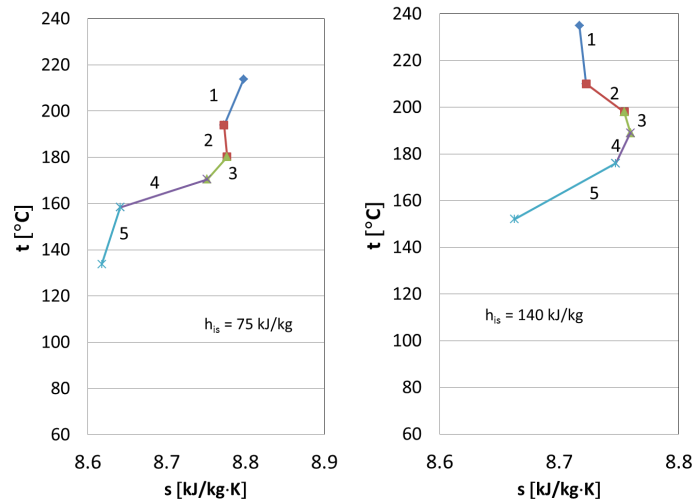

Figure 13: Expansion at stages – ventilation regimes.

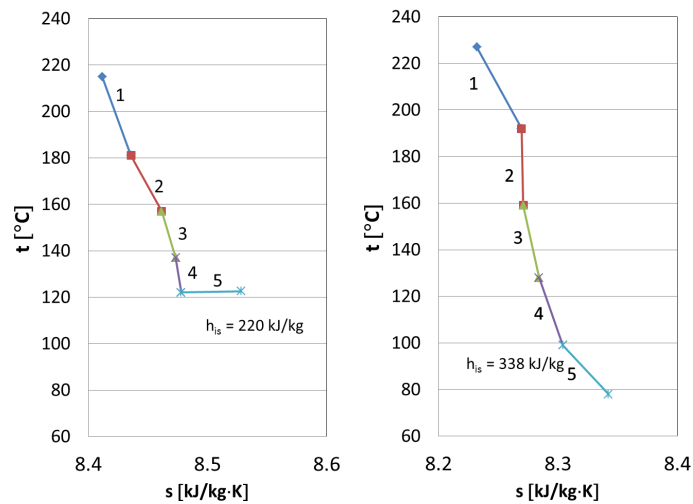

Figure 14: Expansion at stages – working regimes.

the water brake, see Fig. 16. Thermodynamic efficiency, which has been of the turbine measured by the brake is always less than one, $\eta_b < 1$, and for regimes close to nominal states is higher than efficiency specified from temperatures at individual stages. The tested regimes for states close to the optimal operation of the turbine are shown in Fig. 15.

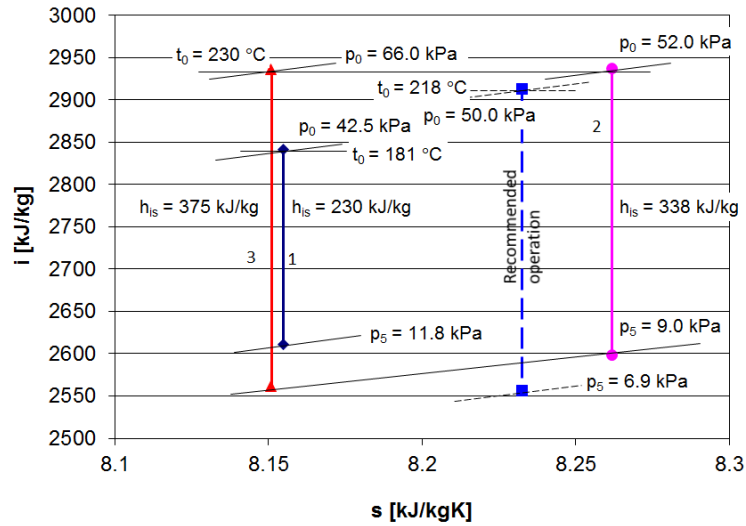

Figure 15: Turbine regimes close to optimal operation with maximum efficiency.

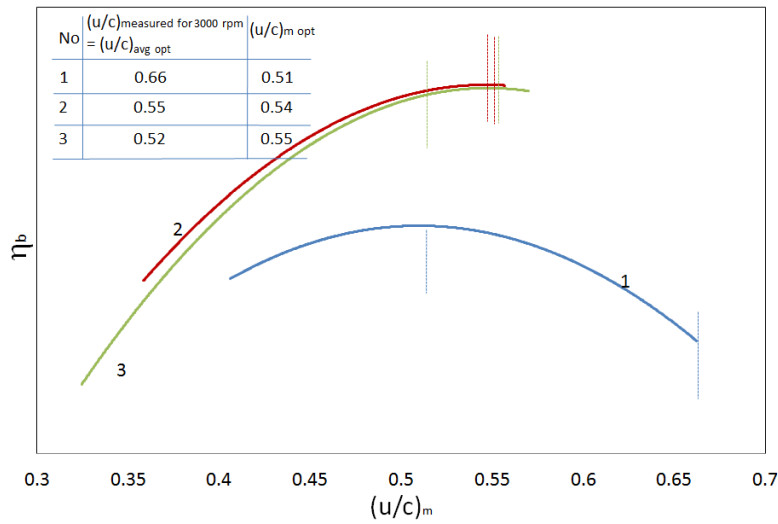

Figure 16: Efficiency of turbines in tested regimes.

The efficiency from the brake for these regimes is shown in Fig. 9. For drop $h_{is_tot} = 0$ must be $\eta_b = 0$. From the mutual comparison of the course of η_b and η_{tt} the influence of the heat transfer from the steam to the turbine casing is obvious as well as its impact on the distortion of the efficiency specified from

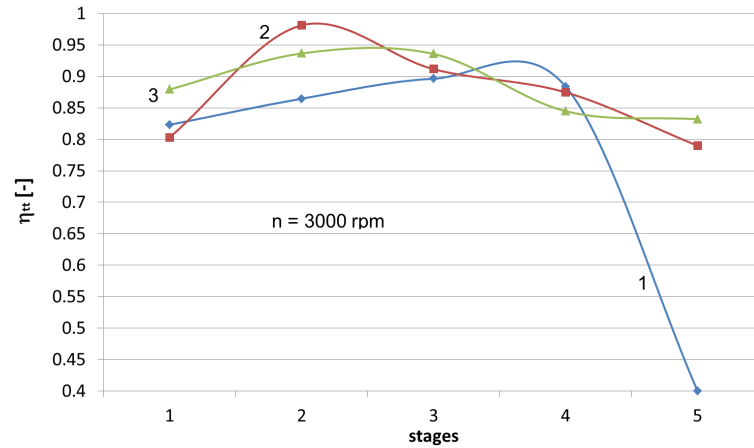

Figure 17: Efficiency of individual stages in tested regimes.

temperatures. A detailed course of efficiencies defined using water brake, for the three observed regimes, is shown in Fig. 16. The efficiency for speed $n = 3000$ rpm is also given there. The $(u/c)_{avg_opt}$ is defined as the average velocity ratio (u/c) over the whole turbine flow path measured for nominal rotational speed 3000 rpm

$$(u/c)_{avg_opt} = \sqrt{\frac{\sum u_{i,3000\text{ rpm}}^2}{2h_{is,3000\text{ rpm}}}},$$

where $u_{i,3000\text{ rpm}}$ is measured rotational speed for i th stage at the blade root for 3000 rpm, $h_{is,3000\text{ rpm}}$ is measured isentropic drop over the whole flow path for 3000 rpm. Instead, the $(u/c)_{m_opt}$ is defined as the average velocity ratio (u/c) over the whole turbine flow path which provides the best efficiency. Difference between $(u/c)_{avg_opt}$ and $(u/c)_{m_opt}$ is smallest for the measurement 2, see Fig. 16. Measurement 2 is closest to nominal conditions. The biggest difference between $(u/c)_{avg_opt}$ and $(u/c)_{m_opt}$ is for the measurement 1. Operational conditions for the measurement 1 at 3000 rpm were far from optimal conditions. Optimal isentropic drop means the value, where the efficiency of the whole flow path is maximal. The efficiency at individual stages is shown in Fig. 17. The stage efficiency is determined using measured temperatures. When lowering the enthalpy drop over the whole turbine, the decrease in efficiency is manifested most significantly at the 5th stage.

There is undoubtedly a connection with the change in operating parameters at stages. The course of changes in steam volumetric flow occurring at stages is shown in Fig. 18. Just at the 5th stage the changes are most dramatic. The differences

between enthalpy drops processed at stages tend to increase. As shown in Fig. 19 for the 1st load variant their scope from the 1st to the 5th stage decreases.

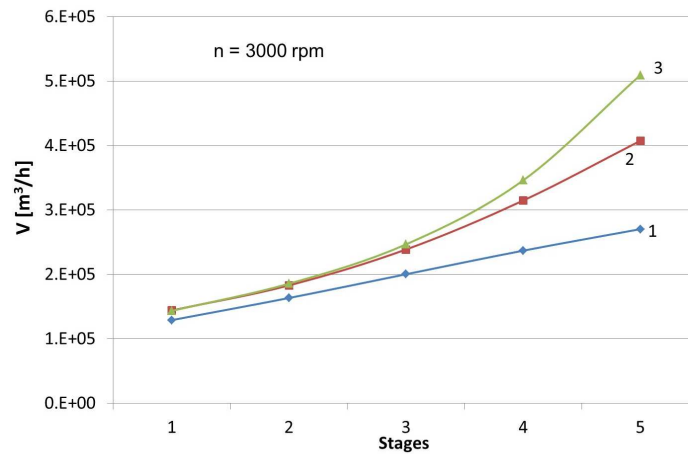

Figure 18: Steam volumetric flow at stages.

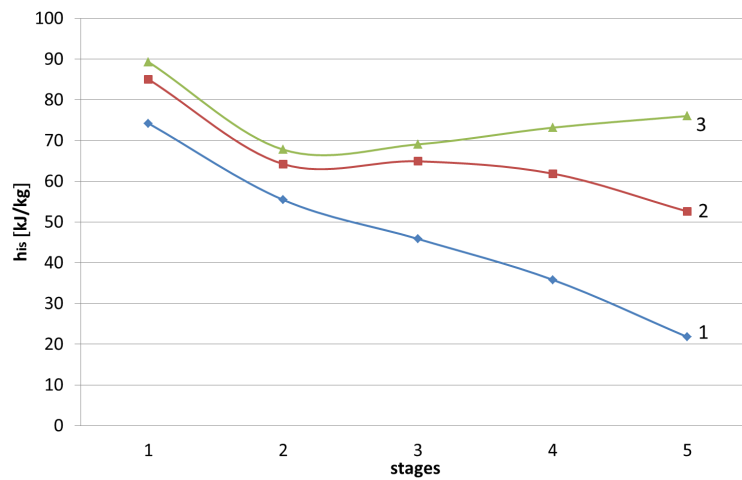

Figure 19: Enthalpy drops at stages.

It is demonstrated in the pressure ratio, ε , at stages. It is already defined as $\varepsilon_{behind\ stage}/\varepsilon_{before\ stage}$. Their courses are shown in Fig. 20. At the 5th stage it can happen that for a lower mass flow the steam goes only through a part of the stage. The stream is separated and a local vortex appears what results in decrease of efficiency. A possible influence of steam heating by heat transfer over the casing

cannot be ruled out either. It is proved by a lower turbine efficiency specified from temperature measured behind the 5th stage. Comparison of thermodynamic efficiency of the turbine specified using the brake and temperatures for the three considered operation variants is in Fig. 21.

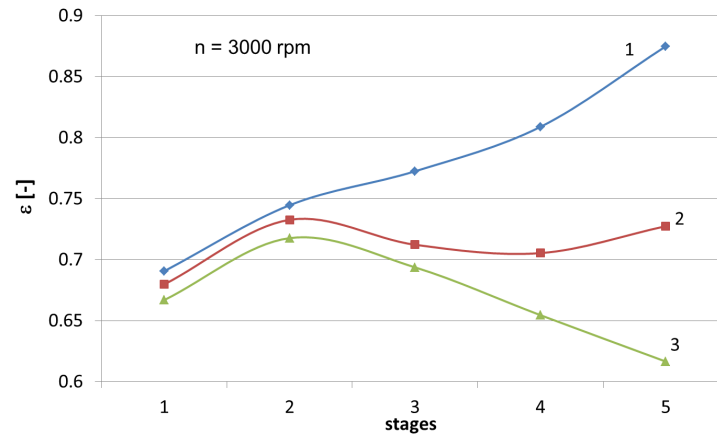

Figure 20: Pressure ratio at stages.

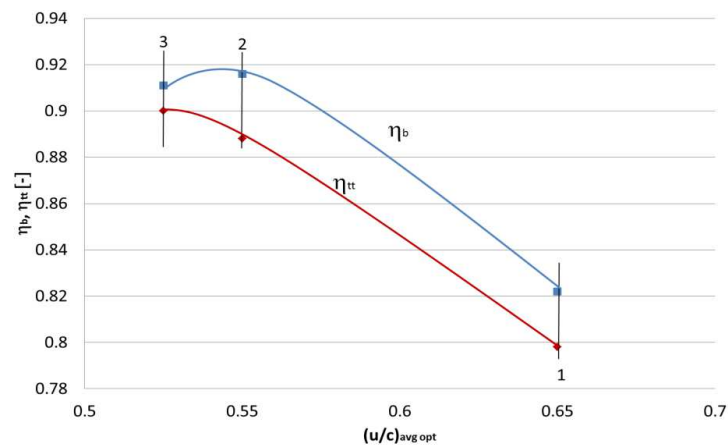

Figure 21: Comparison of efficiencies from temperatures and pressures.

As there is no steam outtake and the thermometer is placed in the central part of the stage, it is possible to explain the causes of existing difference in efficiencies by heat transfer between the turbine casing and the steam flowing through the stage.

4 Conclusions

1. In the phase of turbine heating can occur states when the heat from the steam throttled to lower pressure is taken to the cooler casing. In this way the turbine efficiency assessed from temperatures seems to be better. At stages it may yield even an unacceptable result even $\eta_{tt} > 1$, however the real efficiency specified using water brake is always lower with $\eta_b < 1$.
2. After transition to operational parameters that are close to the optimal turbine load, the heat flow can even converse and heat the steam in the blade area. It is demonstrated by worsening of efficiency specified from temperatures.
3. The last stage is most sensitive to the load changes. For lower load the steam can flow only through a part of the stage. The stream separation and local vortexes can occur.
4. More considerable blade heating cannot be confirmed as a result of bad heat distribution by the influence of ventilation losses in idling. The time of turbine operation without the full load matters here.
5. Temperature measurement is local and does not give any information about temperature flow field in given cross-section. Pressure fields behind stages are much more uniform.
6. Turbine casings work as heat exchangers during start-up. Aerodynamic parameters of steam are influenced by heat transfer even they look stable in time. Especially temperatures and efficiencies of particular stages are strongly influenced by even negligible heat transfers.
7. Experimental research is very important and irreplaceable especially when it is done in steam conditions. On the other hand, the price of the steam and turbine operation is very high and there is still demand to decrease measurement time to minimum. There is a necessity to observe steam and metal temperatures and evaluate their derivation in time. Even when the derivative will be as zero, it is necessary to wait for a longer time for entire turbine uniform warming. This prolongation should be at least in tenths of minutes.
8. Using of the torque and mass flow for efficiency evaluation compare to the temperature and pressure measurement is preferred. Exact determination of the efficiency of particular (two) stages is possible by using of two-rotor configuration of the turbine.

Received in July 2016

References

- [1] Hoznedl M., Bednář L., Miczán M., Tajč L.: *Influence of operating parameters on thermodynamic efficiency of experimental turbine with 1000 MW HP part*. In: Proc. Conf. Symcom 2014, Lodz 2014, 51–52.
- [2] Banaszkiwicz M.: *Steam turbine start-ups*. Transactions IFFM, **126**(2014), 169–198.
- [3] Ehrt A., Schreier T., Brunner P., Abhishek M.: *Steam turbine start-up optimization tool based on ABAQUS and python scripting*. In: Proc. Simulia Customer Conference, London 2009.
- [4] Spelling J., Jöcker M., Martin A.: *Thermal modeling of a solar steam turbine with a focus on start-up time reduction*. J. Eng. Gas Turb. Power – T. ASME **134**(2012), 1, 1013001–013001-8, DOI:10.1115/1.4004148.
- [5] Alobaid F., Postler R., Ströhle, Epple B., Kim H.G.: *Modeling and investigation start-up procedures of a combined cycle power plant*. J. Appl. Energy **85**(2008), 12, 1173–1189, DOI:10.1016/j.apenergy.2008.03.003.
- [6] Albert P.: *Steam Turbine Thermal Evaluation and Assessment*. GE Power Systems, GER-4190.