

COOLING OF REMOVABLE BATTERY PACK IN THE ELECTRIC CAR

Władysław Mitianiec

Cracow University of Technology
Jana Pawla II Av. 37, 31-864 Krakow, Poland
tel.: +48 12 6283692, fax: +48 12 6283690
e-mail: wmitanie@usk.pk.edu.pl

Abstract

The thermal management system is the one most important unit in the electric car which controls temperature of electric devices by obtaining a stability of their operation in different load and ambient conditions. For the other side the removable pack installed in the closed cradle for easier service during exchange of the modules should be cooled by the air. It is also better for safety during exploitation for the vehicle parts and people. The paper presents the proposal of ventilation of battery packs, assumptions of the battery pack cooling system, mathematical model of heat exchange and graphical results obtained from simulation carried out using the CFD program. During modelling it took into account two models: two-dimensional and three-dimensional for evaluation of the air flow and cooling rate of the battery modules. It was assumed four modules in one row of the cradle with total electric capacity above 4 kWh. The paper shows geometry of the whole battery unit with ventilation passages in 3D configuration. The aim of the work was determination of thermal parameters of the battery modules cooled by the air flow in the close chamber. The proposed cooling model of the cradle with air flow caused by fans in the pipe inlet shows that it is not possible to decrease temperature in the same way of each battery modules.

Keywords: transport, electric cars, battery, cooling system

1. Introduction

Modern electrical vehicles require batteries with high electric capacity. Despite of using of new technology the weight of batteries is still too high. For higher driving distance there is needed an additional battery in the form of removable battery packs located in the front or in the rear of vehicle. Additional battery pack containing cell modules in different configurations requires electric interfaces. Because battery modules work at high load particularly with high current at constant voltage their work temperature increases and for long working time cooling of the system is necessary. The battery pack is located in the cradle consisting of a base mounted to the car, electric interfaces, flow ducts for cooling medium, fixation elements of the battery modules and a upper cover. For convenience the air cooling system is generally used because it can discharge the toxic gases from the battery modules. Such cooling system equipped with air fans enables distribution of the air in the space of the battery compartment. The air is in most taken from the passenger cabin because is filtered and does not contain any dust and solid parts. The cradle of the removable battery packs should be convenient for handling for inserting and removing of the modules. The air cooling system is not so effective as a water cooling system used in the basic battery pack. The cooling of the removable battery pack requires information of temperature inside the chamber for battery management system (BMS) and on the basis of external and internal temperature rotational speed of the fans is changed in order to obtain an assumed work temperature. Results of simulation are a part of the work done in the European Integrated Project WP7 "Ostler". The author made a geometry, meshing and calculation for different configurations of the cooling system at different boundary conditions. Fig. 1 presents configuration of cooling system of battery packs (basic and removable) in the electric vehicle. The basic battery pack requires controlling of the fluid flow through the cooling system of different electrical devices such as heater, chiller, cooling plates between modules, inverter, converter DC/DC, and electronic

devices. This system has liquid pump and valve maintaining constant pressure of the liquid. In winter the heating of the electric system is needed, which consumes a big amount of electric energy during start-up.

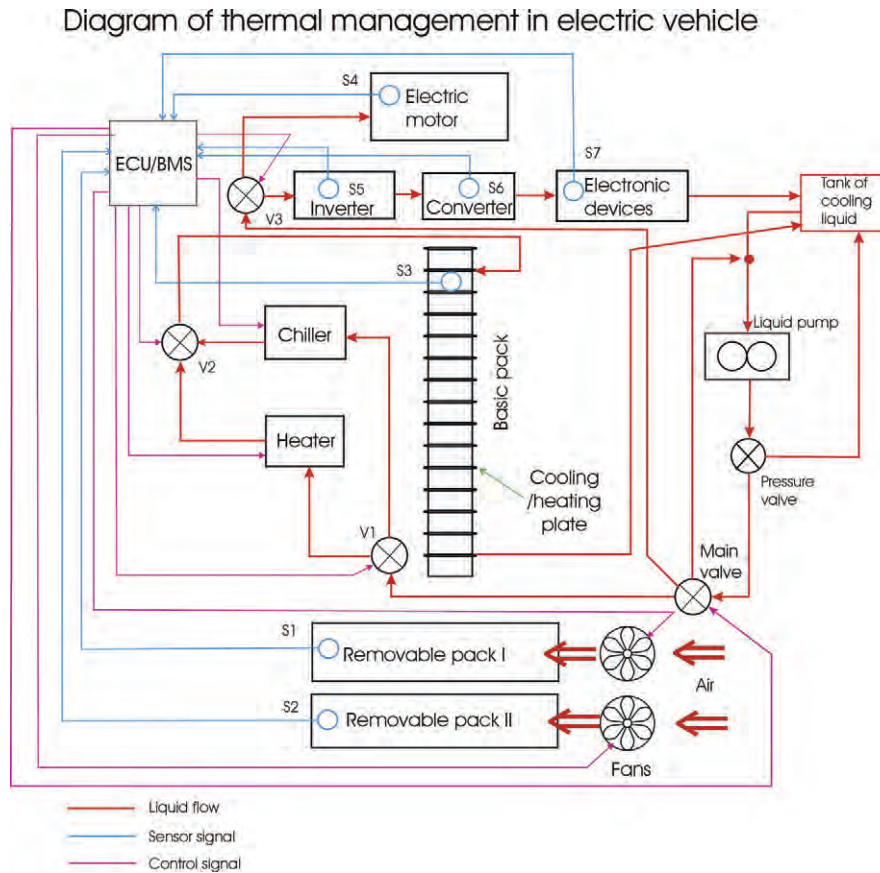

Fig. 1. Diagram of battery cooling management system

Description and work of different battery types is considered by numerous authors for example by Corrigan and Masias [2]. Configuration of battery in electric vehicles was considered by Dhameja [3]. The aim of the study was to define a proper design of the cradle of the removable battery pack in respect to well cooling of the modules by the air with small deviation of their temperature. The other task it was to check influence of inlet velocity of the air flow on temperature of the modules.

2. Geometry of thermal simulation model

Simulation of the air flow inside the cradle and heat transfer between battery modules and the air could be possible by creation of the real geometry in CAD systems. For this project creation of the geometry of the cradle with removable modules was done using the program Catia R19. Using the geometry of the flow space and real geometry of the battery modules the air flow possible to realisation has been computed using Fluent program. The model geometry was creating by inversion of geometry of the cradle with solid walls and solid elements. The outflow connector was begun by rectangular cross-section in the interface with the last module of battery pack and was finished by circular pipe with diameter 50 mm. Two inflow pipes at the bottom with constant diameter 30 mm enable delivering of the air to the spaces between battery modules. The 3-dimensional model of ventilation in the cradle for four modules in the battery pack was created in CatiaR19 system and bottom of the model is shown in Fig. 2 with marking of main elements.

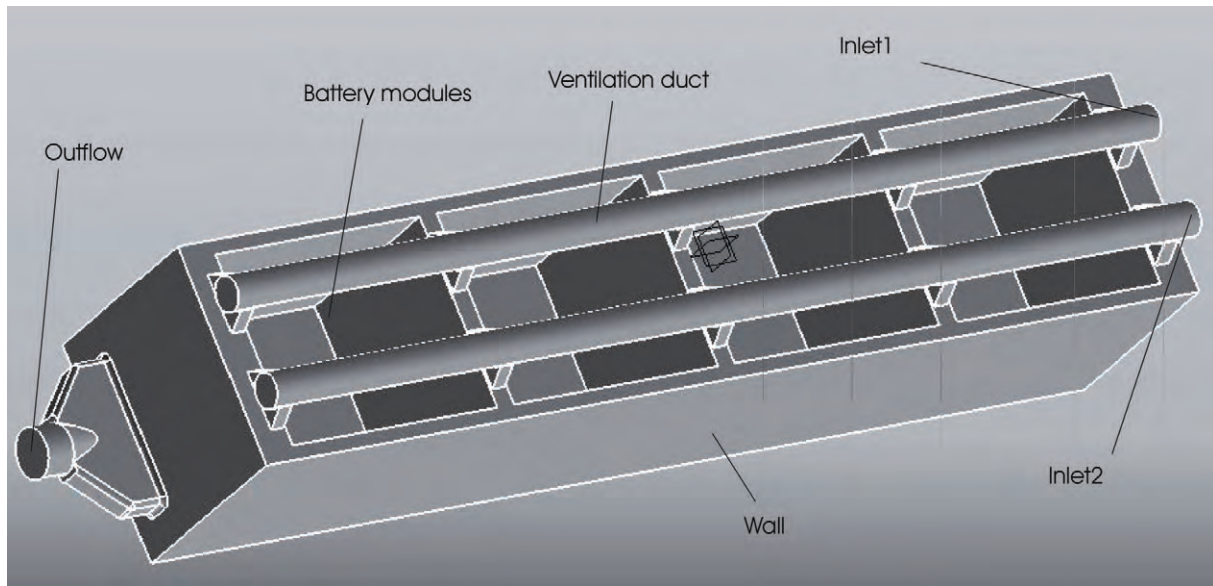

Fig. 2. Flow model of the chamber of the removable battery pack

The 3D model presented in Fig. 2 shows the internal spaces of air flow. Each internal space between battery units is double connected with two pipes. The empty spaces represent the battery modules treated as mass with heat capacity formed during work of battery as a result of internal resistance. For 3-dimensional case of air flow the mesh grid of 3D model, presented in Fig. 3, consists of brick elements. The brick elements are better and faster for gas flow simulation than tetrahedral elements. The 3D simulation model consists of above 500 000 elements.

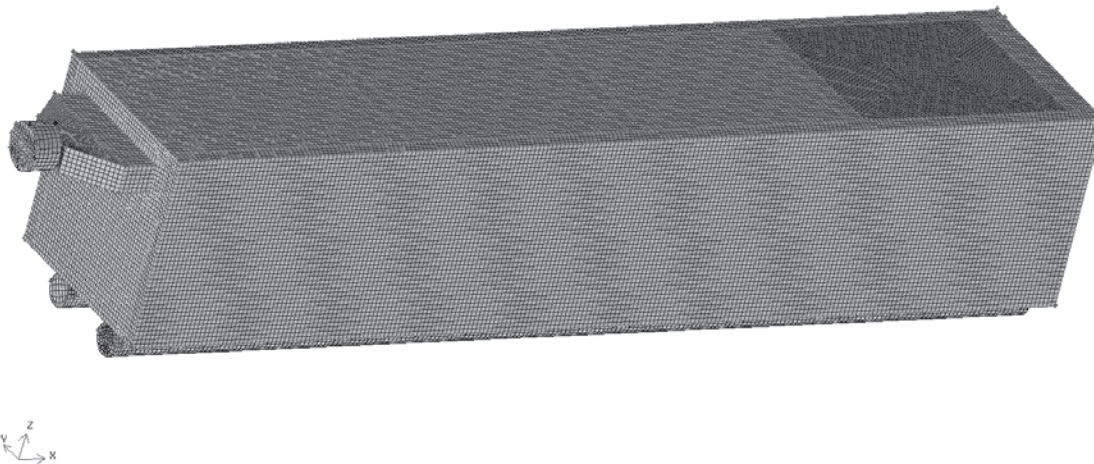

Fig. 3. Brick mesh of the 3D flow model

3. Thermal conditions of battery pack

Modelling of temperature distribution in batteries or battery pack in electric or hybrid vehicles is very complicated because of unknown values of internal resistance during work, however, this problem was highlighted by Jasinski [5], who considered work of lithium-ion batteries. During work the battery loses its durability [6]. Some computer programs enable a simulation of work of electric battery. Ansys-Fluent CFD program has possibility to model work of some battery for example the lithium-ion battery [8].

In the modelling of the thermal condition of the removable battery pack it was assumed a voltage equal $U_1=25.6$ V supplied to each module containing 8 cells. It was considered two kinds of battery: one with ion-lithium and the other with lithium-polymeric cells. The internal resistance

for ion-lithium cells has been equal $R_1=32 \text{ m}\Omega$ and for lithium-polymeric one has been equal $R_2=8 \text{ m}\Omega$. Maximum electric capacity of each module amounts $E_1=1 \text{ kWh}$, which corresponds to power $N_1=1000 \text{ W}$. Each module for both cases causes flow of internal current:

$$I_1 = \frac{N_1}{U_1} = \frac{1000}{25.6} = 39 \text{ A.}$$

Each module generates internal heat equal:

$$Q_1 = R_1 I_1^2 = 0.032 \cdot 39^2 = 51.2 \text{ Ws,}$$

$$Q_2 = R_2 \cdot I_2^2 = 0.008 \cdot 39^2 = 12.8 \text{ Ws.}$$

Heat values correspond to power of the mentioned heat sources: 51.2 W and 12.8 W, respectively.

The ion-lithium battery module generates higher heat power than lithium-polymeric module. However, on the basis of the company information, the first one has almost twice higher durability than the second module.

According to geometrical assumption made in the project each lithium-ion volume of each lithium-ion module of the removable battery pack has been equal:

$$V_1 = W \cdot H \cdot T = 0.193 \cdot 0.197 \cdot 0.260 = 0.00988 \text{ m}^3.$$

For the polymeric-lithium module its volume amounts:

$$V_2 = W \cdot H \cdot T = 0.22 \cdot 0.22 \cdot 0.18 = 0.0087 \text{ m}^3.$$

In such cases volume heat power generated by each module amounts:

$$\dot{Q}_1 = \frac{Q_1}{V_1} = \frac{51.2}{0.00988} = 5182 \text{ W/m}^3,$$

$$\dot{Q}_2 = \frac{Q_2}{V_2} = \frac{12.8}{0.0087} = 1471.3 \text{ W/m}^3.$$

During simulation using 3D model of air flow in the cradle of the removable pack it has been applied the internal heat source equal calculated value of the volume heat power. In the case of 2D model the program has possibility of applying of wall temperature of the battery module equal 350 K.

4. 3D simulation of air flow and heat transfer in the cradle

Simulation of thermal conditions for battery packs with highest load was carried out using computational 3D model and Ansys-Fluent CFD program [1]. Modelling of gas flow besides of mass, momentum and energy balance equations [4] takes into account also turbulence [7]. In simulation of cradle ventilation the conventional κ - ϵ turbulence model was applied. The model assumes the air inflow in the bottom channel with continuous velocity equal 10 m/s and 30 m/s. The outflow was provided at opposite side in upper position. It was assumed inflow temperature equal $T=300 \text{ K}$ and constant battery wall temperature equal 350 K. The mesh grid of brick elements (5 mm length) enables to obtain very precise results of thermodynamic parameters for the air and batteries. Boundary conditions were applied for the inlet side with the flow velocity equal 10 and 30 m/s and turbulence kinetic energy equal $10 \text{ m}^2/\text{s}^2$. The thermal source of battery modules heating was set as equal 4100 W/m^3 , which is lower than was calculated for maximum load (above 5100 W/m^3). Temperature of all walls of the cradle was assumed as 300 K and pressure outflow was set as 101300 Pa with temperature 300 K. Calculation of ventilation and heat exchange in the cradle chamber was carried out for two inlet flow velocities 10 and 30 m/s. Calculation was performed for double precision for steady state flow with 100 iterations. The paper includes only results for inlet velocity 30 m/s for the both pipes.

The same source with heat per unit volume equal 4100 W/m^3 . The target of such calculation was to obtain information about influence of flow velocity on heat exchange between battery modules and the air. For higher inlet velocity the difference of absolute pressure in the space of the

cradle is also of higher value. Absolute pressure amounts from 96200 to 102000 Pa as shown in Fig. 4 for cross section along the inlet pipe.

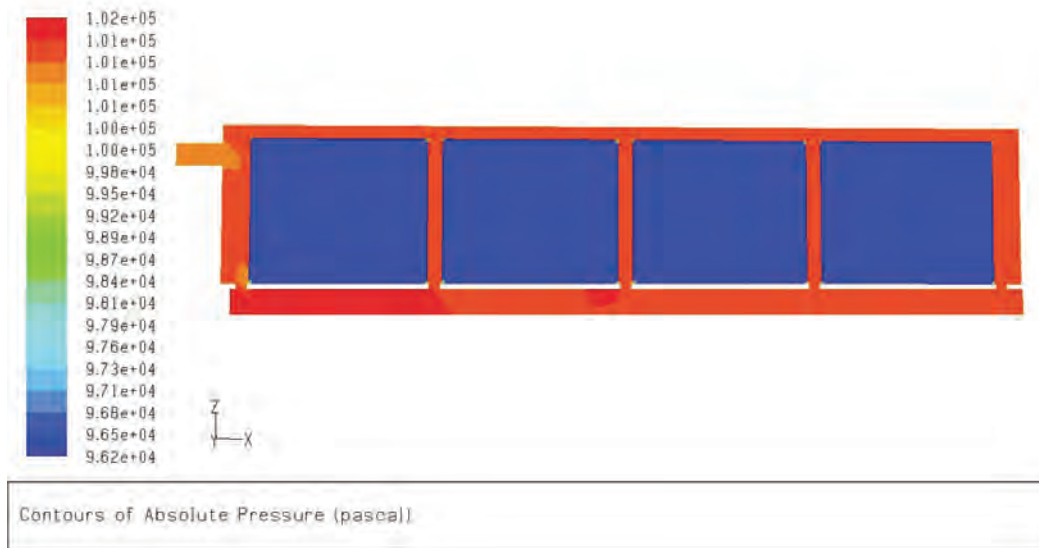

Fig. 4. Contours of absolute pressure in the cross section along the inlet pipe (Pa)

Contours of velocity magnitudes in the cross section of the inlet pipe are shown in Fig. 5. Also for that case the main air flow takes place in the inlet pipe with velocity equal 30 m/s. Maximum velocity reaches value 80 m/s. In the spaces between the modules velocity of the air flow is very low (about 5 m/s). This Figure shows a local increase of velocity in the spaces laying against the outflow channels of the base.

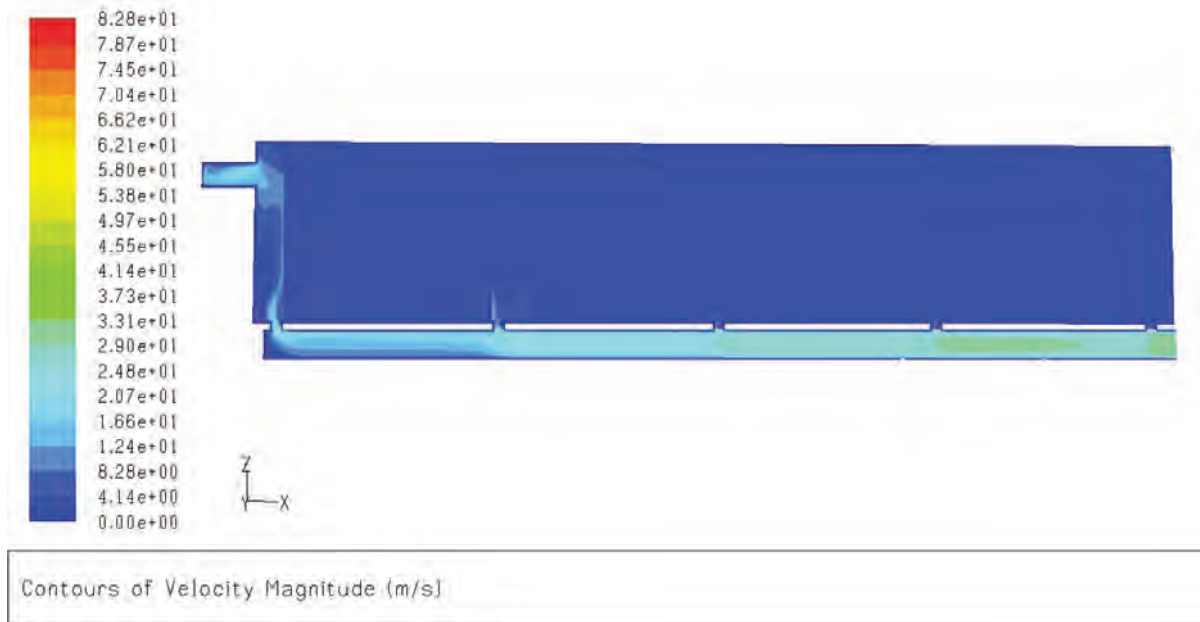

Fig. 5. Contours of velocity magnitude in the cross section along the inlet pipe (m/s)

Better information about the air flow gives distribution of velocity vectors in the cradle space as shown in Fig. 6 at four chosen cross sections. In this case the lowest air flow takes place also in the upper part, where recirculation of the air is observed in the first part of the chamber. There is seen lower velocity between modules, however much higher velocity than in the case with inlet velocity equal 10 m/s, because velocity in these spaces reaches value about 25 m/s. The highest

velocity at the cradle outflow amounts above 80 m/s, which can cause an increasing of the flow noise. Higher flow takes place in the back parts of the cradle space.

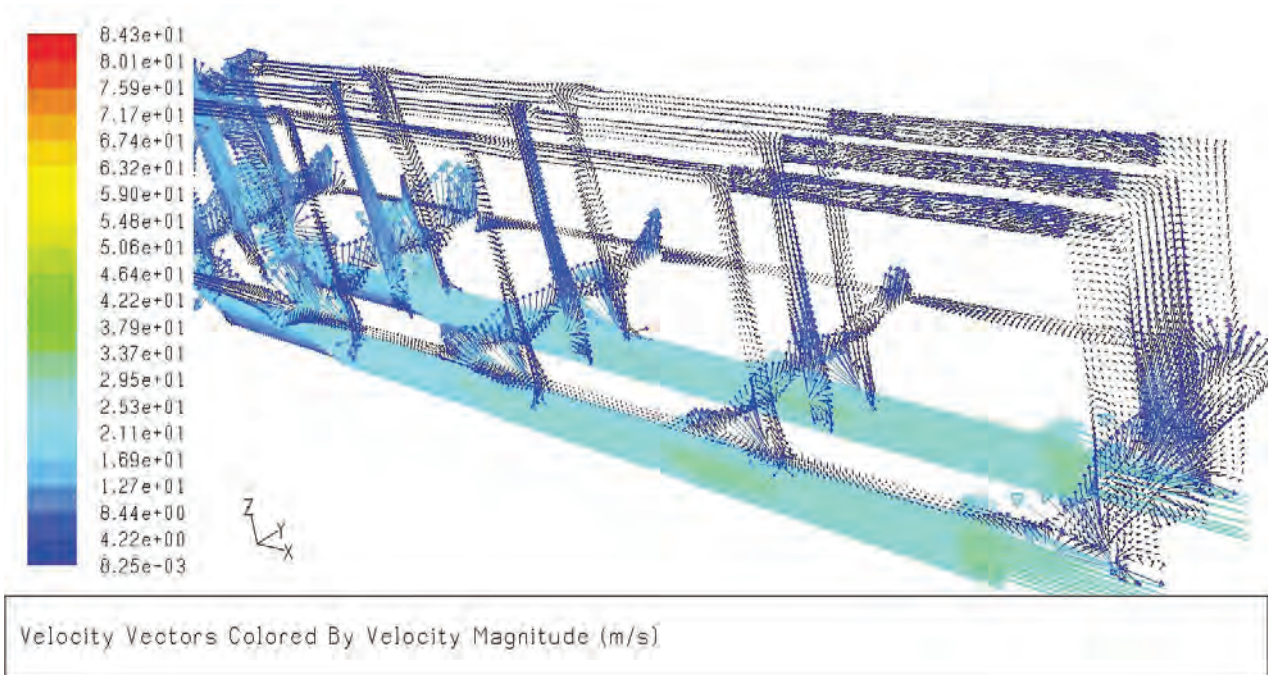

Fig. 6. Velocity vectors in several cross sections (m/s)

Intensity of the flow increases along the cradle from the inlet side to outflow side. Contours of static temperature in the inlet pipe cross section are shown in Fig. 7. Maximum temperature of the first module amounts 315 K and temperature of the last module amounts only 307 K (difference 8 K). In this case temperature of each battery module is much lower than for case with inlet velocity 10 m/s. The maximum temperature of the air reaches value 307 K. For this case the temperature of the modules also decreases with direction of the flow. The highest temperature has the first battery module from the inlet side.

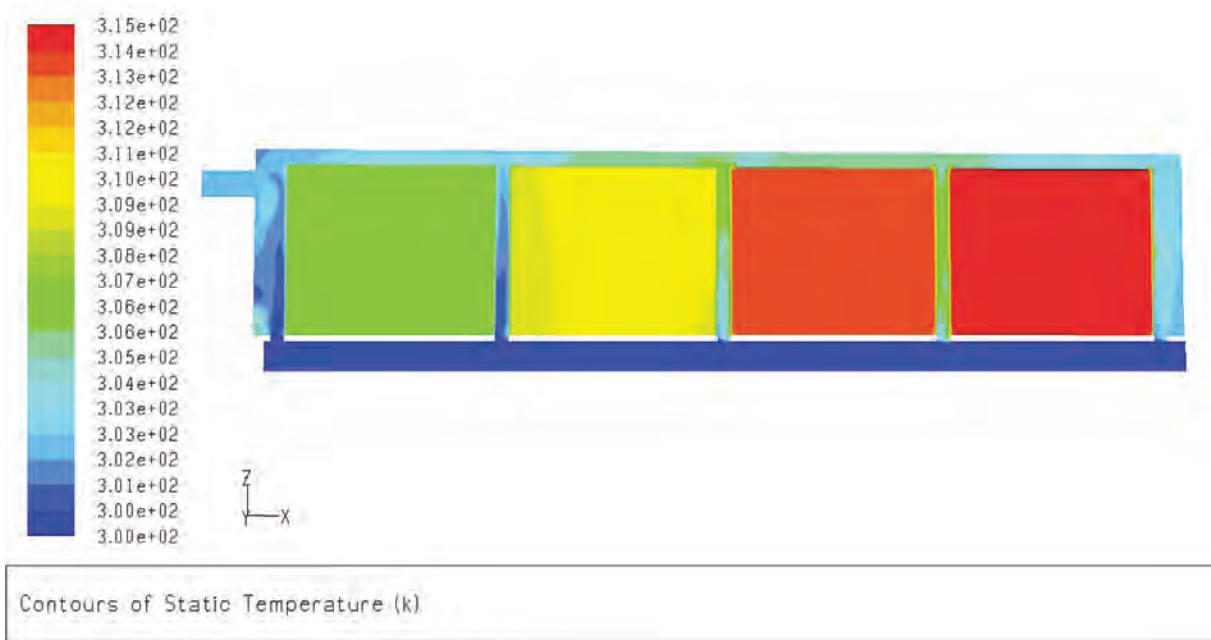

Fig. 7. Contours of static temperature in the cross section along the inlet pipe (K)

The similar variation of temperature is observed in the symmetry cross section for the total temperature. The difference between the static and the total temperature is very small as a result of low dynamic pressure and low inlet temperature 300 K. For better visualization, Fig. 8 shows the temperature distribution of the modules and the air in the lateral cross section. The lowest air temperature takes place in the back sections of the cradle compartment. The temperature of the first module is higher than of the last one because the air tries to flow in the directions with small flow resistance. Around the first module the mass flow rate is less than around the last one.

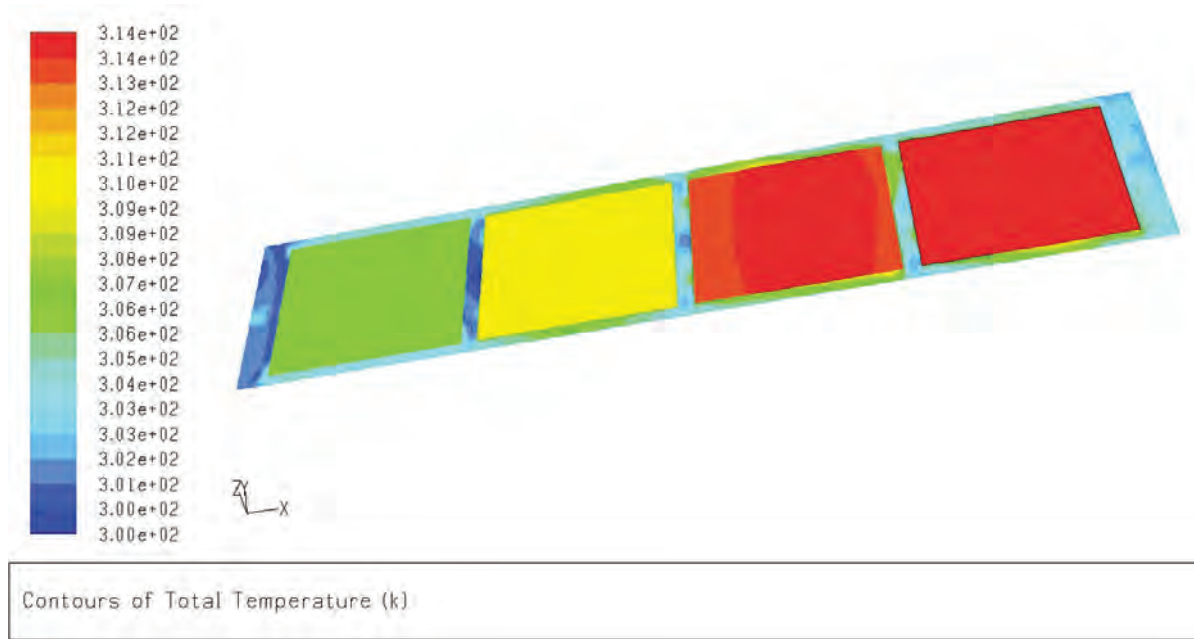

Fig. 10. Contours of total temperature in the lateral cross section (K)

In order to complete the air flow in the cradle chamber the flow turbulence was modelled. One of the most important parameters in turbulent flow is the turbulent kinetic energy. The simulation model took into account k-ε turbulent model with standard coefficient given by computer program. The highest turbulent kinetic energy is formed in the back parts of the cradle space (near outflow side).

Simulation for the case of inlet velocity equal 30 m/s shows better cooling of the battery modules with the lower value of internal temperature than for the case of inlet velocity equal 10 m/s. However the highest velocity can cause an increase of noise at outflow of the cradle.

5. Conclusions

Analyzing of the thermal conditions of the removable battery packs and other devices in electric vehicles one should take into account many factors for stability and durability of those elements. On the basis of carried out analysis of thermal management system and simulation of thermal conditions taking place in the cradle compartment the following conclusions can be introduced:

1. For better control of thermal conditions of battery packs the electronic control should be applied. Temperature signals transferred from the sensors to BMS and analyzed in this unit are the inputs for controlling of mass flow in the cooling system. The system requires several valves for closing or opening cooling passage in dependence on thermal conditions of electric devices.
2. The simplest way of cooling of the cradle compartment of the removable battery packs is applying of air ventilation with one or two air fans.

3. Cooling or heating of the basic battery pack should be fulfilled by using of liquid coolant, which enables more uniform heat transfer from battery modules to coolant.
4. The proposed cooling model of the cradle with air flow caused by fans in the pipe inlet shows that it is not possible to decrease temperature in the same way of each battery modules. It is caused by air circulation in internal spaces of the cradle chamber.
5. Such ventilation solution shows that higher decrease of the battery module temperature takes place for the batteries located near outflow side. It is caused by higher air mass flow rate with lower air temperature. The highest temperature takes place in upper space of the cradle chamber.

Acknowledgment

The work was funded in part by the European Commission within the FP7 Programme in the project Ostler “Optimised storage integration for the electric car” (contract number: FP7-SST-2010-RTD-1) with agreement of all participants.

References

- [1] *Ansys-Fluent User's Guide*, Release 13.0, Ansys Inc., Canonsburg, PA, November 2011.
- [2] Corrigan, D., Masias, A., *Batteries for electric and hybrid vehicles*, Reddy TB (ed) Linden's handbook of batteries, 4th edition. McGraw Hill, New York 2011.
- [3] Dhameja, S., *Electric vehicle battery systems*, Newnes, Boston 2002.
- [4] Hirsch, C., *Numerical Computation of Internal & External Flows*, Elsevier, 2nd Edition, ISBN: 978-0-7506-6594-0, Amsterdam 2007.
- [5] Jasinski, S. A., *Modeling temperature distribution in cylindrical lithium ion batteries for use in electric vehicle cooling system design*, BS Thesis, Massachusetts Institute of Technology, Boston 2008.
- [6] Rong, P, Pedram, M., *An analytical model for predicting the remaining battery capacity of lithium-ion batteries*, Proceedings of design, automation, and test in Europe conference and exhibition, pp 1148-1149, 2003.
- [7] Tryggvason, G., Scardovelli, R., Zaleski, S., *Direct Numerical Simulations of Gas-Liquid Multiphase Flows*, Cambridge University Press, Cambridge 2011.
- [8] Xiao, H., *Battery Thermal Management in Electric Vehicles*, Ansys Inc., Canonsburg 2010.