

MANOEUVRING CHARACTERISTICS OF THE PUSH TRAIN WITH AN AUXILIARY STEERING DEVICE

Teresa Abramowicz-Gerigk, Zbigniew Burciu

Gdynia Maritime University
Morska Street 81-87, 81-225 Gdynia, Poland
tel.: +48 58 5586120, fax: +48 58 5586101
e-mail: tgagerigk@am.gdynia.pl, zbj@am.gdynia.pl

Abstract

The carried out and planned studies on the revitalisation of Odra and Vistula rivers in Poland and restoration of regular inland navigation put a great attention into environmental issues related to the operation of inland waterborne transport means. The design and operational parameters of inland ships and convoys are dependent on waterways dimensions and their influence on the environment. The article presents problems related to manoeuvring performance of the push train, which is the most popular inland waterborne means of freight transport in Poland and in Europe. The alternative auxiliary steering device improving push train manoeuvrability has been tested on the physical model of a push barge. The active bow steering device consisted two bow rotors has the influence on the operational safety of the push train with respect to improved manoeuvring characteristics and decreased impact on the environment, port and lock facilities, ships and boats in narrow passages. The results of model tests presented in the article allowed for estimation of turning ability of the push train with and without bow rotors. A significant difference was observed with respect to the manoeuvring area, distances of advance, tactical diameter, and time of the manoeuvre.

Keywords: inland push train manoeuvrability, manoeuvrability criteria, bow rotor

1. Introduction

The environmental impact of the planned infrastructure necessary for waterborne inland fleet operation along with the impact of expected regular navigation are the subjects of several ongoing and planned studies on revitalisation Polish rivers Odra and Vistula rivers in Poland [1-3, 5, 6]. The special environment protection areas of Natura 2000 network are placed along the rivers on the lengths equal to 70% of the total length of Odra and 30% of Vistula River. Due to this reason, the influence of waterborne inland transport should be studied taking into account natural river processes, river training and previously built locks, bridges and dam constructions.

The possible result of river environment changes like the settlement of new species near the constructions developed by people, restoration of previous habitats when environment is in better condition, changes of migration corridors, restoration fish ladders not available at lower water level should be taken into account in all projects of river infrastructure. Due to the same reason, the impact of inland navigation, which can result with riverbed erosion or lateral bank erosion, should be minimised.

The introduction of a new generation of waterborne inland vessels and push trains is now one of the most important issues together with the implementation of the integrated traffic management and logistic systems [2, 3].

The current waterborne inland shipping of goods in Poland is very limited. The main navigational problems are changing flow rates, small water depths, sandbanks and narrow fairways. The different combinations of pushing-towing units, which are operated on the Middle and Lower Vistula River, are mainly two to four units' combinations of a tugboat, push boat, and standard barges presented in Tab. 1 [12]. The dimensions of convoys are restricted by the dimensions of locks along Gdansk – Warszawa section of E-40 waterway with length and width of

188.37 m and 11.91 m for Przegalina lock, 115.00 m and 12.00 m for Wloclawek. Depths at sills are respectively 3.60 m and 3.50 m respectively. The main dimensions of the barges used in pushing-towing convoys on the Lower Vistula River are presented in Tab. 1.

Tab. 1. Main particulars of the barges used in pushing-towing units on the Lower Vistula River

Main particulars	BP-400	BP-500	BP-1000
Length [m]	35.0	44.0 / 56.0	73
Breadth [m]	8.5	8.0 / 10.2	10.2
Draft [m]	0.7	0.9	0.9

The modern river vessels and push boats are equipped with powerful propulsion and steering units and there is a tendency of increasing the installed power [7]. It is related to better manoeuvrability and at the same time possible destructive impact on riverbed, riverbanks and hydro technical constructions. The introduction of steering devices having limited influence on environment shall be one of the priorities.

2. Influence of propulsion and steering units on river environment and infrastructure

At cruising speeds, the loads induced by propeller thrust streams are not relevant for the stability of riverbed and bank protections. The return flow is the reason that the propeller jet is deflected and does not reach the toe of the bank protection. The area of riverbed affected and the load duration are small [9]. The interactions are much different when a vessel sails under strong lateral wind in narrow waterway sections, under lateral water current and during manoeuvres at low speeds.

There are a number of sources of cross flows in the river, which can generate the hydrodynamic transverse force on the hull:

- wind-induced or tidal drift flows,
- flooding during high water,
- outlet and intake structures from polders,
- groynes and secondary flows in river bends,
- tributary mouths,
- canals,
- harbour entrances in natural waterways,
- entrance areas of locks, circulation zones at lock approaches.

The large windage area, small water depth to ship draught ratio, slow cruising speed, strong wind, local cross flows are the reasons of leeway. The powerful stern rudders allow counteracting the external transverse forces. The counterforce can be produced on the hull at a large drift angle and high speed through the water however; the limited width of the fairway and speed limits related to generated wave loads can cause significant restrictions of the vessel navigation.

The bow rudder can be used if it is effective at high speeds. The most common type of active bow rudder is the four-channel bow thruster. The inlet to the thruster is in the ship's bottom. The sucked water can be accelerated forward for stopping, backwards for pulling and to the port or starboard sides to generate the lateral steering forces. Some of river ships in Europe are equipped with bow thrusters with the power comparable to the main propulsion unit [7], generating jet velocities at the outlet similar to the velocities produced by main propulsion system. The loads from bow thrusters are relevant in narrow waterways during encounters, overtaking and especially during berthing and unberthing manoeuvres.

When a bow thruster is directed towards a wall, the water jet strikes the wall directly; and is deflected from this area in all directions. The physical experiments in full scale and numerical

simulations [3, 7, 8] confirmed that the jet velocity at the bottom is equal to the velocity in front of the quay wall. The loss of velocity during the change of flow direction is negligible and jet influence should be considered for both the wall and bottom. Damages could be severe at the toe of the embankments if banks are protected in the zone of fluctuating water levels only.

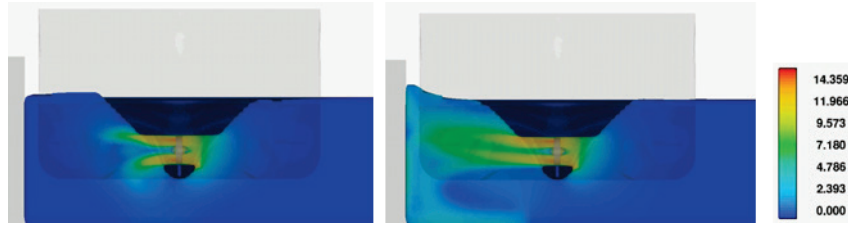

Fig. 1. Bow thruster jet velocities during unberthing [m/s] [8]

The rotating screw of the main propulsion system produces the strongly swirling flow field, which in combination with small dynamic under keel clearance and low ship speed results in significant wash on the riverbed. The modern twin rudder systems can deflect the propeller thrust stream almost orthogonal to the banks; propeller jet can reach higher areas of the bank. The safe distance to protect the banks from thrust streams can be estimated as approximately one vessel beam [7, 10].

There are two empirical methods recommended by PIANC for determination of axial velocity of the jet induced by the bow thrusters. Bot German and Dutch methods should be used as complete design procedures [10], however for inland cargo vessels with full body shapes German method gives more than twice bigger bed velocities than Dutch method [4].

$$U_{\max_bed}/U_o = 2.8 \cdot \left(\frac{z+l}{D_p}\right)^{-1}$$

where:

- U_{\max_bed} – maximum bed velocity,
- U_o – efflux velocity,
- z – distance between the propeller axis and seabed,
- l – distance between the wall and bow thruster outlet opening,
- D_p – bow thruster propeller diameter.

At speeds through the water, over 2 m/s bow thrusters are ineffective. The bow thruster jet is deflected towards the direction opposite to the direction of vessel movement and lateral force is decreasing. In narrow canals when ship sails at slow speed under lateral wind the bow thruster jet can have strong influence on smaller boats.

3. Manoeuvring standards for river vessels an convoys

The manoeuvring performance of a pushed convoy, consisted of a push boat with different configurations of pushed barges should satisfy several requirements, however the generally accepted modern approach to design – design for operation and design for safety lead to the projects taking into account various impacts i.e. influence of wind induced forces resulting in widening of safe manoeuvring area especially important for barges and convoys carrying oversized goods and containers.

The applicable regulations of classification societies [11] based on the manoeuvring standards take into account the following tests:

- maximum speed test,
- stopping test,
- evasive action test,
- turning test.

With respect to Polish Register of Shipping rules [11], the push train manoeuvring characteristics should satisfy the criteria for pushed convoys based on the trials performed in shallow water with the rate of water depth to draft ratio 0.5-1.2.

Minimum speed through the water should be not less than 13 km/h.

Stopping distance over the ground in shallow water for convoy having length (L) and beam (B) equal or less than 110 m and 11.45 m accordingly:

- shall be no greater than 480 m in flowing water with current velocity 1.5 m/s in direction of flow, until speed over ground is 0 m/s,
- shall be no greater than 305 m in standing water.

Evasive action test comprises of four zig-zag trials: 20°/20° and 45°/45° both performed to port and starboard, different rudder angles can be selected for different steering devices. The required turning speed $r_1=r_2$ (Fig. 2) should be 20°/min and 40°/min in 20°/20° and 45°/45° trials respectively. The limit values for time t_4 should be in dependence of water depth 150 s for water depth to ship draft ratio $h/T < 2$ and 110 m in deep water conditions.

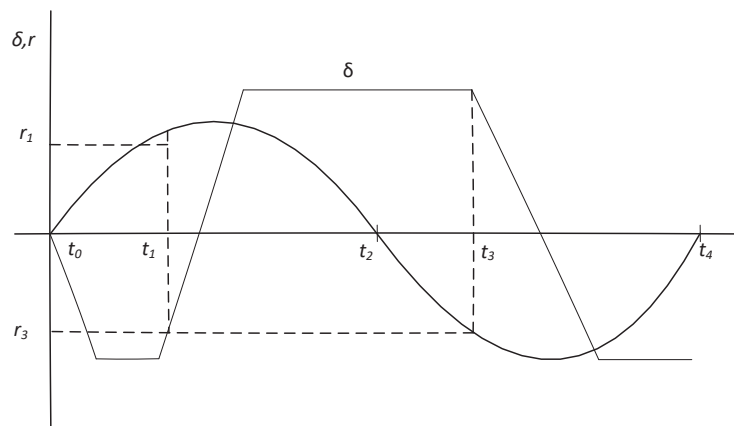

Fig. 2. Diagram of the evasive manoeuvre, δ – rudder angle [°], t_i – time to reach turning speed r_i

Turning capacity shall be proven by turning manoeuvres against the current and it is a subject of manoeuvrability assessment for vessels and convoys with lengths up to 86 m and breadth up to 22.9 m. The turning capacity of longer convoys is not considered in the rules.

3. Manoeuvring characteristics of the push barge with bow rotors

The proposed auxiliary steering device for a push train based on two bow rotors has been tested on the push barge model – push train consisted of the pusher and single barge (Fig. 2), with the main particulars (Tab. 2) related to the current navigational conditions of Vistula River [3].



Fig. 3. Push barge physical model

Bow rotors do not produce strong water jets and can be operated at bigger vessel speeds through the water than bow thrusters.

The previous research has been conducted in order to define possibilities of handling a push

barge on natural rivers and estimate the transverse force generated on the hull by rotor bow rudders [3]. The results of the following model tests allowed estimation of turning ability of the push barge with and without bow rotors (Tab. 3).

Tab. 2. Main particulars of the push barge and push barge model

Main particulars	Push barge model	Push barge
Length [m]	4.966	100
Breadth [m]	0.55	11
Draft [m]	0.06	1.2
Buoyancy [kg]	160	1280000
Model scale [-]	1:20	1:1

Tab. 3. Turning parameters of the push barge model

Parameter	Turning without bow steering system	Turning with bow steering system
Advance	$A_1/L=3.00$	$A_2/L=2.33$
Tactical Diameter	$D_{T1}/L=2.6$	$D_{T2}/L=1.73$

A significant difference was observed with respect to the distances of advance (67 m) and tactical diameter (87) m. The manoeuvring area of the push barge model during turning at the initial speed 0.8 m/s (13 km/h in real scale) and maximum stern rudder angles 35° to port carried out without bow rotors and with bow rotors working simultaneously, advance and tactical diameter reached in both cases are presented in Fig. 4.

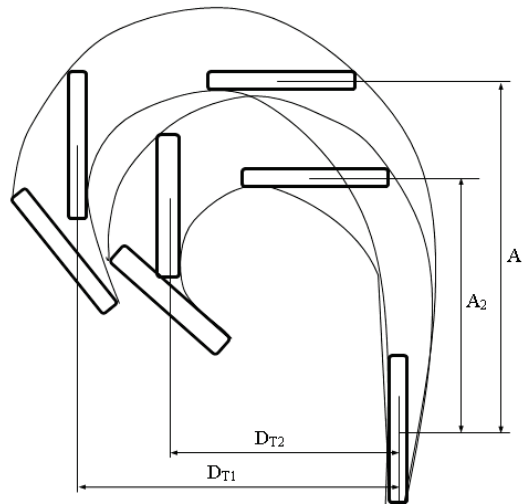

Fig. 4. Turning manoeuvre of the push train, A_1, D_{T1} – advance and tactical diameter of push train with stern rudders, A_2, D_{T2} – advance and tactical diameter of push train with stern rudders and bow rotors

Along the much tighter manoeuvring area the shorter time of the manoeuvre performed with working bow rudders equal to 30 s in real scale has been observed.

The advance of the push boat without rotors equal to 300 m is only a little less than the required stopping distance of 305 m. The use of bow rotors allows decreasing the advance to 233 m. The corresponding difference is equal to half of the push barge length and turning can be used as anti-collision manoeuvre.

4. Conclusions

The presented active bow rudder system consisted of two bow rotors has been tested to decide whether it can give an improvement of push barge manoeuvrability with respect to the safety of navigation. Bow rudders or thrusters are normally used to support steering of convoys during sailing in narrow bends. The passive bow rudders produce very efficient crosswise forces under high speed, the active bow thrusters are mostly used with low speeds, and they produce thrust steams of high velocity, which may destructive impact on environment, hydro technical constructions and users of the fairway. The presented turning trial results confirm the necessity of further research.

Acknowledgement

The research presented in this article has been partly supported by the Regional Operational Programme for the Pomeranian Voivodship for the period 2014-2020: “Smart Specialisation of Pomerania Region program – offshore technology, ports and logistics”; within the frames of the R&D project: RPPM.01.01.01-22-0068/16-00, “Development of a prototype of a system for monitoring the loads on berths and bed protection in the area of ship berthing along with the implementation of the final product on the market by Enamor Ltd. company from Gdynia” within “Smart Specialisations of Pomerania Region – offshore technology, ports and logistics” European program.

References

- [1] Abramowicz-Gerigk, T., Błachuta, J., Burciu, Z., Granatowicz, J., Jacyna, M., Kulczyk, J., Mazurek, M., Nowakowski, T., Picińska-Fałtynowicz, J., Skupień, E., Tubis, A., Werbińska-Wojciechowska, S., Więckowska, M., Winter, J., *Upgrading of Inland Waterway and Sea Ports*, WP5 of European project INVAPO, Gdynia Maritime University, Gdynia 2014.
- [2] Abramowicz-Gerigk, T., Burciu, Z., *The influence of regular river navigation in special protection areas of NATURA 2000 Network*, Journal of KONES, Vol. 23, pp. 9-16, 2016.
- [3] Abramowicz-Gerigk, T., Burciu, Z., Jachowski, J., *An innovative steering system for a river push barge operated in environmentally sensitive areas*, Polish Maritime Research, 4 (96), Vol. 24, pp. 27-34, 2017.
- [4] Abramowicz-Gerigk, T., Burciu, Z., Gorski, W., Reichel, M., *Full scale measurements of pressure field induced on the quay wall by bow thrusters – indirect method for seabed velocities monitoring*, Ocean Engineering, Vol. 162, pp. 150-160, 2018.
- [5] Burciu, Z., Gašior, A., *The analysis of the possibility of revitalization of the Lower Vistula river based on INVAPO European Project*, Scientific Journals of Gdynia Maritime University, No. 92, 2015.
- [6] *EMMA – Enhancing freight Mobility and logistics in the BSR by strengthening inland waterway and river sea transport and promoting new international shipping services*, project funded by the Interreg Baltic Sea Region Programme 2014-2020.
- [7] Heinz, M., Söhngen, B., Doychev, S., Broz, H., Heidenstecker, H., Hüsigg, A., Meyer-Mölleringhof, C., Lohbeck, M., *Driving Dynamics of Inland Vessels Vessel Behaviour on European Inland Waterways and Waterway Infrastructure with Special Respect to German Waterways. Federal Waterways Engineering and Research Institute. Published Federal Waterways Engineering and Research Institute, Karlsruhe*, https://izw.baw.de/publikationen/vzb_dokumente_oeffentlich/0/BAW_VBW_Driving_Dynamics_of_Inland_Vessels.pdf, Germany 2016.
- [8] Jachowski, J., Abramowicz-Gerigk, T., Burciu, Z., Pacholski, M., *Technical Report*, Gdynia Maritime University, Project No. RPPM.01.01.01-22-0068/16-00, 2018.

- [9] Kulczyk, J., Werszko, R., *Influence of ship motion on waterway backward current velocity*, Polish Maritime Research, Special, Iss. S2, 2006.
- [10] PIANC, *Guidelines for protecting berthing structures from scour caused by ships*, Maritime Navigation Commission, Report No. 180, www.pianc.org, 2015.
- [11] PRS Rules, Navigability and manoeuvrability tests of inland waterway vessels and convoys, Polish Register of Shipping, 2010.
- [12] Rabant, H., Habel, M., Babiński, Z., *Transport of the oversized goods on the Vistula waterway, The basic waterway parameters and main difficulties*, Works of Commission of Communication Geography, PTG, 19(3), pp. 7-17, 2016.
- [13] Tabaczek, T., Kulczyk, J., Zawislak, M., *Analysis of hull resistance of pushed barges in shallow water*, Polish Maritime Research 1(51), Vol. 14, pp. 10-15, 2007.

Manuscript received 10 January 2018; approved for printing 20 April 2018

