

Jolanta DRABIK^{a,*}, Rafał KOZDRACH^a, Marek WOLSZCZAK^a,
Janusz MICHALSKI^b, Jerzy JANECKI^b, Grzegorz DUSZYŃSKI^b

^a Institute for Sustainable Technologies – National Research Institute, Radom, Poland

^b PUPH MIND Sp. z o.o.

* Corresponding author: jolanta.drabik@itee.radom.pl

THE VERIFICATION OF QUALITY ENVIRONMENTALLY FRIENDLY GREASE IN EXPLOITATION CONDITIONS

© 2019 Jolanta Drabik, Rafał Kozdrach, Marek Wolszczak, Janusz Michalski, Jerzy Janecki, Grzegorz Duszyński

This is an open access article licensed under the Creative Commons Attribution International License (CC BY)



<https://creativecommons.org/licenses/by/4.0/>

Key words: grease technique, greasing properties, model tests, rheological properties.

Abstract: The article presents the results of grease analyses regarding the assessment of rheological and greasing properties obtained in model tests. The measurement conditions were similar to those in exploitation and related to thermal and mechanical demands. The obtained results confirmed favourable greasing properties and resistance to deformation in the range of temperatures occurring during operation in the conditions of the production cycle. The quality of the grease was verified in the sugar industry after application in the sliding bearing of the screw conveyor. The grease functioned correctly in high-dust conditions of sugar particles throughout the life of the exploitation. The tests have confirmed that the tested grease can be successfully used in such extreme conditions.

Weryfikacja jakości proekologicznego smaru w warunkach eksploatacji

Słowa kluczowe: smar, właściwości smarne, testy modelowe, właściwości reologiczne.

Streszczenie: W artykule przedstawiono wyniki analiz smaru dotyczące oceny właściwości reologicznych i smarnych uzyskanych w testach modelowych. Warunki pomiarów były zbliżone do występujących w eksploatacji, a dotyczyły wymuszeń cieplnych i mechanicznych. Uzyskane rezultaty potwierdziły korzystne właściwości smarne oraz odporność na odkształcenia w zakresie temperatur występujących podczas pracy, w warunkach cyklu produkcyjnego. Jakość użytkowa smaru została zweryfikowana w przemyśle cukrowniczym po aplikacji w łożysku ślizgowym transportera ślimakowego. Przez cały okres eksploatacji smar prawidłowo funkcjonował w warunkach wysokiego zapylenia drobinami cukru. Przeprowadzone testy potwierdziły, że testowany smar z powodzeniem można stosować w tak ekstremalnych warunkach.

Introduction

The safety of food production is one of the biggest challenges facing the food industry. It involves the application of legal provisions regulating the production, processing, storage, transport, and trade of food products [1–3]. Meeting legal requirements in the range of food safety and hygiene is associated with the use in machinery and industrial equipment of high-quality greases with proven ecological values, including those with appropriate certificates confirming their non-toxicity. These requirements apply mainly to the food,

processing, cosmetic or pharmaceutical industries, but also involve the protection of the environment and the use of greases in conditions in which their penetration into the soil and waters is inevitable, e.g., in agriculture [4–6].

The variety of production in the food industry transfers directly into the diverse demands for certified greases, while meeting the technical and operational requirements. The specificity of the food industry requires the use of non-toxic greases in the sphere of food, with parameters guaranteeing the proper functioning of machines and equipment in the food production conditions [7–9].

The analysis of the development trends of the machinery sector for the food industry justifies the need to compose greases with the required the use of functional properties through the precise selection of individual components that enable the production of products that meet stringent environmental and quality standards [5, 6, 10]. Wherever there is a risk of food contamination, components for the production of these materials must meet the highest requirements of the level of certification. Therefore, they should not contain toxic and carcinogenic substances, which results in a limitation in the use of a wide range of ingredients. The applied greases, apart from non-toxicity, should be potentially or completely biodegradable [11, 12].

The greases are an inseparable element of machines and devices, which ensures their proper exploitation. Precise selection of the right lubricant is complex and results from the variety of existing friction joints and their operating conditions as well as the influence of external factors such as temperature, humidity, or pollution. Therefore, the range of requirements for greases resulting from the variety of existing friction joints is very wide, which is important due to the conditions and ensuring efficient work of the devices [8,9].

In addition, the use of greases in the food industry requires the fulfilment of functional criteria. However, it is also conditioned by the fulfilment of requirements in the range health safety confirmed by appropriate certificates. The usable quality of the developed grease was verified in production conditions in the technological process of grinding sugar. Conducting the tests was possible because the product has the required documents, *Safety Data Sheet* and *Health Quality Certificate* issued by National Institute of Public Health – NIH, which was a necessary condition for the admission of this test agent in the food industry in machines and devices.

1. Materials and methods

The subject of the research was a grease developed as part of a research project (*Grease I*). First, tests were carried out in model conditions. The resistance of the grease structure to mechanical forces, and lubricating and rheological properties were evaluated. The grease was then applied to the slide bearing of a worm conveyor. The commercial grease (*Grease Śr*) has been used in this bearing so far, which was successfully replaced with the developed grease due to technical and economic savings.

In the model tests, the resistance of the grease structure to mechanical forces was assessed. Mechanical stability was determined using a roll test using apparatus *Roller tester*. In this test, a sample of grease was rolled between the walls of two rollers of which the inner roller weighing 5 kg was spinning at a certain speed. The principle of measurement in a rolling test consisted

in the evaluation of the change in penetration in given conditions in relation to the penetration before rolling. The measurement was carried out for 4 hours at a set temperature, at a speed of 165 revolutions per minute. In order to obtain information about the mechanical stability of the grease at a given temperature occurring under operating conditions, the tests were carried out at the temperatures of 33°C, 60°C, and 90°C. After the tests the penetration after rolling was assessed. The result is the change in penetration, in percentage, calculated according to the following formula:

$$X = \frac{P_2 - P_1}{P_1} \cdot 100\%$$

where: P_1 – penetration before rolling
 P_2 – penetration after rolling

Anti-wear properties were determined in an hour test carried out under constant load conditions (P) of the friction joint of 392 N at constant spindle revolutions of 500 ±20 rpm and at 20 ±5°C. After the end of the test, the diameter of the blemishes (d) formed on the fixed beads was measured. Then the limit load was calculated from the dependence of $Goz = 0.52 \cdot P/d^2$, which took into account the load of the friction joint (P) and the average diameter of the wear trace (d). The components of the test friction joint and the balls were made of 100Cr6 bearing steel.

The pre-operation tests were carried out on a tester with a friction joint: roller – ring (Fig. 1). The test determined the point of seizing with variable node loads: 10 and 11 kg. The area of the point of seizure was evaluated and the volume consumption and mean seizing diameter were determined.

The rheological properties of the grease were determined using a classic MCR-101 rotational rheometer with an air bearing from Anton Paar. The measurements were performed using a cone–plate measuring system (CP 50–1). The measurements were carried out in the oscillatory mode in the temperature range of 20–120°C with a constant deformation of 0.5% and a constant frequency of 1 Hz. The rheometer control and analysis of measurement data was carried out using software Rheoplus.

2. Results

The rolling tests made it possible to determine the resistance of the grease structure to the mechanical excitation that it is subjected to at the friction joint and during transport to this joint. In this test, the conditions under which grease in bearings operates reflect the actual extortion that the grease is subjected to during operation. The resistance of the grease structure to mechanical force is the basic property determining the greases bearing strength in joints.

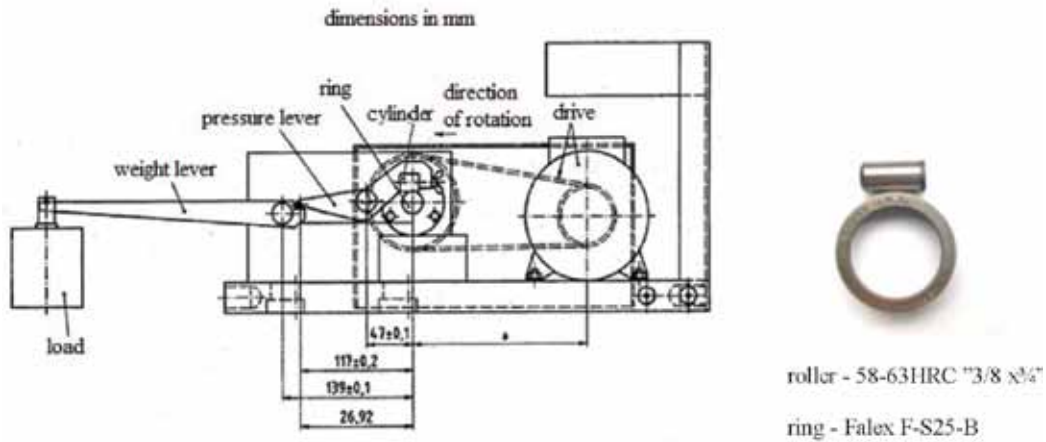

Fig. 1. The scheme of the Brugger device and photo of the friction pair used in the tests

The grease rolling test was carried out at different temperatures to determine the effect of this parameter on their mechanical stability. In the rolling test conditions, a significant influence of temperature on the mechanical stability of Grease 1 was observed (Fig. 2).

At 33°C and 60°C, the consistency of the grease changed from soft to very soft, which resulted in a change in the consistency class from NLGI 2 to NLGI 1. The mechanical stability determined at both 33°C and 60°C was at a similar level, and it was 8.9% and 9.1%, respectively. However, at a higher temperature, there was a definite change in the consistency of Grease 1 from soft to semi-liquid, which resulted in a change in the consistency class from NLGI 2 to NLGI 0. A significant influence of temperature on the mechanical stability of the grease determined in the rolling test was found, while remaining constant measuring conditions, namely rolling time and rotational speed were maintained.

The developed Grease 1 was applied in a sliding bearing of a sugar screw conveyor, where a grease with the consistency NLGI 3 had been used. The working temperature of the slide bearing in which Grease 1

was applied was at 50°C. However, in the conditions of working with the new grease, there was a fear that it could change. Therefore, the mechanical stability of these greases was compared at 90°C (Fig. 3).

Under the rolling test conditions carried out at a maximum temperature of 90°C for 4 hours at a speed of 165 rpm, the grease (Grease_Śr) previously used was characterized by higher mechanical stability than the grease transferred for operating tests. The use of grease in bearings operating at the lower temperatures guarantees their correct operation. In rheological tests, the resistance of the grease to deformation was evaluated in deformation tests. The dependence of the complex modulus (G^*) on the temperature, constant deformation, and frequency was determined (Fig. 4). The complex module is characterized by a conservative module (G') and a viscous module (G'') in the range of the linear elasticity of the grease. In order to compare how the existing grease worked at operating temperatures, the tested greases were subjected to a temperature in the range of 20–120°C, while monitoring the general resistance of greases to deformations caused by these temperatures.

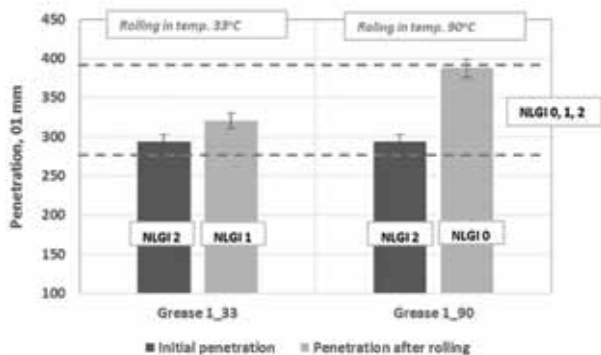

Fig. 2. The comparison of mechanical stability of Grease 1 after rolling. Test conditions: temperature 33°C and 90°C, test duration 4h, rotational speed 165 rpm

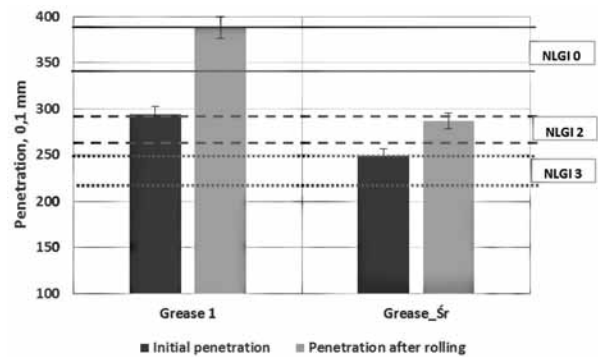

Fig. 3. Comparison of mechanical stability of greases after rolling test. Test conditions: temperature 90°C, test duration 4h, rotational speed 165 rpm

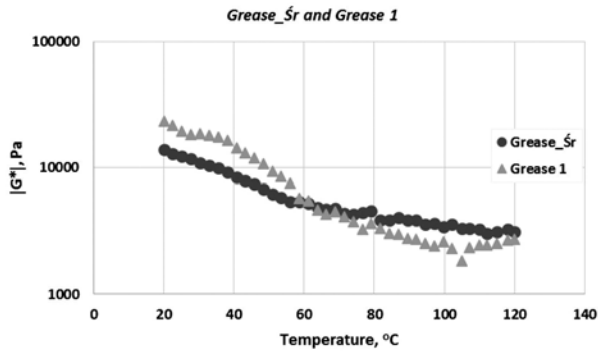

Fig. 4. The dependence of the complex modulus $|G^*|$ of greases on temperature, constant strain and frequency

The estimated working temperature of the slide bearing of the screw conveyor, where the greases were working, was in the range of 33–55°C. The tests confirmed that the developed Grease 1 at the working temperature is characterized by a higher resistance to deformation than commercial grease, which predestines it for application in these conditions. The parameters on the basis of which the level of greasing properties were assessed were the limit value of the wear load $G_{oz/40}$ and the size of the diameter of the wear trace d , after an hour test carried out with a constant load on the friction node (Fig. 5).

The determined wear limit value (G_{oz}) characterizes the anti-wear properties of the grease under boundary lubrication conditions and shows the stability of the created boundary layer. When comparing the properties of the greases evaluated, it can be unequivocally stated that the developed Grease 1 has more favourable anti-wear properties.

The resistance to grease wear (Grease 1) was determined on the research position with friction

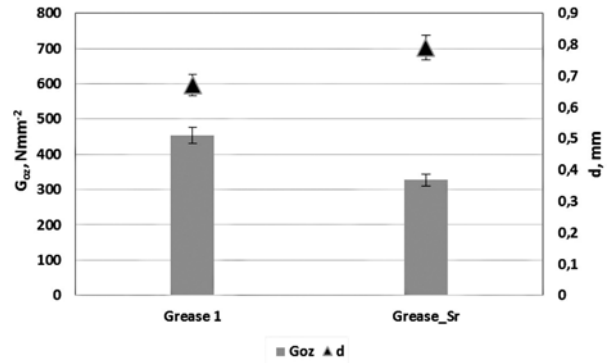

Fig. 5. A comparison of greasing properties of tested greases under constant load conditions – limiting wear of G_{oz} and average diameter of wear trace, d

joint: roller – ring. After the tests, the surface of the cooperating elements was evaluated and the trace of friction was measured on one of the elements, which was the roller. The geometric profilometry was used to analyse the geometric structure of the surface and to evaluate the trace of friction. On this basis, the volume consumption of the trace of friction was determined (Fig. 6a). The interferometric image of the surface of the trace of friction is shown with a load of 10 kg (Fig. 6b).

When analysing the results obtained for Grease 1, it was observed that, after increasing the load to 11 kg, there was a minimal increase in the trace of friction. A load of 12 kg was therefore applied, but this grease no longer carries a higher load. The tests showed that the element grease withstands a maximum load of 11 kg under the test conditions.

After the tests were carried out under the model conditions, tests were carried out on the device selected for carrying out the operation supervised in real working conditions. In the sugar institution in a sugar transporting

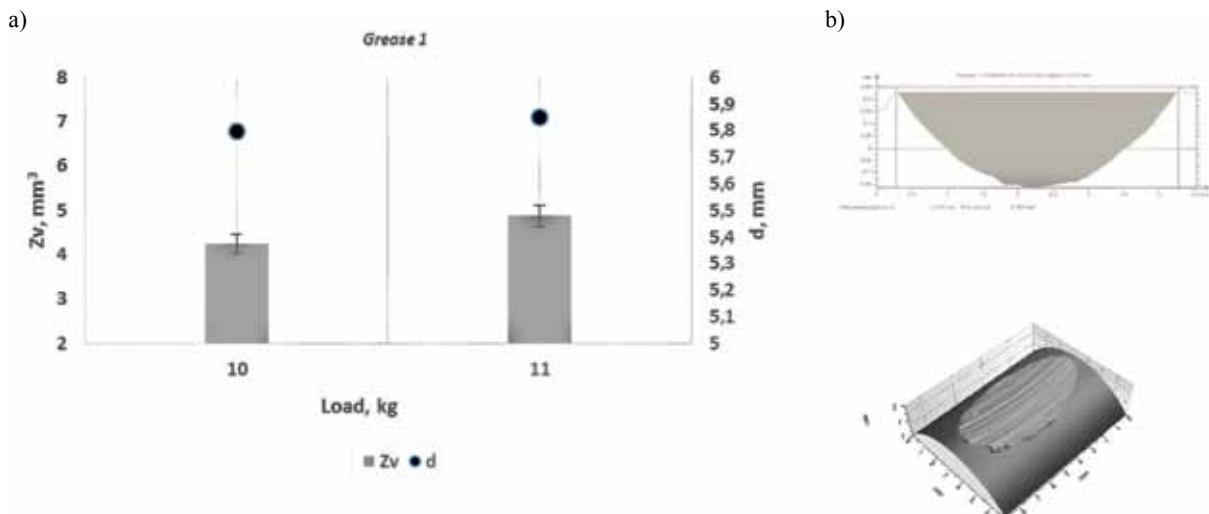

Fig. 6. a) The volumetric consumption Z_v and average diameter of the wear trace (d) of the friction joint element greased with Grease 1, with variable load and b) the profilogram and trace of friction on the surface of the rollers after tests carried out at a load of 11 kg, in the presence of Grease 1

device, the quality of the developed Grease 1 was verified. The monitored operation was subjected to a slide bearing in a screw conveyor of powdered sugar in a mill (Fig. 7). The screw conveyor is supported on three bearings: two external rolling bearings and an internal slide bearing. The test agent was greased with an internal slide bearing placed in the middle part of the screw. The operating conditions of the greased bearings were difficult, because the bearing was exposed to the direct action of dust and small sugar fractions transported by the screw. During the work of the technological line, periodic temperature measurements of friction elements were made.



Fig. 7. The appearance of the slide bearing casing in the screw conveyor with the grease dispenser

The monitoring of the greased slide bearing in the production mode was based on temperature control and the proper functioning of the device. During the operation, there were no symptoms determining the need to replace the grease in the bearing. There was no change in the conditions and disturbances in the correct operation of the bearing. It was observed that, since the change of grease, there was a drop in the temperature of the bearing casing by an average of 25 to 30°C. This indicates that the grease used is functioning properly in such extreme conditions, i.e. high dustiness with sugar crystals. The results of operational tests confirmed its high quality and suitability in this type of application. Based on the previous observation, it was found that the developed grease (Grease 1) can be a replacement for the previously used grease in the slide bearing of the screw conveyor.

Conclusions

The determined parameters in the model tests were adopted as a measure of anti-wear effectiveness, mechanical stability, and resistance to deformation under conditions of mechanical and thermal extortions. The rolling tests carried out under conditions of extreme thermal and mechanical extortion confirmed that the change of the consistency of the grease from soft to semi-solid grease enables trouble-free functioning of the greased bearing, which was confirmed in the operating conditions. The results of rheological tests confirmed the suitability of the grease for a given application, because, in the range of estimated operating temperatures of the friction joint, the grease is characterized by a higher resistance to deformation caused by temperature than the grease that had been used so far. The obtained data from rheological tests can be used for precise selection of grease for a specific application, while taking into account environmental factors.

The correct functioning of the grease was verified in extreme operating conditions in an environment contaminated with dust and sugar crystals. The obtained results of operational tests conducted in production conditions allowed us to assess the impact of environmental conditions on the effectiveness of the grease developed and fully confirmed its high quality and the possibility of using it in such difficult conditions. The developed grease can successfully be a replacement for the previously used grease in the slide bearing of the screw conveyor due to a significant reduction in the bearing temperature, which consequently causes a significant reduction in bearing wear. The introduction of the grease developed on non-toxic ingredients into the lubrication technique will undoubtedly contribute to the increase in the competitiveness of implementing companies.

Project co-financed by the European Union from the European Regional Development Fund under the Intelligent Development Program POIR 04.01.02-00-0004/16.

References

1. *Rozporządzenie (WE) nr 178/2002 Parlamentu Europejskiego i Rady z dnia 28 stycznia 2002r. ustalające ogólne zasady i wymagania prawa żywnościowego, ustanawiające Europejski Urząd ds. Bezpieczeństwa Żywności oraz ustanawiające procedury w sprawie bezpieczeństwa żywności (ze zm.). Dziennik Urzędowy L 031, 01/02/2002 P. 0001 – 0024 (in Polish).*
2. *Ustawa z dnia z dnia 25 sierpnia 2006 r o bezpieczeństwie żywności i żywienia. Tj. Dz. U. z 2010 r.*

- Nr 136, poz. 914, Nr 182, poz. 1228, Nr 230, poz. 1511, z 2011 r. Nr 106, poz. 622, Nr 122, poz. 696, Nr 171, poz. 1016 (in Polish).
3. Van de Sandt P., Carter M., Money C., Pizzella G., van Rijn R., Viinainen R., de Wilde P.: *Human exposure information for EU substance risk assessment of kerosene*. Report CONCAWE, no 6/07, 2007.
 4. Nagendramma P., Kaul S.: Development of ecofriendly/biodegradable lubricants: An overview. *Renewable and Sustainable Energy Reviews*, 2012, 16(1), pp. 764–774.
 5. Bartz W.J.: Ecotribology: environmentally acceptable tribological practices. *Tribology International*, 2006, 39, pp. 728–733.
 6. Beran E.: Effect of chemical structure on the hydrolytic stability of lubricating base oils. *Tribology International*, 2010, 43(12), pp. 2372–2377.
 7. Drabik J., Sitkowska R.: Analiza potencjalnego zapotrzebowania na nietoksyczne smary plastyczne z wykorzystaniem procedury badania tendencji rozwoju produktów. *Prace Naukowe Uniwersytetu Ekonomicznego we Wrocławiu. Innowacje w zarządzaniu*, 2013, 300 pp. 39–46 (in Polish).
 8. Drabik J., Trzos M., Pawelec E., Wrona M., Kozdrach R., Duszyński G., Piątkowski M.: Badanie właściwości użytkowych ekologicznych smarów wytworzonych na olejowych bazach roślinnych. *Przemysł Chemiczny*, 2018, 97(12), pp. 2194–2199. DOI: 10.15199/62.2018.12.38 (in Polish).
 9. Drabik J., Trzos M., Wrona M., Kozdrach R., Wolszczak M., Duszyński G., Piątkowski M.: Modelowanie i ocena właściwości środków smarowych stosowanych w przemyśle spożywczym. *Przemysł Chemiczny*, 2018, 97(12), pp. 2200–2204. DOI: 10.15199/62.2018.12.39 (in Polish).
 10. Studnik H., Hłowska J., Chrobak J., Szmatoła M., Szwach I., Grabowski R., Drabik J.: Badania porównawcze podatności modyfikowanych olejów roślinnych na biodegradację. *Przemysł Chemiczny*, 2018, 97(12), pp. 2136–2140. DOI: 10.15199/62.2018.12.25 (in Polish).
 11. Drabik J., Kozdrach R., Wolszczak M., Wrona M.: Proekologiczne bazy olejowe wysokospecjalistycznych środków smarowych. *Przemysł Chemiczny*, 2018, 97(9), pp. 1538–1541. DOI:10.15199/62.2018.9.30 (in Polish).
 12. Hłowska J., Chrobak J., Grabowski R., Szmatoła M., Woch J., Szwach I., Drabik J., Trzos M., Kozdrach R., Wrona M.: Designing Lubricating Properties of Vegetable Base Oils. *Molecules* 2018, 23, 2025. DOI:10.3390/molecules23082025.