



Various Methods for the Determination of the Burning Rates of Solid Propellants - An Overview

Garima GUPTA, Lalita JAWALE, MEHILAL*,
Bikash BHATTACHARYA

*High Energy Materials Research Laboratory,
Pune-411021, India*

**E-mail: demehilal@yahoo.co.in*

Abstract: The burning rate of propellants plays a vital role among the parameters controlling the operation of solid rocket motors, therefore, it is crucial to precisely measure the burning rate in the successful design of a solid rocket motor. In the present review, a brief description of the methods for the determination of the burning rate of solid rocket propellants is presented. The effects of various parameters on the burning rate of solid propellants are discussed and reviewed. This review also assesses the merits and limitations of the existing different methods for the evaluation of the burning rate of solid rocket propellants.

Keywords: burning rate, composite solid rocket propellant, acoustic emission system, erosive burning

1 Introduction

The composite solid rocket propellant is the major propulsion concept for tactical and strategic missiles/launch vehicles. A composite solid propellant is a heterogeneous mixture of an oxidizer, such as ammonium perchlorate (AP), a binder such as cured hydroxyl terminated polybutadiene (HTPB), a metallic powder as a fuel and some other additives. The ballistic behaviour of a composite solid propellant is influenced by its burning rate. Thus, the burning rate plays a vital role among the parameters controlling the operation of a solid rocket motor [1]. It is therefore very important to measure its burning rate accurately as an aid in the validation of the design of a solid rocket motor. The burning rate

is defined as the linear rate of regression of the propellant, in parallel layers, in a direction perpendicular to the surface itself [2]. In other words, the burning rate is defined as the distance travelled by the flame front per unit time perpendicular to the free surface of the propellant grain, at a known pressure and temperature.

The parameters affecting the burning rate are the pressure in the combustion chamber, the initial temperature of the propellant grain, the composition of the propellant, the particle size of the oxidizer and erosive burning. Apart from this, the inclusion of metal filaments/wires in propellant enhances the burning rates without modification of the chemical composition [1].

Effect of pressure in the combustion chamber

The burning rate (r) dependence on pressure (P) is expressed by the St. Robert's law (or Vieille's law) [3]:

$$r = a \cdot P^n \quad (1)$$

where: r is the burning rate; n is the pressure exponent; P is the pressure; a is the rate of burning constant.

The values of a and n are determined experimentally for a particular propellant formulation with minimum five tests using propellant strands at constant pressure. The burning test has to be performed at minimum three different pressures.

Effect of temperature

The temperature of the unburned solid propellant has a 0.2%/°C effect on the burning rate. Temperature affects the rate of chemical reactions and, thus, the initial temperature of the propellant grain influences the burning rate.

Effect of composition

Huggett [4] suggested that changes in the burning rate caused by changes in composition may be attributed to changes in the flame temperature of the propellant and specific effects which depend upon some physicochemical reactions at some intermediate point in the burning process.

Moreover, the addition of burn rate modifiers such as CuCr_2O_3 , Fe_2O_3 , Cr_2O_3 and CuO in the propellant composition enhances the burning rate of propellant by lowering the decomposition temperature of ammonium perchlorate [5].

Effect of particle size of the oxidizer

The burning rate of propellants that use ammonium perchlorate (AP) as the

oxidizer is affected by the AP particle size. A decrease in particle size of AP increases the burning rate [6, 7].

Effect of erosive burning

High velocity combustion gases which flow parallel to the burning surface lead to an increase in burning rate. The velocity-dependent contribution to the burning rate of a solid propellant is referred to as erosive burning, and affects the performance of solid rocket motors [8].

Various physicochemical parameters, such as cross flow velocity and pressure of gases, threshold velocity, initial temperature of the propellant, normal burning rate, presence of metals, particle size of oxidizer, size of rocket motor, etc. also have an effect on erosive burning [8].

Effect of cross flow velocity and pressure of gases

The total burning rate increases with increases in both pressure and cross flow velocity.

Effect of threshold velocity

Augmentation of the burning rate of a solid propellant is observed only when the velocity of the combustion gases is greater than a certain threshold value.

Effect of initial temperature of the propellant

The erosive burning rate increases with increases in the initial temperature and temperature sensitivity of the propellant [9]. However, it also depends on the composition of the propellant.

Effect of normal burning rate

Propellants with a lower burning rate experience greater erosion than those with a higher burning rate.

Effect of the presence of metal

Addition of metal has very little effect on erosive burning.

Effect of oxidizer particle size

Erosion increases with an increase in the particle size.

Effect of rocket motor size

A decrease in the port diameter makes a rocket motor more sensitive to erosive burning.

Consequently, for the validation of a propellant, the burning rate is a very important parameter and its determination involves small-sample testing in the laboratory, subscale motor firings and finally full-scale firings at established test facilities.

In the following section, a detailed literature survey of the determination of the burning rate of a solid propellant, using different techniques, along with the methods for the determination of the erosive burning rate, have been reviewed. The advantages and limitations of each method are also highlighted.

2 Experimental Methods Employed for the Determination of Burning Rates

2.1 Crawford bomb method

This technique was developed by Crawford and co-workers [10] in 1947 and later modified by Grune [11]. In this method, fuse wires are embedded through the propellant strand at accurately measured distances, as shown in Figure 1. The propellant strands having diameter 3 mm are inhibited to exhibit only end burning. The inhibition is carried out by dipping the propellant strands into inhibiting material consist of epoxy resin, epoxy hardener, diluents and antimony oxide and taken out. After this, the inhibited strands hanged in air for curing. The fuse wires are connected to an electronic timer and the strand is mounted in a closed chamber pressurized by an inert gas like N_2 . The desired constant pressure in the bomb is maintained during combustion by the use of a large surge tank of inert gas. The propellant is ignited at the top by means of a hot wire and the burning rate is calculated from the distance between the wires and the elapsed burning time between the fuse wires. An error of about 2-3% in the burning rate measurement using the Crawford bomb has been reported [12]. Further to this, Akira *et al.* [13] developed a modified Crawford method by replacing the fuse-winding with two phototransistors placed a predetermined distance apart along the rod-like sample, in order to determine the linear burning rate of a solid propellant in an inert atmosphere.

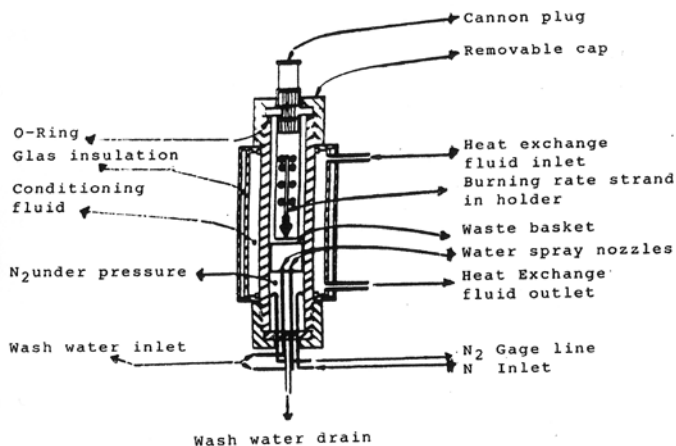

Figure 1. Crawford bomb for the measurement of burning rate [8].

However, it is not possible to maintain the gas flow as encountered in rocket motors. This method is very tedious due to the need to inhibit the propellant strands.

2.2 Closed vessel technique

In this method, the pressure variation is measured against time. The pressure is allowed to build up thereby accelerating the combustion. A schematic diagram of the closed vessel technique is depicted in Figure 2. The pressure is recorded as a function of time. The burning rate (r) is calculated using the following correlation [14]:

$$\ln (dP/dt) = \ln (q a_1 / LC_p T_o) + (1+n) \ln P \quad (3)$$

where:

L is the length of the cylindrical sample; q is the heat of combustion (cal/g); n is the number of moles of the gas; a_1 is a constant, and C_p is the specific heat. A plot of $\ln (dP/dt)$ v/s $\ln P$ gives a straight line and a_1 is calculated from the intercept $\{\ln (qa_1/LC_p T_o)\}$, since the other parameters, viz; q , L , C_p and T_o are known.

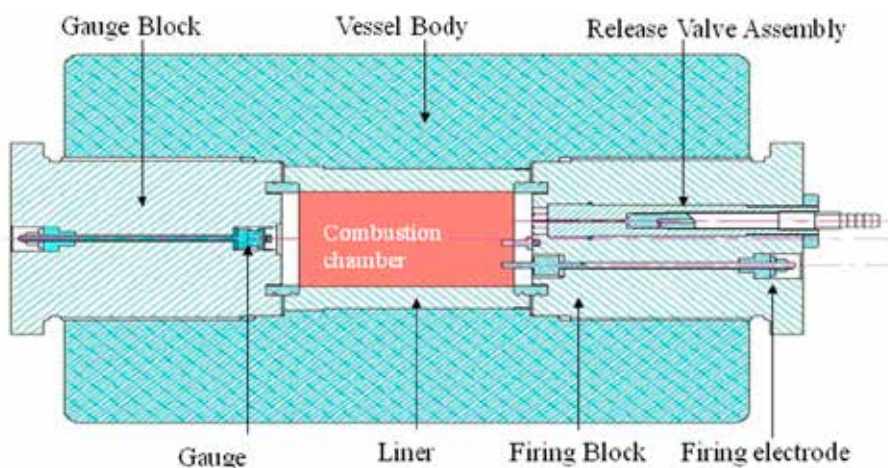

Figure 2. Closed vessel set up for the measurement of burning rate. (HEMRL, Pune, India).

To further upgrade the closed bomb technique, Lui [15] has used the advantages of a conventional Crawford bomb and successfully measured the direct burning rate of the propellant, while Richard [16] has utilized the principle of microwave interferometry in a closed bomb to measure the burning rate of the propellant. However, this method only provides an average burning rates over a given pressure interval [17].

2.3 Ultrasonic measurement techniques

An ultrasonic technique measures the burning rate as a function of pressure in a single test which is carried out at constant volume [18]. A schematic diagram of an ultrasonic testing setup [19] for the measurement of the burning rate is represented in Figure 3. In this set up, the burning chamber is called a closed bomb, and contains the tested propellant sample having length 35 mm with diameter 30 mm [20] and attached to a coupling material. An ultrasonic transducer is attached to the coupling material which emits a mechanical wave that travels through the tested material and is reflected at the burning surface and returned back to the transducer [21].

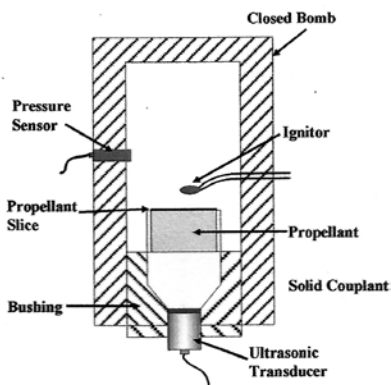

Figure 3. A schematic diagram of the ultrasonic technique for the measurement of burning rate [17].

Later, Kelichi *et al.* [22] modified the ultrasonic method for the measurement of the burning rate of propellants by making use of the Doppler effect and Wavelet analysis in an electronic device. In the modified version, an ultrasonic signal is emitted from the ultrasonic sensor, which is directly attached to the metallic combustion chamber and propagates through the chamber wall. The ultrasonic signal is reflected from the burning surface and subsequently the ultrasonic sensor receives the signal. The frequency of the observed signal deviates from the original one due to the Doppler effect, as the burning surface of the propellant sample is moving towards the sensor. This change in frequency is analyzed by the Wavelet method and the instantaneous burning rate is obtained using the sonic speed within the propellant sample. Although, the proposed method requires experience, this is expected to be useful for measuring the burning rate of propellants in full-scale motors.

A review on the development of the ultrasonic technique for precisely measuring the instantaneous regression rate of a solid-rocket propellant under transient conditions has been reported by Jeffery *et al.* [23]. The technique was used to measure the burning-rate response of several solid propellants to an oscillatory chamber pressure. This measurement is known as the propellant's pressure-coupled response function and is used as an input into rocket stability prediction models. The ultrasound waveforms are analyzed by cross-correlation and other digital signal processing techniques to determine the burning rate. Digital methods are less prone to bias and offer greater flexibility than other previously used techniques.

To further improve the ultrasonic technique, Song *et al.* [24] developed a laboratory prototype system that can acquire 800 sets of complete ultrasonic

waveforms and pressure data in a second. However, this prototype system has limitations in its data acquisition and processing capabilities. Therefore, a dedicated, high speed system that can acquire complete ultrasonic waveforms and pressure data up to 2,000 times per second was developed [19]. The system can also estimate the burning rate as a function of pressure using special software based on complete ultrasonic waveform analysis. Also, the ultrasonic pulse-echo technique has been applied for the measurement of the instantaneous burning rate of aluminized composite solid propellants by Desh *et al.* [20]. The tests have been carried out on end-burning, using propellant specimens of having length 35 mm and diameter 30 mm at a constant pressure of about 1.9 MPa. The burning rates measured by the ultrasonic technique have been compared with those obtained from ballistic evaluation motor tests of composite propellant from the same mix. An error of about $\pm 1\%$ in the burning rate measurement by the ultrasonic technique has been reported.

Ultrasonic measurement devices are expensive, time consuming and only an experienced dedicated person in interpretation of results is capable of performing the experiment.

2.4 Microwave techniques

Another method of burning rate measurement is the microwave technique, which is based on microwave reflection interferometry. In this method, a propellant sample having length 8-9 mm and diameter 8 mm [25] is bonded in a circular tube, known as a propellant filled waveguide, as depicted in Figure 4, and linked to a burner chamber pressurized with nitrogen by an oscillatory pressurization system. The microwave signals propagate through the propellant strand and are reflected from the propellant burning surface. The phase shift in the reflected signal is continuously measured and from this shift the burning rate of the propellant sample is obtained [26].

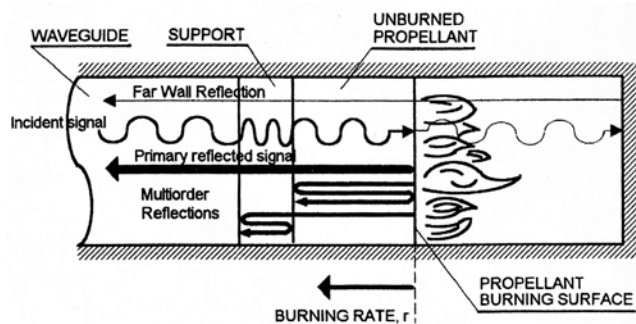

Figure 4. Microwave technique for the measurement of burning rate [29].

Johnson [27] and Wood *et al.* [28] have reported measurements of the burning rate using the microwave technique in 1962 and 1983, respectively. Furthermore, Kilger [29] simulated this type of measurement to illustrate the distorting effect on the calculated burning rate due to additional time-varying reflections. O'Brien *et al.* [30] described a multiple reflection theory for microwave measurements of solid propellant burning rates, and Boley improved the data reduction to predict the burning rate using the microwave properties of the materials [31].

Bozic *et al.* [32, 33] presented a new measurement system for direct and continuous measurement of the instantaneous burning rate of solid rocket propellants at different pressures and different gas flows over the burning surface, based on microwave transmission interferometry. The system consists of an experimental motor, microwave installation, hardware, and special software for data reduction. The burning rate is calculated through the software immediately after the test runs. The error in the measurement of the burning rate by the microwave technique is about 1.25%.

A dual frequency microwave-based burning rate measurement system for solid rocket motors was also developed by Foss *et al.* [34], based on two independent frequencies operating simultaneously, to measure the instantaneous burning rate. Computer simulations and laboratory testing were performed to determine the ability to limit the errors caused by secondary reflections and uncertainties in material properties, and indicated that the system can provide a 75% reduction in error over a single frequency system.

The microwave technique is expensive and extensive training is needed for smooth operation of the instrument.

2.5 Real time X-ray radiography

The basic configuration for real time radiography (RTR) includes an X-ray source and an RTR imaging system as shown in Figure 5. The X-ray source consists of a control unit, a pulse forming network, a radio frequency (RF) power source, a linear accelerator and an RTR imaging system equipped with an X-ray screen which converts X-ray to visible light. The surface mirror and low light level silicon intensified target (SIT) cameras convert the visible light to video signals. The image produced by the X-ray system is interpreted to determine the propellant surface position [21, 35].

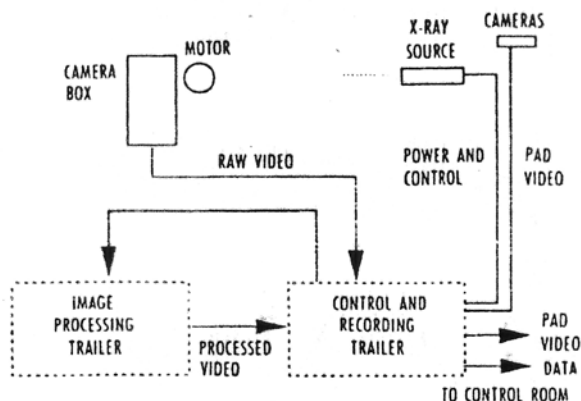

Figure 5. Real time radiography system for the measurement of burning rate [32].

Masahiro *et al.* [36] described a non-intrusive X-ray diagnostic system to calculate the burning rate in solid rocket motors having a rectangular cross section and loaded with two solid propellant slabs parallel to each other, consisting of ammonium perchlorate 68, hydroxyl-terminated polybutadiene 12, aluminum powder 20 wt.%, with 0.3-0.5 wt.% Fe_2O_3 as a combustion catalyst.

Osborn and Bethel [37] used Pb-Sb (98.5/1.5%) wires (0.0045 in., m.p. 327 °C, thermal diffusivity 0.25 cm^2/s , at 100 °C) embedded in a specimen of solid propellant to form a resistance wire network. The distances between the wires were determined from an X-ray picture of the specimen prior to bonding it to the propellant in a rocket motor. The burning rate was calculated from these distances and resistance vs. time curves. The burning rate and flow field are not affected by this method, which can be used to study the influence of the port shape of a propellant grain inside a rocket motor on the burning rate.

This technique is expensive and cumbersome steps are involved in its operation. There are also personnel hazards associated with X-rays as it requires high power (320 kV at 10 mA) with intensity in the range of 100 eV to 100 keV [38]. Moreover, this technique has limitations in terms of spatial resolution and accuracy [20].

2.6 Plasma capacitance gauges

Another well-known technique for the determination of the burning rate of a propellant sample is the plasma capacitance gauge, which is based on the variation of electrical capacity with time and is directly related to the thickness of the material between two electrodes. The first electrode is located along

the case of a solid rocket motor and the second electrode is formed by the plasma generated from the combustion gases. The capacitance increases as the thickness of the insulator decreases. These data yield real time information on the insulation thickness and behaviour, which subsequently reveal the occurrence of the flame arrival [21]. A schematic diagram of the PCG technique [39] is depicted in Figure 6.

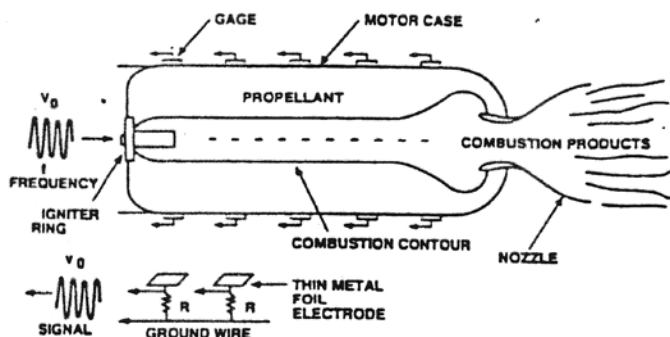

Figure 6. Plasma capacitance gauge technique for the measurement of burning rate [34].

The fundamental advantage of this technique is that it can be measured through materials which X-rays and ultrasonic waves have difficulty in penetrating.

The PCG technique has been used mostly for the measurement of insulation erosion [40].

2.7 Optical techniques

2.7.1 Chimney type strand burner

The strand burner with a gas flow system is called a chimney type of strand burner (Figure 7). It consists of a chamber with four quartz windows mounted on the side of the chamber wall. A small cylinder of 20 mm diameter is mounted vertically inside and connected to the base of the chamber. Four transparent glass plates are mounted on the side of the cylinder. Nitrogen gas is passed through the base of the chamber and the flow rate is adjusted by changing the size of the orifice mounted on the top of the burner. Photographs of the combustion wave structure in the gas phase are obtained using a high-speed video camera. The propellant strand is illuminated from the outside of the strand burner by a tungsten/xenon lamp in order to observe the burning surface. The micro-photographs of the

burning surface are obtained by a micro-telescope mounted on a high speed video camera [41].

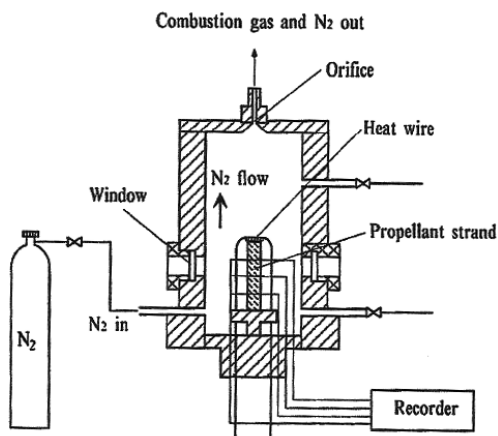

Figure 7. Chimney type strand burner with observation windows [37].

Reese *et al.* [42] evaluated the combustion of a propellant in an optically accessible combustion vessel under quiescent nitrogen gas. The combustion progress was evaluated using a high speed video camera. Osborn *et al.* [43] described the photographic measurement of the burning rate in solid rocket propellant motors by photographing the moving surface of the burning propellant, computing the distance burned from a sequence of photographs and the measured combustion chamber pressure.

Further to this, Eisenreich *et al.* [44] reported an optical system for measuring the burning rate of a solid propellant strand using a bomb equipped with quartz windows, an objective, a photo diode array and a data acquisition and processing unit. The pressure dependence of the burning rate of propellants was evaluated. The results are comparable with those obtained by the standard Crawford method. The advantages of the optical system are the ease in handling the sample preparation and assessment of the distribution of the burning rate.

The technique is direct, does not disturb the flow field of the combustion gases or influence the heat-transfer characteristics of the propellant, and is extremely rapid (<0.2 s.) with an error of $\pm 3\%$, but sorting out the data is tedious and time consuming [43].

Moreover, it is also essential to maintain the flow of nitrogen gas around the burning strand in order to avoid the deposition of smoke on windows for better clarity [41].

2.7.2 Laser techniques

Wang *et al.* [45, 46] developed a laser technique for the measurement of transient burning rates of solid propellants during oscillatory combustion and rapid depressurization, respectively. In this method, a He-Ne laser is used as a light source which is projected across the propellant's top surface and focused on a photocell through a regulator. The photocell detects a laser beam passing through the propellant strand and the cross-section of the laser beam is regulated via the regulator. The laser energy signals are converted to voltage and further passed through an amplifier followed by a light beam oscilloscope. A schematic diagram of the laser technique is represented in Figure 8.

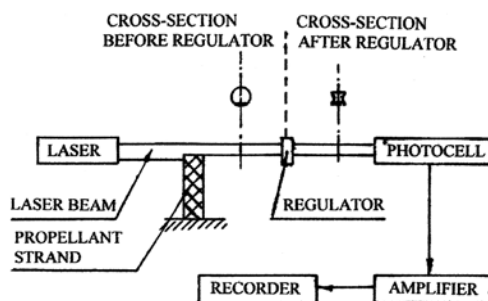

Figure 8. Laser technique set up for the measurement of burning rate [41].

The laser energy varies linearly along the height of the strand. The burning rate is calculated from the following equation:

$$r = (-1/k) \cdot (dV/dt) \quad (4)$$

$$k = -V_0/H_0$$

$$r = (H_0/V_0) \cdot dV/dt \quad (5)$$

where:

r is the transient burning rate; k is the system constant; V_0 is the total voltage shift calculated from the recorded graph voltage vs. time; H_0 is the diameter of the laser beam.

2.8 Acoustic Emission System (AES)

The burning rate of a solid propellant as a function of pressure is extensively measured by an acoustic strand burner [1]. An acoustic emission technique, with 94% accuracy for the determination of the burning rate of multibase propellants at high pressure, has been reported by Caveny *et al.* [47]. This method is used

for rapid assessment tests or quality control of large propellant production based on composite propellants [48].

Principle

Acoustic emission testing is a powerful method for examining the behaviour of materials deforming under stress. An acoustic emission may be defined as a transient wave generated by the rapid release of energy within a material as sensed by a piezoelectric transducer. The signal passes through a preamplifier and post amplifier and recorded on an oscilloscope. A schematic diagram of an acoustic emission system is presented in Figure 9.

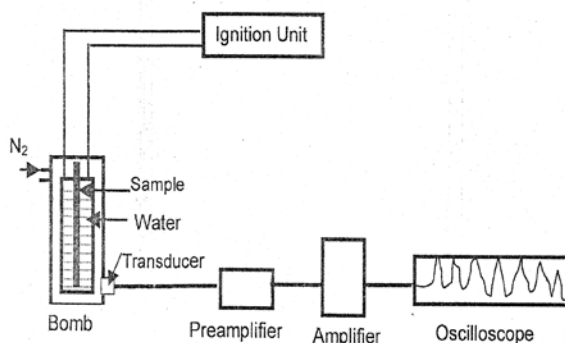

Figure 9. An acoustic emission system for the measurement of burning rate.

Equipment: An acoustic emission system comprises following units:

- (i) **Bomb:** The bomb is made of stainless steel (SS 316) having total height 329 mm, outer diameter 126 mm and inner diameter 62.27 mm. The total volume of the bomb is 730 mL, of which 550 mL is filled with water during firing. It consists of a panel made of insulating material, for mounting the propellant strand. The transducer is mounted on one side of the bomb with a flat smooth surface, while electrical connection is provided through the upper lid.
- (ii) **Transducer:** An acoustic transducer of 200 kHz resonance frequency is used.
- (iii) **Preamplifier:** The transducer is attached to a preamplifier with the help of accelerometer cable having a 200 kHz octave band width filter. It is used to avoid attenuation in gain due to the long connection cable.
- (iv) **Post Amplifier:** This amplifies and filters the incoming AE signals from the preamplifier for analysis.
- (v) **Oscilloscope:** Signals are recorded on an oscilloscope having a band width of 500 MHz.

- (vi) Ignition unit: This is used to fire the sample at 18 V and 2 Amp current using 37 standard wire gauge (SWG) Nichrome wire.
- (vii) Nitrogen cylinder: This is used to create the required pressure in the combustion chamber/bomb.

Procedure

The propellant strand of known dimensions (6×6×150 mm) is mounted on a panel board with the help of Nichrome ignition wire and kept inside the bomb partially filled with water. The bomb is pressurized with nitrogen gas at the required pressure (25 kg/cm² to 200 kg/cm²). The strand is ignited electrically by the firing unit. The acoustic emission (AE) wave generated due to the propellant burning in water is sensed by the acoustic emission transducer. The electrical signal is sequentially passed through the preamplifier and the post amplifier to the oscilloscope and the burning rate is calculated from the recorded graph.

This method has numerous advantages including low cost, a more accurate pressure value, and more reliable and accurate results. It avoids complex wiring, inhibition of the strands and sample preparation, and thus helps to improve the precision and accuracy of the measurement. Furthermore, coupling material is not required as in the ultrasonic method which measures the burning rate in a wide range of pressure values. The acoustic emission system is a superior tool for measuring statistical effects in small formulation changes for quality control work and is used as a regular method for burning rate measurement of propellant strands in full-scale motors [49] with ±2% measurement error.

3 Determination of Burning Rates for Subscale Motors (2 kg to 40 kg level)

3.1 Thickness/time (TOT) rate

In this technique, the burning rate is determined directly based on the fundamental equation:

$$r_{\text{TOT}} = \text{web thickness/burning time} = W_E - W_B/t_E - t_B = W_b/t_b \quad (6)$$

where:

W_b is the web thickness; t_b is the burning time.

3.2 Mass balance (MB) rate

Brooks [50] and Whitney *et al.* [51] have developed a new technique for the

measurement of the burning rate using a mass balance equation based on some approximations. The burning rate is calculated, indirectly, from the mass balance between the input from the burning propellant grain and the output through the nozzle throat [52].

In support of the mass balance, an expression for the burning rate pressure relationship has been developed by Summerfield and co-workers [53] from a mathematical analysis which used the following simplifying approximations:

$$1/r = a/P + b/(P)^{1/3} \quad (7)$$

or, in another form:

$$P/r = a + bP^{2/3} \quad (8)$$

A “Granular Diffusion Flame Model” has also been postulated [54] for composite propellant burning based on a one-dimensional model, assuming direct pyrolysis of both fuel and oxidizer and with all reactions occurring in a thin diffusion flame zone in the gas phase. The vapour of fuel and oxidizer were postulated to be released in the form of pockets which proceeded to burn in the surrounding medium of the opposite reactant. The mass of each pocket is much smaller than that of an oxidizer crystal but related to it and independent of pressure. Burning occurs as a result of thermal conduction of energy back from the flame to the surface. However, this theory does not predict the absolute burning rates of solid propellants [55].

3.3 Ballistic Evaluation Motor (BEM) Tests

Ballistic Evaluation Motor (BEM) tests are carried out at different stages in the life cycle of a propellant. The results from the BEM tests are valuable in predicting the performance of full scale rocket motors. The burning rate of the propellant at different combustion chamber pressures and pressure indexes are evaluated by BEM tests.

Methods of Evaluation of Propellants by the BEM test

The performance of the propellant is evaluated by following methods:

1. Progressive Burning.
2. Neutral Burning.
3. Regressive Burning.

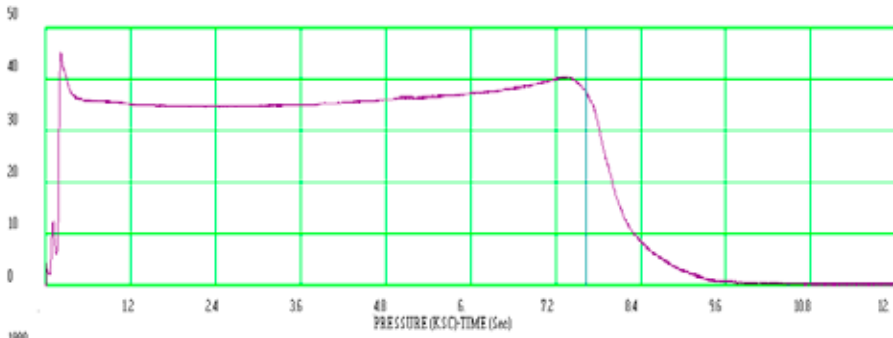

Figure 10. Pressure-time profile of a 40 kg motor (BEM) [53].

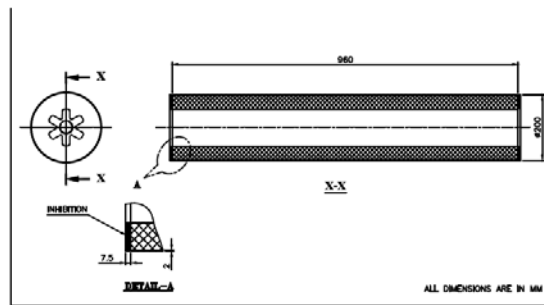

Figure 11. Drawing of a ballistic evaluation motor, BEM (40 kg) [53].

A pressure-time curve of a static firing test is presented in Figure 10 [56]. The BEM used a 6 petal star grain of outer diameter, web thickness and length 200, 40 and 960 mm, respectively. Both ends of the propellant grain were inhibited to allow radial burning only. A drawing of a 40 kg BEM is depicted in Figure 11 [56]. The burning rate is calculated by using following equation:

$$r_{P_{tbav}} = \text{Web thickness/Burn time} \tag{9}$$

where: $r_{P_{tbav}}$ is the burning rate at burn time average pressure; P_{tbav} is the burn time average pressure.

$$r_{P_{std,P}} = (P_{std}/P_{tbav})^n X r_{P_{tbav}} \tag{10}$$

where: $r_{P_{std,P}}$ is the burning rate at standard pressure; P_{std} is the standard pressure; n is the pressure index.

Although the BEM technique is very reliable and accurate, it requires a large quantity of propellant (40 kg) in comparison to the other techniques, hence it is only preferred for production lots of propellant.

4 Experimental Methods for the Determination of the Erosive Burning Rate of Solid Propellants

Various experimental methods have been employed for the determination of erosive burning, such as the X-ray flash method [57, 58], the pressure pickup method [59], the probe method [60], the interrupted burning method [58, 61-63], the indirect motor firing method [64], the servomechanism measurement technique [65], the high speed motion picture method [66], *etc.*

4.1 X-ray Flash Method

In this method, an X-ray beam is directed through the test motor onto an image intensifier tube that focuses the image onto a phosphor screen where it is photographed. The average burning rate is calculated from the increase in the hole diameter during the actual time interval. Marklund and Lake [57] and Kriedler [58] used this method to measure the erosive burning rate. Saderholm [67] also used the same method for the measurement of erosive burning of polybutadiene propellants.

4.2 Pressure Pickup Method

This method has been used by Marklund and Lake [57] to measure the erosive burning rate of composite solid propellants. In this method, a tablet of the propellant sample is centered over a small hole in the pressure pickup plug, as shown in Figure 12. A rapid increase in the pressure in the plug is observed as the tablet is consumed. The burning rate is calculated using the pressure-time profile.

4.3 Probe Method

This method is based on detecting the arrival time of the flame front at preselected points in the propellant grain. The burning rate is calculated from the difference in probe locations and the time difference between flashing indicator lamps. Dickinson *et al.* [59] used conductivity type probes for the measurement of erosive burning in a large polyurethane propellant grain.

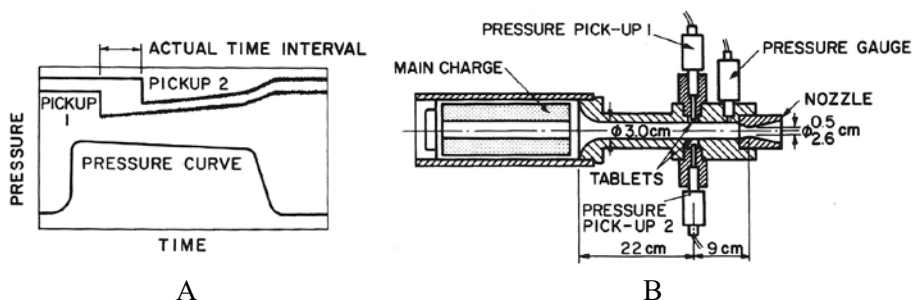

Figure 12. Pressure pickup method for the measurement of erosive burning; (A) Tablet method with pressure pickup gauges, and (B) Pressure-Time records [54].

4.4 Interrupted Burning Method

In this method, the burning is interrupted when the propellant charge is partially consumed. The grain dimensions and weight are measured before and after firing to give the average burning rate. The propellant grain is positioned in a steel chamber where a nozzle assembly is attached with the help of two explosive bolts, as shown in Figure 13. When the combustion pressure reaches a certain predetermined level the timer is initiated. The timer detonates the explosive bolts at a preset time after ignition and gives the partial burning time. After the complete explosion of the bolts, the nozzle assembly is detached from the motor and pushed along two steel cables. This technique has been used by several researchers [58, 60-63].

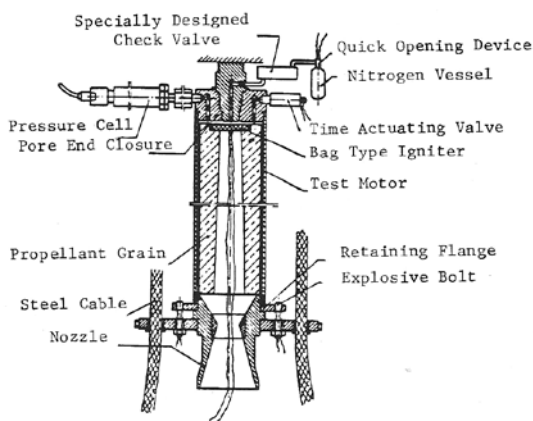

Figure 13. Interrupted Burning test system for the measurement of erosive burning [59].

4.5 Indirect Motor Firing Method

This method is based on an analysis of the pressure-time record of a test firing. Various methods have been developed involving the use of the pressure-time record [68-71].

4.6 Servomechanism Measurement Technique

This technique was introduced by Osborn and Burick [65] for erosive burning rate measurement. A schematic diagram of the experimental set up for the servomechanism technique is shown in Figure 14. This technique gives the instantaneous burning rate. Razdan and Kuo [72] also described a laser photodiode servomechanism technique for the measurement of erosive burning.

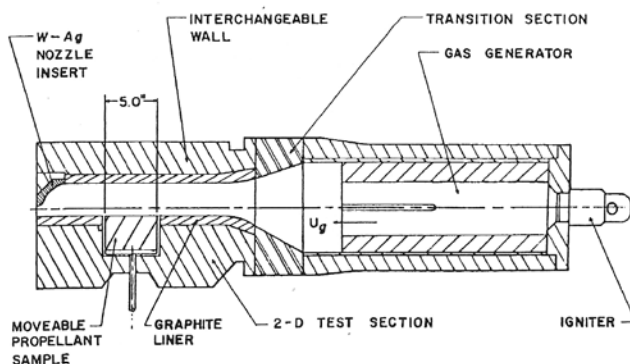

Figure 14. Servomechanism technique for the measurement of erosive burning [62].

4.7 High Speed Motion Picture Method

Razdan and Kuo [66] designed an experimental setup as shown in Figure 15 for the evaluation of erosive burning. In this method, the test section containing the propellant sample is equipped with a transparent window as shown. A high-speed motion picture of the propellant burning process is recorded and the burning rate is determined by measuring the web thickness burned during a given time interval. This method has been used by many researchers [58, 71, 73-75].

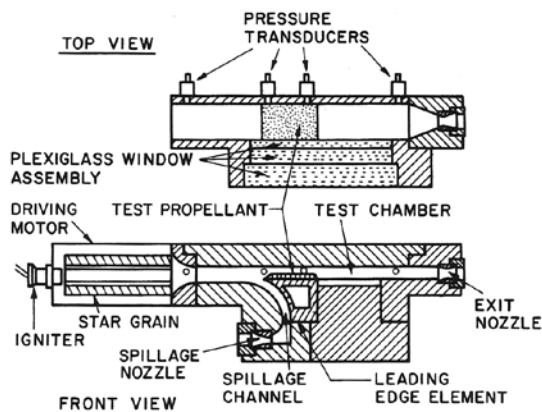

Figure 15. High speed motion picture method for the measurement of erosive burning [63].

5 Other Methods Used for the Determination of the Burning Rates of Solid Propellants

5.1 T-Burner Technique

The T-burner is primarily used to measure the combustion response of a propellant to pressure coupling [76-78], although it can also be used to measure the burning rate. This is basically a centrally-vented cylindrical chamber with two discs (25×10 mm) of solid propellant of equal thickness which are mounted on either end of the chamber as shown in Figure 12, and ignited simultaneously [79]. The geometry of the T-Burner is designed to study the effect of acoustic pressure oscillations on the solid rocket propellant. The T-Burner acoustic oscillations grow spontaneously after firing and the rate of change of the pressure amplitude oscillations is measured by a piezoelectric quartz pressure transducer. From these measurements the burning rate, admittance and response function of the propellant are calculated by the following equations, respectively:

$$r = \text{thickness of propellant disc/burn time} \quad (11)$$

$$A_b = Pu' / a_b P' \quad (12)$$

$$R_b = Pr' / rP' \quad (13)$$

where: r is the burning rate; A_b is the admittance; Pu' is the perturbation in the gas velocity; R_b is the pressure-coupled response function; r' is the perturbed burning rate; P' is the perturbed pressure; P is the mean chamber pressure.

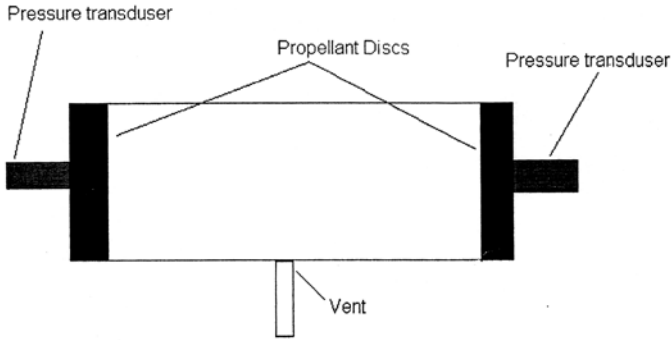

Figure 16. Schematic representation of the T-Burner technique [75].

5.2 Magnetic flow meter

This method is also used for the measurement of the burning rate, admittance and response function of the propellant. In this method, a combustion chamber is located within the field of a large permanent magnet, as depicted in Figure 13. The pressure within the burner is modulated through the nozzle. As the propellant burns, the electrical potential produced is detected by two electrodes within the burner. The signals from the flow meter electrodes and a pressure transducer are analyzed by a voltmeter. The system was designed by Wilson and Mici and was used to measure the pressure coupled response of solid propellants at higher frequencies [80, 81].

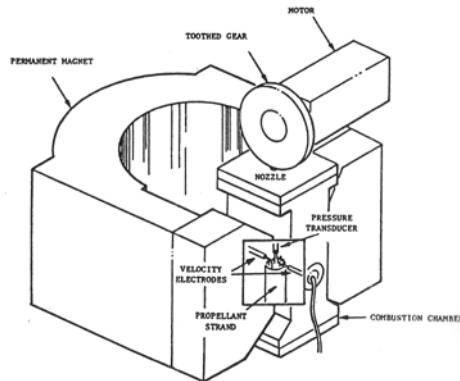

Figure 17. Magnetic flow meter burner for the measurement of burning rate [77].

6 Conclusions

A successful attempt has been made to review various methods for the determination of the burning rates of solid rocket propellants by highlighting the ease of application, and the merits and demerits of each technique. The effects of different parameters, such as pressure in the combustion chamber, the initial temperature of the propellant grain, the composition of the propellant, the particle size of the oxidizer and erosive burning have also been described. The review reveals that although the Crawford bomb is the oldest technique for the determination of burning rates, it is mostly only suitable for double base propellants with an accuracy of 97-98%. In the same way, other advanced techniques such as closed bomb, ultrasound measurement, microwave, X-ray and plasma capacitance need dedicated and experienced personnel, while the chimney type strand burner and laser techniques are very sophisticated but tedious in nature. Furthermore, various experimental methods such as X-ray flash method, pressure pickup method, probe method, interrupted burning method, indirect motor firing method, servomechanism measurement technique and high speed motion picture method for the determination of erosive burning are also described. The technique that is preferred over other techniques for the determination of the burning rate is acoustic emission, as it is very simple, fast, cost-effective and can be performed with an accuracy of 98%. However, for a more accurate burning rate, BEM is used. However BEM requires a large quantity of propellant. Hence, for day to day applications, the acoustic emission technique is being used efficiently by propellant scientists all over the globe.

Acknowledgements

The authors would like to thank Mr. Ramesh Kurva and Mr. Sunil Jain for their support with BEM and T-burner facilities, respectively.

7 References

- [1] Sutton G.P., *Rocket Propulsion Elements*, Wiley, New York, **1992**, Ch. 11, pp. 417-437, ISBN-0-471-32642-9.
- [2] Geckler R.D., *Selected Combustion Problems-AGARD*, Pergamon Press, New York, **1954**.
- [3] Gossant B., Solid Propellant Combustion and Internal Ballistics of Motors, in: *Solid Rocket Propulsion Technology* (Davenas A., Ed.), Pergamon Press, Oxford, **1993**, pp. 111-112, ISBN 0-08-040999-7.

- [4] Huggett C., Combustion of Solid Propellants, in: High Speed Aerodynamics and Jet Propulsion, in: *Combustion Processes*, (B. Lewis, R.N. Pease, H.S. Taylor, N.J. Princeton, Eds.) Vol. 2, Princeton University Press, **1956**, p. 565, ASIN: B000H4LKOE.
- [5] Kshirsagar D.R., Sudhir, Mehilal, Singh P.P., Bhattacharya B., Evaluation of Nano-Fe₃O₄ in Composite Propellant Formulations, *Int. J. Energ. Mater. Chem. Propul.*, **2013**, 12(6), 463-474.
- [6] Rumbel K.E., Advances in Chemistry: PVC Plastisol Propellants, Propellant Manufacture, Hazard and Testing, *J. Am. Chem. Soc.*, **1969**, 88, 46-56.
- [7] Klager K., Petersen R.A., Fine Ammonium Perchlorate Manufacture by Use of Vibro-energy Mill Wet Grinding Process, *Int. Jahrestag. – Fraunhofer-Inst. Treib-Explosivst.*, **1981**, p. 7.
- [8] Razdan M.K., Kuo K.K., Erosive Burning of Solid Propellant, in: *Fundamentals of Solid Propellant Combustion*, (Kuo K.K., Summerfield M., Eds.), Progress in Astronautics and Aeronautics, Princeton Combustion Research Laboratories, New Jersey, **1984**, Ch. 10, p. 520, ISBN-0-915928-84-1.
- [9] Glick R.L., Temperature Sensitivity and Erosive Burning, *J. Spacecrafts Rockets*, **1979**, 16(1), 58-59.
- [10] Crawford B.L., Huggett C., Daniels F., Wilfong R.E., Direct Determination of Burning Rates of Propellant Powders, *Anal. Chem.*, **1947**, 19(19), 630-633.
- [11] Grune D., Kegler W., Nicolas M., Benhaim P., Studies of the Combustion of Solid Propellants at High Pressures, *Proc. Int. Symp. Ballist.*, 3rd, A2, **1977**, p. 12.
- [12] Kleger K., Zimmerman G.A., Steady Burning Rate and Affecting Factors, in: *Non Steady Burning and Combustion Stability of Solid Propellants*, (DeLuca L., Price E.W., Summerfield M., Eds.), American Institute of Aeronautics and Astronautics, Washington, **1992**, p. 63, ISBN-978-15663-47-014-1.
- [13] Akira I., Kiroku Y., Kazuo K., Shoichiro A., Isao K., Burning Rate Measurement of Solid Propellants by Means of Phototransistors (in Japanese), *Kogyo Kagaku Zasshi*, **1962**, 65, 1218-1219.
- [14] Phung P.V., Hardt A.P., Burning Rates of Solid Propellants by a Variable Pressure Method, *Explosivstoffe*, **1968**, 12, 274-280.
- [15] Lui F., A New Method for Measurement of Burning Rate of Propellant and Explosives, in: Combustion and Detonation Phenomena, 19th Int. Annu. Conf. ICT, Karlsruhe, **1988**, 49/1-49/11.
- [16] Richard B.C., High Pressure Solid Propellant Combustion Studies Using a Closed Bomb, NASA Accession No. N65-34852, Report No. AD.471575, **1965**, p. 63.
- [17] Warren F.A., *Rocket Propellants: the Burning of Propellants*, Reinhold Publishing Corporation, New York, **1958**, p. 89, ASIN: B000OM3TDE.
- [18] Frederick R.A., Jr., Traineau J.C., Popo M., Review of Ultrasonic Technique for Steady State Burning Rate Measurements, 36th AIAA/ASME/SAE/ASEE Joint Propulsion Conference and Exhibit, AIAA Pap., Huntsville, Alabama, USA, **2000**, 2000-3801.
- [19] Song S.J., Kim H.J., Ko S.F., Oh H.T., Kim I.C., Yoo J.C., Jung J.Y., Measurement

- of Solid Propellant Burning Rates by Analysis of Ultrasonic Full Waveforms, *J. Mech. Sci. Technol.*, **2009**, 23(4), 1112-1117.
- [20] Desh D., Jeenu R., Sridharan P., Padmanabhan M.S., Application of Ultrasonic Technique for Measurement of Instantaneous Burn Rate of Solid Propellants, *Def. Sci. J.*, **1998**, 148(2), 197-204.
- [21] Cauty F., Non Intrusive Measurement Methods Applied to Energetic Material Regression Rate Determination, *Proc. 2nd Int. High Energy Materials Conference and Exhibit*, IIT Madras, Chennai, **1998**, 3-17.
- [22] Keiichi H., Katsuya H., Shigeru S.S., Toshio Y., Masataka, S., Modified Ultrasonic Method for the Study of Burning Rate Characteristics for Propellants, *31st Int. Annu. Conf. ICT*, **2000**, 32/1-32/12.
- [23] Jeffery J.M., Herman K., Evaluation of Ultrasound Technique for Solid-propellant Burning-rate Response Measurements, *J. Propul. Power*, **2002**, 18(3), 641-651.
- [24] Song S.J.J., Jeon H., Kim H.J., Kim I.C., Yoo J.C., Jung J.Y., Burning Rate Measurement of Solid Propellant Using Ultrasound – Approach and Initial Experiments, Review of Progress in Quantitative Nondestructive Evaluation 25B, *AIP Conference Proceeding*, Melville, New York, **2006**, 1229-1236.
- [25] Zarko V.E., Vdovin D.V., Perov V.V., Methodical Problems of Solid Propellant Burning Rate Measurement using Microwaves, *Combust. Explo. Shock Waves (Engl. Transl.)*, **2000**, 36(1), 62-71.
- [26] Strand L.D., Brown, R.S., Laboratory Test Methods for Combustion-stability Properties of Solid Propellant, in: *Nonsteady Burning and Combustion Stability of Solid Propellants*, (DeLuca L., Price E.W., Summerfield M., Eds.), American Institute of Aeronautics and Astronautics, Washington, **1992**, p. 699, ISBN-978-15663-47-014-1.
- [27] Johnson D.L., *Microwave Measurement of the Solid Propellant Burning Rates*, Giannini Controls Corp., TN, Duarte, CA, **1962**.
- [28] Wood H.L., O'Brien W.F., Dale C.B., Measurement of Solid Propellant Burning Rates Employing Microwave Techniques, *20th JANNAF Combustion Meeting*, **1983**.
- [29] Kilger J.J., *Measurement of Solid Propellant Burning Rates in a Slab Motor Environment Using a Microwave Technique*, M.S. Thesis, Virginia Polytechnic Institute and State University, Blackburg, VA, **1984**.
- [30] O'Brien W.F., Wood H.L., Kliger J.J., Dale C.B., Multiple Reflection Theory for Microwave Measurement of Solid Propellant Burning Rates, *21th JANNAF Combustion Meeting*, **1984**.
- [31] Boley J.B., *Microwave Data Reduction Technique for Calculation of Solid Propellant Burning Rates*, M.S. Thesis, Virginia Polytechnic Institute and State University, Blackburg, VA, **1984**.
- [32] Bozic V.S., Blagojevic D.D., Anicin B.A., Measurement System for Determining Solid Rocket Propellant Burning Rate using Transmission Microwave Interferometry, *J. Propul. Power*, **1997**, 13(4), 457-462.
- [33] Bozic V.S., Blagojevic D.D., Anicin B.A., Measurement System for Determining

- Solid Rocket Propellant Burning Rate Using Transmission Microwave Interferometry, *J. Propul. Power*, **1998**, 14(4), 421-428.
- [34] Foss D.T., Roby R.J., O'Brien W.F., Development of a Dual-frequency Microwave Burn-rate Measurement System for Solid Rocket Propellant, *J. Propul. Power*, **1993**, 9(4), 497-498.
- [35] *AEDC Test Highlights*, Published by Office of Public Affairs, Arnold Engineering Development Center, Fall, **1992**.
- [36] Masahiro K., Angelo V., Shin-Ichiro T., X-ray Diagnostics for Local Burning Rate Measurement of Solid Propellants, *Proc. Int. Symp. Spec. Top. Chem. Propul.*, Stockholm, **1997**, 918-926.
- [37] Osborn J.R., Bethel H.E., Technique for Measuring Burning Rates of Solid Propellants, *Rev. Sci. Instrum.*, **1964**, 35(9), 1130-1134.
- [38] Butt A., A Review of Real Time Radiography as a Solid Propellant Burn Rate Measurement Technique, *AIAA Region II Student Conference*, Memphis, TN, **2014**.
- [39] Yang L.C., Miner E.L., Romanos T.C., Application of Plasma Capacitance Gauge for Real Time Measurements of Solid Rocket Motor Internal Insulation Erosion, *AIAA Pap.*, 90-2327.
- [40] Strand L.D., *Erosive Augmentation of Solid Propellant Burning Rate: Motor Size Scaling Effect*, CPIA Publication 557, Vol. 3, **1990**, pp. 379-391.
- [41] Kubota N., Propellants and Explosives: Thermochemical Aspects of Combustion. Measurements of Burning Rate and Combustion Wave Structure, Wiley-VCH, **2002**, 235-236, ISBN: 9783527302109.
- [42] Reese D.A., Groven L.J., Son S.F., A New Nitrate Ester Composite Propellant, *Proc. 5th European Conference for Aeronautics and Space Sciences*, **2013**.
- [43] Osborn J.R., Murphy J.M., Kershner S.D., Photographic Measurement of Burning Rates in Solid-propellant Rocket Motors, *Rev. Sci. Instrum.*, **1963**, 34, 305-306.
- [44] Eisenreich N., Kugler H.P., Sinn F., An Optical System for Measuring the Burning Rate of Solid Propellant Strands, *Propellants Explos. Pyrotech.*, **1987**, 12(3), 78-80.
- [45] Wang J., Sang B., Laser Technique for Determining Solid Propellant Transient Burning Rates During Oscillatory Combustion, *Fuel*, **1998**, 77(15), 1845-1849.
- [46] Wang J., Gao Z., Sang B., A Laser Technology for Measurement of Solid Propellant Transient Burning Rates During Rapid Depressurization, *Fuel*, **2001**, 80(2), 263-271.
- [47] Caveny L.H., Pokroclos L.M., Lelshain G.R., *High Pressure Burning Rates of Multibase Propellants*, Department of Aerospace and Mechanical Sciences, Princeton University, New Jersey, Report AMS-1377, **1977**, p.75.
- [48] Muhammad R.H., Khawar H., Sajid R., Burning Rate Testing Techniques – A Comparative Study between Strand Burner and Ballistic Evaluation Motors, *Theory Pract. Energ. Mater., Proc. Int. Autumn Semin. Propellants, Explos. Pyrotech.*, **2007**, 373-375.
- [49] Fry R.S., *Evaluation of Methods for Solid Propellant Burning Rate Measurements*, NATO RTO, Technical Report No. RTO-TR-043, NATO RTO AVT Working Group 016, Johns Hopkins University/CPIA, **2002**.

- [50] Brooks W.T., A Method for More Reproducible Burning Rate Determination, *J. Spacecraft Rockets*, **1970**, 7(12), 1488-1489.
- [51] Whitney C.K., Owens T.F., Paskind J., Rubin M.B., *Scout Motor Performances and Prediction Study (PAPS)*, NASA-CR-336, NASA Langley Research Center, **1965**.
- [52] Brooks W.T., *Workshop Report: Burn Rate Determination Methodology*, CPIA Publication 347, Vol. 2, **1981**, pp. 183-191.
- [53] Summerfield M., Sutherland G.S., Webb M.J., Taback H.J., Hall K.P., *Burning of Ammonium Perchlorate Propellants*, American Rocket Society, New York, **1958**, pp. 737-758.
- [54] Summerfield M., Sutherland G.S., Webb M.J., Taback H.J., Hall K.P., *Solid Propellant Rocket Research*, Vol. 1, Academic Press, Inc., New York, **1960**.
- [55] Sarner S.F., *Propellant Chemistry: Solid Propellant Internal Ballistics*, Reinhold Publishing Corporation, **1966**.
- [56] Kumari A., Kurva R., Jain S., Jawalkar S.N., Mehilal, Singh P.P., Bhattacharya B., Evaluation of Nano-aluminum in Composite Propellant Formulation Using Bicurative System, *J. Propul. Power*, **2015**, 31(1), 393-399.
- [57] Marklund T., Lake A., Experimental Investigation of Propellant Erosion, *ARS Journal*, **1960**, 3, 173-178.
- [58] Kreidler J.W., Erosive Burning: New Experimental Techniques and Methods of Analysis, *AIAA Pap., Solid Propellant Rocket Conference*, Palo Alto, Calif., **1964**, 64-155.
- [59] Dickinson L.A., Jackson F., Odgers A.L., Erosive Burning of Polyurethane Propellant in Rocket Engine, *Eighth International Symposium on Combustion*, Williams and Williams, Baltimore, MD, **1960**, 754-759.
- [60] Green L. Jr., Erosive Burning of Some Composite Solid Propellants, *Jet Propul.*, **1954**, 24, 9-15.
- [61] Peretz A., Investigation of the Erosive Burning of Solid Propellant Grains with Variable Port Area by Means of Interrupted Burning Experiments, *Israel J. Technol.*, **1965**, 3, 94-101.
- [62] Peretz A., Experimental Investigation of the Erosive Burning of Solid Propellant Grains with Variable Port Area, *AIAA Journal*, **1968**, 6, 910-912.
- [63] Lawrence W.J., Deverall L.I., The Erosive Burning Behavior of Selected Composite Propellants, *Fourth ICRPG Combustion Conference*, Stanford, Calif., **1967**.
- [64] Williams F.A., Barriere M., Huang N.C., *Fundamental Aspects of Solid Propellant Rocket*, AGARD 116, **1969**, 395-456.
- [65] Osborn J.R., Burick R.J., A Technique for the Measurement of the Erosive Burning Rate of Solid Rocket Propellants, *Second International Symposium on Nucleonics in Aerospace*, Columbus, Ohio, **1967**.
- [66] Razdan M.K., Kuo K.K., Measurements and Model Validation for Composite Propellants Burning Under Cross Flow of Gases, *AIAA Journal*, **1980**, 18, 669-677.
- [67] Saderholm C.A., A Characterization of Erosive Burning for Composite H- Series Propellants, *AIAA Pap., Solid Propellant Rocket Conference*, Palo Alto, Calif., **1964**.

- [68] Viles J.M., *Measurement of Erosive Burning Rates*, Rohm & Haas Co., Huntsville, Alabama, Technical Report, **1969**, 5-213.
- [69] Vilyunov V.N., Dvryashin A.A., An Experimental Investigation of the Erosive Burning Effect, *Combust. Explo. Shock Waves (Engl. Transl.)*, **1971**, 7(1), 38-42.
- [70] Vilyunov V.N., Dvryashin A.A., Margolin A.D., Ordzhonikidzo S.K., Pokhil, P.F., Burning of Ballistite Type H in Sonic Flow, *Combust. Explo. Shock Waves (Engl. Transl.)*, **1972**, 8(4), 501-505.
- [71] Takishita Y., Sumi K., Kubota N., Erosive Burning Phenomena, *18th Space Science and Technology Symposium*, Tokyo, Japan, **1974**, pp. 197-200.
- [72] Rajdan M.K., Kuo K.K., *Turbulent Boundary-layer Analysis and Experimental Investigation of Erosive Burning Problem of Composite Solid Propellant*, Scientific Report to U.S. Air Force Office of Scientific Research, AFOSR-TR-79-1155, **1979**.
- [73] King M.K., A Model of Erosive Burning of Composite Propellants, *J. Spacecrafts Rockets*, **1978**, 15, 139-146.
- [74] King M.K., Model for Steady State Combustion of Unimodal Composite Solid Propellants, *AIAA Pap.*, *16th Aerospace Sciences Meeting*, Huntsville, Alabama, **1978**, 78-216.
- [75] King M.K., Erosive Burning of Composite Solid Propellants: Experimental and Modeling Studies, *J. Spacecrafts Rockets*, **1979**, 16, 154-162.
- [76] Muhlfeith C.M., Sayer L., Combustion Instability of Low Smoke Propellants in Ballistic Test Motors and in the T-burner, *AIAA Pap.*, Washington, DC, **1974**, 74-202.
- [77] Miller R.R., Donohue M.T., Yount R.A., Martin J.R., *Control of Solids Distributions in HTPB Propellants*, Hercules Inc. Allegany Ballistics Lab., AFRPL TR-78-14, **1978**.
- [78] Strand L.D., Cohen N.S., Effect of HMX on the Combustion Response Function, *J. Spacecrafts Rockets*, **1980**, 17(6), 566-568.
- [79] Price E.W., Sofferis J.W., Combustion Instability in Solid Propellant Rocket Motors, *Jet Propul.*, **1958**, 28, 190-192.
- [80] Wilson J.R., Micci M.M., *Direct Measurement of High Frequency Solid Propellant Response Functions*, Chemical Propulsion Information Agency Publication 383, Vol. 1, Silver Spring, MD, **1983**, pp. 193-201.
- [81] Wilson J.R., Micci M.M., Direct Measurement of High Frequency Solid Propellant Pressure Coupled Responses, *J. Propul. Power*, **1987**, 3(4), 296-302.