

aviation propulsion, CFD, 3D structure, aerodynamic drag

Paweł MAGRYTA*

AERODYNAMIC RESEARCH OF THE OVERPRESSURE DEVICE FOR INDIVIDUAL TRANSPORT

Abstract

Paper proposes a solution of overpressure device for individual transport, the purpose of which is to accumulate the overpressure in a certain geometric area, through the use of specially designed three-dimensional structures. In order to verify the underlying assumptions of the idea, it was decided to perform a simulation study of air flow stream within the proposed unit. These studies were done in Star CD – Pro Star 3.2 software. Further studies were carried out on the actual real model. The verification was performed to compare and identify the main parameters of air flow through the three-dimensional structure.

1. INTRODUCTION

Nowadays, many urban agglomerations are trying to fight the problem of limited possibilities of improving the population transport. Commonly known transportation methods are based on ground movement, such as automobiles or rail. However, the close location of buildings in the cities centers prevents the further growth of this type of network connection (Gössling, 2016). There is also the possibility of transferring the transport into the underground, but the underground urban infrastructure of cities also has its limitations. More often, the new idea is an attempt to transfer the individual urban transport in the realm of air (Ambarwatia, Verhaeghe, Arem & Pel, 2017). This is facilitated by the development of the individual air transport devices, as well as the possibility

* Department of Thermodynamics, Fluid Mechanics and Aviation Propulsion Systems, Faculty of Mechanical Engineering, Lublin University of Technology, Nadbystrzycka Street 36, 20-618 Lublin, Poland, +48 815384764, e-mail: p.magryta@pollub.pl

to use ever newer technologies and materials, particularly in the field of electrical energy storage. The use of internal combustion engines to drive the individual means of transport seems to be impossible because of the noise and pollution that accompany their work. However, the use of the flying vehicle equipped with a conventional propellers drive also has several disadvantages. Standard propellers drives tend to be too loud. Therefore, there is need to design a new type of propulsion system, based on the principle of jet systems or airbag flying ship (Decker, Fleischer, Meyer-Soylu & Jens, 2013).

The main idea for the research contained in this work was the improvement of the air propulsion system, precisely, to create a new compressed air system which would replace engines used in flying vehicles. In this order, research simulations of air flow in a simulation model, in the STAR CD – Pro Star 3.2 software has been carried out. Additionally a geometric model in a Catia V5 virtual environment has been made (Welyczko, 2005). A final stage of work was the implementation of real model and the verification of the simulation results (Magryta, 2009).

2. SIMULATION

2.1. Simulation introduction

The main aspect of the design and purpose of the presented device was to obtain very high pressures and mass flows values of air stream. The initial objectives of the project focused on the idea of creating a model in which it would be possible to perform simulation studies, and subsequent execution on real model and check the pressures and flows values in real conditions.

The simulations were mainly based on the phenomenon of air flow contact to the one of the model walls, allowing for the further stabilization of the flow conditions, what gives a high values of pressure and mass flows, which was a primary design goal (Nedeff, Bejenariu, Lazar & Agop, 2013; Smirnova and Zvyaguin, 2011). Such a solution seemed to be very accurate idea, which created the possibility of obtaining high operating parameters, at the expense of very low power consumption (Magryta, 2009).

2.2. Boundary conditions

Simulations were made in the STAR CD – Pro Star 3.2 software, which allows for three-dimensional simulation of fluid flow (CFD). By using this application, it was possible to registry the changes in pressure and velocity versus simulation time, and the mass flows in some selected points of the simulation model (*Report I/02/2006*, 2006).

For the calculation carried out in the STAR – CD, it is necessary to create a suitable model with the appropriate computing grid. The adopted computing grid has a number of computing cells approx. 3500. It should be noted, that at the nozzle inlet, the grid was heavily concentrated, to enable accurate recording of pressure, velocity and mass flows values. View of computational grid is shown in figure 1. The blue lines (walls) are marked additionally, they limited the flow of air outside of the simulation model. In fact, in the place of these lines, in the STAR – CD, a boundary conditions restricting the air flows were added. While the orange arrow indicates the direction of the compressed air inlet to the simulation model (Magryta, 2009).

The main objective adopted in the design of the device, was to restrict the air flow through the sides and top of the model, what caused the accumulation of overpressure in the upper zone and the separation of its lower pressure zone by incoming air stream. It would cause overpressure, which reacts to the upper wall, what would be used as a thrust in the propulsion system (Hu, Lin, Fu & Wang, 2017; Juraeva, Ryu, Jeongc & Song, 2016; Moureh & Yataghene, 2016).

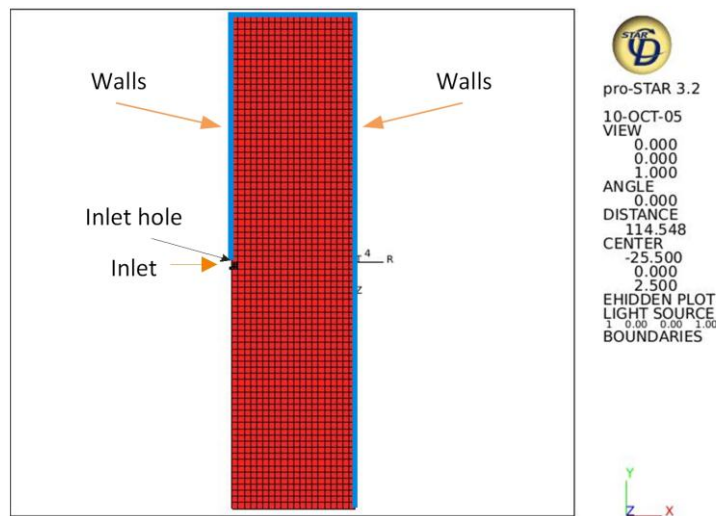

Fig. 1. Computing grid

2.3. Simulation results

The simulation was performed under the steady state conditions. The pressure in the inlet nozzle was linearly increased from zero to a predetermined value (0.25 and 0.5 bar). In both cases the vector map of the pressure and velocity were recorded, at the time from the start of the simulation to 0.08 sec. This time is due to the fact that after 0.08 seconds, the flow stabilizes and further simulations would be useless. As mentioned earlier, tests were conducted

for two different values of inlet pressure, however, because of the results size, it was decided to present the distribution of vector map of pressure and velocity flows only at the conditions of 0.5 bar pressure, as is shown in figures 2–9. (Magryta, 2009).

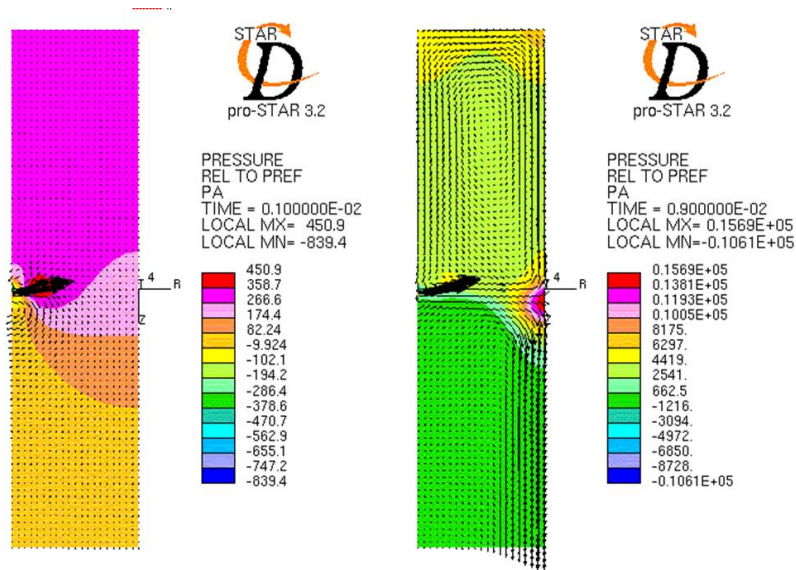

Fig. 2. Vector map of pressure, pressure 0.5 bar, time 0.001–0.009 sec.

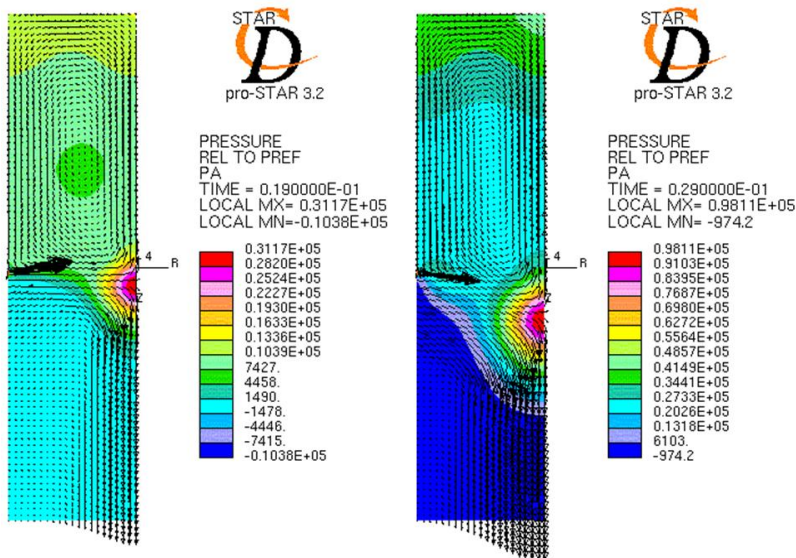

Fig. 3. Vector map of pressure, pressure 0.5 bar, time 0.019–0.029 sec.

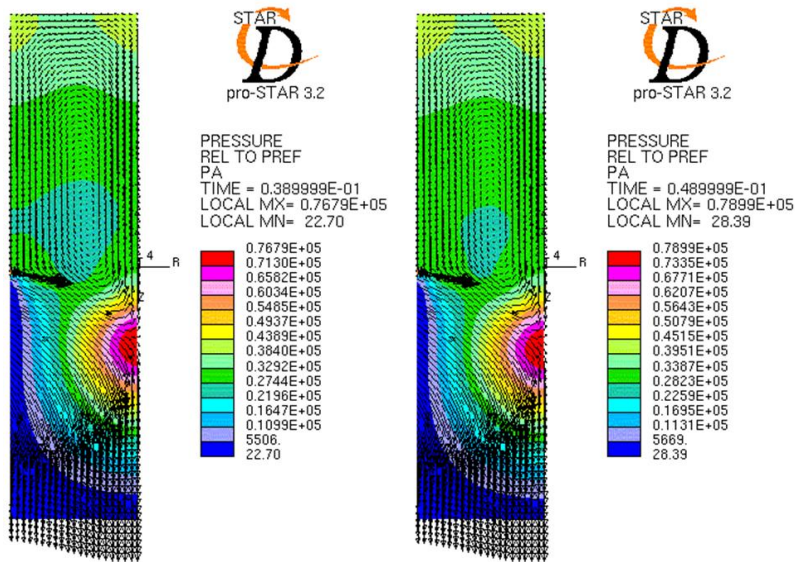

Fig. 4. Vector map of pressure, pressure 0.5 bar, time 0.031–0.049 sec.

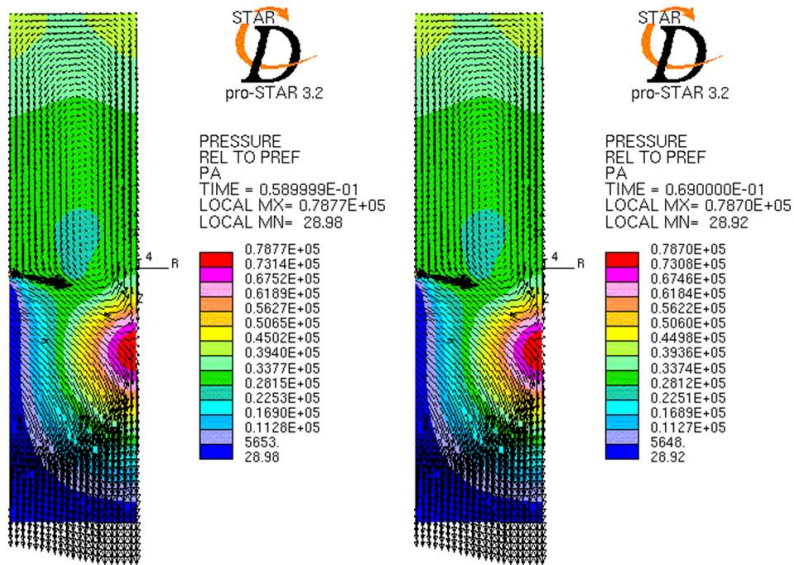

Fig. 5. Vector map of pressure, pressure 0.5 bar, time 0.059-0.069 sec.

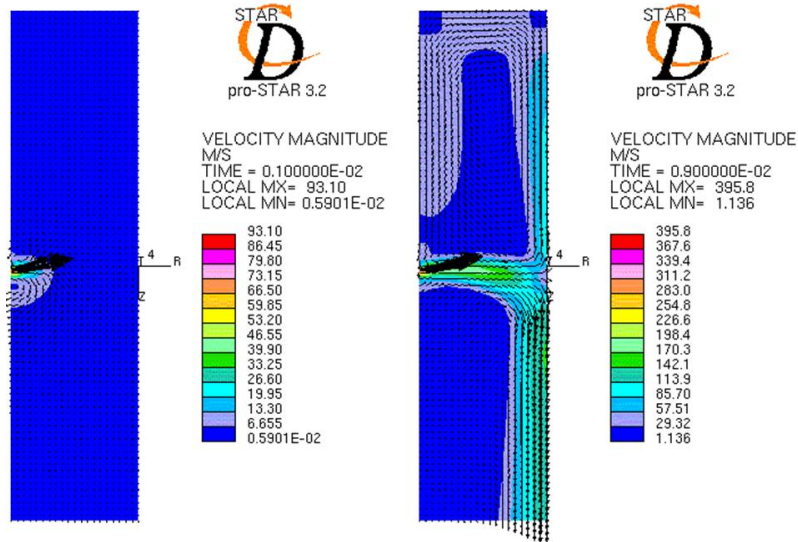

Fig. 6. Vector map of velocity flow, pressure 0.5 bar, time 0.001–0.009 sec.

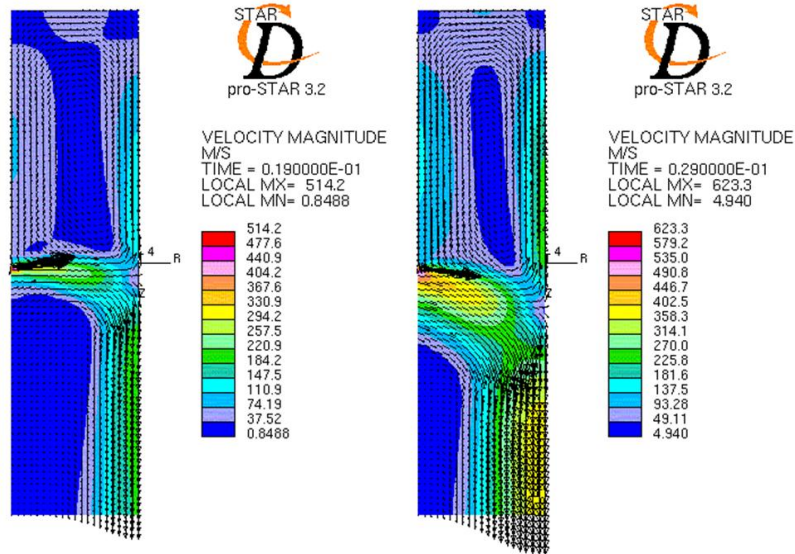

Fig. 7. Vector map of velocity flow, pressure 0.5 bar, time 0.019–0.029 sec.

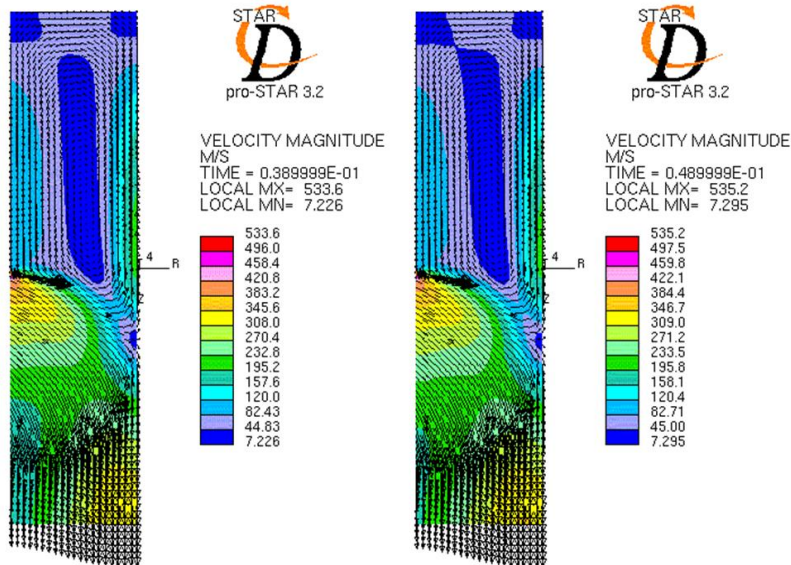

Fig. 8. Vector map of velocity flow, pressure 0.5 bar, time 0.031–0.049 sec.

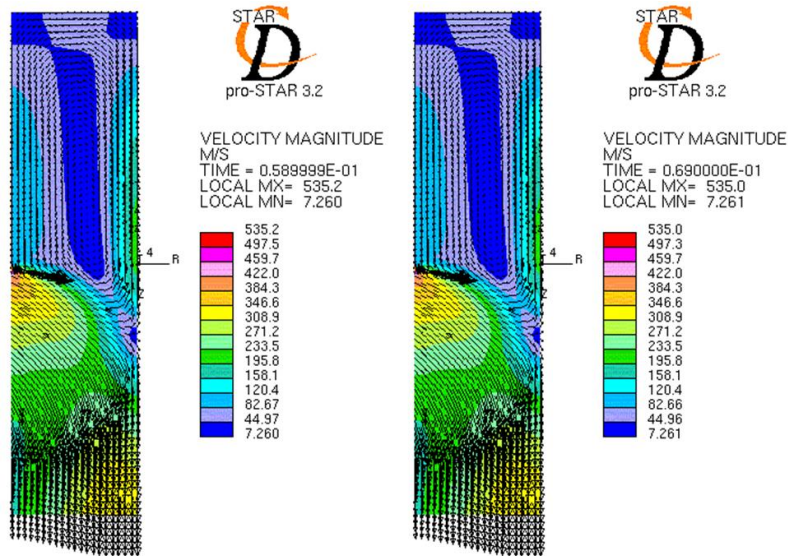

Fig. 9. Vector map of velocity flow, pressure 0.5 bar, time 0.059–0.069 sec.

During the simulation, the pressure, velocity and mass flows in the respective measuring points of the simulation model were recorded.

The pressure at the inlet nozzle and at the measuring point on the top of the device were recorded (Magryta, 2009). Figure 10 shows the characteristic of the pressure at the inlet nozzle and at the top side of the model.

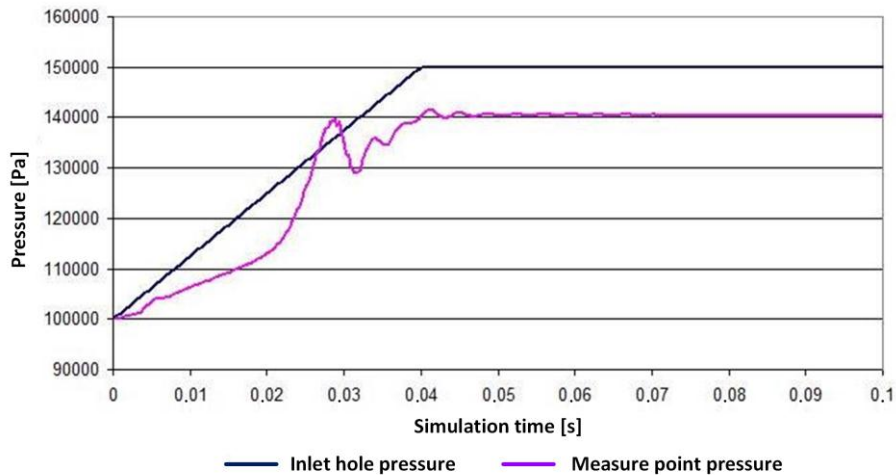

Fig. 10. Characteristic of the pressure at the measuring points during the simulation, in the case of supply of 0.5 bar pressure

All presented results of simulation conducted in the STAR – CD Pro-star 3.2 show clearly, that it is possible to obtain high values of pressure at the top part of the device. The whole concept of creating this kind of the model proved to be correct. After stabilization of conditions, the air flow adopted a laminar flow stream and the phenomenon of contacting airflow to one of the walls occurs. Such a shape of the stream and a large flow rate are blocking the possibility of air leakage beyond the closed top part of the model. All these phenomena mean that at the upper wall of the model a large pressure value is distributed uniformly over the length of the top wall. As can be seen from the distribution of the vector field of the pressure, it is possible to obtain a pressure of approx. 40,000 Pa, with the inlet pressure of 0.5 bar. The top wall of device has internal dimensions of 50 x 10 mm, so its surface is 500 mm². It can be said that such a small airbag is able to lift the approx. 2 kg of mass. Since the results of simulation confirm previously established hypotheses concerning the behavior of the air stream, the author began to create a real model, as shown in the following chapters of the work (Magryta, 2009).

3. EXPERIMENTAL RESEARCH

3.1. CAD model

In order to optimize the real model construction, it was decided to use a Catia v5. The main assumptions of the real model are:

- ability to test multiple geometrical settings,
- simplicity of the design,
- easiness of the real model assembly,
- possibility of setting multiple dimensions of the height of the inlet nozzle,
- short time of real model production,
- complete seal of real model,
- ability to measure pressure in many points,
- ability to measure the weight of the entire device during testing (Camba, Contero & Company, 2016; Zhu, Li & Martin, 2016).

View of the final geometric model in the Catia v5 software is shown in figure 11.

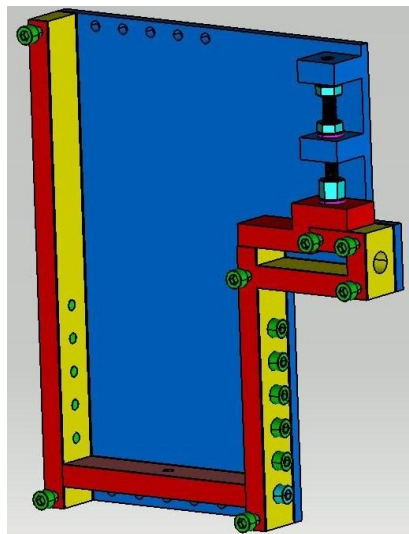

Fig. 11. View of the model without the front cover

3.2. Real Model

Most of the requirements and assumptions about the real model has been already fulfilled during the virtual design. According to calculations made in the Catia v5, the total mass of the model (assuming it will be made of steel) would be 6 kg. In order to reduce this value, front and back cover were made of aluminum sheet

2017 PA6, with a thickness of 5 mm. This value of the thickness has allowed to avoid the deformation of the whole covers, especially during the assembly of the model (Przybylski & Deja, 2007). The total mass of the real model was reduced to a value of 2.8 kg (Magryta, 2009).

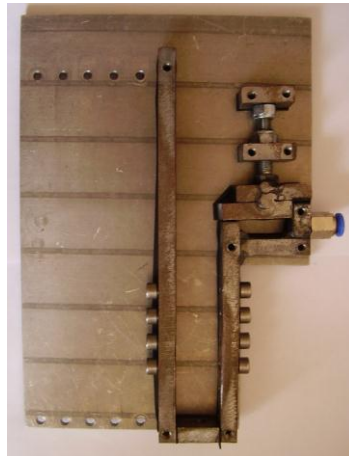

Fig. 12. Finished model in one of the actual geometric settings, excluding the front cover

3.3. Research test bench

Schematic diagram of the test bench is shown in figure 13.

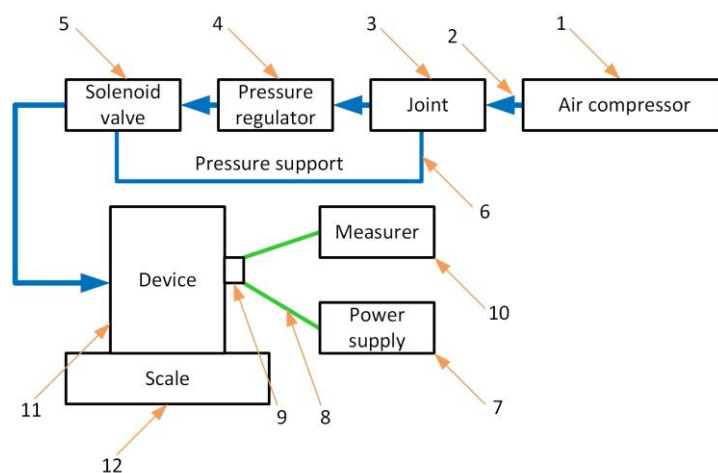

Fig. 13. Schematic diagram of test bench: 1 – air compressor, 2 – pressure line, 3 – joint, 4 – pressure regulator, 5 – solenoid valve, 6 – pressure support, 7 – power supply, 8 – powerline, 9 – pressure sensor, 10 – measurer, 11 – device, 12 – scale

Research carried out on the real model were based on certain assumptions resulting from the construction of the test bench, as well as the limitations of the hardware devices used during the tests. As is apparent from the simulation model, large pressure values at the measurement points, should be obtained even at the inlet pressure of 0.25 and 0.5 bar. In fact, after completely sealing of real model and the initiation of compressed air supply with such a values of pressure, it was impossible to obtain comparable results to the simulation model. However, if pressure at the inlet was higher, the values of obtain overpressure was bigger. Therefore the same pressure at the inlet nozzle of 2.2 bar was established, for all studies. Measurements were made at five different values of the height of the inlet nozzle (0.3, 0.6, 0.9, 1.2, 1.95 mm) and the position of pressure measuring point correspond to the position selected during simulation tests (Magryta, 2009).

3.4. Experimental research results

The only value that we can compare between the simulation study and real research is the actual pressure value at the measurement point on the upper side of the model. Compared to the simulation test, a weight values were read out from the scale, that has been added to the real model tests. In order to fully reflect the capabilities of the real model, a total of 180 measurements at five different positions of the inlet nozzle were made.

For comparison, the relationship between registered overpressure at the measuring point and the width and height of the chamber in which the pressure was accumulated, at two heights of the nozzle 0.3 mm (Figure 14) and 0.6 mm has been presented (Figure 15).

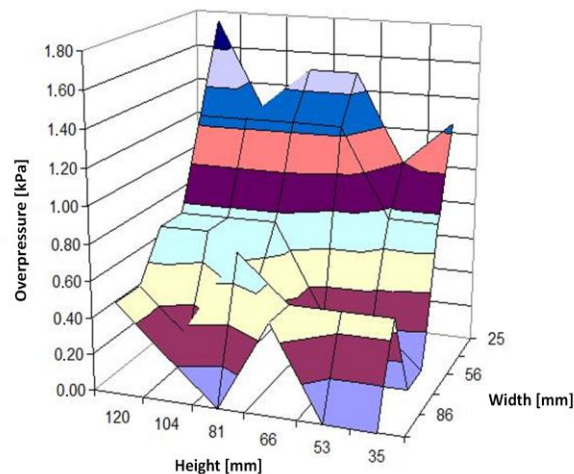

Fig. 14. Three-dimensional graph showing the variation of the level of overpressure at different geometric setup for the inlet nozzle 0.3 mm (own study)

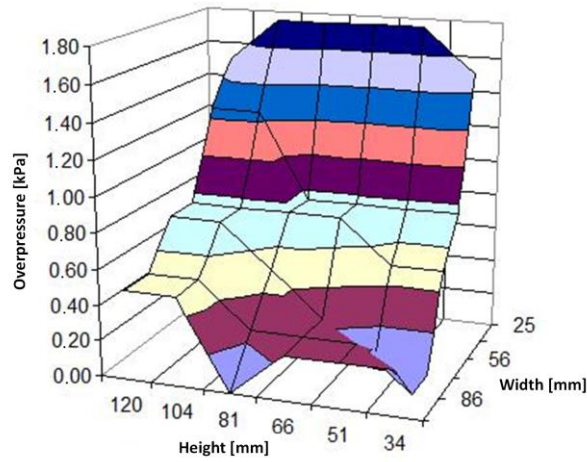

Fig. 15. Three-dimensional graph showing the variation of the level of overpressure at different geometric setup for the inlet nozzle 0.6 mm

A next measured value was so-called lift force, this value was recorded on a laboratory scale placed under the real model. The results of these measurements, analogical to results of pressure measurements, are shown in figures 16 (for the inlet nozzle 0.3 mm) and 17 (for the inlet nozzle 0.6 mm). Values read from the scale, are appropriately reduced by the mass of the real model, what gives the value of the actual lift force (Magryta, 2009).

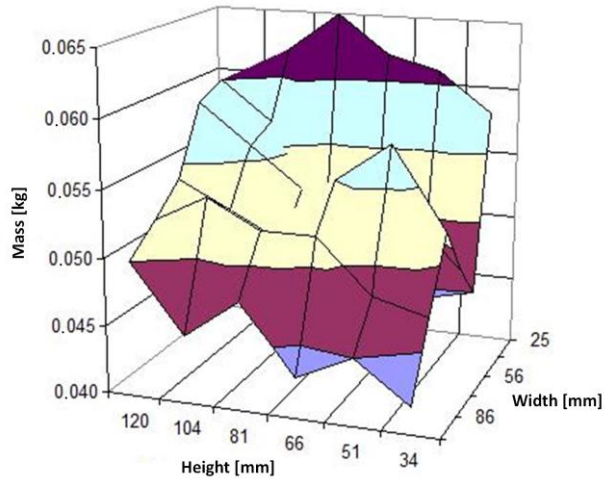

Fig. 16. Three-dimensional graph showing the variation of the level of lift force at different geometric setup for the inlet nozzle 0.3 mm

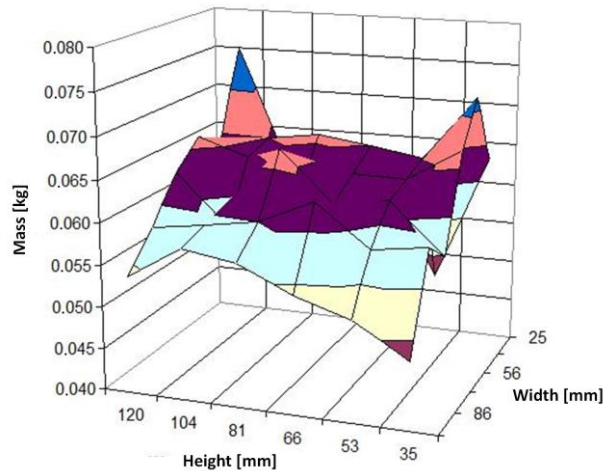

Fig. 17. Three-dimensional graph showing the variation of the level of lift force at different geometric setup for the inlet nozzle 0.6 mm

4. CONCLUSIONS

As follows from the conducted studies, it was failed to reproduce the full flow conditions conducted in simulation tests on a real object. Although the STAR – CD software takes into account all kinds of phenomena of local flow disturbances, changes in temperature, mixing, etc., all kinds of dimensions and boundary conditions given in this application are treated by the computer system in an ideal manner (Nazarewicz, Szlachetka & Wendeker, 2006). For example, setting of the wall, assumption that all connections are 100% tightness and all applied dimensions of the model are perfect and not subjected to any deviation. What is true, that in the real model it was able to fully seal the device, but the behavior of ideal dimensions of all geometric elements, such as walls, nozzle or covers: the front and rear, was very difficult. The maximum deviation resulting from the imperfections of the implementation of the real model could be 1 mm, but such a value in the point of inlet nozzle could cause some distortion of the air flow. According to the author, this was the main cause of such low pressures values at the measurement point.

In summary, the work provide accurate simulations of flow of compressed air through a simulation model in the STAR – CD software, creation of a structural model in the Catia v5 software, creation of a real model and tests on real model. And these are the main conclusions and suggestions for further research on this model:

- simulations carried out in the STAR – CD Pro Star 3.2 shows a very high potential in model in terms of obtaining high pressures and mass flows,

- Catia v5 software makes very easy to optimize the design of real model what is stated in Skarka & Mazurek (2005),
- despite the execution of possible high accuracy of real model, it was failed to reproduce the perfect geometry settings of walls and inlet nozzle,
- it was possible to fully seal the real model, by using the rubber seals of a thickness of 1 mm and 2 mm,
- results obtained from the real test differs from the values obtained in the simulation tests, what is a result of inaccuracy of real model, which obviously affects the course of the air flows,
- for further implementation of the model, it is proposed to make dozens of sets of geometry settings of device, and several inlet nozzles, with the use of the CNC processing machine, which would increase the accuracy of, real model (Magryta, 2009).

The maximum pressure values obtained for certain conditions was 2 kPa. This value is too low to exploit the apparatus as flying vehicle. However, both the model simulation and actual real tests, show a linear relationship with the value received between the overpressure and boundary conditions which have been presented in the work.

This work was funded by the Polish Ministry of Science and Higher Education.

REFERENCES

- Ambarwati, L., Verhaeghe, R., Arem, B., & Pei, A. J. (2017). Assessment of transport performance index for urban transport development strategies — Incorporating residents' preferences. *Environmental Impact Assessment Review*, 63, 107-115. doi:10.1016/j.eiar.2016.10.004
- Camba, J. D., Contero, M., & Company, P. (2016). Parametric CAD modeling: An analysis of strategies for design reusability. *Computer-Aided Design*, 74, 18–31. doi:10.1016/j.cad.2016.01.003
- Decker, M., Fleischer, T., Meyer-Soylu, S., & Jens, S. (2013). *Personal air vehicles as a new option for commuting in Europe: vision or illusion?* European Transport Conference 2013.
- Gössling, S. (2016). Urban transport justice. *Journal of Transport Geography*, 54, 1–9. doi:10.1016/j.jtrangeo.2016.05.002
- Hu, S.-C., Lin, T., Fu, B.-R., & Wang, T.-Y. (2017). Air curtain application in a purged unified pod. *Applied Thermal Engineering*, 111, 1179–1183. doi:10.1016/j.applthermaleng.2016.10.022
- Juraeva, M., Ryu, K. J., Jeongc, S.-H., & Song, D. J. (2016). Influences of the train-wind and air-curtain to reduce the particle concentration inside a subway tunnel. *Tunnelling and Underground Space Technology*, 52, 23-29. doi:10.1016/j.tust.2015.11.008
- Lublin University of Technology. (2006). *Report I/02/2006. Badania symulacyjne doświadczalnego układu wtryskowego silnika lotniczego K9-E*. Project 03605/CT12-6/2005.
- Magryta, P. (2009). *Simulation Research of the Aerodynamic contumacy of three-dimensional structures*. *MSC Thesis*, 3–4. Lublin University of Technology.
- Moureh, J., & Yataghene, M. (2016). Numerical and experimental study of airflow patterns and global exchanges through an air curtain subjected to external lateral flow. *Experimental Thermal and Fluid Science*, 74, 308–323. doi:10.1016/j.expthermflusci.2015.11.028

- Nazarewicz, A., Szlachetka, M., & Wendeker, M. (2006). Wykorzystanie programu Star – CD do modelowania zjawisk w silnikach spalinowych. In *Informatyka w technice. Tom I*. Lubelskie Towarzystwo Naukowe.
- Nedeff, V., Bejenariu, C., Lazar, G., & Agop, M. (2013). Generalized lift force for complex fluid. *Powder Technology*, 235, 685–695. doi: 10.1016/j.powtec.2012.11.027
- Przybylski, W., & Deja, M. (2007). *Komputerowo wspomagane wytwarzanie maszyn*. Warszawa: Wydawnictwo WNT.
- Smirnova, M. N., & Zvyaguin, A. V. (2011). Theoretical solution for the lift force of “ecranoplan” moving near rigid surface. *Acta Astronautica*, 68(11–12), 1676–1680. doi:10.1016/j.actaastro.2010.12.006
- Skarka, W., & Mazurek, A. (2005). *Catia – podstawy modelowania i zapisu konstrukcji*. Wydawnictwo Helion.
- Węlyczko, A. (2005). *Catia v5 – Przykłady efektywnego zastosowania systemu w projektowaniu mechanicznym*. Wydawnictwo Helion.
- Zhu, L., Li, M., & Martin, R. R. (2016). Direct simulation for CAD models undergoing parametric modifications. *Computer-Aided Design*, 78, 3–13. doi:10.1016/j.cad.2016.05.006