



## Laboratory Investigations on Perforation of 30PM Steel Plates

Jacek JANISZEWSKI, Michał GRAŻKA, Djalel Eddine TRIA,  
Zbigniew SURMA, Bartosz FIKUS

*Faculty of Mechatronics and Aerospace, Military University of Technology,  
2 Sylwestra Kaliskiego St., 00-908 Warsaw, Poland*

*\*corresponding author, e-mail: jacek.janiszewski@wat.edu.pl*

*Manuscript received July 05, 2014. Final manuscript received October 22, 2015*

DOI 10.5604/20815891.1203115

**Abstract.** In this study, high strength steel plates made of 30PM steel were subjected to 7.62 Armour Piercing projectiles at the ordnance velocity. Several experiments differing considerably in conditions of interaction between projectiles and plates were performed. Selected parameters were measured before, during, and after ballistic tests, and both projectile and plate were subjected to detailed examination. It is foreseen to use the obtained results in two ways. Protection performance of steel plates will be determined and experimental data will be used as a reference for analyzing various models and numerical techniques, accessible in commercially available hydrocodes. The authors present the methodology, the experimental set-up configuration, and the results of laboratory experiments.

**Keywords:** mechanics, hard armor steel, perforation, laboratory experiments

## 1. INTRODUCTION

The need for protection against small arms and light weapons is necessary in both military and civil applications. In the design of protective structures, armor steels are still the dominating materials although more advanced lightweight composite based armours are available [1, 2]. Their high hardness and strength combined with their relatively low cost made them dominating material for protection against small arms threats.

The paper presents laboratory investigations on perforation and penetration of high strength steel plates made of 30PM steel, subjected to Armour Piercing projectile  $7.62 \times 51$  mm AP. Several ballistic tests differing considerably in conditions of interaction between the projectile and the armor plates have been performed in order to determine the protection performance of the used steel against AP projectile at the ordnance velocity.

The high hardness steel 30PM is pretended to provide a good ballistic performance. However, it is important to determine the effect of target thickness and obliquity on the penetration process and failure mode, including projectile path and residual velocity, plug velocity, crater and holes dimensions, and plate deformation.

It is true that steel plates provide good protection when the thickness is big. If it is used to protect a stationary construction, then the mass is with less interest. However, structure mass has huge influence on vehicles. To protect people inside military vehicles, the steel armor has not to be very thick. This kind of solution generates the problem with mobility and it makes the structure very heavy and less practical. Therefore, it is very important to have material which has good protection performance with small thickness in order to decrease the total structure mass.

In this study, laboratory experiments were made inside a ballistic tunnel. The ballistic tunnel is located at the Institute of Armament Technology of the Military University of Technology in Warsaw. The investigations were conducted by a team specialized in shooting tests. Steel plates have various thicknesses 3, 6 and 8 mm subjected to normal and oblique impact.

An experimental set up was used under well controlled conditions. Optical device was used to measure the initial bullet velocity, while a high-speed camera was used to record the perforation process. The recorded images have been analyzed with special computer software (TemaMotion) in order to determine the residual speed of the bullet and plug velocity.

## 2. LABORATORY SET-UP

Figure 1 presents the ammunition used for tests. The antitank ammunition consists of a hardened steel core made of N12E steel, a brass jacket, and lead sabot. The schematic drawing geometry of the bullet is shown in Fig. 2.

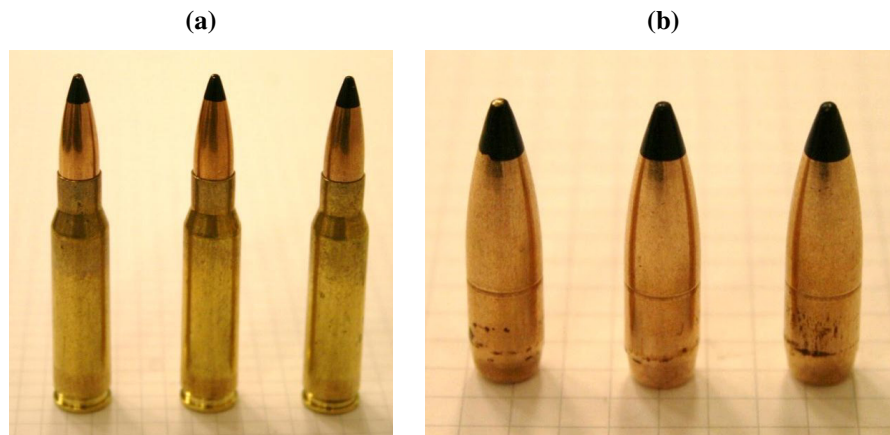

Fig. 1. Ammunition (a) and the antitank (AP) projectiles (b)

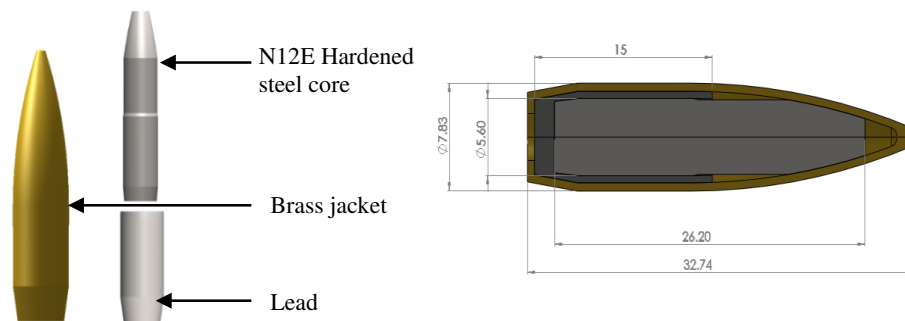

Fig. 2. Schematic drawing geometry of 7.62 mm AP bullet

The target plates with  $250 \times 250 \text{ mm}^2$  and different thicknesses (3 mm, 6 mm, 8 mm) were mounted in a stiff frame and adjusted to the desired impact angle (see Fig. 3). Here, maximum 4 shots were performed in each target before it was replaced. A laboratory rifle was used to fire  $7.62 \times 51 \text{ mm}$  AP ammunitions at the velocity of  $835 \pm 10 \text{ m/s}$  (Fig. 4). Note that seven shots were carried out for each plate configuration in order to provide an assessment of random scatter of the obtained experimental results.

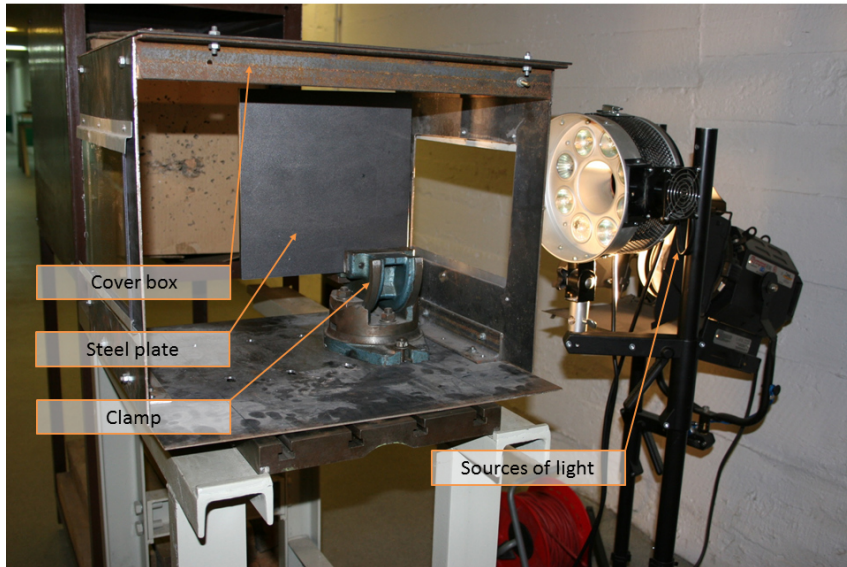

Fig. 3. Target plate mounting system

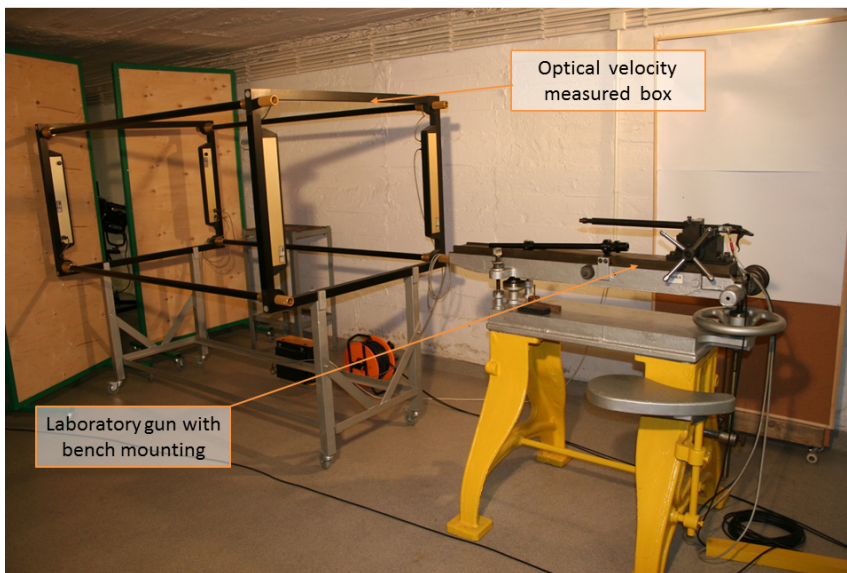

Fig. 4. Laboratory gun and optical velocity measurement system

During the tests, an optical velocity measuring system was available to measure the projectile initial velocity. When the projectile passes between the sources and detectors in the barrier, light is interrupted and signals are given to a digital oscilloscope and a nanosecond counter.

In addition, a Phantom v12.1 high speed camera was used for tests to record the projectile path before and after perforation, and to photograph the penetration process (see Fig. 5). The digital images have been analyzed with special computer software (TemaMotion) in order to determine the residual speed of the bullet and plugs velocity before they were captured in a rag box. Initial geometrical imperfections, thickness, and oblique of the target were measured prior each test. Final plate deformations, plug shape, plug mass and projectile residual mass were measured, too.

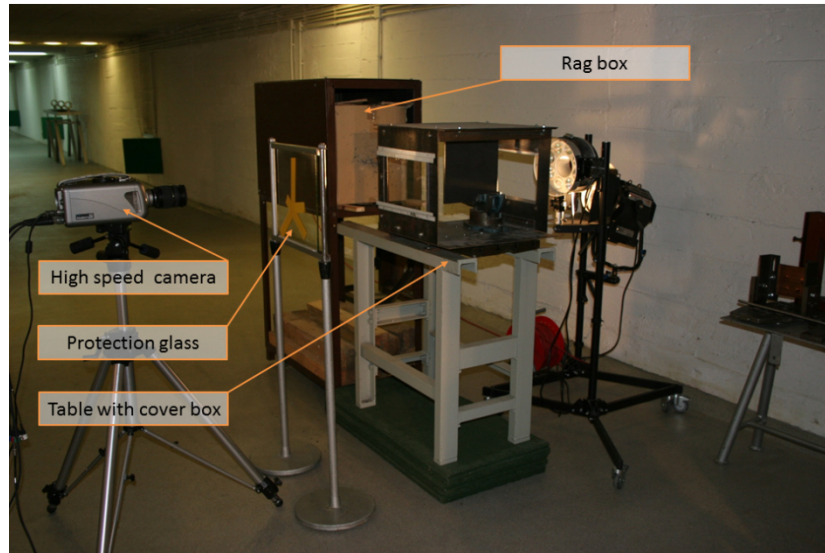

Fig. 5. Recording system used during shot tests

Several parameters were measured before, during and after ballistic tests, where both projectile and plate were subjected to detailed examination. Following, a list of parameters with their significance is presented:

$V_{iop}$	Initial projectile velocity measured by optical frame
$V_r$	Residual projectile velocity
$m_p$	Projectile mass
$\varphi_D$	Angle between initial and final trajectory of the projectile (Deflection angle)
$\varphi_R$	Projectile Ricochet angle
$\Theta$	Projectile impact angle
$H_t$	Initial plate thickness
$w_{max}$	Maximum target deformation
$H_B$	Bulge height

$X_p$	Penetration depth
$V_{pl}$	Plug velocity
$m_{pl}$	Plug mass
$\varnothing_{in}$	Inlet diameter of the plate hole
$\varnothing_{out}$	Outlet diameter of the plate hole
$D_c$	Crater length
$D_b$	Crater width
$D_r$	Plastic zone length on the rear surface

The shot test program is presented in Table 1. Note that a maximum of four (4) shots have been done for each target plate after the plate was replaced and new one used. The variation in the test condition includes the variation of the plate thickness and the plate obliquity. The determination of the plate thickness is based on the ratio between the plate thickness and projectile diameter in the aim of obtaining different perforation mechanisms and failure modes.

Table 1. Experimental shot test program

Test Condition	Plate type	Average Plate Thickness (mm)	Impact Angle ( $\theta$ )	Number of Shots
i	Thin	3.4	0°	7
ii	Intermediate	6.4	0°	7
iii	Thick	8.4	0°	7
iv	Plate of item „i”	3.4	50°	7
v	Plate of item „i”	3.4	60°	7

The mechanical properties of the 30PM armor plates of different thicknesses are presented in Fig.6 and compared with Armox 500T and 2P armor steels. The parameters of the 30PM steel plates are given by the Polish Company „HSW” and they present minimum values, however the parameters for Armox 500T and 2P steel are taken from the literature [11]. It is clearly seen that the 30PM steel used in this study provides high mechanical properties in comparison to Armox 500T and 2P armors. The variation of 30PM plate thicknesses shows a slight difference of their mechanical properties. This is believed to be because of plates rolling procedure.

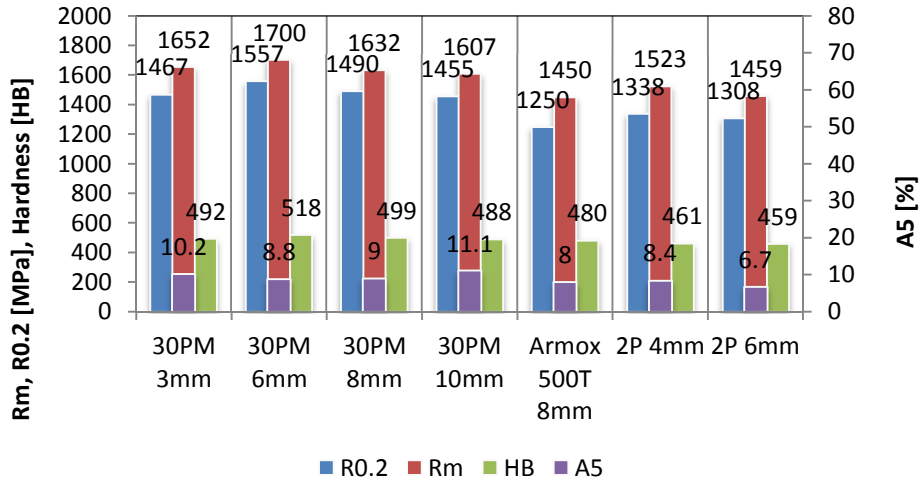

Fig. 6. Comparison of mechanical properties of 30PM armor plates with Armox 500T and 2P steel

### 3. RESULTS AND DISCUSSIONS

#### 3.1. Normal impact of 3 mm plates

In the normal perforation tests of 3 mm thickness steel plates at the initial projectile velocity  $V_i \sim 835$  m/s, the projectile bullets have fully perforated the plates. The damage and failure were localized on the impact zone (see Fig. 7).

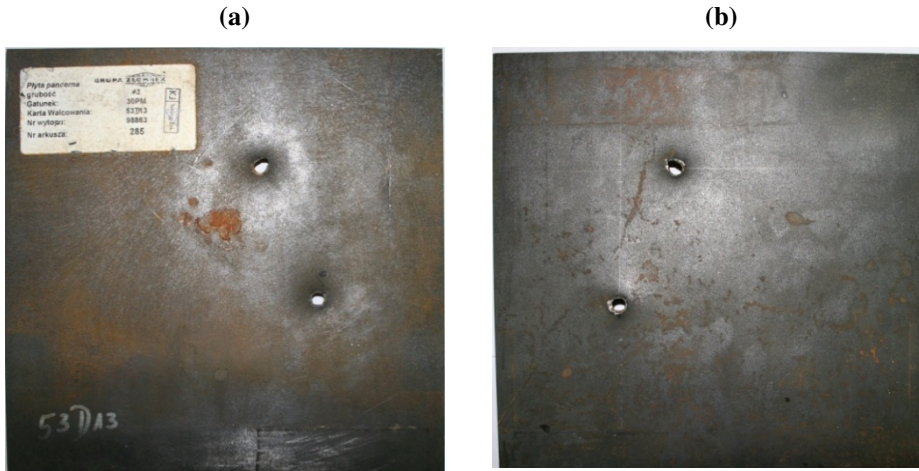
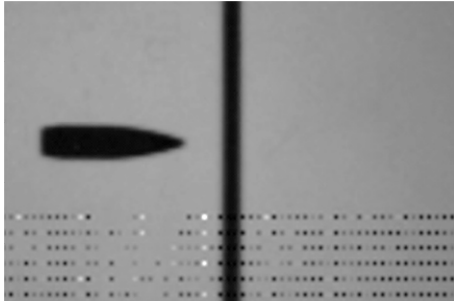

Fig. 7. 30PM steel plates of 3 mm thickness after normal perforation tests (a) impact surface (b) rear surface

Figure 8 shows high speed camera images of perforation tests of 3 mm thickness, and Fig.7 shows the impact surface and the rear surface after the perforation. Note a plate bulging at 23.25  $\mu\text{s}$  and the evidence for its tensile failure at the back surface. In addition, a small plug is formed and ejected.

**t = 0  $\mu\text{s}$**



**23.25  $\mu\text{s}$**

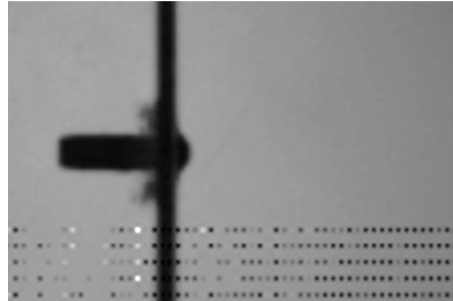

**31  $\mu\text{s}$**



**38.75  $\mu\text{s}$**

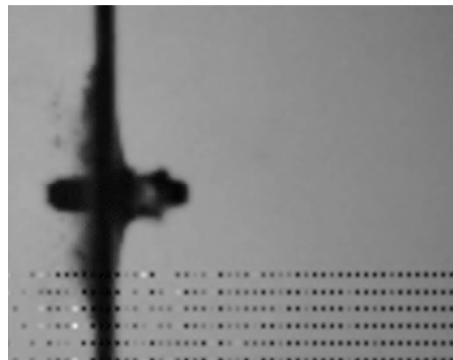

**62  $\mu\text{s}$**

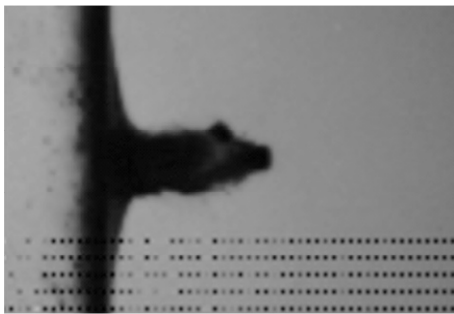

**120.25  $\mu\text{s}$**

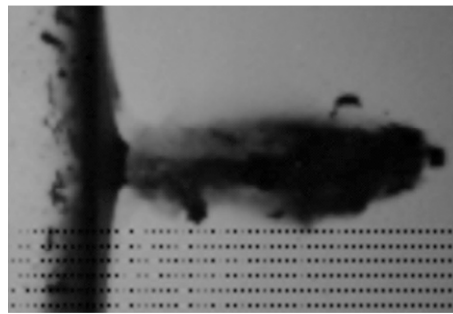

Fig. 8. High speed camera images of perforation tests of 3 mm thickness 30PM steel plates



Figure 9 represents the 7.62 AP bullet core after normal perforation tests of the 3 mm thickness plates. As noticed before, the bullet core is made of N12E steel of high hardness (720 HV).

Based on a visual inspection, the fracture process was mainly brittle for the 720 HV core, and a combined shear fracture and fragmentation mechanisms was obtained. The bullet core length and mass were decreased almost to the half after the impact and perforation of the 3 mm steel plates.

The projectile residual velocity and other measurements of the impact zone of seven shot tests have been done and summarized in Table 2. It can be seen that the 3 mm 30PM steel plates could not provide protection, and the plates have lightly reduced the projectile speed. Due to the small size of the ejected plugs, as seen on the high speed camera images, it was not possible to find them in the rag box.

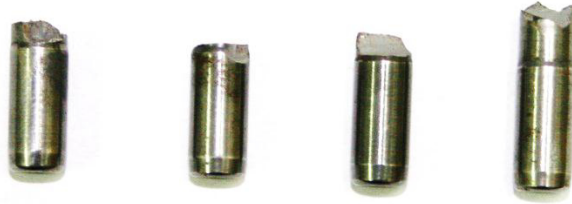

Fig. 9. N12E Bullet core after normal perforation tests of 3 mm thickness plates

Table 2. Measurement results after perforation of 3 mm plates

Test #	Projectile				Target				
	$V_{iop}$ (m/s)	$V_r$ (m/s)	$m_p$ (g)	$\theta$ ( $^\circ$ )	$H_t$ (mm)	$w_{max}$ (mm)	$V_{pl}$ (m/s)	$\phi_{in}$ (mm)	$\phi_{out}$ (mm)
01	840.69	714	3.08	0.0	3.41	8.55	767	6.75	9.15
02	822.03	716	2.33	0.0	3.41	7.46	770	6.71	9.30
03	838.57	727	2.44	0.0	3.30	8.60	777.3	6.80	9.40
04	830.10	720	2.55	0.0	3.41	8.10	772	6.77	9.20
05	833.50	714	2.29	0.0	3.41	8.40	768	6.90	9.30
06	834.40	717	2.90	0.0	3.41	7.60	770	6.85	9.44
07	838.90	716	2.75	0.0	3.41	8.10	768	6.70	9.15

### 3.2. Normal impact of 6 mm plates

The visual inspection of the 6 mm plates after perforation with 7.62 AP projectiles at the ordnance velocity  $\sim 835$  m/s (see Fig. 10-12) and images from the high speed camera images (Fig.13) showed that the steel plates were fully perforated and easily sheared by the high strains around the periphery of the projectile. A plug has been formed and ejected at  $32 \mu\text{s}$  and a small plate deformation has been noticed. The plug length was found to be lower than the plate thickness that can be interpreted as the penetration process starts with initial compression of the impact zone. At a certain depth, the penetration mode changes to the plugging mechanism which is less costly for the projectile, and plug formation and its ejection. The localized plastic zone is clearly seen and the deformation mainly develops in a narrow zone in the target. Outside the localized area, only small deformations are observed.

Also, the small diameter of the crater near the back surface is an indication for high resistance of the target at the later stage of penetration.

After the perforation of the 6 mm plates, the 7.62 AP bullet core residual velocities were decreased almost to the half. The obtained measurement results for 7 shot tests are summarized in Table 3.

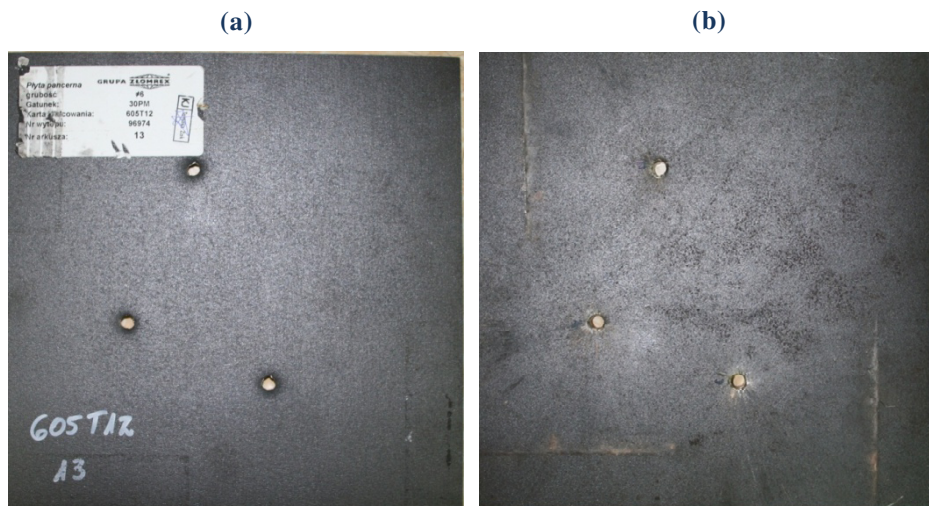

Fig. 10. 30PM steel plates of 6 mm thickness after normal perforation tests (a) impact surface (b) rear surface

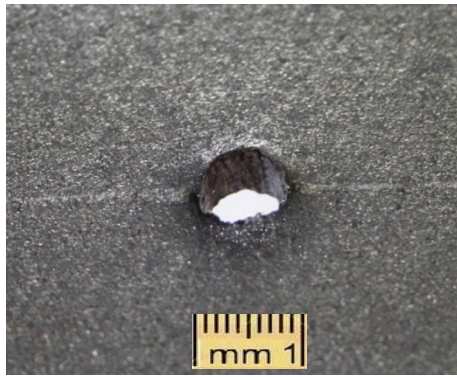

Fig. 11. Generated hole of 6.4 mm 30PM steel plate subjected to blunt-ogival hardened steel core

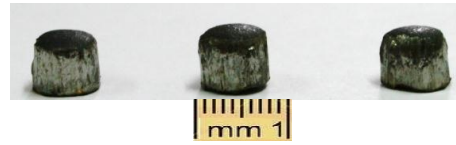

Fig. 12. Resulting plugs after shots of 6.4 mm 30PM steel plates

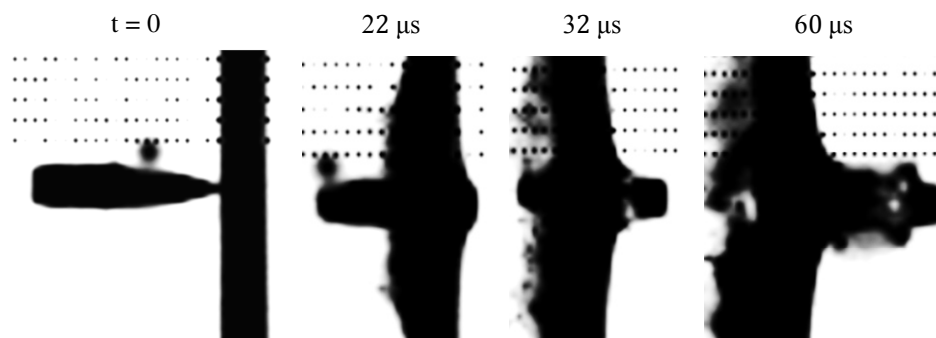

Fig. 13. High speed camera images of perforation tests of 6 mm thickness 30PM steel plates



Fig. 14. Bullet core and resulted plugs after normal perforation of 6 mm thickness plates

Table 3. Measurement results after perforation of 6 mm plates

Test #	Projectile				Target						
	$V_{iop}$ (m/s)	$V_r$ (m/s)	$m_p$ (g)	$\theta$ (°)	$H_t$ (mm)	$w_{max}$ (mm)	$h_{pl}$ (mm)	$m_{pl}$ (g)	$V_{pl}$ (m/s)	$\phi_{in}$ (mm)	$\phi_{out}$ (mm)
08	843.17	445.4	2.54	0.0	6.30	3.38	4.97	1.90	613	9.72	7.30
09	835.07	400	2.12	0.0	6.3	3.9	4.94	1.82	630	10.70	6.93
10	830.91	450	3.44	0.0	6.3	3.69	5.32	1.49	580	10.64	6.01
11	838.93	448.6	f+1.36	0.0	6.49	4.41	5.10	1.75	600.5	10.36	6.58
12	839.98	350.3	2.22	0.0	6.49	4.46	5.21	1.89	470	10.49	7.11
13	833.68	390.90	f+1.5	0.0	6.4	3.77	5.25	1.80	526	10.60	7.05
14	840.33	400.20	2.19	0.0	6.4	4.23	4.99	1.70	536	10.72	6.86

where „f” means that one part of the bullet core was shattered.

Figure 14 represents the 7.62 AP bullet core with the ejected plugs after normal perforation tests of the 6 mm thickness plates. Based on a visual inspection, no considerable plastic deformation was seen on the residual bullet core, and the fracture process was mainly observed. The bullet core length and mass were decreased almost to the half after the impact and perforation of the 6 mm steel plates. These were seen also in the case of 3 mm plate perforation.

### 3.3. Normal impact of 8 plates

The penetration tests of the 8 mm 30PM plates at the ordnance impact velocity 835 m/s showed their resistance to the perforation of 7.62 AP projectiles. A crater was formed with a smooth plate bulging on its back surface (see Fig. 15). After the impact with the plate, the bullet core was shattered to three or four fragments, which proof its brittle behaviour (Fig. 16). The obtained experimental results are presented in Table 4.

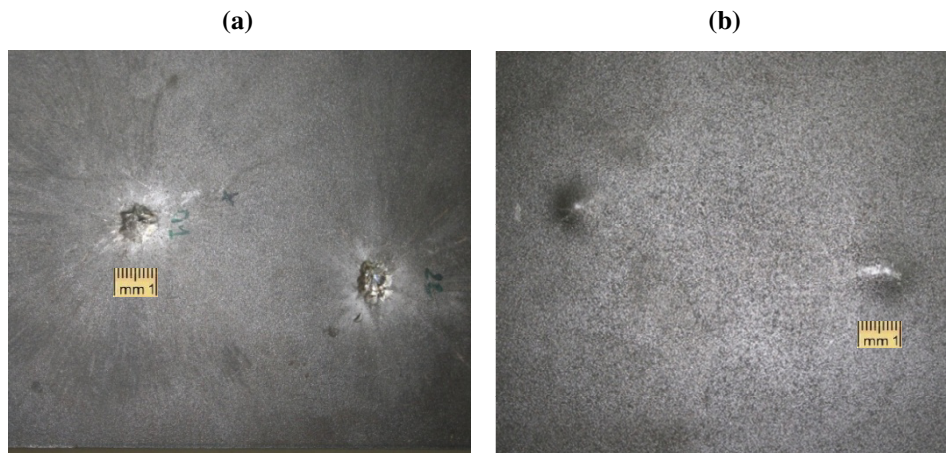

Fig. 15. 30PM steel plates of 8 mm thickness after normal perforation tests (a) impact surface (b) rear surface

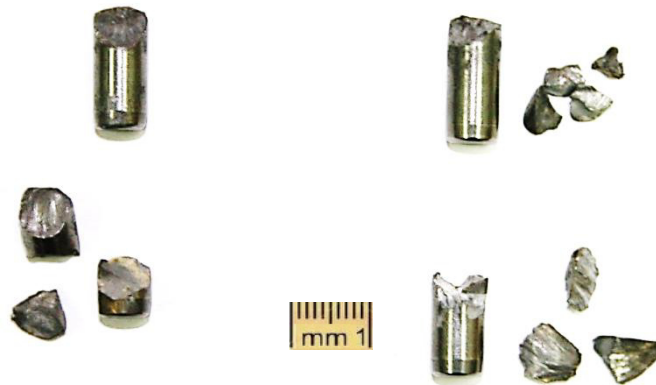

Fig. 16. Bullet core after normal perforation of 8 mm thickness plates

We have seen that the projectile has fully perforated the 6 mm plate, while it has only penetrated  $\sim 2.4$  when the plate thickness is increased to 8 mm. Anderson et al. [4] has experienced similar issue in studying the minimal plate thickness which needs to stop steel rods at a given velocity. As expected, the limiting thicknesses of these plates are higher than the corresponding penetration depths into semi-infinite targets.

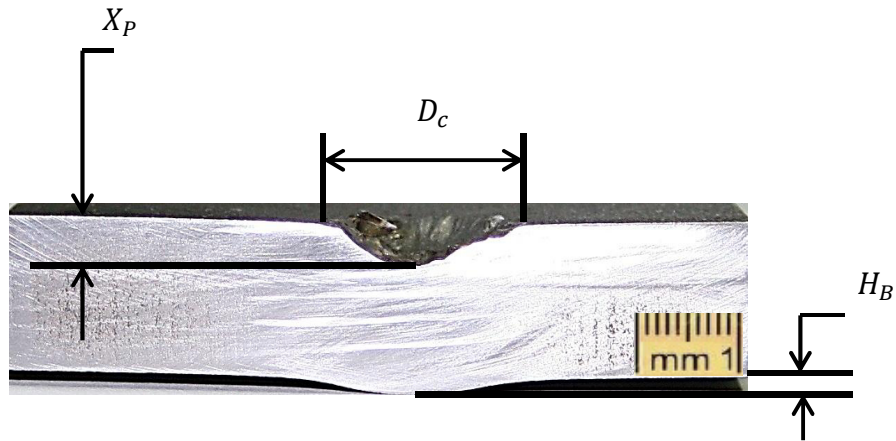

Fig. 17. Cross section of 8 mm plates subjected to normal impact by 7.62 AP projectile with some parameters used in the study

Table 4. Experimental results of penetration of 8 mm steel plates

Test #	Projectile				Target			
	$V_{iop}$ (m/s)	$V_r$ (m/s)	$m_p$ (g)	$\Theta$ (°)	$H_t$ (mm)	$H_B$ (mm)	$X_p$ (mm)	$D_c$ (mm)
15	825.42	0.0	2.12	0.0	8.40	1.1	2.3	11.69
16	840.15	0.0	2.16	0.0	8.40	1.05	2.2	11.70
17	839.28	0.0	2.25	0.0	8.40	1.12	2.35	11.80
18	847.46	0.0	2.27	0.0	8.40	1.96	4.1	11.70
19	834.50	0.0	2.25	0.0	8.40	1.2	2.4	11.65
20	830.90	0.0	2.20	0.0	8.40	1.65	3.4	11.60
21	840.20	0.0	2.26	0.0	8.40	2.01	4.2	11.70

### 3.4. Oblique impact of 3 mm plates

Additional perforation tests were performed on the 3 mm plate at  $50^\circ$  and  $60^\circ$  of obliquity. The  $60^\circ$  angle is considered as the NATO angle used in armored vehicles to defeat small arms projectiles. However, the  $50^\circ$  angle was chosen arbitrary as an angle lower than the limit perforation angle.

### 3.4.1. Impact at 50° obliquity

The experimental results of the penetration of 30PM steel plates at 50° obliquity show a full perforation of the 30PM steel plates at 50° of obliquity (Fig. 18) and a drop of the bullet residual velocity due to the increase in effective plate thickness.

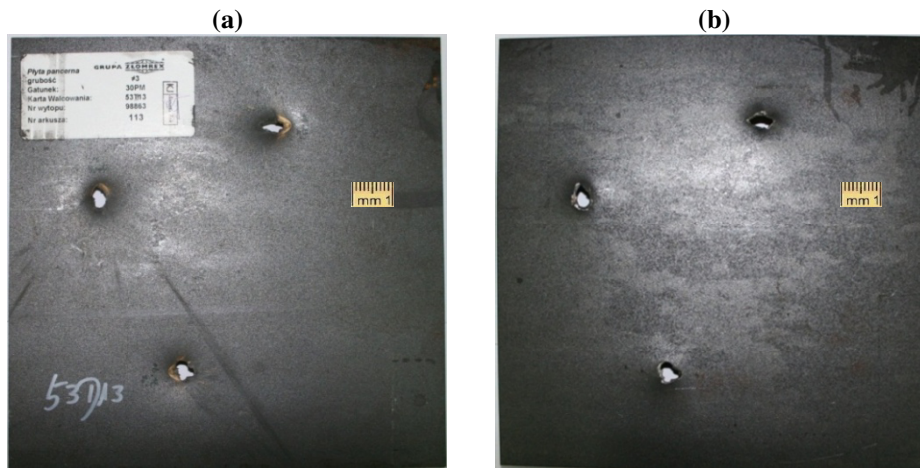

Fig. 18. 30PM steel plates of 3 mm thickness after 50° oblique perforation tests (a) impact surface (b) rear surface

According to high speed camera images presented in Fig. 19, the penetration process starts with plate bulging, then stretching. After that, the projectile could fully perforate the plate due to tensile failure mechanism. Figure 20 shows the plate behaviour with some parameters studied in oblique situation.

The experimental results obtained from perforation tests at 50° obliquity were presented in Table 5.

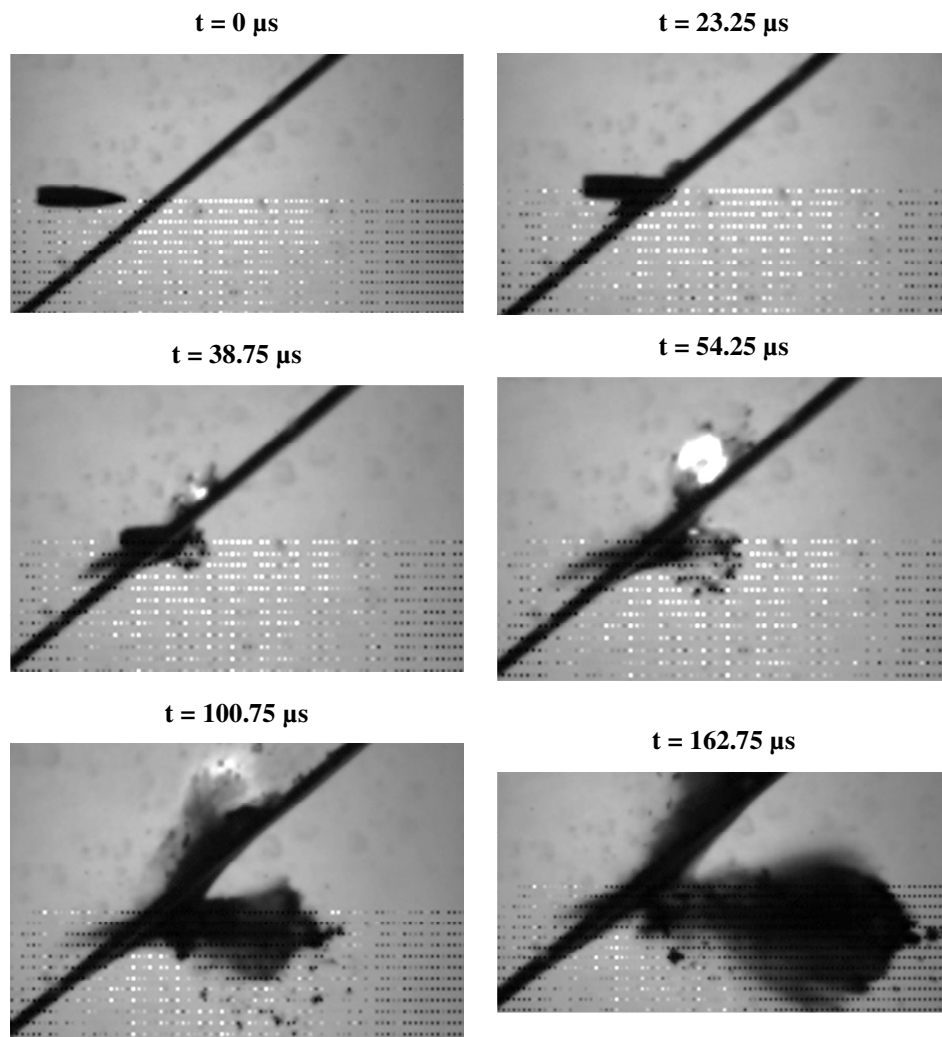

Fig. 19. High speed camera images of 50° oblique perforation tests of 3 mm thickness 30PM steel plates

The visual inspection of the bullet residual core shows that the high hardness steel core is deformed very little plastically prior to fracture (see Fig. 21). This is believed to be that the bullet core was subjected to greater bending stresses due to oblique impact.



Table 5. Experimental results of penetration of 3 mm steel plates at 50° obliquity

Test #	Projectile					Target				
	$V_{iop}$ (m/s)	$V_r$ (m/s)	$m_p$ (g)	$\Theta$ (°)	$\varphi_D$ (°)	$w_{max}$ (mm)	$H_t$ (mm)	$D_c$ (mm)	$D_b$ (mm)	$D_r$ (mm)
22	830.22	180.10	f	50	16.20	12.2	3.50	15.49	6.03	15.35
23	834.37	172	f	50	18.10	11.7	3.24	13.69	7.30	15.02
24	820.34	181.50	f+2.08	50	25.00	11.85	3.24	14.48	7.27	15.40
25	834.03	185	c	50	17.50	12.12	3.24	12.85	7.40	15.53
26	839.28	171.40	f+1.28	50	18	10.05	3.43	14.12	6.03	13.05
27	825.42	190.20	f+1.73	50	20	10.49	3.43	13.60	6.06	13.00
28	829.53	175.90	f+1.83	50	15.45	11.89	3.43	12.18	6.03	13.04

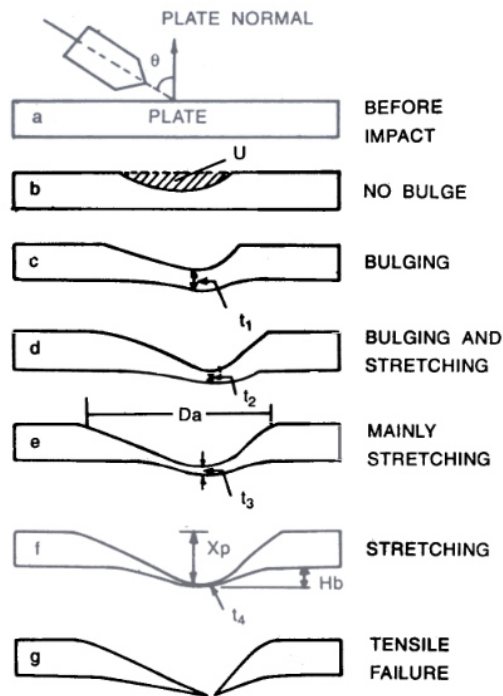

Fig. 20. Plate behaviour with some parameters studied in oblique situation



Fig. 21. Bullet core after 50° oblique perforation tests

### 3.4.2. Impact at 60° obliquity

At 60°, the penetration process changes from perforation to ricochet due to the large asymmetric forces applied to the projectile. The bullet just slides over the target surface causing plate damage before it rebounds without perforation (see Fig. 22 and Fig. 23). The plate damage is believed to be because of the normal component of the striking velocity.

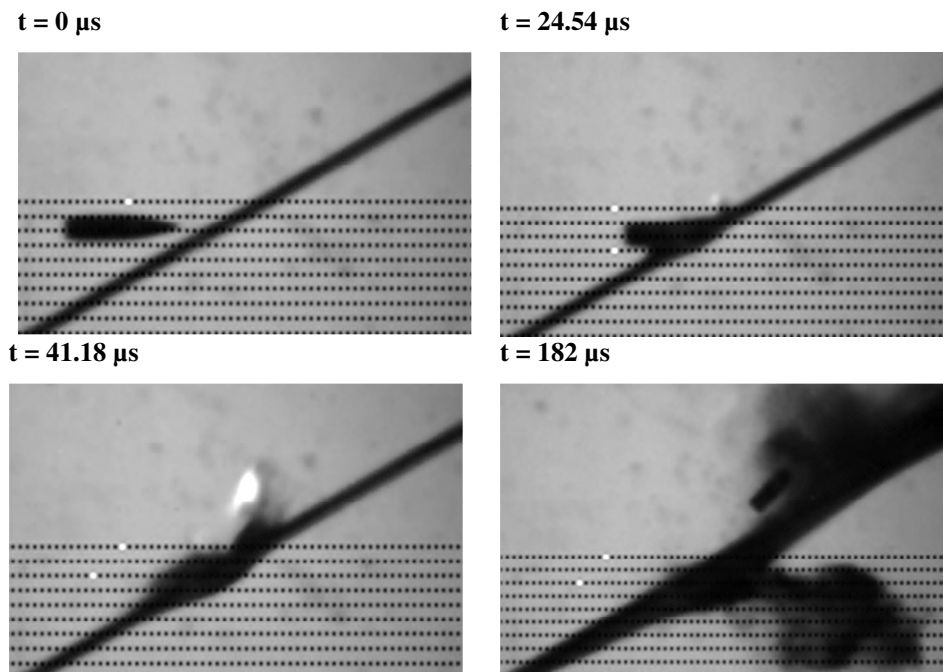

Fig. 22. High speed camera images of 60° oblique perforation tests of 3 mm thickness 30PM steel plates

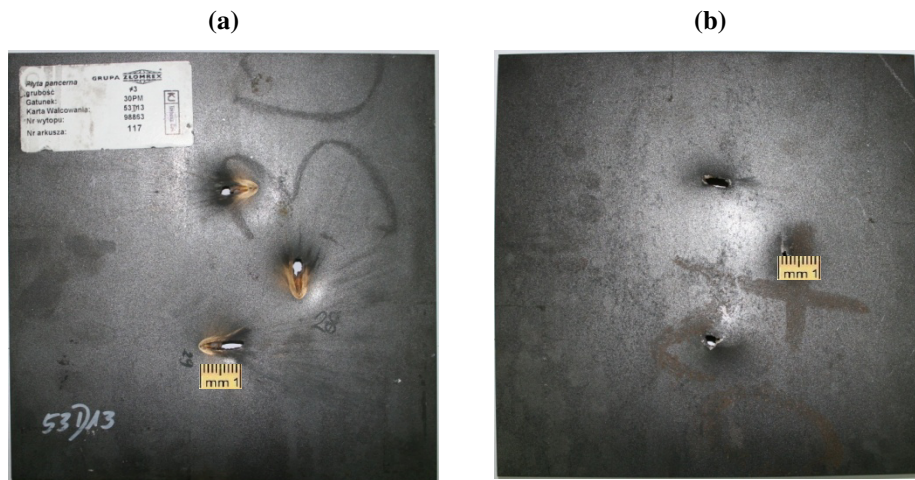

Fig. 23. 30PM steel plates of 3 mm thickness after 60° oblique perforation tests (a) impact surface (b) rear surface

Figure 24 shows the residual bullet core where it is clear that the projectile was fractured and a small plastic deformation can be seen in some parts due to the bending stresses applied on the projectile during the impact.



Fig. 24. Bullet core after 60° oblique perforation tests

The experimental results obtained from perforation tests at 60° obliquity were presented in Table 6.

Table 6. Experimental results of penetration of 3 mm steel plates at 60° obliquity

Test #	Projectile					Target				
	$V_{iop}$ (m/s)	$V_r$ (m/s)	$m_p$ (g)	$\theta$ (°)	$\varphi_R$ (°)	$w_{max}$ (mm)	$H_t$ (mm)	$D_c$ (mm)	$D_b$ (mm)	$D_r$ (mm)
29	822.03	510	a	60	75	12.67	3.30	23.50	6.66	16.66
30	832.64	460	a	60	80	14.7	3.50	24.28	5.71	16.60
31	832.64	475	f+2.10	60	79	14.3	3.50	17.17	5.90	15.80
32	838.92	400	f+0.89	60	80.28	15.5	3.4	23.60	6.05	16.05
33	839.28	480	f+1.27	60	78.8	13.86	3.4	23.00	5.75	16.90
34	829.53	440	c	60	75.5	15.28	3.4	19.56	6.01	15.30
35	823.4	490	2.75	60	70.2	14.81	3.35	22.53	6.04	16.80

“a” Projectile embedded in the sabot trap (because of ricochet)

“c” Lost in the rag box

#### 4. CONCLUSION

The penetration process of 30PM steel plates, which provide high strength and hardness by an Armor Piercing projectile, found to be complex due to the geometries of the projectile and target, such as irregular shapes and oblique impact, projectile erosion and fragmentation. Moreover, several fracture mechanisms took place, depending on the condition of interaction between the projectile and the plate. According to the laboratory investigations on the perforation of 30PM armor steel, the following main conclusions can be drawn:

- The experimental set-up developed to apply the ballistic tests program is an excellent tool for carrying impact tests using real ammunition launched from a laboratory gun at the ordnance velocity.
- The results of laboratory tests showed that the Polish hard armor steel plates made of 30PM steel have positive ballistic performance against armor piercing projectile (7.62 × 51 mm AP). The results of laboratory tests showed also the capacity and research potential of the Institute of Armament Technology at the Military University of Technology.
- Experimental results from perforation and penetration tests have shown to be suitable for verification and validation of terminal ballistics models, since both the projectile residual velocity and path, and failure modes may easily be changed by varying different impact conditions, such as the plate thickness and the plate obliquity.

- The obtained experimental results may also serve as a reference results for analyzing various models and numerical techniques accessible in commercially available hydrocodes. They can be also used for testing new models, including some analytical or semi-analytical models.

## REFERENCES

- [1] Gama A. Bazle, Travis A. Bogetti, Bruce K. Fink, Chin-Jye Yu, T.Dennis Claar, Harald H. Eifert, John W. Gillespie Jr. 2001. „Aluminum foam integral armor: a new dimension in armor design”. *Composite Structures* 52 : 381-95.
- [2] Cheeseman A. Bryan, Travis A. Bogetti. 2003. „Ballistic impact into fabric and compliant composite laminates”. *Composite Structures* 61 : 161-73.
- [3] Woodward R.L. 1990. Material failure at high strain rates. In *High Velocity Impact Dynamics* (Ed. Zukas J.A.), 65-126. New York: John-Wiley and Sons, Inc.
- [4] Anderson L. Ted. 1991. *Fracture Mechanics (Fundamentals and Applications)*. CRC Press, Inc.
- [5] Borvik Tore, Lars Olovsson, Subhankar Dey, Magnus Langseth. 2011. „Normal and oblique impact of small arms bullets on AA6082-T4 aluminum protective plates”. *Int J Impact Eng.* 38 : 577-589.
- [6] Skoglund P., M. Nilsson, A. Tjernberg. 2006. „Fracture modeling of a high performance armour steel”. *J. Phys.* 134 : 197-202.
- [7] Buchar J., J. Voldrich, S. Rolc, J. Lisy. 2002. Ballistic performance of dual hardness armor. In *Proceedings of the 20th International Symposium on Ballistics*, 23-27.
- [8] Chocron Sidney, Chales E. Anderson, Donald Grosch, Carl H. Popelar. 2001. „Impact of the 7.62 mm APM2 projectile against the edge of a metallic target”. *Int. J. Impact Eng.* 25 : 423-37.
- [9] Kılıç Namik., Bülent Ekici. 2013. „Ballistic resistance of high hardness armor steels against 7.62 mm armor piercing projectile”. *Materials and Design* 44 : 35-48.
- [10] Starczewski Lech 2009. *A comparison study of 30PM and PM450 steel plates with Armox 500T and 440T according to their ballistic limit velocity V50* [in Polish]. Report of WITPiS, No 27/ZE/2009, Sulejów, Poland.
- [11] Starczewski Lech, Stanisław Szczęch. 2001. *Opracowanie i wdrożenie do produkcji nowego gatunku stali na osłony balistyczne pojazdów wojskowych i sprzętu uzbrojenia*, – Raport końcowy z realizacji projektu celowego nr 4753 Stalowa Wola-Sulejów.

