

## STABILIZATION MECHANISM FOR HELICOPTER PAD WITH FOUR DEGREES OF FREEDOM

Damian Brewczyński, Grzegorz Tora

Cracow University of Technology  
Faculty of Mechanical Engineering, Institute of Machine Design  
Jana Pawła II Avenue 37, 31-864 Krakow, Poland  
tel.: +48 12 6283406, +48 12 6283408, fax: +48 12 3743360  
e-mail: brewczyn@mech.pk.edu.pl, tora@mech.pk.edu.pl

### Abstract

*Helipad located on ships greatly increases their ability to perform tactical and logistical abilities. They allow performing reconnaissance from the air, transportation of cargos and people to and from the ship. Landing on a moving ship particularly small size during bad weather is not a safe manoeuvre. Article provides an overview of existing solutions that improve safety during the landing manoeuvre of the helicopter to the ship and describes an innovative mechanism with can stabilize helicopter pad in four degrees of freedom. This solution is characterized in that the landing plate is movable and actuated simultaneously by two support plates and two levers. Plates and levers are driven by separate linear motors that move along the guides connected to the base. The main feature of the mechanism is that when the base is not stable, it can reduce the linear movement of the landing platform in the vertical and transverse direction and angular displacement around an axis perpendicular and parallel to the axis of the ship. A preferred feature of the mechanism is that in folded position it occupies relatively little space. In addition, advantageous attribute of the mechanism is its large working area, enabling the reduction of high amplitude vibration. The article contains a calculation of the kinematics for the proposed structure of the mechanism. It also includes speed drives waveforms, which are the result of simulations for the input parameters of the ship movement.*

**Keywords:** mechanical engineering, maritime engineering, kinematic analysis, mechanism design, safety

### 1. Introduction

Marine and ocean-going ships are often equipped with a helicopter pad. Landing a helicopter on a moving ship during bad weather brings with it a number of dangers. The main threats may include; contact blades of the main rotor of the helicopter with helipad plate, uneven approach the helicopter relative to the ship moving in by waves and damage of helicopter caused a hard hit on the landing platform. This paper contains an overview of available solutions designed to improve safety during the helicopter approach to landing pad on the ship and it proposed new kinematic system that complies the established criteria, the kinematics model and determination of the temporary drives speed in design mechanism.

In the literature and patents can be found systems improving safety during the landing of helicopters on the ship. One of the available solutions is a system for tracking and guidance on the correct path helicopter approaches using signal lamps “CILAS HVLAS Helicopter Visual Landing Aid System” [9]. The pilot approaching to helipad trying to keep path of helicopter movement in visible green beam of light, sent by the stabilized emitter from the ship. Position of the helicopter is tracked by the system and the pilot is receiving information about the possible need for adjustments in approach path.

Another solution is a system proposed by JL López Sánchez [5], relies on optical tracking position of the symbol “H” on the helipad by cameras mounted on the helicopter and automatic flight control of the helicopter. Image analysis allows for automatic identification of the location and orientation in space relative to a helicopter-landing pad (Fig. 1). This information is used to assist in controlling the landing of the helicopter.

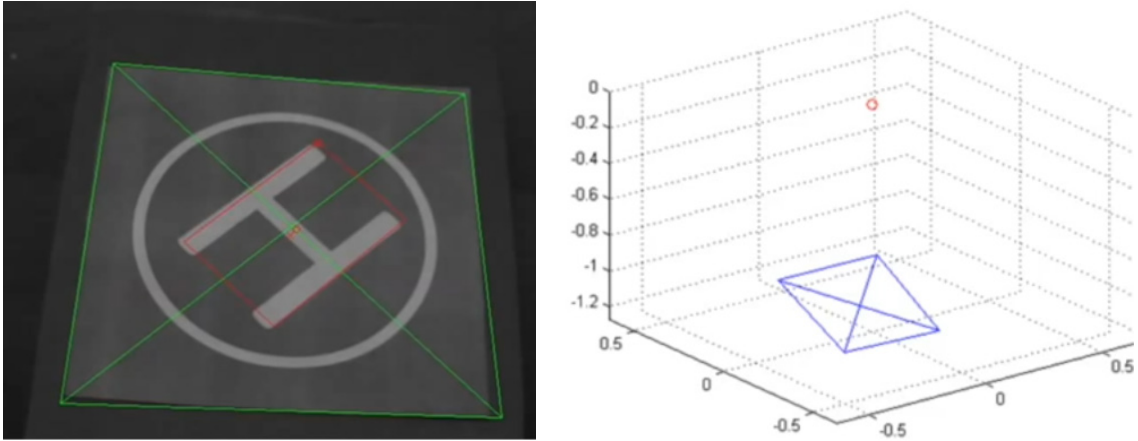

Fig. 1. View from the helicopter camera and visualization of helipad position in space

Another solution is the system proposed by the Prism Defence Company [10]. It studying the safe boundary conditions for cooperation between ship and helicopter. As can guess the system relies on movement measurements performed by the ship, helicopter, ship's closest environment and it the use these data in real-time to calculate and predict the right moment for a safe landing.

The above helicopter landing support systems may be supplemented by a system of movable landing pad [10], which reduces the landing position changes caused by rocking of the ship in one direction along the transverse axis of the ship (Fig 2.).

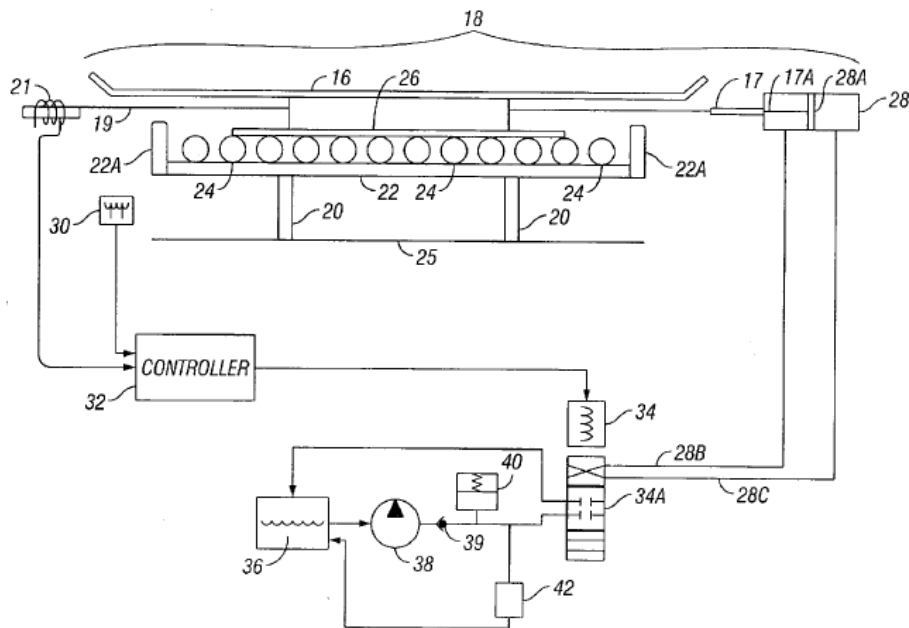

Fig. 2. Illustration of the patent US 2010/0224118 A1

## 2. Scheme of the stabilization mechanism for helicopter pad

The mechanism (Fig. 3) consists of a landing plate 10 actuated via supporting plates 5 and 6 and the levers 7 and 8. The supporting plates 5, 6 and the lever 8 are connected with the landing plate 10 by cross joint D, E, I. The plate 6 is connected with a linear drive 3 by a joint C, while plate 5 is connected with a linear drive 2 by joint B. The lever 8 is connected with a linear drive 1 by joint A. The lever 7 is connected to drive 4 by joint G, and to the landing plate 10 by ball joint F. Linear drive 4 moves along the guide 9c, linear drives 1, 2 and 3 moves along the guides 9a and 9b. The guides 9a, 9b and 9c are fixedly connected to the base of landing mounted to the ship.

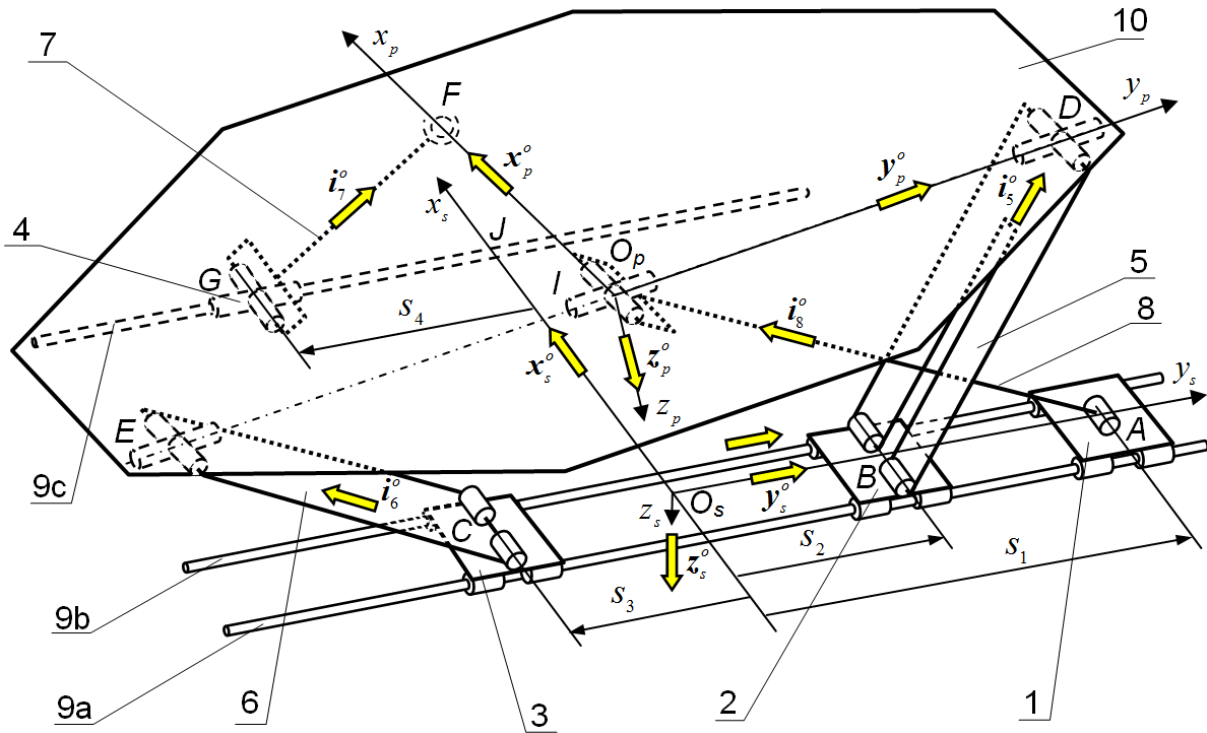

Fig. 3. Scheme of the stabilization mechanism for helicopter pad with four degrees of freedom

In folded state mechanism occupies relatively little space under the deck (Fig. 4). Before landing or take-off of helicopter, the linear drives (Fig. 5) set up a helipad in the middle of its workspace.

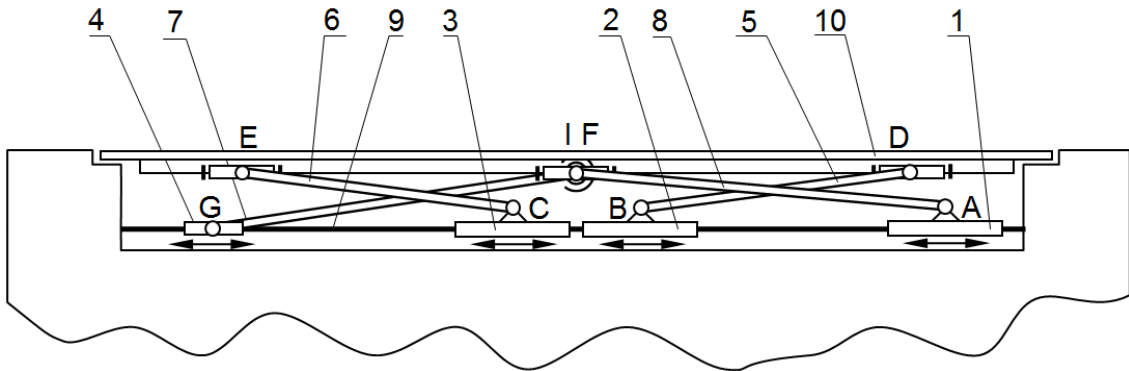

Fig. 4. Stabilization mechanism for helicopter pad in folded state (view from the stern of the ship)

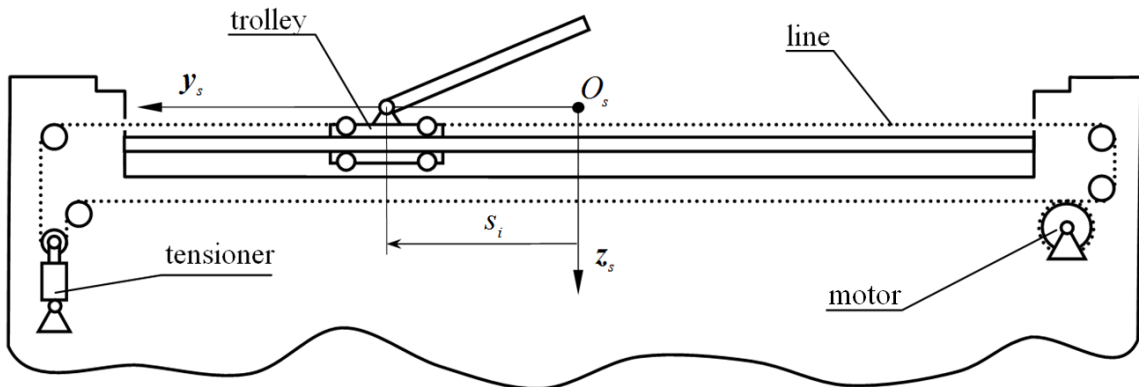

Fig. 5. Single drive scheme (cross section across the ship)

### 3. Kinematics of the helicopter pad stabilization mechanism

Kinematics calculation of the helicopter pad stabilization mechanism equipped with 4 independent drives is as follows:

$$s_1 y_s^o + l_8 i_8^o = r_{O_s O_p}, \quad (1)$$

where:

$s_1$  – distance of trolley 1 from the centre of ship reference system  $O_s$ ,

$y_s^o$  – axis  $y_s$  unit vector of ships reference system,

$l_8$  – length of the link 8,

$i_8^o$  – directional unit vector of link 8,

$r_{O_s O_p}$  – vector from the centre of ship reference system  $O_s$  to centre of helipad reference system  $O_p$ ,

$$s_2 y_s^o + l_5 i_5^o - l_{O_p D} y_p^o = r_{O_s O_p}, \quad (2)$$

where:

$s_2$  – distance of trolley 2 from the centre of ship reference system  $O_s$ ,

$l_5$  – length of the link 5,

$i_5^o$  – directional unit vector of link 5,

$l_{O_p D}$  – distance between points  $O_p$  and  $D$ ,

$y_p^o$  – axis  $y_p$  unit vector of helipad reference system,

$$s_3 y_s^o + l_6 i_6^o + l_{O_p E} y_p^o = r_{O_s O_p}, \quad (3)$$

where:

$s_3$  – distance of trolley 3 from the centre of ship reference system  $O_s$ ,

$l_6$  – length of the link 6,

$i_6^o$  – directional unit vector of link 6,

$l_{O_p E}$  – distance between points  $O_p$  and  $E$ ,

$$l_{O_s J} x_s^o + s_4 y_s^o + l_7 i_7^o - l_{O_p F} x_p^o = r_{O_s O_p}, \quad (4)$$

where:

$l_{O_s J}$  – distance between points  $O_s$  and  $J$ ,

$x_s^o$  – axis  $x_s$  unit vector of ship reference system,

$s_4$  – distance of trolley 4 from the centre of ship reference system  $O_s$ ,

$l_7$  – length of the link 7,

$i_7^o$  – directional unit vector of link 7,

$l_{O_p F}$  – distance between points  $O_p$  and  $F$ ,

$x_p^o$  – axis  $x_p$  unit vector of helipad reference system,

If derivatives of equations (1-4) will be, express in ships reference system, then

$$\omega_s = 0, v_{O_s} = 0.$$

After differentiation of equations system (1), (2), (3), (4) and projected onto the directions of the support, temporary drives speed have been received (5-8):

$$v_1 = \frac{v_{O_p} \cdot i_8^o}{y_s^o \cdot i_8^o}, \quad (5)$$

where:

$v_1$  – velocity of the trolley 1,

$v_{O_p}$  – velocity vector of helipad reference system  $O_p$  relative to the centre of ship reference system,

$$v_2 = \frac{[v_{O_p} + l_{O_p D}(\omega_p \times y_p^o)] \cdot i_5^o}{y_s^o \cdot i_5^o}, \quad (6)$$

where:

$v_2$  – velocity of the trolley 2,

$\omega_p$  – the angular velocity vector of helipad in the ships reference system,

$$v_3 = \frac{[v_{O_p} + l_{O_p E}(\omega_p \times y_p^o)] \cdot i_6^o}{y_s^o \cdot i_6^o}, \quad (7)$$

where:

$v_3$  – velocity of the trolley 3,

$$v_4 = \frac{[v_{O_p} + l_{O_p F}(\omega_p \times x_p^o)] \cdot i_7^o}{y_s^o \cdot i_7^o}, \quad (8)$$

where:

$v_4$  – velocity of the trolley 4.

The helipad will not rotate around the axis  $x_p$ ,  $y_p$  and will not move along the axis  $y_p$  and  $z_p$  when the following conditions (9) and (10) are fulfilled:

$$\omega_p = -[\omega_s^g - (\omega_s^g \cdot z_p^o) z_p^o], \quad (9)$$

where:

$\omega_s^g$  – the angular velocity vector of the ship in motionless reference system,

$$v_{O_p} = -[v_{O_s}^g - (v_{O_s}^g \cdot x_s^o) x_s^o], \quad (10)$$

where:

$v_{O_s}^g$  – the linear velocity vector of ship reference system in motionless reference system

## 4. Results

Based on observations of the naval unit Knud Rasmussen-class patrol vessel the following parameters in the simulation were adopted:

- simulation time:  $T = 100$  s,
- simulation step: 0.05 s,
- helicopter pad dimension: 22 m,
- links dimensions:  $l_4 = 12$  m,  $l_5 = l_6 = l_7 = 8$  m,  $l_{O_p F} = l_{O_s J} = 11$  m,
- rocking of the ship parameters:  $\nu = 0.14$  Hz,  $T = 7.14$  s,  
 $\omega_x = 0.3 \cos(1.143 \nu t)$  rad/s,  $\omega_y = 0.1 \cos(\nu t)$  rad/s,  $\nu_z = 0.21 \cos(\nu t)$  m/s.

Simulation results:

- tilts range:  $\Delta \alpha_x = 0.374r$ ,  $\Delta \alpha_y = 0.145r$ ,  $\Delta \alpha_z = 0.021r$ ,
- displacements range  $O_s$ :  $\Delta O_{sx} = 1.15$  m,  $\Delta O_{sy} = 3.02$  m,  $\Delta O_{sz} = 3.19$  m,
- displacements range of drives:  $\Delta s_1 = 5.13$  m,  $\Delta s_2 = 4.66$  m,  $\Delta s_3 = 3.31$  m,  $\Delta s_4 = 5.79$  m.

## 5. Conclusion

Preliminary simulation results for adopted conditions show that the momentary drives speed values do not exceed 0.31 m/s (Fig. 6). The speed at this level can be achieved by designing line

drives moved by electric motors. In order to design drives, it is necessary to obtain information about the drives (Fig. 5) loads.

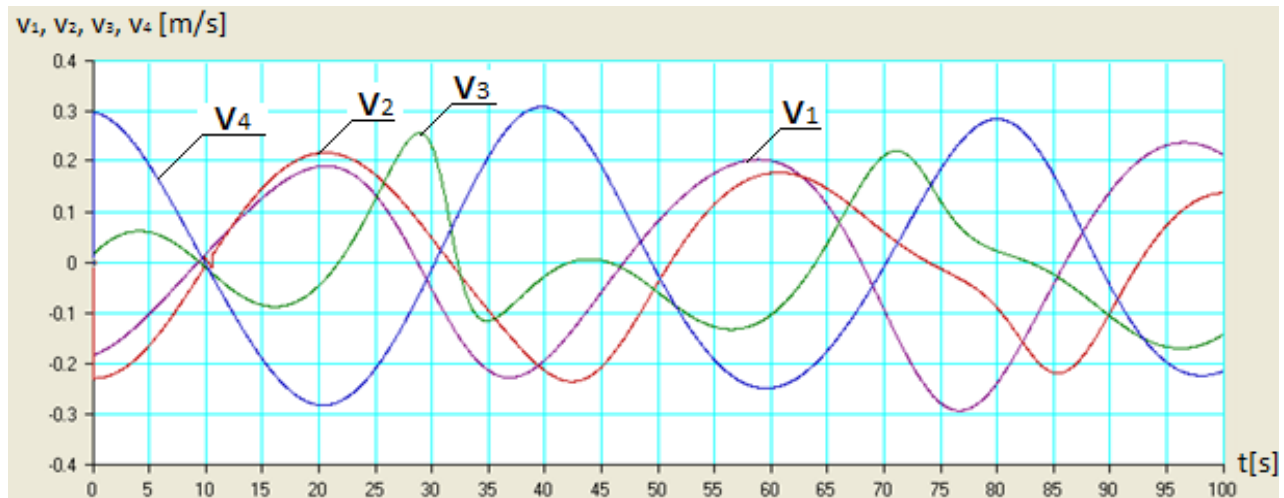

Fig. 6. Graph: drives speed  $v_1, v_2, v_3, v_4$  as a function of time

Compared to the previous solution [2] a significant complication of the proposed mechanism structure can be observed, which was necessary to enable reduction of the helipads tilts about the transverse axis of the ship.

The expansion of a computer model is planned which takes into account the load and supplemented by models of drives. Full computer model will be the basis for building a physical model in scale.

## References

- [1] Patent: US 2010/0224118 A1, *Helicopter Landing Platform Having Motion Stabilizer for Compensating Ship Roll and/or Pitch*, 2010.
- [2] Brewczyński, D., Tora, G., *Dynamic positioning system of helicopter pad on the ship*, Journal of KONES Powertrain and Transport, Vol. 21, No. 4, pp. 21-27, 2014.
- [3] Dasgupta, B., Choudhury, P., *A general strategy based on the Newton-Euler approach for the dynamic formulation of parallel manipulators*, Mechanism and Machine Theory, Vol. 34, pp. 801-824, 1999.
- [4] Ider, S. K., *Inverse dynamics of parallel manipulators in the presence of drive singularities*, Mechanism and Machine Theory, Vol. 40, pp. 33-44, 2005.
- [5] Sanchez-Lopez, J. L., Pestana, J., Saripalli, S., Campoy, P., *An approach toward visual autonomous ship board landing of a VTOL UAV*, J. Intell. Robot Syst., Vol. 74, pp. 113-127, 2014.
- [6] Tora, G., *Modeling a platform mechanism of active cab suspension in heavy duty machines*, Publisher PK, 2012.
- [7] Tora, G., *Mechanizm stabilizujący ruchome lądowisko helikopterów*, patent Application No. P.411005, 2014.
- [8] Tsai, L.-W., *Solving the inverse dynamics of a Stewart-Gough manipulator by the principle of virtual work*, Journal of Mechanical Design, Vol. 122, pp. 3-9, 2000.
- [9] CILAS HVLAS Helicopter Visual Landing Aid System, <http://www.cilas.com/helicopter-visual-landing-aids.htm>.
- [10] Prism Defence company that develops support systems for helicopters landing on the ships: [www.prismdefence.com/index.html](http://www.prismdefence.com/index.html).