

Noise Characterization of Differential Multi-Element Multiport Networks - the Wave Approach

Janusz A. Dobrowolski

Abstract—In this paper there is presented and discussed a general analysis method for noise characterization of noisy multi-element multiport differential networks. It is based on mixed mode, differential and common mode, noise waves representation of noise, generalized mixed-mode scattering parameters and generalized mixed-mode noise wave correlation parameters for the network. There are derived analytical relation between the noise figure for a given output port and the noise matrix and the scattering parameters of the network, as well as the correlations between the input port noise waves. The signal to noise ratio degradation factor is derived and discussed, too. Presented results can be implemented directly in a CAD software for noise analysis of differential microwave multi-element multiport networks with differential as well as with conventional single ended ports.

Keywords—differential networks, differential noise figure, noise waves, noise correlation matrix

I. INTRODUCTION

MANY present day RF and microwave networks are implemented as differential networks. In comparison to standard single ended networks, differential are more resistible against external disturbances and noise, particularly supply and ground noise. Differential networks require special tools for characterization, analysis and design. D. Bockelman and W.R. Eisenstadt [1] have introduced so-called mixed-mode waves (wave variables) and mixed mode scattering parameters to extend the classical single-ended wave approach to the differential case. In 2006, A. Ferrero and M. Pirolla [2] introduced generalized mixed-mode scattering matrix which can be used for hybrid networks having some ports differential and some ports single-ended. Such theory may be used for characterization and signal analysis and design of differential networks containing differential amplifiers, baluns, transformers etc.

The noise wave formalism has been applied for years to study noise properties of single ended two-port devices and networks [3-6] and multi-port networks [8-9]. J. Randa [9] has proposed a way to apply single-ended noise waves and standard single-ended scattering parameters to derive noise parameters of differential multiport networks. In [12-15] mixed mode noise wave formalism and mixed mode S parameters are applied to derive the differential noise figure of four port differential networks.

J.A. Dobrowolski is with the Warsaw University of Technology, Institute of Electronic Systems, Warsaw, Poland (email: j.dobrowolski@ise.pw.edu.pl).

In this paper there is presented a general noise analysis method which is based on mixed mode, differential- and common-mode, noise wave formalism [7] derived from pseudowave definition presented in [3] by R. Marks and D. Williams, the generalized mixed-mode scattering matrix [2] and the mixed mode noise wave correlation matrix [7]. Presented approach may be used for noise analysis of differential networks with mixed mode ports as well as with single-ended ports. It is applicable to networks considered as a connection of many noisy multiport elements with mixed-mode, differential- and common-mode ports as well as with single-ended ports, described separately by their generalized mixed mode scattering matrices and the generalized mixed-mode noise wave correlation matrices.

The method is applied to evaluate the differential noise figure and the differential signal to noise ratio degradation factor of mixed mode multi-element multiport networks. Derived and presented in this paper analytical expressions for noise parameters of differential networks can be implemented in a CAD software.

Presented here noise analysis theory corresponds to another general purpose noise analysis method applicable to microwave networks which are modeled as single multiports with mixed-mode, differential- and common-mode ports as well as with single-ended ports closed by appropriate signal sources and loads [16].

II. NOISE ANALYSIS OF MIXED-MODE MULTI-ELEMENT MULTI-PORT NETWORKS

Figure 1 presents a general noisy multi-element multiport network with noiseless elements and equivalent noise pseudowave sources at each port. Each element of the network is represented by its noiseless equivalent having the same generalized mixed-mode scattering matrix as the original element [2], while noise generated in each element is represented by correlated equivalent noise pseudowave sources, one source at each port. Some ports of the network elements are coupled, forming differential/common, mixed-mode ports, while the other ports are standard, single-ended ports [7]. The mixed-mode ports of some elements are connected with the mixed-mode ports of other elements of the network and similarly, the single-ended ports of some elements are connected with the single-ended ports of other elements.

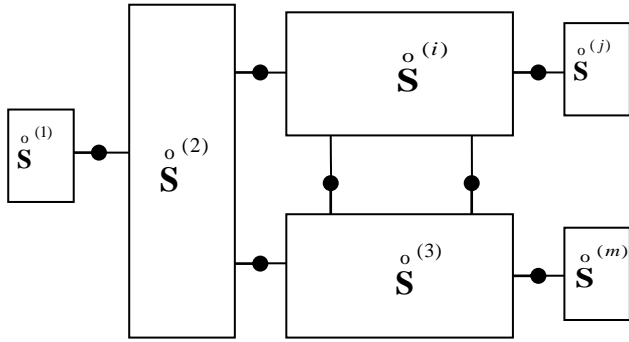

Fig. 1. Noisy multi-element multiport network

In matrix notation, a set of linear equations that relates complex amplitudes of noise pseudowaves at ports of a network element has a form [4,8]

$$\mathbf{b}^{o(k)} = \mathbf{S}^{o(k)} \mathbf{a}^{o(k)} + \mathbf{c}^{o(k)} \quad (1)$$

where $\mathbf{S}^{o(k)}$ is the generalized mixed-mode scattering matrix of the k th element [2], $\mathbf{a}^{o(k)}$ and $\mathbf{b}^{o(k)}$ are vectors of the ingoing and outgoing noise pseudowaves at its ports [1,3,7], and $\mathbf{c}^{o(k)}$ is a vector of the correlated noise pseudowave sources representing noise generated in the k th element of the network:

$$\mathbf{a}^{o(k)} = \begin{bmatrix} \mathbf{a}_d^{(k)} \\ \mathbf{a}_c^{(k)} \\ \mathbf{a}_e^{(k)} \end{bmatrix} \quad \mathbf{b}^{o(k)} = \begin{bmatrix} \mathbf{b}_d^{(k)} \\ \mathbf{b}_c^{(k)} \\ \mathbf{b}_e^{(k)} \end{bmatrix} \quad \mathbf{c}^{o(k)} = \begin{bmatrix} \mathbf{c}_d^{(k)} \\ \mathbf{c}_c^{(k)} \\ \mathbf{c}_e^{(k)} \end{bmatrix} \quad (2)$$

and

$$\mathbf{S}^{o(k)} = \begin{bmatrix} \mathbf{S}_{dd}^{(k)} & \mathbf{S}_{dc}^{(k)} & \mathbf{S}_{de}^{(k)} \\ \mathbf{S}_{cd}^{(k)} & \mathbf{S}_{cc}^{(k)} & \mathbf{S}_{ce}^{(k)} \\ \mathbf{S}_{ed}^{(k)} & \mathbf{S}_{ec}^{(k)} & \mathbf{S}_{ee}^{(k)} \end{bmatrix} \quad (3)$$

In (2), the sub-vectors with lower indexes “d” correspond to the differential-mode noise pseudowaves and the equivalent noise pseudowave sources, the sub-vectors with lower indexes “c” correspond to the common-mode noise pseudowaves and the equivalent noise pseudowave sources, and the sub-vectors with lower indexes “e” correspond to the single-ended noise pseudowaves and the equivalent noise pseudowave sources at ports of the network element.

Considering the whole network composed of m elements (multiports), we can write a set of linear equations in matrix form

$$\mathbf{b}^o = \mathbf{S}^o \mathbf{a}^o + \mathbf{c}^o \quad (4)$$

where

$$\mathbf{a}^o = \begin{bmatrix} \mathbf{a}^{o(1)} \\ \mathbf{a}^{o(2)} \\ \vdots \\ \mathbf{a}^{o(k)} \\ \vdots \\ \mathbf{a}^{o(m)} \end{bmatrix} \quad \mathbf{b}^o = \begin{bmatrix} \mathbf{b}^{o(1)} \\ \mathbf{b}^{o(2)} \\ \vdots \\ \mathbf{b}^{o(k)} \\ \vdots \\ \mathbf{b}^{o(m)} \end{bmatrix} \quad \mathbf{c}^o = \begin{bmatrix} \mathbf{c}^{o(1)} \\ \mathbf{c}^{o(2)} \\ \vdots \\ \mathbf{c}^{o(k)} \\ \vdots \\ \mathbf{c}^{o(m)} \end{bmatrix} \quad (5)$$

and

$$\mathbf{S}^o = \begin{bmatrix} \mathbf{S}^{o(1)} & \mathbf{0} & \dots & \mathbf{0} & \dots & \mathbf{0} \\ \mathbf{0} & \mathbf{S}^{o(2)} & \dots & \dots & \dots & \mathbf{0} \\ \vdots & \vdots & \dots & \vdots & \dots & \vdots \\ \mathbf{0} & \vdots & \dots & \mathbf{S}^{o(k)} & \dots & \mathbf{0} \\ \vdots & \vdots & \dots & \vdots & \dots & \vdots \\ \mathbf{0} & \dots & \dots & \mathbf{0} & \dots & \mathbf{S}^{o(m)} \end{bmatrix} \quad (6)$$

is the block diagonal matrix in which $\mathbf{S}^{o(k)}$ is the generalized mixed-mode scattering matrix of the k th element, $\mathbf{a}^{o(k)}$ and $\mathbf{b}^{o(k)}$ are vectors of the incident and reflected noise pseudowaves at ports of the k th element, and $\mathbf{c}^{o(k)}$ is the vector of the equivalent noise pseudowave sources representing noise generated in k th network element.

Taking into account the connections between the m elements of the network, it is necessary to introduce constraints on vectors \mathbf{a}^o and \mathbf{b}^o in the form of matrix equation

$$\mathbf{b}^o = \mathbf{K}^o \mathbf{a}^o \quad (7)$$

where \mathbf{K}^o is the connection matrix of the network. Because ports i and j are connected together, incident and reflected noise pseudowaves at these ports must satisfy following relation [8]

$$\begin{bmatrix} b_i \\ b_j \end{bmatrix} = \frac{1}{Z_i + Z_j} \begin{bmatrix} Z_j - Z_i^* & 2\sqrt{\text{Re}(Z_i)\text{Re}(Z_j)} \\ 2\sqrt{\text{Re}(Z_i)\text{Re}(Z_j)} & Z_i - Z_j^* \end{bmatrix} \begin{bmatrix} a_i \\ a_j \end{bmatrix} \quad (8)$$

where Z_i and Z_j are the reference impedances of the connected ports. The above relation defines elements of the connection matrix \mathbf{K}^o corresponding to a pair of connected ports.

In practical configurations reference impedances in pairs of connected ports are real and the same. In such cases the connection matrix \mathbf{K}^o is a permutation matrix. It is a binary matrix that has exactly one entry 1 in each row and each

column and 0s elsewhere. In matrix $\overset{\circ}{\mathbf{K}}$ entries 1 occupy locations with coordinates equal to pairs of port numbers of connected ports of the network.

Substituting (7) into (4), we obtain

$$\overset{\circ}{\mathbf{W}}\overset{\circ}{\mathbf{a}} = \overset{\circ}{\mathbf{c}} \quad (9)$$

where the coefficient matrix

$$\overset{\circ}{\mathbf{W}} = \overset{\circ}{\mathbf{K}} - \overset{\circ}{\mathbf{S}} \quad (10)$$

is the generalized mixed-mode connection scattering matrix of the network. The right-hand side vector $\overset{\circ}{\mathbf{c}}$ is the vector of the equivalent noise wave sources located in each port of the network. The solution of the matrix equation (9) is the vector of ingoing noise pseudowaves at all ports of the analyzed network

$$\overset{\circ}{\mathbf{a}} = \overset{\circ}{\mathbf{W}}^{-1} \overset{\circ}{\mathbf{c}} \quad (11)$$

Using (11), we are able now to compute the correlation matrix of the incident noise pseudowaves at all network ports

$$\overset{\circ}{\mathbf{N}} = \overset{\circ}{\mathbf{a}}\overset{\circ}{\mathbf{a}}^+ = \overset{\circ}{\mathbf{W}}^{-1} \overset{\circ}{\mathbf{c}}\overset{\circ}{\mathbf{c}}^+ \overset{\circ}{\mathbf{W}}^{-1+} = \overset{\circ}{\mathbf{W}}^{-1} \overset{\circ}{\mathbf{C}} \overset{\circ}{\mathbf{W}}^{-1+} \quad (12)$$

where “+” indicates the conjugate transpose.

In (12)

$$\overset{\circ}{\mathbf{C}} = \overset{\circ}{\mathbf{c}}\overset{\circ}{\mathbf{c}}^+ \quad (13)$$

is the correlation matrix of the equivalent noise wave sources representing noise generated in all elements of the network with the mixed-mode ports as well as with the single-ended ports.

As the equivalent noise wave sources $\overset{\circ}{\mathbf{c}}^{(k)}$ of the k th element are uncorrelated with those of any other network element, the correlation matrix $\overset{\circ}{\mathbf{C}}$ is a block diagonal matrix of the form [7,8]

$$\overset{\circ}{\mathbf{C}} = \overline{\overset{\circ}{\mathbf{c}}\overset{\circ}{\mathbf{c}}^+} = \begin{bmatrix} \overset{\circ}{\mathbf{C}}_S^{(1)} & \mathbf{0} & \dots & \mathbf{0} & \dots & \mathbf{0} \\ \mathbf{0} & \overset{\circ}{\mathbf{C}}_S^{(2)} & \dots & \dots & \dots & \vdots \\ \vdots & \dots & \dots & \dots & \dots & \vdots \\ \mathbf{0} & \dots & \dots & \overset{\circ}{\mathbf{C}}_S^{(k)} & \dots & \mathbf{0} \\ \vdots & \dots & \dots & \dots & \dots & \vdots \\ \mathbf{0} & \dots & \dots & \mathbf{0} & \dots & \overset{\circ}{\mathbf{C}}_S^{(m)} \end{bmatrix} \quad (14)$$

in which $\overset{\circ}{\mathbf{C}}_S^{(1)}$, $\overset{\circ}{\mathbf{C}}_S^{(2)}$, ..., $\overset{\circ}{\mathbf{C}}_S^{(m)}$ are the generalized correlation matrices of the equivalent noise pseudowave sources of

individual network elements, while the $\mathbf{0}$ s represent null matrices. Each matrix $\overset{\circ}{\mathbf{C}}_S^{(k)}$ has the form

$$\overset{\circ}{\mathbf{C}}_S^{(k)} = \overline{\begin{bmatrix} \overset{\circ}{\mathbf{c}}_d^{(k)} \\ \overset{\circ}{\mathbf{c}}_c^{(k)} \\ \overset{\circ}{\mathbf{c}}_e^{(k)} \end{bmatrix} \begin{bmatrix} \overset{\circ}{\mathbf{c}}_d^{(k)} \\ \overset{\circ}{\mathbf{c}}_c^{(k)} \\ \overset{\circ}{\mathbf{c}}_e^{(k)} \end{bmatrix}^+} = \begin{bmatrix} \overset{\circ}{\mathbf{C}}_{dd}^{(k)} & \overset{\circ}{\mathbf{C}}_{dc}^{(k)} & \overset{\circ}{\mathbf{C}}_{de}^{(k)} \\ \overset{\circ}{\mathbf{C}}_{cd}^{(k)} & \overset{\circ}{\mathbf{C}}_{cc}^{(k)} & \overset{\circ}{\mathbf{C}}_{ce}^{(k)} \\ \overset{\circ}{\mathbf{C}}_{ed}^{(k)} & \overset{\circ}{\mathbf{C}}_{ec}^{(k)} & \overset{\circ}{\mathbf{C}}_{ee}^{(k)} \end{bmatrix} \quad (15)$$

where the “d”, “c” and “e” subscripts of sub-vectors and sub-matrices in (15) correspond, respectively, to the differential-, common- and single-ended mode equivalent noise pseudowave sources.

The generalized noise wave correlation matrix $\overset{\circ}{\mathbf{C}}$, given by (14), supplemented by the generalized connection scattering matrix $\overset{\circ}{\mathbf{W}}$, given by (10), contain full information on the noise and signal parameters of the network.

A diagonal element of the noise correlation matrix $\overset{\circ}{\mathbf{N}}$, given by (12), represents the power spectral density of the noise pseudowave entering a port of the network

$$\overset{\circ}{N}_{ii} = \overline{|a_i|^2} \quad (16)$$

while the off-diagonal elements of the matrix $\overset{\circ}{\mathbf{N}}$

$$\overset{\circ}{N}_{ij} = \overline{a_i a_j^*} \quad (17)$$

are the correlations between the input noise represented by the noise pseudowaves entering different ports of the network.

III. DIFFERENTIAL NOISE FIGURE OF MIXED-MODE MULTI-ELEMENT MULTI-PORT NETWORKS

If l is the number of the differential load in the analyzed network, then the power spectral density of differential noise entering the load port is

$$P_N = \overset{\circ}{N}_{ll} \quad (18)$$

where $\overset{\circ}{N}_{ll}$ is the l -th diagonal element of the noise matrix $\overset{\circ}{\mathbf{N}}$.

The evaluation of $\overset{\circ}{N}_{ll}$ can be derived easily from (12). In fact, if only the l -th diagonal element of the noise correlation matrix $\overset{\circ}{\mathbf{N}}$ is to be determined, by letting δ_l to be a vector whose elements are all zeros except a 1 in position l , that is

- [9] J. Randa, "Noise Characterization of Multiport Amplifiers", *IEEE Trans. Microwave Theory Tech.*, Vol. 49, No. 10, October 2001, pp. 1757-1763.
- [10] H. A. Haus, R. Adler, "Circuit Theory of Linear Noisy Networks", New York, Wiley, 1959, Ch. 5.4.
- [11] H. Bosna, "On the Theory of Linear Noisy Systems", PhD Dissertation, Dept. Elect. Eng., Eindhoven University of Technology, Eindhoven, The Netherlands, 1968.
- [12] M. Roberts, R. Wunderlich, S. Heinen, "Differential Noise Figure Measurement: A Matrix Based Approach", Proc. MTT-S, International Microwave Symposium, 2010, pp. 385-388.
- [13] J. Lintignat, S. Darfeuille, Z. Sassi, B. Barelaud, L. Billonnet, B. Jarry, "Original Approach for Extracting the Exact Noise Factor of Differential Microwave Circuits Using Mixed-Mode and Noise Wave Formalisms", Proc. 36th European Microwave Conference, September 2006, Manchester UK, pp. 518-521.
- [14] L. Moura, P. Monteiro, I. Darwazeh, "Generalized Noise Analysis Technique for Four-Port Linear Networks", *IEEE Trans. Circuits and Systems-I*, Vol. 52, No. 3, March 2005, pp. 631-640.
- [15] M. Robens, R. Wunderlich, S. Heinen, "Differential Noise Figure De-Embedding: A Comparison of Available Approaches", *IEEE Trans. Microwave Theory Tech.*, Vol. 59, No. 5, May 2011, pp. 1397-1407.
- [16] J.A. Dobrowolski, "Noise Analysis of Differential Multiport Networks", *Int. Journal of Electronics and Telecommunications*, vol. 60, No. 4, Dec. 2014, pp. 281-286.