

Integrated Analytical and Measurement System for the Evaluation of the Properties of Cast Metals and Alloys

S. Biernat ^{a,*}, A.W. Bydalek ^b

^a State Higher Vocational School In Głogów, ul. Piotra Skargi 5, 67-200 Głogów, Poland

^b University of Zielona Góra, Faculty of Mechanical Engineering, ul. Podgórna 50, 65-246 Zielona Góra, Poland

* Corresponding author. E-mail: szymon_soft@wp.pl

Received 28.02.2018; accepted in revised form 23.07.2018

Abstract

The article presents an integrated analytical and measurement system for evaluation of the properties of cast metals and alloys. The presented platform is an extension of the SLAG - PROP application with new modules, which allow to use information on metallurgical processes in an even more effective way, as well as to evaluate the finished product. In addition, the construction of a measuring station for the analysis of thermal processes taking place in a metal bath allows for precise observation of phenomena together with their appropriate interpretation. The article presents not only the cooling curves of certain copper alloys. The analysis also covered mechanical properties related to hardness, finished products depending on the mold in which the products were cast. In the literature one can find information about the mechanical properties of products in the improved state, usually after plastic or thermal treatment, omitting their properties obtained as a result of a naturally made casting. The article also presents the method of placing information in the database using a convenient graphical tool.

Keywords: Application of Information Technology to the Foundry Industry, Solidification Process, Brass, Hardness

1. Introduction

The 21st century is a period of highly developed technologies in which automation, robotics and computerization are applied in almost any industry [1 - 5]. New technologies aim to produce products with better quality, in a shorter time, the cheapest costs with the least possible negative impact on the environment [6 - 10]. In every modern industrial plant, both a large steelworks and a small foundry, there are a number of devices and machines to achieve those goals. One of the basic elements of advanced manufacturing technologies is today the implementation of an appropriate system that allows the measurement and collection of relevant data, their analysis, and on the basis of developed indicators and algorithms, automatic or semi-automatic control of manufacturing processes [11 - 14]. One should pay attention to

two integrated areas. One of them is a typically hardware area containing a set of sensors, detectors and probes that collect information and transmit it to the second area, which is the appropriate programming platform able to determine the most appropriate directions.

This study presents an integrated analytical and measurement system for assessing melting conditions for metals and alloys. It consists of two separate parts - hardware and software, which interact in close correlation and exchange data, allowing for taking specific actions to improve production and environmental indicators.

2. Analysis of the issue

The programming part contains a powerful IT platform with broad capabilities that is included in the development package "SLAG - PROP". As previously described [15, 16], the package allows the implementation of a wide range of research, experience and analysis based on data collected from world literature and own research. These include among others determination of physical, chemical and refining properties of metallurgical slags along with searching for mixtures with the best technological indicators. Moreover, determination of selected physical properties of slags - for example viscosity using the lida model. In platform is large database for determining process parameters and final alloys, in this case brass. Furthermore here is inventory of substances chemicals used in the metallurgical industry and in research laboratories that may have an adverse effect on the external environment and living organisms, together with an indication of the type of hazard, precautions and even the proper handling of materials considered to particularly dangerous. Particularly noteworthy, also related to environmental protection, is the issue of recycling materials and setting up the load charge of material with the use of secondary raw materials for obtaining products with a strictly defined composition.

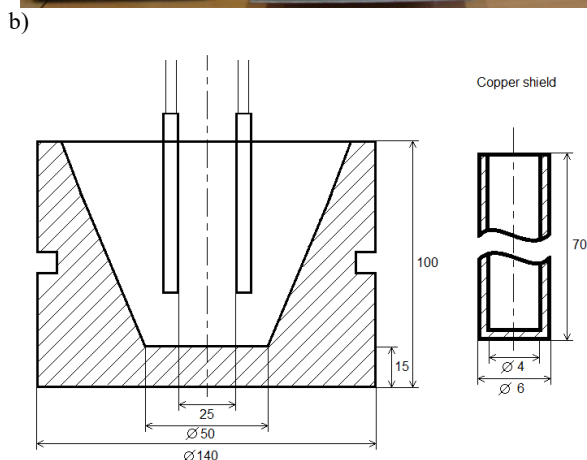
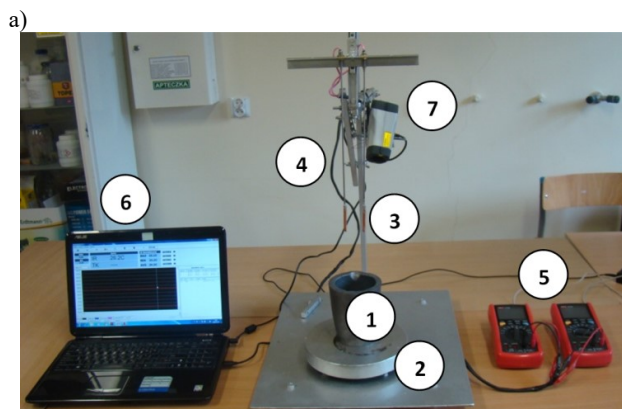

Fig. 1. a) The photo of a laboratory stand for assessing the properties of alloys and slags, b) technical drawing of crucible and copper shield

The second element that is part of the integrated system is the hardware part. It is related to the laboratory stand to assess the properties of alloys and slags presented in previous works [17]. With its help, it is possible first of all to analyze the crystallization processes occurring in certain metallurgical baths as well as observe processes occurring on the surface of systems where it comes into contact with the melting atmosphere, often of an oxidizing nature leading to the formation of metal oxides and non-metals depending on the composition of the charge.

The research device was built on the basis of a concept whose scheme was presented in [17]. The measuring system is shown in Fig. 1a. Crucible No. 1 was made of structural steel S235 by machining. In this crucible, the melt charge is placed. Next this crucible with charge is placed in a electric resistance-type furnace with a maximum operating temperature of 1300⁰ C. Thanks to the use of this type of crucible it can melt copper alloys and other colored metals many times, which after being solidified, thanks to appropriate construction, can be easily removed from it. The crucible thanks to thick walls and heating in the furnace allows to keep the temperature of the batch for a long time. Collecting the results of the experiment can take place in a longer time and therefore be more precise. The materials placed in it can't start the solidification process before placing it on the measuring stand. In addition to the crucible, it is also possible to pour the previously melted batch, but before filling it is recommended to preheat it in order to protect the batch from its too fast solidification. The crucible is placed in a laboratory stand on a special washer No. 2 made of steel, in order to separate it from the ground on which the station was placed. By means of a special construction of the crucible stand, temperature probes No. 3 K type thermocouples (NiCr - NiAl alloy) are lowered. In order to avoid rapid destruction of thermocouples, fresh covers made of 6 mm thick copper tube are applied to the thermocouples. Covers are clamped on one side. The wall thickness of these tubes are 1 mm. Additionally, in order to improve the heat transfer between the thermocouple covers, a thermoconductive paste is inserted into each copper jacket. The thermocouples with compensation wires No. 4 are connected to the electronic meters No. 5. Each of the multimeters to eliminate possible measurement errors measures both the temperature inside the bath and the voltage drop induced at the ends of the wires in accordance with the phenomenon of Seebeck. The use of two thermocouples connected to multimeters is designed to eliminate erroneous and accidental readings. Errors can result from incorrect reading of the probe itself or incorrect operation of the multimeter. If the readings are compatible, then you can assume that the results are correct. It should be noted that one of the meters is set to the temperature reading and the other to the voltage reading. Thanks to the appropriate RS235 interface, electronic meters are connected to computer No. 6, which registers all data read by the devices at an average speed of 1 measurement per second. The read data can be saved in an Excel spreadsheet and processed further.

In addition, figure 1b (Fig. 1b) presents a technical drawing of the crucibles used for conducting analyzes together with a drawing of a copper shield put on the temperature probe. The crucible has a capacity of about 470 ml. This is enough to record the temperature of changes occurring during the cooling of the melt.

Noteworthy is the fact of placing above the crucible with the test sample of pyrometer No. 7, which analyzes the temperature of oxidation processes occurring on the surface of the molten charge. It is also connected to the computer using the popular USB interface, where, using the appropriate software, it records data at exactly the same time as the electronic multimeter probes immersed in the liquid charge.

In order to perform tests on metal alloys, it becomes necessary to use a tool that makes it easier to calculate the charge of load necessary to obtain the alloy with the desired composition. The original program and method was presented at the [18]. With its help, it is possible by means of appropriate formulas to determine the composition of the charge for alloys with an assumed amount of one, two or three elements in the system, with any number of input materials. The problem can be solved in both an algebraic and a descriptive manner, which has been thoroughly tested on the example of brass.

3. Results of tests

Before performing the measurements, it was necessary to scale the device in order to eliminate measurement errors. In this

case, the measurement errors result from the separation of the element measuring thermocouples from the liquid metal by triple layer, which consists of a thermocouple steel shell, a 6 mm copper cover and a thermally conductive paste between the steel sheath and the copper cover. A number of test measurements of various metals were made to perform the device scaling. After scaling, it was possible to the research.

Two types of popular copper alloys - MO59 and M95 brass - have been selected for testing. To create the starting alloy, materials were used that were in the laboratory. Composition of those materials is presented in the Table 1.

To create the MO59 alloy it was decided to use M62 brass, zinc sheet and lead scrap. On the basis of simple calculations, it was determined that up to 1 kg of M62 brass should be added 40 g of zinc in the form of zinc-amortization sheet, followed by 21.22 g of Pb lead to obtain MO59 cast brass. M95 brass was the second selected alloy. On the basis of subsequent calculations, we obtain information that to 1 kg of copper miller should be added 160 g of brass M63 to obtain a 5% zinc alloy in its structure.

Table 1.
Elemental composition of the materials used

	Millber copper	Brass M62	Brass M63	Zinc sheet	Lead scrap
Al		0,001	0,001	0,058	0,001
As	0,0005	0,002	0,001		0,002
Bi	0,0005	0,002	0,001		0,02
Cd				0,023	0,001
Cu	99,99	61,91	63,51	0,103	0,027
Fe	0,0006	0,004	0,002	0,003	0,006
Ni	0,0005	0,005	0,001	0,003	0,001
P	0,001	0,003	0,005		0,0002
Pb	0,0005	0,219	0,004	0,69	99,44
S	0,001				0,022
Sb	0,001	0,002	0,002	0,002	0,456
Sn	0,0005	0,065	0,002	0,298	0,002
Te		0,001	0,001		0,002
Zn	0,001	37,76	36,46	98,69	0,002
Mn		0,016	0,002	0,001	
Mg				0,001	
Ti				0,119	
Cr				0,003	
Si		0,001	0,001		

In figures 2 and 3 the cooling curves of copper alloys, made for MO59 and M95 brass, have been presented. On the basis of the analysis of the obtained curves as well as the implementation of the differential over time, the melting point of alloys can be easily read for graphs. In the case of MO59 brass it is 898 °C. It should be noted that the determined value refers to the liquidus

temperature, which according to data from physical tables is 895 °C. Data from physical tables also describe the solidus temperature, which for the MO59 alloy is 880 °C, meanwhile according to the data carried out in [19, 20] it amounted to 874 °C.

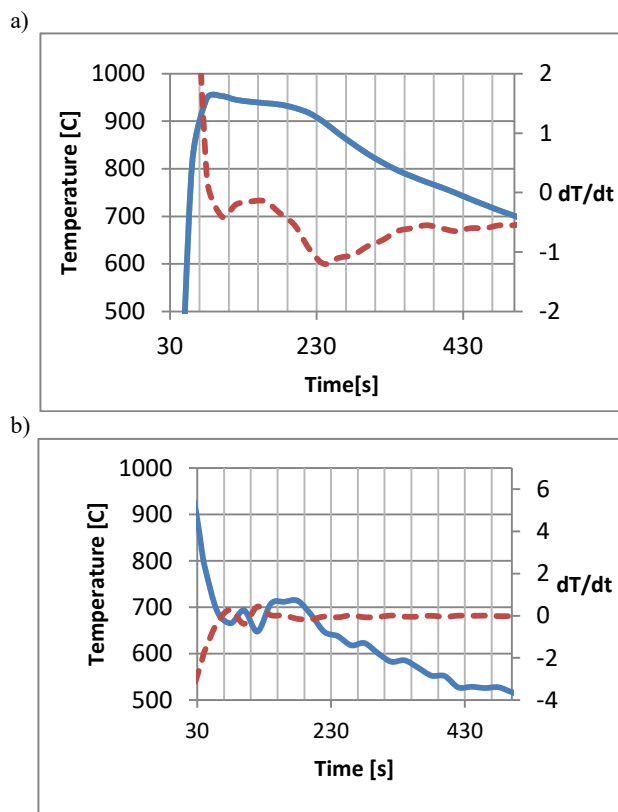

Fig. 2. MO59 brass cooling curves a) temperature course [$^{\circ}\text{C}$] over time, b) cooling curve of the liquid alloy free surface - pyrometer measurement (dotted line)

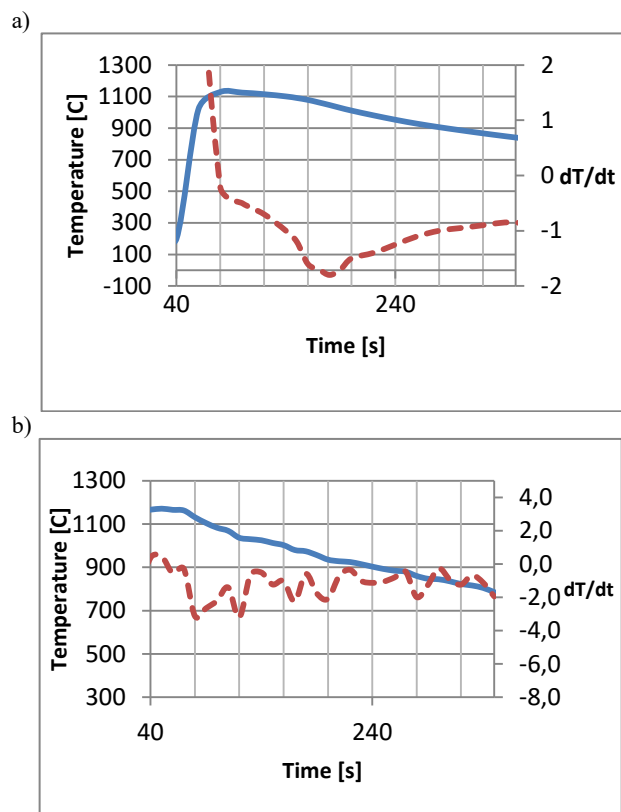

Fig. 3. M95 brass cooling curves a) temperature course [$^{\circ}\text{C}$] over time, b) cooling curve of the liquid alloy free surface - pyrometer measurement (dotted line)

A similar analysis was carried out for M95 brass. In this case, the solidus melting temperature was 1046°C , and the liquidus temperature was 1063°C . When checking the tabular data, you can also find information about the solidus and liquidus temperature, which is 1050 and 1065°C respectively [19, 20]. It is also worth paying attention to the curves determined by the pyrometer, which recorded the temperature of processes occurring on the surface of liquid alloys. These curves are presented in subsections b) of figures 2 and 2.2. As can be seen during the cooling of the alloy, oxides form on the free surface of the liquid metal as a result of contact with the atmosphere. As can be seen during the cooling of the alloy, oxides form on the surface of the liquid metal as a result of contact with the external atmosphere (Fig. 2.1.b). This leads to an increase in surface temperature, which for a certain time increases (from approximately 140th to 180th seconds of solidification) by more than 65 degrees, despite continuous, slow cooling of the alloy. It should also be noted that the pyrometer is adapted to measure liquid metals and alloys. It has the adjustment of emissivity - the ability to reflect the infrared signal through a given material. Thanks to this, a more precise measurement can be made.

In addition to the presented tests, which were made during solidification, the authors also performed the hardness testing of cast alloys. In the literature you can find a broad description of mechanical properties such as hardness or tensile strength of

different types of brass, but they concern materials that have been somehow improved or subjected to plastic working. However, there is no information on the hardness of the alloys obtained immediately after casting, taking into account the conditions of casting the material, as well as the hardness of the alloy as a function of the distance from the casting wall. The discussed alloys have been cast into two of the most popular mold, i.e. the shell and chill molds. The castings were made in the shape of discs with a diameter of 6.7 cm and a height of 3 cm. Both the chill and shell mold could conduct heat slowly, which promoted the nucleation and growth of large grains in the alloys. The mold (made of steel) was heated to a temperature close to the melting temperature of the liquid alloy. Meanwhile the shell mold was made of gypsum. It was not heated, but the thick wall of the plaster mold made it difficult to dissipate heat. The results of hardness tests for tested alloys are presented in the Table 2.

Table 2.

Comparison of the hardness of the materials tested

Type of alloy	MO59 brass		M95 brass
Mould type	Shell mold (HRB)	Chill-molds (HRB)	Shell mold (HRB)
Study No. 1.	99	53	89
Study No. 2.	120	49	89
Study No. 3.	123	58	57
Study No. 4.	99	46	95

The hardness test was carried out on a cross-section of brass castings at a distance of 2mm from the outer edge of the cast. It is also worth noting that the brass was cut with a simple metal saw so that the temperature does not rise too much during processing. As can be seen in the table, the shell mold allowed to obtain a more hard material than the annealed chill-mold. Brass MO59 cast into the shell mold had a hardness in the range of 99 - 123 HRB. However, after casting into the chill - mold had a hardness in the range of 46 - 59 HRB. You can see a huge difference in the hardness of the material depending on the type of mold to which the material was cast. In the case of M95 brass, the casting hardness in the shell mold was lower than the MO59 brass cast in a similar mold, which could be expected due to the small amount of zinc in the alloy. The hardness of M95 brass ranged from 57 to 95 HRB.

In addition, the hardness measurement of alloys as a function of distance from the walls of the alloy was made. The distances were 2, 4, 6 and 8 mm respectively. The results are presented in the Fig 4 in the form of graphs.

On the basis of the analysis of the graphs, one can notice an increase in the hardness in the direction of moving away from the outer wall of the casting, especially for the alloy MO59 cast into the chill - mould (annealed). The shell mold dissipate the heat worse than steel one, however, it was not heated to temperatures such as the steel mold, therefore as the distance increases, the hardness value starts to decrease, however in the last measurements both the MO59 and M95 alloys increase and are higher than the minimum value. This may be the result of much worse heat dissipation at a distance of 8 mm from the outer wall of the mold after the first stage of heating the mold after flooding it with a liquid melt.

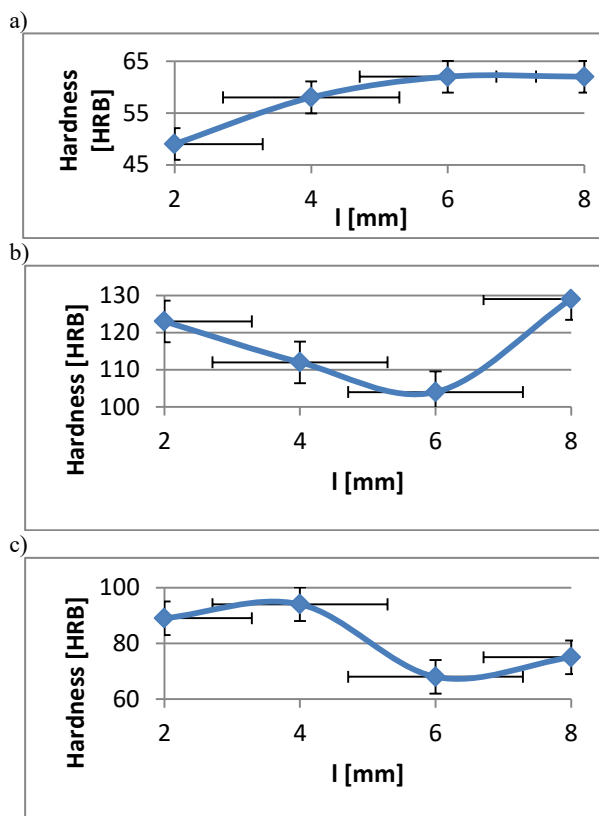

Fig. 4. a) MO59 brass – chill – mold, b) MO59 brass – shell mold, c) M95 brass – shell mold. For each graph were added the so-called error bars using a standard error

4. Summary

On the basis of the conducted research, the authors obtained information not only about the solidification characteristics of the selected alloys, but also performed hardness tests, which were not specified in any available standards, publications or catalogs. Meanwhile, the information on the mechanical properties of the products obtained, without subjecting them to additional improvement, is a key information allowing for further decisions related to the use of the product and subjecting it to possible further processing. The successful conduct of the presented research also proves the correctness of the processes carried out, as well as the concepts and ideas used. Thanks to the expansion of the metallurgical laboratory it was possible to perform process parameter research of solidification and enrich the SLAG-PROP database with new information. The wide range of applications in combination with the appropriate hardware platform for testing allows it to be used not only in industry, but also in laboratory tests. Such a set of information collected from world literature and own research becomes an invaluable tool during further research work, where a quick search of specific data is a key task that guarantees efficient exchange of information and obtaining the expected results. The ability to enter your own insights in the conducted research allows you to update the database, and at the

same time to refer to your own observations observed during the conducted experiments.

Acknowledgements

The support provided by the National Center for Research and Development under Award NoPBS3/A5/52/2015 (PBS3/244788/PP/MMB).

References

- [1] Krzeszewska, K. (2017). Information technologies in medicine. III Ogólnopolska Konferencja Interdyscyplinarna "Współczesne zastosowania informatyki", 19 May 2017 (28-33). Siedlce: Instytut Informatyki Uniwersytetu Przyrodniczo – Humanistycznego. (in Polish).
- [2] Laskowska, P.J. (2017). Information technology in agriculture, or precision agriculture. III Ogólnopolska Konferencja Interdyscyplinarna "Współczesne zastosowania informatyki", 19 May 2017 (43-48). Siedlce: Instytut Informatyki Uniwersytetu Przyrodniczo – Humanistycznego. (in Polish).
- [3] Kamiński, J. (2017). Not Just Gadgets: How Much Computer Science Is in Cars. III Ogólnopolska Konferencja Interdyscyplinarna "Współczesne zastosowania informatyki", 19 May 2017 (94- 96). Siedlce: Instytut Informatyki Uniwersytetu Przyrodniczo – Humanistycznego. (in Polish).
- [4] Pieprzyca, J., Warzecha, P., Merder, T. & Warzecha, M. (2016), Experimental Methods of Validation for Numerical Simulation Results on Steel Flow through Tundish. *Archives of Metallurgy and Materials*. 61(4), 2057-2060.
- [5] Kalisz, D., Gerasin, S., Bobrowski, P., Żak, P.L. & Skowronek, T. (2016). Computer Simulation of Microsegregation of Sulphur and Manganese and Formation of MnS Inclusions While Casting Rail Steel. *Archives of Metallurgy and Materials*. 61(4), 1939-1944.
- [6] Pająk, E. (2000). *Advanced production technologies*. Politechnika Poznańska. Poznań. (in Polish).
- [7] Ruszaj, A. (1999). *Unconventional methods of making machine elements and tools*. Kraków: Instytut Obróbki Skrawaniem. (in Polish).
- [8] Dudek, P. & Rapacz-Kmita, A. (2016). Rapid Prototyping, Technologies, Materials and Advances. *Archives of Metallurgy and Materials*. 61(2A), 891-896.
- [9] Drozd, E., Jelonek, M., Wyrwa, J. & Rekas, M. (2015). The Influence of the Way of Alumina Addition on Properties Improvement of 3YSZ Material. *Archives of Metallurgy and Materials*. 60(2A), 999-1002.
- [10] Topolska, S. & Łabanowski, J. (2017). Environmental Degradation of Dissimilar Austenitic 316L And Duplex 2205 Stainless Steels Welded Joints. *Archives of Metallurgy and Materials*. 62(4), 2107-2112.
- [11] Głowacz, Z. (2011). Automatic Recognition of Armature Current of DC Motor with Application of FFT and GSDM. *Archives of Metallurgy and Materials*. 56(1), 25-30.
- [12] Stańczyk, M. & Figlus, T. (2016). A method for the selection of certain force and energy parameters of automatic sheet metal coiling machines. *Metallurgija*. 55(1), 79-82.
- [13] Śliwa, A., Kwaśny, W., Sroka, M. & Dziwis, R. (2017). Computer simulation of the aluminium extrusion process. *Metallurgija*. 56,(3-4), 422-424.
- [14] Kukla, S. (2017). Improving Quality and Occupational Safety on Automated Casting Lines. *Archives of Foundry Engineering*. 17(3), 69-72.
- [15] Biernat, S. & Bydałek, A.W. (2014). Optimization of the Brass Melting. *Archives of Foundry Engineering*. 14(3), 5-10.
- [16] Biernat, S., Bydałek, A.W. & Schlafka, P. (2012). Analysis of the possibility of estimation ecological slag propriety with use the DATABASE. *Metallurgija*. 51,(1), 59-62.
- [17] Biernat, S., Bydałek, A., Wołczyński, W. & Holtzer, M. (2017). Method and Apparatus for Assessing the Properties of Slags. *Archives of Foundry Engineering*. 16(3), 13-18.
- [18] Biernat, S., Bydałek, A.W., Wołczyński, W. & Najman, K. (2017), Analysis of the possibility of calculating the charges on the example of brasses. *Archives of Metallurgy and Materials*. 62(4), 2165-2170.
- [19] MatWeb. (2011). *Material Property Data*. Retrieved February 2018, from <http://www.matweb.com/index.aspx>.
- [20] Euralliage. (2018). *The specialist in storage, trading and cutting of non-ferrous metals*. Retrieved February 2018, from http://www.euralliage.com/index_english.htm.