

The combined geodetic network adjusted on the reference ellipsoid – a comparison of three functional models for GNSS observations

Roman Kadaj

Rzeszów University of Technology
Department of Geodesy and Geotechnics
12 Al. Powstańców Warszawy, 35-959 Rzeszów, Poland
e-mail: geonet@geonet.net.pl

Received: 4 April 2016 / Accepted: 08 August 2016

Abstract: The adjustment problem of the so-called combined (hybrid, integrated) network created with GNSS vectors and terrestrial observations has been the subject of many theoretical and applied works. The network adjustment in various mathematical spaces was considered: in the Cartesian geocentric system on a reference ellipsoid and on a mapping plane. For practical reasons, it often takes a geodetic coordinate system associated with the reference ellipsoid. In this case, the Cartesian GNSS vectors are converted, for example, into geodesic parameters (azimuth and length) on the ellipsoid, but the simple form of converted pseudo-observations are the direct differences of the geodetic coordinates. Unfortunately, such an approach may be essentially distorted by a systematic error resulting from the position error of the GNSS vector, before its projection on the ellipsoid surface. In this paper, an analysis of the impact of this error on the determined measures of geometric ellipsoid elements, including the differences of geodetic coordinates or geodesic parameters is presented. Assuming that the adjustment of a combined network on the ellipsoid shows that the optimal functional approach in relation to the satellite observation, is to create the observational equations directly for the original GNSS Cartesian vector components, writing them directly as a function of the geodetic coordinates (in numerical applications, we use the linearized forms of observational equations with explicitly specified coefficients). While retaining the original character of the Cartesian vector, one avoids any systematic errors that may occur in the conversion of the original GNSS vectors to ellipsoid elements, for example the vector of the geodesic parameters. The problem is theoretically developed and numerically tested. An example of the adjustment of a subnet loaded from the database of reference stations of the ASG-EUPOS system was considered for the preferred functional model of the GNSS observations.

Key words: combined geodetic network, hybrid geodetic network, GNSS vectors on the ellipsoid, network adjustment on the ellipsoid

1. Introduction

The combined (hybrid, integrated) geodetic network, composed of satellite and terrestrial observations, has been the object of study since the 70's (e.g. Krakiwsky and Thomson, 1974; Thomson 1976; Groten, 1977; Gajderowicz, 1979; 1981; Adam et al., 1982; Welsch and Oswald, 1984; Baeumker, 1984; Świątek, 1986, 1988), when, Doppler observations were used for satellite positioning. A characteristic element in the calculation of such networks was an estimation of the 3D transformation parameters between two coordinate systems – satellite and terrestrial. Currently, the relationship between the applied systems, satellite and terrestrial are known a priori and can be used to transform or reduce the GNSS vectors ($\Delta X, \Delta Y, \Delta Z$) and terrestrial observations into one common space. The GNSS vectors may also be integrated with various terrestrial observations creating a combined (hybrid, integrated) geodetic network. Such a network can be adjusted and elaborated directly in a Cartesian geocentric system, in which the GNSS vectors are expressed. For the functional modeling of a combined network, each measured network element should be a function of the unknown coordinates (X, Y, Z) of the network points expressed (see. e.g. Hofmann-Wellenhof et al., 2008).

An alternatively functional modeling of the combined network consists of the conversion of the Cartesian GNSS vector ($\Delta X, \Delta Y, \Delta Z$) and another observation to some geometric elements in an ellipsoidal geocentric system (B, L, h). The converted observations are conventionally referred to pseudo-observations. An example of such pseudo-observations, converted from the Cartesian GNSS vector, are the components of the vector ($s, \alpha, \Delta h$), where s, α – length and azimuth of the geodesic and Δh as the difference of ellipsoidal heights. A similar modeling, but in terms of 2D+1D (the independent adjustment of two-dimensional and heights network), was implemented in the adjustment program GeoNet (www.geonet.net.pl). The program has been used for the elaboration of national geodetic networks in Poland since 1997 (Kadaj, 1997, 1998 – Section 3.6.5). The azimuth and length of the geodesic are the pseudo-observations in the network, which can be integrated with terrestrial (classic) measurements of lengths, angles or directions. The ellipsoidal heights difference is a pseudo-observation of the satellite leveling network. The conversion of Cartesian vectors is parallel to the conversion of the corresponding covariance sub-matrices between two spaces. Even long before the satellite navigation era, Molodensky (1954) proposed the network adjustment on the ellipsoid by the use of chords, connecting points on the ellipsoid. As Czarnecki (1994) quotes, Molodensky's theory introduces new notions in geodesy, like, for example, the azimuth of the chord.

Another and the simplest kind of pseudo-observations on the ellipsoid, as converted GNSS vectors, are the differences of geodetic coordinates ($\Delta B, \Delta L, \Delta h$). These pseudo-observations have been used in the integration of Doppler satellite observations and terrestrial networks (cf. e.g. Thomson, 1976). The conversion of Cartesian vectors directly to the coordinates differences on the mapping plane is also used in the tasks of adjustment of the combined geodetic networks, that is vectors

$(\Delta x, \Delta y)$ and, separately, ellipsoidal height differences, in turn, used to transform the normal height; cf. Gajderowicz (1997) and also Gargula (2010). It should be emphasized, that Gajderowicz’s concept originates the computer implementation and application to the combined network adjustment in the Polish cartographic system “1965”. A more universal approach, independent of the mapping system and numerical errors of the mapping, is the combined network adjustment on an geocentric ellipsoid. For this purpose, Cartesian GNSS vectors are transformed into vectors of geodetic coordinate differences. Of course, the conversion to any of the mapping system is always possible through the proper conversion of finally adjusted geodetic coordinates.

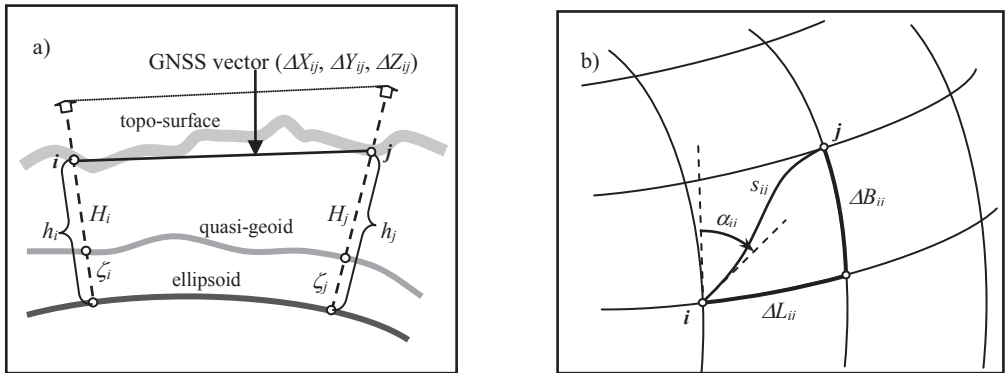

Fig. 1. a) The GNSS Cartesian vector after antenna reductions in the vertical plane with height elements. b) Geodesic parameters (distance and azimuth) or differences of geodetic coordinates as results of the projection of the GNSS Cartesian vector on the ellipsoid surface

However, the task of the conversion of Cartesian GNSS vectors into geometric elements on the reference ellipsoid or on a mapping plane must be the subject of certain restrictions due to the risk of significant systematic errors. It is clear that any displacement of the Cartesian vector relative to the ellipsoid, includes a change, for example, in the length of the received geodesic or other geometric elements. It is very important, therefore, possible, to determine the exact starting point (attachment point) of the GNSS vector before its projection on the ellipsoid. This, in turn, is not always possible or possible only after the network adjustment. The analysis in this area is presented in Section 2.

As we have seen, the conversion of Cartesian GNSS vectors into pseudo-observations in the ellipsoidal system can cause significant systematic errors. An alternative to this approach freed from the influence of systematic error may be to preserve the original form of the Cartesian GNSS vector and express it as a function of the geodetic coordinates (B, L, h) . The idea of such a functional model on the ellipsoid has some similarity to the concept, expressing the GNSS vector in functions of local 3D – Cartesian or cartographic coordinates (x, y) and transformation parameters between two systems (see: Strauss and Walter, 1993; Daxinger and Stirling, 1995; Strehle, 1996). For this purpose, the authors propose a numerical method for

calculating the required partial derivatives occurring in the linearized equations of observations. Assuming now, that the target system is the ellipsoidal system with geodetic coordinates (B, L, h) , we set simple formulas for the coefficients of linear differential equations where the unknowns are the corrections to the approximate coordinates (see Section 3). In the functional model, we apply additional modification aimed at replacing the angular corrections (dB, dL) by the lengths of the small arcs of a meridian and a parallel (db, dl) . In this way the vector of unknowns becomes homogeneous with respect to measure units, which has positive significance associated with the conditioning of numerical tasks.

The adjustment of the combined network is a nonlinear least squares task usually solved by means of the iterative Gauss-Newton algorithm (e.g. Deutsch, 1965). The practical result of this publication is a modification of programs in the GeoNet system, that was used to perform numerical tests on the topic of this publication (test results with comments given in Section 6).

2. Ellipsoidal elements $(\Delta B, \Delta L, \Delta h)$ or $(s, \alpha, \Delta h)$ as pseudo-observations

The vector $\Delta \mathbf{R}_{ij} = (\Delta X_{ij}, \Delta Y_{ij}, \Delta Z_{ij})$ as a GNSS observation between certain points i, j of a geodetic network in Cartesian geocentric system can be converted into a corresponding vector of differences of geodetic coordinates $\Delta \mathbf{E}_{ij} = (\Delta B_{ij}, \Delta L_{ij}, \Delta h_{ij})$ or the vector composed of geodesic parameters and the ellipsoidal height difference $\mathbf{G}_{ij} = (s_{ij}, \alpha_{ij}, \Delta h_{ij})$ providing that the approximate coordinates of the attachment point (X_i, Y_i, Z_i) of the vector are known (we assume, that is the point with index i). Let $\Delta \mathbf{R} = (\Delta x, \Delta y, \Delta z)$ denote an error of a near position of the attachment point of the GNSS vector. The natural question is: what is the impact on the determined elements in the ellipsoid frame having the error $\Delta \mathbf{R}$. Of course, any translation (shift) of the vector $\Delta \mathbf{R}$ does not change its Cartesian components, but causes a change of pseudo-observations created in the ellipsoidal system (differences of geodetic coordinates or geodesic parameters).

2.1. The conversion algorithm $\Delta \mathbf{R} \Rightarrow (\Delta B, \Delta L, \Delta h)$ or $\Delta \mathbf{R} \Rightarrow (s, \alpha, \Delta h)$

The conversion algorithm comprises the following operations:

Step 1. We assume the approximate coordinates of the begin point $\mathbf{R}_i = (X_i, Y_i, Z_i)$ of the vector $\Delta \mathbf{R}_{ij} = (\Delta X_{ij}, \Delta Y_{ij}, \Delta Z_{ij})$ and calculate the corresponding coordinates of the end point of this vector,

$$\mathbf{R}_j = \mathbf{R}_i + \Delta \mathbf{R}_{ij} = (X_i + \Delta X_{ij}, Y_i + \Delta Y_{ij}, Z_i + \Delta Z_{ij}) = (X_j, Y_j, Z_j) \tag{1}$$

(in this way we determine also the vector in the ellipsoidal geocentric system)

Step 2. Using any algorithm for the transformation of geocentric Cartesian coordinates into geodetic coordinates, $(X, Y, Z) \Rightarrow (B, L, h)$, we calculate the corresponding geodetic (ellipsoidal) coordinates:

$$\begin{aligned} \mathbf{R}_i &= (X_i, Y_i, Z_i) \Rightarrow (B_i, L_i, h_i) = \mathbf{E}_i, \\ \mathbf{R}_j &= (X_i + \Delta X_{ij}, Y_i + \Delta Y_{ij}, Z_i + \Delta Z_{ij}) = (X_j, Y_j, Z_j) \Rightarrow (B_j, L_j, h_j) = \mathbf{E}_j \end{aligned} \quad (2)$$

Step 3. We calculate the defined elements in the ellipsoidal frame:

a) The vector of geodetic coordinates differences:

$$\Delta \mathbf{E}_{ij} = \mathbf{E}_j - \mathbf{E}_i = (B_j - B_i, L_j - L_i, h_j - h_i) = (\Delta B_{ij}, \Delta L_{ij}, \Delta h_{ij}) \quad (3)$$

b) The vector of geodesic parameters and the ellipsoidal heights difference:

$$(\mathbf{E}_i, \mathbf{E}_j) \Rightarrow (s_{ij}, \alpha_{ij}, \Delta h_{ij}) = \mathbf{G}_{ij} \quad (4)$$

$$s_{ij} = G_1(B_i, L_i, B_j, L_j); \alpha_{ij} = G_2(B_i, L_i, B_j, L_j); \Delta h_{ij} = h_j - h_i \text{ (as in (3))} \quad (5)$$

where G_1, G_2 are the functions defining the geodesics parameters (length and azimuth). In general, the algorithms of the functions are known in higher geodesy (e.g.: Warchałowski, 1952; Czarnecki, 1994).

The calculated pseudo-observation measures may be flawed due to a systematic error, depending on a position error of the GNSS vector in Cartesian geocentric system. A detailed analysis is presented in the next Section 2.2 of this paper.

2.2. Assessment of the impact of a position error of the GNSS vector on the geodetic coordinates differences and geodesic parameters

2.2.1. Formulating the main issues

Suppose that the attachment point \mathbf{R}_i of the GNSS vector $\Delta \mathbf{R}_{ij}$ is shifted by a vector $\Delta \mathbf{R} = (\Delta X, \Delta Y, \Delta Z)$. We want to estimate what will be on that account the resulting error (distortion) $\delta_{\Delta \mathbf{E}} = (\delta_{\Delta B}, \delta_{\Delta L}, \delta_{\Delta h})$ for the vector components $\Delta \mathbf{E}$ or an error $\delta_{\mathbf{G}} = (\delta_s, \delta_\alpha, \delta_{\Delta h})$ for the geodesic vector $\mathbf{G} = (s, \alpha, \Delta h)$. We will have in general form:

$$\begin{aligned} \delta_{\Delta \mathbf{E}} &= \Delta \mathbf{E}' - \Delta \mathbf{E} \text{ and } \delta_{\mathbf{G}} = \mathbf{G}' - \mathbf{G} \\ (\delta_{\Delta B} &= \Delta B' - \Delta B, \delta_{\Delta L} = \Delta L' - \Delta L, \delta_{\Delta h} = \Delta h' - \Delta h, \delta_s = s' - s, \delta_\alpha = \alpha' - \alpha), \end{aligned} \quad (6)$$

where the vectors $\Delta \mathbf{E}' = (\Delta B', \Delta L', \Delta h')$, $\mathbf{G}' = (s', \alpha', \Delta h')$ are calculated according to the algorithm shown in Section 2.1, for shifted (translated) points: $\mathbf{R}_i' = \mathbf{R}_i + \Delta \mathbf{R}$, $\mathbf{R}_j' = \mathbf{R}_j + \Delta \mathbf{R}$. Naturally, $\Delta \mathbf{R}_{ij}' = \mathbf{R}_j' - \mathbf{R}_i' = \mathbf{R}_j - \mathbf{R}_i = \Delta \mathbf{R}_{ij}$. An example is shown in Table 1.

Tab. 1. Numerical example: influence of an error of GNSS vector position on the differences of geodetic coordinates – posterior obtained (data for two points are taken from the ASG-EUPOS – network)

| | | | | |
|-------------------------------------------------------------------------------------------------------|------------------------------------|------------------------------------|------------------------------------|--------------------------|
| <i>Cartesian coordinates for two points (ASG-EUPOS stations) in PL-ETRF2000</i> | | | | |
| <i>ID</i> | <i>X[m]</i> | <i>Y[m]</i> | <i>Z[m]</i> | <i>Name in ASG-EUPOS</i> |
| 1 | 3486403.5385 | 1392187.3370 | 5139218.6640 | GIZY |
| 2 | 3878289.7496 | 1092566.8446 | 4928217.8516 | JLGR |
| <i>Cartesian vector</i> | | | | |
| <i>ID(i) - ID(j)</i> | <i>ΔX[m]</i> | <i>ΔY[m]</i> | <i>ΔZ[m]</i> | |
| 1-2 | 391886.2111 | -299620.4924 | -211000.8124 | |
| <i>Geodetic coordinates</i> | | | | |
| <i>ID</i> | <i>B [° ' "]</i> | <i>L [° ' "]</i> | <i>h [m]</i> | |
| 1 | 54 2 8.8055411 | 21 46 3.9623432 | 166.8254 | |
| 2 | 50 55 10.0505252 | 15 43 59.6942273 | 408.1899 | |
| <i>Vector of differences of geodetic coordinates and geodesic parameters:</i> | | | | |
| <i>ID(i) - ID(j)</i> | | | | |
| 1-2 | <i>ΔB = -11218.7550159"</i> | | <i>ΔL = -21724.2681159"</i> | |
| | | | <i>Δh = 241.3645m</i> | |
| 1-2 | <i>s = 536668.1199m</i> | | <i>α = 258.02391082 [g]</i> | |
| <i>The Cartesian coordinates after translation δ_R = (I, I, I) (components in meters)</i> | | | | |
| <i>ID'</i> | <i>X[m]</i> | <i>Y[m]</i> | <i>Z[m]</i> | |
| 1' | 3486404.5385 | 1392188.3370 | 5139219.6640 | |
| 2' | 3878290.7496 | 1092567.8446 | 4928218.8516 | |
| <i>The geodetic coordinates after translation</i> | | | | |
| <i>ID'</i> | <i>B [° ' "]</i> | <i>L [° ' "]</i> | <i>h [m]</i> | |
| 1' | 54 2 8.7905164 | 21 46 3.9929936 | 168.3980 | |
| 2' | 50 55 10.0399357 | 15 43 59.7296201 | 409.7439 | |
| <i>Vector of geodetic coordinates differences and geodesic parameters after translation</i> | | | | |
| <i>ID' (i) - ID' (j)</i> | | | | |
| 1' - 2' | <i>ΔB' = -11218.7505807"</i> | | <i>ΔL' = -21724.2633735"</i> | |
| | | | <i>Δh' = 241.3459m</i> | |
| 1' - 2' | <i>s' = 536667.9885m</i> | | <i>α' = 258.02391817 [g]</i> | |
| <i>Errors of parameters after translation</i> | | | | |
| | <i>δ_{ΔB} = +0.004435"</i> | <i>δ_{ΔL} = +0.004742"</i> | <i>δ_{Δh} = -0.0186m</i> | |
| | <i>δ_s = -0.1314m</i> | | <i>δ_α = 0.0735 [cc]</i> | |

In order to estimate the size of the propagation of position error of the GNSS vector, we will use the simplified differential formulas.

2.2.2. Distortion of pseudo-observations in the form of geodetic coordinates differences

We denote the corresponding change of the output vector as a vector

$$\delta_{AEij} = (\delta_{ABij}, \delta_{ALij}, \delta_{Ahij}) = \delta_{Ej} - \delta_{Ei}, \tag{7}$$

where $\delta_{Ei} = (\delta_{Bi}, \delta_{Li}, \delta_{hi})$, $\delta_{Ej} = (\delta_{Bj}, \delta_{Lj}, \delta_{hj})$ are the corresponding change of points coordinates. Using the matrix notation, we further assume that above defined vectors will be treated as well as column vectors. Let $R = F(E)$ is the function of

a vector expressing the relationship between the vectors \mathbf{E} and \mathbf{R} , and $\mathbf{J}(\mathbf{E}) = \partial\mathbf{F}(\mathbf{E})/\partial\mathbf{E}$ – Jacobian as (3×3) matrix of first derivatives of the function \mathbf{F} . We can express the linear relationship between errors δ_E, \mathbf{A}_R of the corresponding vectors \mathbf{E}, \mathbf{R} as follows:

$$\mathbf{A}_R \cong \mathbf{J}(\mathbf{E}) \cdot \delta_E \Rightarrow \delta_E \cong \mathbf{J}^{-1}(\mathbf{E}) \cdot \mathbf{A}_R \tag{8}$$

(the existence of the inversion is guaranteed by the reversibility of the transformation between Cartesian and geodetic coordinates). The transformation $\mathbf{F} : \mathbf{E} \Rightarrow \mathbf{R}$ is realized by the well-known formulas:

$$\begin{aligned} X &= (R_N + h) \cdot \cos(B) \cdot \cos(L) \\ Y &= (R_N + h) \cdot \cos(B) \cdot \sin(L) \\ Z &= [R_N \cdot (1 - e^2) + h] \cdot \sin(B) \end{aligned} \tag{9}$$

where

$$R_N = a / [1 - e^2 \cdot \sin^2(B)]^{1/2} \tag{10}$$

is the radius of curvature in the prime vertical, a – is the major semi-axis of ellipsoid and $e^2 = (a^2 - b^2) / a^2$ – the first eccentricities squared, h – the ellipsoidal height. The defined Jacobian matrix $\mathbf{J}(\mathbf{E})$ can be expressed as (for simplicity we omit the argument (vector) \mathbf{E}):

$$\mathbf{J} = \mathbf{U} \cdot \mathbf{C} \tag{11}$$

where

$$\mathbf{C} = \text{diag} [(R_M + h), (R_N + h) \cdot \cos(B), 1] \tag{12}$$

is a diagonal matrix, where R_M is the radius of curvature of the meridian for the latitude B ,

$$R_M = a \cdot (1 - e^2) / [1 - e^2 \cdot \sin^2(B)]^{3/2} \tag{13}$$

and

$$\mathbf{U} = \begin{bmatrix} -\sin(B) \cdot \cos(L) & -\sin(L) & \cos(B) \cdot \cos(L) \\ -\sin(B) \cdot \sin(L) & \cos(L) & \cos(B) \cdot \sin(L) \\ \cos(B) & 0 & \sin(B) \end{bmatrix} \tag{14}$$

has the property of orthonormal matrices: $\mathbf{U}^T \cdot \mathbf{U} = \mathbf{I} \Rightarrow \mathbf{U}^T = \mathbf{U}^{-1}$, \mathbf{I} is the unit matrix. The above linear formula (8) with the rotation matrix (14) was used in geodesy in many issues (see e.g. Thomson, 1976).

Let

$$\underline{\mathbf{C}} = \text{diag} [R_M, R_N \cdot \cos(B), 1]. \tag{15}$$

As a result (8) the small changes δ_E of the geodetic vector, can be converted in the vector δ_e of small arcs of the meridian and parallel δ_b, δ_l and not revised component of the height change δ_h :

$$\delta_e = [\delta_b, \delta_l, \delta_h]^T = \underline{C} \cdot \delta_E = \underline{C} \cdot \underline{J}^{-1}(\mathbf{E}) \cdot \mathbf{A}_R = \underline{C} \cdot \mathbf{C}^{-1} \cdot \mathbf{U}^T \cdot \mathbf{A}_R \approx \mathbf{U}^T \cdot \mathbf{A}_R \tag{16}$$

(note that $\underline{C} \cdot \mathbf{C}^{-1} = \text{diag} [R_M / (R_M + h), R_N / (R_N + h), 1] \approx \mathbf{I} = \text{unit matrix}$). In particular, it will

$$\delta_b = R_M \cdot \delta_B, \quad \delta_l = R_N \cdot \cos(B) \cdot \delta_L \tag{17}$$

The equations (8), (11) we use now to evaluate the impact of the position error of the GNSS vector on the differences of geodetic coordinates, assuming that end points of the vector are projected on the ellipsoid according to the Helmert's principle, in the normal direction to the ellipsoid. If the GNSS vector translates by a vector \mathbf{A}_R then projected on the ellipsoid points (with indices i, j) will receive adequate displacements (we use the matrix \mathbf{U} as the matrix function of \mathbf{E}):

$$\delta_{E_i} = \mathbf{C}_i^{-1} \cdot \mathbf{U}^T(\mathbf{E}_i) \cdot \mathbf{A}_{R_i}; \quad \delta_{E_j} = \mathbf{C}_j^{-1} \cdot \mathbf{U}^T(\mathbf{E}_i + \Delta \mathbf{E}_{ij}) \cdot \mathbf{A}_{R_j} \tag{18}$$

$$\mathbf{A}_{R_i} = \mathbf{A}_{R_j} = \mathbf{A}_R \text{ (equal shift for two points)}$$

Accordingly, the resultant impact on differences of geodetic coordinates is:

$$\begin{aligned} \delta_{\Delta E_{ij}} &= \delta_{E_j} - \delta_{E_i} = [\delta_{B_j} - \delta_{B_i}, \delta_{L_j} - \delta_{L_i}, \delta_{h_j} - \delta_{h_i}]^T \\ &= [\mathbf{C}_j^{-1} \cdot \mathbf{U}^T(\mathbf{E}_i + \Delta \mathbf{E}_{ij}) - \mathbf{C}_i^{-1} \cdot \mathbf{U}^T(\mathbf{E}_i)] \cdot \mathbf{A}_R \end{aligned} \tag{19}$$

where

$$\mathbf{U}^T(\mathbf{E}_i) = \begin{bmatrix} -\sin(B_i) \cdot \cos(L_i) & -\sin(B_i) \cdot \sin(L_i) & \cos(B_i) \\ -\sin(L_i) & \cos(L_i) & 0 \\ \cos(B_i) \cdot \cos(L_i) & \cos(B_i) \cdot \sin(L_i) & \sin(B_i) \end{bmatrix} \tag{20}$$

$$\mathbf{U}^T(\mathbf{E}_i + \Delta \mathbf{E}_{ij}) = \begin{bmatrix} -\sin(B_i + \Delta B_{ij}) \cdot \cos(L_i + \Delta L_{ij}) & -\sin(B_i + \Delta B_{ij}) \cdot \sin(L_i + \Delta L_{ij}) & \cos(B_i + \Delta B_{ij}) \\ -\sin(L_i + \Delta L_{ij}) & \cos(L_i + \Delta L_{ij}) & 0 \\ \cos(B_i + \Delta B_{ij}) \cdot \cos(L_i + \Delta L_{ij}) & \cos(B_i + \Delta B_{ij}) \cdot \sin(L_i + \Delta L_{ij}) & \sin(B_i + \Delta B_{ij}) \end{bmatrix} \tag{21}$$

Table 2 shows an example of evaluation of the error, according to the formula (19) for data identical as in the Table 1. It can be said that the results estimated in Tables

1 and 2 are practically comparable, although the differential formula used in the latter case has linearization errors.

We are looking for a more general formula to estimate the impact of the position error of the GNSS vector on the ellipsoidal elements, assuming a continued simplified model of the Earth’s surface in the form of a sphere (we assume that output forms are only used for estimating the error size with precision to within 2 – 3 significant digits).

For the analysis of the problem on the sphere we can assume any attachment point of the GNSS vector. Therefore, we set $B_i = 0, L_i = 0, h = 0$ and we get after ordering (for simplicity we omit points indices):

$$M = U^T(\Delta E) - U^T(\theta) = \begin{bmatrix} -\sin(\Delta B) \cdot \cos(\Delta L) & -\sin(\Delta B) \cdot \sin(\Delta L) & \cos(\Delta B) - 1 \\ -\sin(\Delta L) & \cos(\Delta L) - 1 & 0 \\ \cos(\Delta B) \cdot \cos(\Delta L) - 1 & \cos(\Delta B) \cdot \sin(\Delta L) & \sin(\Delta B) \end{bmatrix} \quad (22)$$

(θ – zero vector).

Tab. 2. Numerical example: the influence of a position vector error on the differences of geodetic coordinates – an alternative assessment according to the formula (19)

| The impact of the position error of Cartesian vector on the differences of geodetic coordinates | | | |
|-------------------------------------------------------------------------------------------------------------------------------------|-------|-----------------|----------------|
| Quantities | | Values | |
| B_1 | L_1 | 194528.8055411" | 78363.9623432" |
| B_2 | L_2 | 183310.0505252" | 56639.6942273" |
| $U^T(E_1)$ (matrix elements) | | -7.516704E-1 | -3.001563E-1 |
| | | -3.708454E-1 | 9.286946E-1 |
| | | 5.454037E-1 | 2.177901E-1 |
| $U^T(E_2)$ (matrix elements) | | -7.471776E-1 | -2.104901E-1 |
| | | -2.711590E-1 | 9.625346E-1 |
| | | 6.067935E-1 | 1.709420E-1 |
| R_N, R_M, h for point 1 | | 6392168.8409m | 6377345.1035m |
| R_N, R_M, h for point 2 | | 6391040.4428m | 6373968.3560m |
| Distortion of coordinate differences using the differential formula (19) after translation of the GNSS vector by the vector (1,1,1) | | | |
| $\delta_{AB} = 0.004429''$ $\delta_{AL} = 0.004766''$ $\delta_{Ah} = -0.0186m$ | | | |

In case of the sphere we can also assume any azimuth for the GNSS vector, especially in the direction of meridian or parallel. In the first case it would be $\Delta L=0$, then

$$\mathbf{M} = \begin{bmatrix} -\sin(\Delta B) & 0 & -2 \cdot \sin^2(\Delta B/2) \\ 0 & 0 & 0 \\ -2 \cdot \sin^2(\Delta B/2) & 0 & \sin(\Delta B) \end{bmatrix} \quad (23)$$

Considering the formulas (17), (18) and denoting: δ_p – corresponding to a fixed position ($B=0, L=0$) the local horizontal distortion of the spheric arc, $\delta_{\Delta h}$ – the local height distortion of the height difference, Δ_h, Δ_p – the translation components of the GNSS vector, R_s – the radius of the spherical model of the Earth and s – the length of the arc corresponding to the angle ΔB , we obtain from (23) the simplified relation:

$$\begin{bmatrix} \delta_p \\ \delta_{\Delta h} \end{bmatrix} \approx \begin{bmatrix} -s/R_s & -0.5 \cdot (s/R_s)^2 \\ -0.5 \cdot (s/R_s)^2 & s/R_s \end{bmatrix} \cdot \begin{bmatrix} \Delta_h \\ \Delta_p \end{bmatrix} \quad (24)$$

As can be seen, the maximum distortion in length of the arc or in the height difference expresses the inequality:

$$|\delta_p|, |\delta_{\Delta h}| \leq \eta \cdot [1 + (1/2) \cdot \eta^2] \cdot \Delta \approx \eta \cdot \Delta \quad (25)$$

where

$$\begin{aligned} \eta &= s/R_s \approx |\Delta B| \approx |\sin(\Delta B)| \quad (\text{only for a small arc}) \\ \Delta &= \max(|\Delta_h|, |\Delta_p|) \\ s &= \text{length of the arc section} \end{aligned}$$

A similar result can be obtained directly from the geometrical situation shown in Figure 2a, b. Figure 2a shows the impact of the vertical displacement of the GNSS vector on the error of the arc length on the sphere. It is similar to the classic length reduction due to the height. The relation (24) implies that there is also some impact of the vertical movement of the GNSS vector on the heights difference. Assuming the displacement vector $\underline{\Delta} = [\Delta_h, 0]^T$ according to (24), we obtain the components: $\delta_p = -s/R_s, \delta_{\Delta h} = -\Delta_h \cdot 0.5 \cdot (s/R_s)^2$. For example, for the vector length $s \approx 537$ km, as in Table 1, were: $\delta_p = -\Delta_h \cdot (537/6385) = -\Delta_h \cdot 0.0843$ and $\delta_{\Delta h} = -\Delta_h \cdot 0.5 \cdot 0.00711 = -\Delta_h \cdot 0.00355$. We will have the opposite situation in case of an offset in the direction of the GNSS vector. Now we assume $\underline{\Delta} = [0, \Delta_p]^T$. According to (24), we get now $\delta_p = -\Delta_p \cdot 0.5 \cdot (s/R_s)^2; \delta_{\Delta h} = -\Delta_p \cdot s/R_s$. As can be observed, the impact of horizontal movement to change the arc length on the ellipsoid (sphere) is negligible (situation illustrated in Figure 2b), while the ellipsoidal heights difference becomes important.

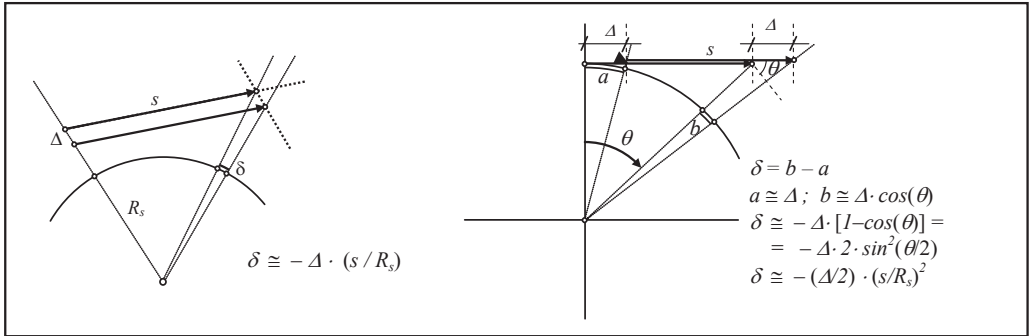

Fig. 2a, b. The impact of the vertical (a) or horizontal (b) displacement of the GNSS vector on the length of the arc on the reference surface, assuming that the beginning and end point of the vector are projected according to the principle of *Helmert*

As can be seen, errors in determining the position of the GNSS vector can significantly affect the pseudo-observations in the ellipsoidal system created on the basis of this vector. This applies in particular to differences in the geodetic coordinates. The size $\eta = s / R_s$ is the ratio of the maximum propagation of vector position errors on the errors of specified pseudo-observations expressed in the lengths of arcs on the reference surface. As will be shown in the next section, the above rule concerning the propagation of a position error of the GNSS vector will also apply to the geodesic parameters.

2.2.3. Distortion of geodesic parameters

Similarly as in Section 2.2.2, we assume some translation of the GNSS vector and use the general relationship (19). Now we apply the differential equations for the geodesic length and azimuth (see e.g. Warchałowski, 1952) by exchange of angle differentials on the differentials of arcs:

$$\delta_{s_{ij}} = -c_{ij} \cdot \delta_{b_i} - d_{ij} \cdot \delta_{l_i} - c_{j_i} \cdot \delta_{b_j} - d_{j_i} \cdot \delta_{l_j}, \tag{26}$$

$$\delta_{q_{ij}} = \delta_{q_{ji}} \cdot s_{ij} = d_{ij} \cdot \delta_{b_i} - c_{ij} \cdot \delta_{l_i} + d_{j_i} \cdot \delta_{b_j} - c_{j_i} \cdot \delta_{l_j}, \tag{27}$$

where:

- $\delta_{s_{ij}}$ = the differential of the geodesic length s_{ij} ;
- $\delta_{q_{ij}}$ = the differential of the geodesic azimuth and $\delta_{q_{ji}}$ = the correspond length of the small arc;
- $\delta_{b_k} = R_M(B_k^{(0)}) \cdot \delta_{B_k}$; $\delta_{l_k} = R_N(B_k^{(0)}) \cdot \cos(B_k^{(0)}) \cdot \delta_{L_k}$ ($k = i, j$);
- $c_{ij} = \cos(\alpha_{ij}^{(0)})$; $d_{ij} = \sin(\alpha_{ij}^{(0)})$;
- (c_{j_i} , d_{j_i} analogically after exchange of indices);

Taking (26), (27) and the equation for the height difference we can write in the matrix notation:

$$\begin{bmatrix} \delta_{sij} \\ \delta_{qij} \\ \delta_{\Delta hij} \end{bmatrix} = \begin{bmatrix} -c_{ij} & -d_{ij} & 0 \\ d_{ij} & -c_{ij} & 0 \\ 0 & 0 & -1 \end{bmatrix} \cdot \begin{bmatrix} \delta_{bi} \\ \delta_{ji} \\ \delta_{hi} \end{bmatrix} + \begin{bmatrix} -c_{ji} & -d_{ji} & 0 \\ d_{ji} & -c_{ji} & 0 \\ 0 & 0 & 1 \end{bmatrix} \cdot \begin{bmatrix} \delta_{bj} \\ \delta_{ij} \\ \delta_{hj} \end{bmatrix} \quad (28)$$

or symbolic

$$\delta_{ij} = d_{ij} \cdot \delta_{ei} + d_{ji} \cdot \delta_{ej} \quad (29)$$

Simplifying, as in (16), $\underline{C} \cdot \underline{C}^{-1} \approx \underline{I}$, we obtain $\delta_e \approx \underline{U}^T \cdot \underline{A}_R$ and

$$\delta_{ij} = d_{ij} \cdot \underline{U}_i^T \cdot \underline{A}_{Ri} + d_{ji} \cdot \underline{U}_j^T \cdot \underline{A}_{Rj} = (d_{ij} \cdot \underline{U}_i^T + d_{ji} \cdot \underline{U}_j^T) \cdot \underline{A}_R \quad (30)$$

(translation vector is identical for both points $\underline{A}_{Ri} = \underline{A}_{Rj} = \underline{A}_R$). If the approximated reference surface is the sphere with some radius R_s , as in Section 2.2.2, we can assume without loss of generality of the solution, that $B_i = 0, L_i = L_j = 0, B_j = B_i + \Delta B_{ij} = \Delta B_{ij}$,

$$\underline{U}_i^T = \begin{bmatrix} 0 & 0 & 1 \\ 0 & 1 & 0 \\ 1 & 0 & 0 \end{bmatrix}, \quad \underline{U}_j^T = \begin{bmatrix} -\sin(\Delta B_{ij}) & 0 & \cos(\Delta B_{ij}) \\ 0 & 1 & 0 \\ \cos(\Delta B_{ij}) & 0 & \sin(\Delta B_{ij}) \end{bmatrix} \quad (31)$$

Taking into account the simplifications: $\sin(\Delta B) \approx s/R_s, d_{ji} \approx -d_{ij}$, and omitting of points indices (i, j), we obtain from (30):

$$\delta \cong \begin{bmatrix} -c \cdot (s/R_s) & 0 & -c \cdot (s/R_s)^2 \cdot (1/2) \\ d \cdot (s/R_s) & 0 & d \cdot (s/R_s)^2 \cdot (1/2) \\ -(s/R_s)^2 \cdot (1/2) & 0 & (s/R_s) \end{bmatrix} \cdot \begin{bmatrix} \Delta_X \\ \Delta_Y \\ \Delta_Z \end{bmatrix} = [*] \cdot \underline{A}_R \quad (32)$$

where $\delta = [\delta_s, \delta_q, \delta_{\Delta h}]^T$ and the symbol [*] replaces the corresponding matrix. Given that $|c|, |d| \leq 1$, we can estimate from (32) the maximum errors:

$$\begin{aligned} |\delta_s|, |\delta_q| &\leq \eta \cdot [|\Delta_X| + (1/2) \cdot \eta \cdot |\Delta_Z|] \\ |\delta_{\Delta h}| &\leq \eta \cdot [|\Delta_Z| + (1/2) \cdot \eta \cdot |\Delta_X|] \end{aligned} \quad (33)$$

where $\eta = s/R_s$, as in (25). For example: let $s = 536.7$ km (as in Table 2), $R_s \approx 6385$ km then $s/R_s \approx 0.08425$ and $(s/R_s)^2 \approx 0.007098$. Assuming: $\Delta_X = 2^{1/2}, \Delta_Y = 0, \Delta_Z = 1$ with the length $|\underline{A}_R| = 3^{1/2}$ (as in Table 1) we obtain: $|\delta_s|, |\delta_q| \leq 0.12$ m and $|\delta_{\Delta h}| \leq 0.09$ m .

As in the case of the differences of geodetic coordinates as pseudo-observations, the parameters of a geodesic also have the same distortions arising from errors of the GNSS vector position. The error propagation depends significantly from size $\eta = s/R_s$. Fallacy in determining the position of the GNSS vectors is a matter of the precision of the approximate coordinates of points, as the necessary initial information in solution of the nonlinear observational system of a geodetic network. The iterative Gauss-Newton procedure (e.g. Deutsch, 1965) is usually used for this purpose. If the process is convergent, subsequent iterations are followed by an improvement in the accuracy of the approximate coordinates, and thus, at some point, the ability to re-verify and determine the pseudo-observation.

2.3. Observational equations and covariance matrices for used pseudo-observations

2.3.1. Geodetic coordinates differences

The vector of differences of geodetic coordinates $\Delta \mathbf{E}_{ij} = [\Delta B_{ij}, \Delta L_{ij}, \Delta h_{ij}]^T$, created by the projection of the Cartesian vector $\Delta \mathbf{R}_{ij} = [\Delta X_{ij}, \Delta Y_{ij}, \Delta Z_{ij}]^T$ on the reference ellipsoid is a vectorial pseudo-observation, for which the “observational” equation expresses the simple formula:

$$\Delta \mathbf{E}_{ij} + \mathbf{v}_{ij} = \mathbf{E}_j - \mathbf{E}_i \tag{34}$$

or in the differential form

$$\mathbf{v}_{ij} = d\mathbf{E}_j - d\mathbf{E}_i + \mathbf{w}_{ij}; \mathbf{w}_{ij} = \Delta \mathbf{E}_{ij}^{(0)} - \Delta \mathbf{E}_{ij} = (\mathbf{E}_j^{(0)} - \mathbf{E}_i^{(0)}) - \Delta \mathbf{E}_{ij} \tag{35}$$

where: i, j – are the indices of network points; $\Delta \mathbf{E}_{ij} = [\Delta B_{ij}, \Delta L_{ij}, \Delta h_{ij}]^T$ is the pseudo-observation (the result of the transformation from Cartesian GNSS vector); $\mathbf{E}_j^{(0)}$, $\mathbf{E}_i^{(0)}$ – the approximate geodetic coordinates; $d\mathbf{E}_j$, $d\mathbf{E}_i$ – unknown corrections to the approximated geodetic coordinates, $\mathbf{E}_k = \mathbf{E}_k^{(0)} + d\mathbf{E}_k$ (for $k=i, j$); \mathbf{v}_{ij} – observational correction; \mathbf{w}_{ij} – free component of the equation. The scalar equations corresponding to (35) are expressed as follows:

$$\begin{aligned} v_{ij}^{(B)} &= dB_j - dB_i - w_{ij}^{(B)}, & w_{ij}^{(B)} &= \Delta B_{ij} - (B_j^{(0)} - B_i^{(0)}), \\ v_{ij}^{(L)} &= dL_j - dL_i - w_{ij}^{(L)}, & w_{ij}^{(L)} &= \Delta L_{ij} - (L_j^{(0)} - L_i^{(0)}), \\ v_{ij}^{(h)} &= dh_j - dh_i - w_{ij}^{(h)}, & w_{ij}^{(h)} &= \Delta h_{ij} - (h_j^{(0)} - h_i^{(0)}) \end{aligned} \tag{36}$$

for some $(i, j) \in \pi$ (a plan of pseudo-observations as a set of indices pairs of GNSS vectors).

The sub-vectors of residues $\mathbf{v}_{ij} = [v_{ij}^{(B)}, v_{ij}^{(L)}, v_{ij}^{(h)}]^T$ create the vector \mathbf{V}_I according to the accepted order of equations. Similarly, the sub-vectors $\mathbf{w}_{ij} = [w_{ij}^{(B)}, w_{ij}^{(L)}, w_{ij}^{(h)}]^T$ create the vector of free components \mathbf{W}_I (components of the vector are the differences between the pseudo-observations and corresponding measures calculated on the basis of approximate coordinates).

Along with the transformation of $\mathbf{AR} \Rightarrow \mathbf{AE}$ done in order to transform the corresponding covariance matrices: $\mathbf{Cov}(\mathbf{AR}) \Rightarrow \mathbf{Cov}(\mathbf{AE})$. This matrix is needed as a part of a stochastic model of observational system for its adjustment using the least squares method. For this purpose, based on (1), (2), (3), (10) we can write the relationship between Cartesian vector components \mathbf{AR} and differences of geodetic coordinates \mathbf{AE} using points indices (for clarity):

$$\begin{aligned} \Delta X_{ij} &= (R_N(j) + h_i^{(0)} + \Delta h_{ij}) \cdot \cos(B_i^{(0)} + \Delta B_{ij}) \cdot \cos(L_i^{(0)} + \Delta L_{ij}) - X_i^{(0)} \\ \Delta Y_{ij} &= (R_N(j) + h_i^{(0)} + \Delta h_{ij}) \cdot \cos(B_i^{(0)} + \Delta B_{ij}) \cdot \sin(L_i^{(0)} + \Delta L_{ij}) - Y_i^{(0)} \\ \Delta Z_{ij} &= [R_N(j) \cdot (1 - e^2) + h_i^{(0)} + \Delta h_{ij}] \cdot \sin(B_i^{(0)} + \Delta B_{ij}) - Z_i^{(0)} \\ &(\text{for } R_N(j) = a / [1 - e^2 \cdot \sin^2(B_i^{(0)} + \Delta B_{ij})]^{1/2}) \end{aligned} \tag{37}$$

Similarly to (19), we can determine the relationship between the random errors $\underline{\boldsymbol{\varepsilon}}(\mathbf{AR})$, $\underline{\boldsymbol{\varepsilon}}(\mathbf{AE})$ of the vectors \mathbf{AR} and \mathbf{AE} , and then between the covariance matrices of these vectors. We are not interested in this case, however, the impact of the position error of the vector \mathbf{AR} (its shift in Cartesian space) but only to the same errors of its components. Therefore, we assume now that the starting point of the vector is correct, and the errors coordinates of the end point are equal to the errors of the vector components. Considering (19), (37), we determine at first the relationship between the errors:

$$\underline{\boldsymbol{\varepsilon}}(\mathbf{AE}) = \begin{bmatrix} \varepsilon(\Delta B) \\ \varepsilon(\Delta L) \\ \varepsilon(\Delta h) \end{bmatrix} = \mathbf{C}^{-1} \cdot \mathbf{U}^T \cdot \begin{bmatrix} \varepsilon(\Delta X) \\ \varepsilon(\Delta Y) \\ \varepsilon(\Delta Z) \end{bmatrix} = \mathbf{C}^{-1} \cdot \begin{bmatrix} \varepsilon(\Delta b) \\ \varepsilon(\Delta l) \\ \varepsilon(\Delta h) \end{bmatrix} = \mathbf{C}^{-1} \cdot \underline{\boldsymbol{\varepsilon}}(\mathbf{A}) \tag{38}$$

where the matrices \mathbf{C} and \mathbf{U} are defined by the formulas (12) – (14), but here for the end point of the vector and its geodetic coordinates:

$$B = B_i^{(0)} + \Delta B_{ij}; L = L_i^{(0)} + \Delta L_{ij}; h = h_i^{(0)} + \Delta h_{ij} \tag{39}$$

On the basis of the equation (38), we obtain the standard formula for the covariance matrix:

$$\mathbf{Cov}(\mathbf{AE}) = \mathbf{C}^{-1} \cdot \mathbf{U}^T \cdot \mathbf{Cov}(\mathbf{AR}) \cdot \mathbf{U} \cdot \mathbf{C}^{-1} = \mathbf{C}^{-1} \cdot \mathbf{Cov}(\mathbf{Ae}) \cdot \mathbf{C}^{-1} \tag{40}$$

or taking into account (16):

$$\mathbf{Cov}(\mathbf{Ae}) = \underline{\mathbf{C}} \cdot \mathbf{Cov}(\mathbf{AE}) \cdot \underline{\mathbf{C}}$$

where the vector $\Delta \mathbf{e} = [\Delta b, \Delta l, \Delta h]^T$ with respect to $\Delta \mathbf{E} = [\Delta B, \Delta L, \Delta h]^T$ is the conversion of the increments of the geodetic coordinates on the corresponding arcs lengths of the meridian and parallel.

According to standard rules for unbiased estimators in the least squares method, the weight sub-matrix for the vector $\Delta \mathbf{E}_{ij}$ should be the inverse of the covariance matrix:

$$\begin{aligned}
 P(\Delta \mathbf{E}_{ij}) &= \text{Cov}^{-1}(\Delta \mathbf{E}_{ij}) = \mathbf{C}_j \cdot \mathbf{U}_j^T \cdot \text{Cov}^{-1}(\Delta \mathbf{R}_{ij}) \cdot \mathbf{U}_j \cdot \mathbf{C}_j \\
 P(\Delta \mathbf{e}_{ij}) &= \underline{\mathbf{C}}_j^{-1} \cdot P(\Delta \mathbf{E}_{ij}) \cdot \underline{\mathbf{C}}_j^{-1}
 \end{aligned}
 \tag{41}$$

(note that \mathbf{C}_j is the diagonal matrix and \mathbf{U}_j – the orthonormal matrix, calculated in the point j)

2.3.2. Geodesic parameters

Similarly to the formula (35), the observational equation for geodesic elements can be written in the form:

$$\mathbf{v}_{ij} = \mathbf{d}_{ij} \cdot \mathbf{C}_i^{-1} \cdot \mathbf{dE}_i + \mathbf{d}_{ji} \cdot \mathbf{C}_j^{-1} \cdot \mathbf{dE}_j - \mathbf{w}_{ij}; \quad \mathbf{w}_{ij} = \mathbf{G}_{ij} - \mathbf{G}_{ij}^{(0)}
 \tag{42}$$

where the matrix \mathbf{C} is expressed by the formula (12) and

$$\mathbf{d}_{pq} = \begin{bmatrix} -c_{pq} & -d_{pq} & 0 \\ d_{pq} & -c_{pq} & 0 \\ 0 & 0 & f_{pq} \end{bmatrix} \quad \text{for } (p,q) = (i,j) \text{ or } (j,i)
 \tag{43}$$

$$\begin{aligned}
 c_{pq} &= \cos(\alpha_{pq}^{(0)}); \quad d_{pq} = \sin(\alpha_{pq}^{(0)}); \quad \text{for } (p,q) = (i,j) \text{ or } (j,i); \\
 f_{ij} &= -1, \quad f_{ji} = 1;
 \end{aligned}$$

$\mathbf{G}_{ij} = [s_{ij}, \alpha_{ij}, \Delta h_{ij}]^T$ = the vector of pseudo-observations with the covariance matrix (46)

$\mathbf{G}_{ij}^{(0)} = [s_{ij}^{(0)}, \alpha_{ij}^{(0)}, \Delta h_{ij}^{(0)}]^T$ = the vector of measures obtained from approximated coordinates,

on the basis known in geodesy scalar functions for geodesics:

$$\begin{aligned}
 s_{ij}^{(0)} &= G_1(B_i^{(0)}, L_i^{(0)}, B_j^{(0)}, L_j^{(0)}) && = \text{the length of a geodesic segment (between two points),} \\
 \alpha_{ij}^{(0)} &= G_2(B_i^{(0)}, L_i^{(0)}, B_j^{(0)}, L_j^{(0)}) && = \text{azimuth at the beginning point of geodesic segment,} \\
 \Delta h_{ij}^{(0)} &= h_j^{(0)} - h_i^{(0)} && = \text{the ellipsoidal heights difference.}
 \end{aligned}$$

We have taken into account the formulas (26), (27), which express the relationship between the errors of the *Cartesian* coordinates and the corresponding errors of the geodesic parameters, i.e. the length and azimuth (expressed as the length of the arc) and the error of difference of geodetic heights. As in the formula (38), it can be written that the relationship between the errors of the geodetic coordinates and the errors of the geodesic parameters, assuming that the starting point of the vector is constant:

$$\begin{aligned} \varepsilon(s_{ij}) &= -c_{ji} \cdot \varepsilon(b_j) - d_{ji} \cdot \varepsilon(l_j) \\ \varepsilon(q_{ij}) &= \varepsilon(\alpha_{ji}) \cdot s_{ij} = d_{ji} \cdot \varepsilon(b_j) - c_{ji} \cdot \varepsilon(l_j) \\ \varepsilon(\Delta h_{ij}) &= \varepsilon(h_j) \end{aligned} \tag{44}$$

Considering three components we write (44) in the matrix form:

$$\underline{\varepsilon} = \begin{bmatrix} -c & -d & 0 \\ d & -c & 0 \\ 0 & 0 & 1 \end{bmatrix} \cdot \begin{bmatrix} \varepsilon(b) \\ \varepsilon(l) \\ \varepsilon(h) \end{bmatrix} = \mathbf{d} \cdot \underline{\varepsilon}(e) = \mathbf{d} \cdot \mathbf{U}^T \cdot \underline{\varepsilon}(\Delta \mathbf{R}), \tag{45}$$

$$c = \cos(\alpha^{(0)}), \quad d = \sin(\alpha^{(0)}),$$

where \mathbf{d} is an orthonormal matrix ($\mathbf{d}^{-1} = \mathbf{d}^T$). Hence we obtain the following covariance matrix:

$$\text{Cov}(\underline{\varepsilon}) = \mathbf{d} \cdot \mathbf{U}^T \cdot \text{Cov}(\Delta \mathbf{R}) \cdot \mathbf{U} \cdot \mathbf{d}^T \tag{46}$$

3. Original Cartesian vector in ellipsoidal space

The original GNSS vector $\Delta \mathbf{R}_{ij} = [\Delta X_{ij}, \Delta Y_{ij}, \Delta Z_{ij}]^T$ ((i, j) – a pair of indices of network points) determines in Cartesian geocentric frame the simple linear observational equation (see e.g. Hofmann- Wellenhof et al., 2008):

$$\Delta \mathbf{R}_{ij} + \mathbf{v}_{ij} = \mathbf{R}_j - \mathbf{R}_i \tag{47}$$

with the covariance matrix $\text{cov}(\Delta \mathbf{R}_{ij})$ required together with the vector $\Delta \mathbf{R}_{ij}$ within the framework of GNSS post-processing. In the equation (47) denoted: \mathbf{v}_{ij} – sub-vector of observational corrections, $\mathbf{R}_k = [X_k, Y_k, Z_k]^T$ ($k = i, j$) – calculated or defined as fixed (reference) points. To convert the equation (47) to the ellipsoidal frame, we use approximated coordinates with unknown corrections and the relationship similar to (8):

$$\mathbf{R}_k = \mathbf{R}_k^{(0)} + d\mathbf{R}_k = \mathbf{R}_k^{(0)} + d\mathbf{R}_k = \mathbf{R}_k^{(0)} + \mathbf{J}(\mathbf{E}_k) \cdot d\mathbf{E}_k \text{ (for } k = i, j) \tag{48}$$

Substituting (48) in (47), we obtain vectorial observational equation, where the new unknowns are corrections to the approximate value of geodetic coordinates:

$$\mathbf{v}_{ij} = \mathbf{J}(\mathbf{E}_j) \cdot d\mathbf{E}_j - \mathbf{J}(\mathbf{E}_i) \cdot d\mathbf{E}_i - \mathbf{w}_{ij}; \tag{49}$$

$$\mathbf{w}_{ij} = -(\Delta\mathbf{R}_{ij} - \Delta\mathbf{R}_{ij}^{(0)}) = -[\Delta\mathbf{R}_{ij} - (\mathbf{R}_j^{(0)} - \mathbf{R}_i^{(0)})] \tag{50}$$

Then, after taking into account the equation (12), (13), (15) we get:

$$\mathbf{v}_{ij} = \mathbf{U}_j \cdot \mathbf{C}_j \cdot d\mathbf{E}_j - \mathbf{U}_i \cdot \mathbf{C}_i \cdot d\mathbf{E}_i - \mathbf{w}_{ij}; \tag{51}$$

In the development to a scalar form, the equations for three components of GNSS vector will be:

$$\begin{aligned} v_{ij}^{(X)} = & + \sin(B_i) \cdot \cos(L_i) \cdot (R_M^{(i)} + h_i) \cdot dB_i + \sin(L_i) \cdot \cos(B_i) \cdot (R_N^{(i)} + h_i) \cdot dL_i - \cos(L_i) \cdot \cos(B_i) \cdot dh_i + \\ & - \sin(B_j) \cdot \cos(L_j) \cdot (R_M^{(j)} + h_j) \cdot dB_j - \sin(L_j) \cdot \cos(B_j) \cdot (R_N^{(j)} + h_j) \cdot dL_j + \cos(L_j) \cdot \cos(B_j) \cdot dh_j + \\ & - [\Delta X_{ij} - (X_j^{(0)} - X_i^{(0)})] = \\ = & + \sin(B_i) \cdot \cos(L_i) \cdot \mu_i \cdot db_i + \sin(L_i) \cdot v_i \cdot dl_i - \cos(L_i) \cdot \cos(B_i) \cdot dh_i + \\ & - \sin(B_j) \cdot \cos(L_j) \cdot \mu_j \cdot db_j - \sin(L_j) \cdot v_j \cdot dl_j + \cos(L_j) \cdot \cos(B_j) \cdot dh_j + \\ & - [\Delta X_{ij} - (X_j^{(0)} - X_i^{(0)})], \\ v_{ij}^{(Y)} = & + \sin(B_i) \cdot \sin(L_i) \cdot (R_M^{(i)} + h_i) \cdot dB_i - \cos(L_i) \cdot \cos(B_i) \cdot (R_N^{(i)} + h_i) \cdot dL_i - \sin(L_i) \cdot \cos(B_i) \cdot dh_i + \\ & - \sin(B_j) \cdot \sin(L_j) \cdot (R_M^{(j)} + h_j) \cdot dB_j + \cos(L_j) \cdot \cos(B_j) \cdot (R_N^{(j)} + h_j) \cdot dL_j + \sin(L_j) \cdot \cos(B_j) \cdot dh_j + \\ & - [\Delta Y_{ij} - (Y_j^{(0)} - Y_i^{(0)})] = \\ = & + \sin(B_i) \cdot \sin(L_i) \cdot \mu_i \cdot db_i - \cos(L_i) \cdot v_i \cdot dl_i - \sin(L_i) \cdot \cos(B_i) \cdot dh_i + \\ & - \sin(B_j) \cdot \sin(L_j) \cdot \mu_j \cdot db_j + \cos(L_j) \cdot v_j \cdot dl_j + \sin(L_j) \cdot \cos(B_j) \cdot dh_j + \\ & - [\Delta Y_{ij} - (Y_j^{(0)} - Y_i^{(0)})], \\ v_{ij}^{(Z)} = & - \cos(B_i) \cdot (R_M^{(i)} + h_i) \cdot dB_i - 0 \cdot dL_i - \sin(B_i) \cdot dh_i + \\ & + \cos(B_j) \cdot (R_M^{(j)} + h_j) \cdot dB_j + 0 \cdot dL_j + \sin(B_j) \cdot dh_j + \\ & - [\Delta Z_{ij} - (Z_j^{(0)} - Z_i^{(0)})] = \\ = & - \cos(B_i) \cdot \mu_i \cdot db_i - 0 \cdot dl_i - \sin(B_i) \cdot dh_i + \\ & + \cos(B_j) \cdot \mu_j \cdot db_j + 0 \cdot dl_j + \sin(B_j) \cdot dh_j + \\ & - [\Delta Z_{ij} - (Z_j^{(0)} - Z_i^{(0)})], \end{aligned} \tag{52}$$

where

$$\mu_k = 1 + h_k / R_M^{(k)}, v_k = 1 + h_k / R_N^{(k)} \text{ for } k = i, j \tag{53}$$

and the radii of curvature R_M, R_N are defined in the formulas (10), (13). Of course, if $h_k \rightarrow 0$ then $\mu_k \rightarrow 1$ and $v_k \rightarrow 1$.

4. Observational equations in the ellipsoidal frame for terrestrial data

The second group of observational equations concerns classic (terrestrial) observations. Observational equations for such observations on the ellipsoid can be found in textbooks for higher geodesy (see e.g.: Warchałowski, 1952; Szpunar, 1982; Leick, 2004), as well in many thematic publications in the field of geodetic network on the ellipsoid (see e.g. : Thomson, 1976; Gajderowicz, 1979, 1981). In current measuring processes, typical terrestrial observations are polar observations, that is, lengths and directions. The astronomical azimuths are no longer measured. In addition, in the third dimension, we can consider normal or orthometric height differences. Formally, we assume that the lengths and directions are reduced to the corresponding elements of geodesic. For these terrestrial observations, we give below only the final equations of observations, using the notations adopted in this paper.

The observational equation for classic polar observations (distance and direction), reduced to the geodesic on the ellipsoid has the following formulas:

$$v_{ij}^{(s)} = -c_{ij} \cdot db_i - d_{ij} \cdot dl_i - c_{ji} \cdot db_j - d_{ji} \cdot dl_j + 0 - ds_{ij} \quad (54)$$

$$v_{ij}^{(K)} = D_{ij} \cdot db_i - C_{ij} \cdot dl_i + D_{ji} \cdot db_j - C_{ji} \cdot dl_j + dz_i - dK_{ij} \quad (55)$$

where:

$c_{pq} = \cos(\alpha_{pq}^{(0)})$, $d_{pq} = \sin(\alpha_{pq}^{(0)})$, $C_{pq} = c_{pq} / s_{pq}^{(0)}$, $D_{pq} = d_{pq} / s_{pq}^{(0)}$, for $(p,q) = (i,j)$ or (j, i) ;

$ds_{ij} = s_{ij}^{(obs.)} - s_{ij}^{(0)}$ – free component of the equation (54) in which:

$s_{ij}^{(obs.)}$ – the observation as the length of the geodesic segment on the ellipsoid,

$s_{ij}^{(0)}$ – the approximate measure as the length of the geodesic segment, determined by the approximate coordinates $(B_i^{(0)}, L_i^{(0)})$, $(B_j^{(0)}, L_j^{(0)})$;

$\alpha_{ij}^{(0)}$, $\alpha_{ji}^{(0)}$ – the azimuth (start and return) the geodesic segment, calculated from approximated coordinates $(B_i^{(0)}, L_i^{(0)})$, $(B_j^{(0)}, L_j^{(0)})$;

$dK_{ij} = K_{ij}^{(obs.)} - K_{ij}^{(0)}$ – free component of the equation (55), in which:

$K_{ij}^{(obs.)}$ – directional observation, $K_{ij}^{(0)} = \alpha_{ij}^{(0)} - z_i^{(0)}$,

$z_i^{(0)}$ – the approximate value of the orientation constant of the directions set on the station;

dz_i – the unknown correction for the approximate orientation constant;

db_k , dl_k – small arcs of a meridian and parallel, replacing the corrections dB_k , dL_k to approximate geodetic coordinates $(B_k^{(0)}, L_k^{(0)})$, by the formulas (similarly to (17)): $db_k = R_M(k) \cdot dB_k$, $dl_k = R_N(k) \cdot \cos(B_k) \cdot dL_k$ (for the point index $k = i, j$), $R_N^{(k)}$, $R_M^{(k)}$ – principal radii of curvature (for $k = i, j$) predetermined by formulas (10), (13).

Creating the differences of equations (55) on a single station we obtain the observational equations for angles. Thus, the orientation constants of direction are eliminated as the parameters, which have no practical significance (so-called nuisance

parameter). Various strategies are used in order to preserve the equivalence of the angles and directions of observations in terms of the result of a network adjustment with the least squares method. One way is to create the set of so-called Schreiber’s angles which enable to use the diagonal weighting matrix for created angles (Kadaj, 2008).

A specific problem is the integration of classical leveling with ellipsoidal (geometric) height differences, which are the results of use of GNSS vectors. For this purpose we use a numeric model of a local quasi-geoid, which gives the relationship between ellipsoidal and normal heights. We use the following linear equation:

$$v_{ij}^{(h)} = -\delta h_i + \delta h_j - w_{ij}; w_{ij} = [(\Delta H_{ij} + \Delta \zeta_{ij}) - (h_j^{(0)} - h_i^{(0)})] \tag{56}$$

where: ΔH_{ij} is the normal height difference measured in a terrestrial leveling, $\Delta \zeta_{ij} = \zeta_j - \zeta_i$ is the height anomalies difference (we assume, that the point anomalies are known from a numerical quasi-geoid model); $h_i^{(0)}, h_j^{(0)}$ are the estimated ellipsoidal heights; $\delta h_i, \delta h_j$ – the unknown corrections for approximated ellipsoidal heights.

5. The adjustment models of combined networks on the ellipsoid

Observational equations will be created independently for two integrated subsets of observations, a pseudo-observations derived from the GNSS vectors and classic observations. The linearized system of observational equations can be shown in the matrix notation with the corresponding blocks for the two subsets (subsets):

$$V = A \cdot dE - W, \text{ with the weighting matrix } P \tag{57}$$

$$V = \begin{bmatrix} V_1 \\ \text{---} \\ V_2 \end{bmatrix}, \quad W = \begin{bmatrix} W_1 \\ \text{---} \\ W_2 \end{bmatrix}, \quad P = \begin{bmatrix} P_1 & \text{---} \\ \text{---} & \text{---} \\ & P_2 \end{bmatrix}, \quad A = \begin{bmatrix} A_1 \\ \text{---} \\ A_2 \end{bmatrix},$$

where index 1 refers to GNSS observations, index 2 – refers to classic terrestrial observations. In general, the individual sizes denote: V – vector of corrections, W – vector of free components, A – matrix of coefficients, dE – unknown vector of corrections to approximate geodetic coordinates $E^{(0)}$,

$$dE = [dB_1, dL_1, dh_1, dB_2, dL_2, dh_2, \dots, dB_r, dL_r, dh_r]^T$$

(without components for fixed points, for example with index $k = r+1, r+2, \dots, p$ or by assuming the alternative equations $dB_k = 0, dL_k = 0, dh_k = 0$ with large numeric weights)

The matrix A have a similar block structure, as shown in Figure 3

For the correctly defined system, the matrix A , of the dimensions $(m \times n)$ ($m \geq n$) is full rank, $rank(A) = n$, so the method of least squares, $V^T \cdot P \cdot V = min.$, theoretically leads to the uniqueness of the solution (57). Such a task, however, has the disadvantage that the vector of the system of unknowns dE is not uniform in terms of the type of components (angles and lengths) with the result that is obtained in solving the equations system, which has a significant disparity between diagonal elements of the normal matrix. This may lead to a certain instability of the solution. To avoid this situation we can replace the vector dE with the homogeneous vector de (small arcs db, dl on the ellipsoid and height corrections dh), adopting the formula (16):

$$de = \underline{C} \cdot dE \tag{58}$$

where the diagonal matrix \underline{C} is defined by the formula (15). Substituting this relation in the equation (57) we get:

$$V = A \cdot \underline{C}^{-1} \cdot de - W = a \cdot de - W, \text{ with a weight matrix } P \tag{59}$$

$$(a = A \cdot \underline{C}^{-1})$$

From the normal equations we determine the indirect unknowns but by the relation (58) we continue corrections of the original coordinates:

$$de = (a^T \cdot P \cdot a)^{-1} \cdot a^T \cdot P \cdot W \tag{60}$$

$$dE = \underline{C}^{-1} \cdot de$$

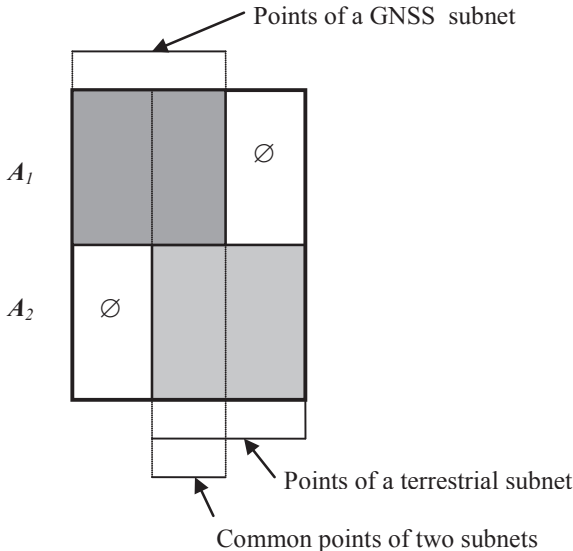

Fig. 3. The structure of the coefficient matrix of observational equations for a combined network. The rows correspond to the equations, the columns – unknown corrections to the approximate geodetic coordinates

Note that in the task specified in the above matrices, the vector W is included depending on the actual approximate coordinates of the network points. In order to eliminate possible errors, linearization (rejection of non-linear components in the Taylor series expansions) in computer implementations is applied in the iterative Gauss-Newton procedure. Denoting by the index k of an iterative cycle, this procedure can be written as follows:

$$\begin{aligned}
 E_{k+1} &= E_k + dE_{k,k+1} \\
 dE_{k,k+1} &= \underline{C}_k^{-1} \cdot de_{k,k+1} \\
 de_{k,k+1} &= (a_k^T \cdot P \cdot a_k)^{-1} \cdot a_k^T \cdot P \cdot W_k
 \end{aligned} \tag{61}$$

$k = 0, 1, 2 \dots$

A stopping criterion of the iterative process (61) reduces to control an increment norm of the unknown vector in the sense of inequality $\| de_{k,k+1} \| < \varepsilon$ where ε is a maximal numerical error. Such a stopping criterion is sufficient for the convergence of the square type, when the condition “smallness” of growth between successive iterations also means the proximity to the border point of the iteration convergence. This type of convergence is characterized by the adjustments commonly used in the geodetic network, the Gauss-Newton iterative procedure (see e.g. Deutsch, 1965).

6. Numerical tests of the network adjustment for different functional models

Four reference stations from the ASG-EUPOS system were selected, with the following names: GIZA (Giżycko), JLGR (Jelenia Gora), KOSZ (Koszalin), USDL (Ustrzyki Dolne), see Figure 4. Based on the known geocentric coordinates X, Y, Z , in the reference frame PL-ETRF2000 three-dimensional Cartesian vectors were generated “artificially”, simulating GNSS vectors according to the situation shown in Figure 4. Then, the Cartesian vectors were converted to the pseudo-observations in two alternative versions:

- a) differences in the geodetic coordinates ($\Delta B, \Delta L, \Delta h$)
- b) the lengths and azimuths of geodesics and differences of the ellipsoidal heights ($s, \alpha, \Delta h$)

Table 3 shows the original Cartesian and geodetic coordinates of the above mentioned stations. Table 4 shows the values of the observations (Cartesian vectors) and pseudo-observations in two variants, with the precision rounding to the unit in the digit at the last position (this data can optionally be helpful to perform related control tests).

According to the type of data, we consider three alternative functional models of GNSS observations (pseudo-observations) in the ellipsoidal frame (as indicated in Table 4):

- I – the original Cartesian model of GNSS vectors expressed as a function of geodetic (ellipsoidal) coordinates,
- II – the model of pseudo-observations in the form of differences in geodetic coordinates ($\Delta B, \Delta L, \Delta h$)
- III – model of pseudo-observation as geodesic parameters ($s, \alpha, \Delta h$) (the ellipsoid heights difference as in model II).

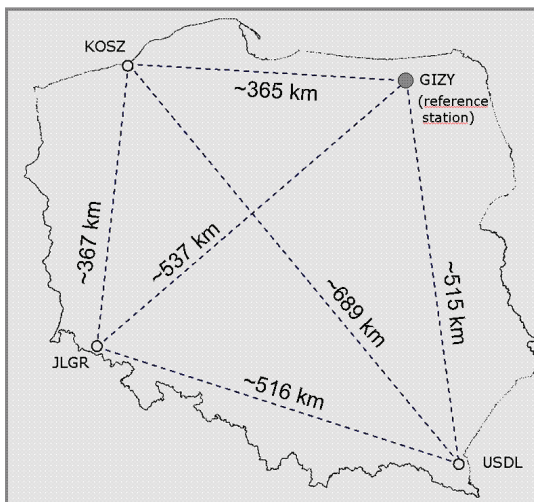

Fig. 4. Test network (ASG-EUPOS stations)

Tab. 3. Data coordinates

| Cartesian geocentric coordinates (in PL-ETRF2000) | | | | |
|---------------------------------------------------|------------------------|------------------------|---------------------|-----------|
| Name | <i>X</i> | <i>Y</i> | <i>Z</i> | <i>ID</i> |
| GIZY | 3486403.5385 | 1392187.3370 | 5139218.6640 | 1 |
| JLGR | 3878289.7496 | 1092566.8446 | 4928217.8516 | 2 |
| KOSZ | 3590530.4065 | 1042990.5409 | 5150117.6518 | 3 |
| USDL | 3837558.2233 | 1596303.0315 | 4822409.6403 | 4 |
| Geodetic coordinates and ellipsoidal heights | | | | |
| Name | <i>B</i> | <i>L</i> | <i>h</i> | <i>ID</i> |
| | [° ' "] | [° ' "] | [m] | |
| GIZY | 54 02 08.805541 | 21 46 03.962343 | 166.825 | 1 |
| JLGR | 50 55 10.050525 | 15 43 59.694227 | 408.190 | 2 |
| KOSZ | 54 12 12.190732 | 16 11 51.790188 | 123.162 | 3 |
| USDL | 49 25 58.460097 | 22 35 08.765000 | 529.742 | 4 |

Pseudo-observations of type II, III in combined (hybrid) networks were already the subject of computer implementations and testing (e.g. in the geodetic system GeoNet – www.geonet.net.pl). Therefore, we will refer mainly to the model I and presented (in Table 5), the set of coefficients and free components of observational equations expressed by the formulas (52), and then (in Tables 6 and 7) the coefficients and free components (three iterations of the Gauss-Newton process) of the system of normal equations. In the subset of 4 stations we assumed that the station with the index 1 (GIZA) is the constant (reference) point, while the other 3 stations are adjusted by the least squares method.

The implementation of the Gauss-Newton algorithm was verified by adopting approximate geodetic coordinates for stations 2, 3, 4 rounded to 1", which means the possible maximal error of the initial value of the unknowns approx. 15m is measured in the length of the arc of the ellipsoid. Indeed, in the first iteration, the maximum corrections to the approximate coordinates are close to the errors of the initial values. Table 8 summarizes the consequential corrections to the current geodetic coordinates in three iterations of the Gauss-Newton process, after which (with control in the last iteration) the geodetic coordinates corresponding to their values were given in ASG-EUPOS database.

The GeoNet program were used to calculate the network according to the models II and III. The obtained final geodetic coordinates of points 2, 3 and 4 were the same as in model I. Table 9 summarizes the comparison of three methods, the convergence parameters as an increment norm of the unknown vector (similar as for the model I – Tab. 8). We can see that in terms of the speed of convergence, the models I and II are comparable – with relatively large errors of initial values, accurate coordinates achieved after 2–3 iterations. However, the model III requires more iterations, in which the pseudo-observations are the lengths and azimuths of geodesics.

Tab. 4. Alternative sets of observations or pseudo-observations in GNSS network.

| I. Cartesian GNSS vectors with variances and covariances (we assume artificially a simple diagonal matrix \mathbf{Q}) | | | | | | |
|--------------------------------------------------------------------------------------------------------------------------|--------|--------------|--------------|--------------|---------------------------------------------------------------------------------------------------------------------------------------|---------------------|
| ID_i | ID_j | ΔX | ΔY | ΔZ | $Q_{\Delta X \Delta Y} Q_{\Delta X \Delta Z} Q_{\Delta Y \Delta Z} Q_{\Delta X \Delta X} Q_{\Delta Y \Delta Y} Q_{\Delta Z \Delta Z}$ | |
| 1 | 2 | 391886.2111 | -299620.4924 | -211000.8124 | 0.0001 | 0 0 0.0001 0 0.0001 |
| 1 | 3 | 104126.8680 | -349196.7961 | 10898.9878 | 0.0001 | 0 0 0.0001 0 0.0001 |
| 1 | 4 | 351154.6848 | 204115.6945 | -316809.0237 | 0.0001 | 0 0 0.0001 0 0.0001 |
| 2 | 3 | -287759.3431 | -49576.3037 | 221899.8002 | 0.0001 | 0 0 0.0001 0 0.0001 |
| 2 | 4 | -40731.5263 | 503736.1869 | -105808.2113 | 0.0001 | 0 0 0.0001 0 0.0001 |
| 3 | 4 | 247027.8168 | 553312.4906 | -327708.0115 | 0.0001 | 0 0 0.0001 0 0.0001 |

| II. Differences of geodetic coordinates with variances and covariances (after conversion from I) | | | | | | |
|--------------------------------------------------------------------------------------------------|--------|---------------------|---------------------|----------------|---------------------------------------------------------------------------------------------------------------------------------------|-------------------------|
| ID_i | ID_j | $\Delta B [^\circ]$ | $\Delta L [^\circ]$ | $\Delta h [m]$ | $Q_{\Delta B \Delta B} Q_{\Delta B \Delta L} Q_{\Delta B \Delta h} Q_{\Delta L \Delta L} Q_{\Delta L \Delta h} Q_{\Delta h \Delta h}$ | |
| 1 | 2 | -11218.755016 | -21724.268116 | 241.3645 | 1.047E-7 | 0 0 2.621E-7 0 1.000E-4 |
| 1 | 3 | 603.385191 | -20052.172155 | -43.6633 | 1.046E-7 | 0 0 3.043E-7 0 1.000E-4 |
| 1 | 4 | -16570.345444 | 2944.802657 | 362.9168 | 1.048E-7 | 0 0 2.463E-7 0 1.000E-4 |
| 2 | 3 | 11822.140207 | 1672.095961 | -285.0278 | 1.046E-7 | 0 0 3.043E-7 0 1.000E-4 |
| 2 | 4 | -5351.590428 | 24669.070773 | 121.5523 | 1.048E-7 | 0 0 2.462E-7 0 1.000E-4 |
| 3 | 4 | -17173.730635 | 22996.974812 | 406.5801 | 1.048E-7 | 0 0 2.462E-7 0 1.000E-4 |

| III. Geodesic parameters with variances and covariances | | | | | | |
|---------------------------------------------------------|--------|-----------------------------|----------------|----------------|---------------------------------------------------------------------------------------------------|-------------------------|
| ID_i | ID_j | $\alpha [^\circ]$ (azimuth) | s [m] (length) | $\Delta h [m]$ | $Q_{\alpha \alpha} Q_{\alpha s} Q_{\alpha \Delta h} Q_{s s} Q_{s \Delta h} Q_{\Delta h \Delta h}$ | |
| 1 | 2 | 2580239.1082 | 536668.1199 | 241.3645 | 1.407E-4 | 0 0 1.000E-4 0 1.000E-4 |
| 1 | 3 | 3057635.2998 | 364595.1649 | -43.6633 | 3.049E-4 | 0 0 1.000E-4 0 1.000E-4 |
| 1 | 4 | 1926378.3722 | 515224.3463 | 362.9168 | 1.527E-4 | 0 0 1.000E-4 0 1.000E-4 |
| 2 | 3 | 52676.8427 | 366781.3742 | -285.0278 | 3.013E-4 | 0 0 1.000E-4 0 1.000E-4 |
| 2 | 4 | 1177841.6782 | 516440.6348 | 121.5523 | 1.520E-4 | 0 0 1.000E-4 0 1.000E-4 |
| 3 | 4 | 1530106.6416 | 689191.1629 | 406.5801 | 8.533E-5 | 0 0 1.000E-4 0 1.000E-4 |

Tab. 5. Coefficients of observational equations in input data

| Equation | Elements of the matrix a (multiplied by unknown corrections) | | | | | | | | | | Vector W <i>w</i> [m] |
|-----------------------------|------------------------------------------------------------------------|------------------------|------------------------|------------------------|------------------------|------------------------|------------------------|------------------------|------------------------|----------|---------------------------------|
| | <i>db</i> ₂ | <i>dl</i> ₂ | <i>dh</i> ₂ | <i>db</i> ₃ | <i>dl</i> ₃ | <i>dh</i> ₃ | <i>db</i> ₄ | <i>dl</i> ₄ | <i>dh</i> ₄ | <i>w</i> | |
| <i>v</i> _x (1-2) | -0.747178 | -0.271156 | 0.606794 | 0 | 0 | 0 | 0 | 0 | 0 | 0 | 4.728675 |
| <i>v</i> _y (1-2) | -0.210488 | 0.962535 | 0.170940 | 0 | 0 | 0 | 0 | 0 | 0 | 0 | -12.756999 |
| <i>v</i> _z (1-2) | 0.630412 | 0 | 0.776260 | 0 | 0 | 0 | 0 | 0 | 0 | 0 | -1.131744 |
| <i>v</i> _x (1-3) | 0 | 0 | 0 | -0.778902 | -0.278949 | 0.561693 | 0 | 0 | 0 | 0 | 8.498078 |
| <i>v</i> _y (1-3) | 0 | 0 | 0 | -0.226255 | 0.960306 | 0.163160 | 0 | 0 | 0 | 0 | -12.447235 |
| <i>v</i> _z (1-3) | 0 | 0 | 0 | 0.584910 | 0 | 0.811098 | 0 | 0 | 0 | 0 | -3.580844 |
| <i>v</i> _x (1-4) | 0 | 0 | 0 | 0 | 0 | 0 | -0.701384 | 0.600463 | 0.249771 | 0.600463 | 15.445173 |
| <i>v</i> _y (1-4) | 0 | 0 | 0 | 0 | 0 | 0 | -0.291751 | 0.923307 | 0.249771 | 0.249771 | -10.270865 |
| <i>v</i> _z (1-4) | 0 | 0 | 0 | 0 | 0 | 0 | 0.650340 | 0.759643 | 0.759643 | 0.759643 | -9.808599 |
| <i>v</i> _x (2-3) | 0.747178 | 0.271156 | 0.606794 | -0.778902 | -0.278949 | 0.561693 | 0 | 0 | 0 | 0 | 3.769404 |
| <i>v</i> _y (2-3) | 0.210488 | -0.962535 | 0.170940 | -0.226255 | 0.960306 | 0.163160 | 0 | 0 | 0 | 0 | 0.309764 |
| <i>v</i> _z (2-3) | -0.630412 | 0 | 0.776260 | 0.584910 | 0 | 0.811098 | 0 | 0 | 0 | 0 | -2.449100 |
| <i>v</i> _x (2-4) | 0.747178 | 0.271156 | 0.606794 | 0 | 0 | 0 | -0.701384 | -0.384063 | 0.600463 | 0.600463 | 10.716499 |
| <i>v</i> _y (2-4) | 0.210488 | -0.962535 | 0.170940 | 0 | 0 | 0 | -0.291751 | 0.923307 | 0.249771 | 0.249771 | 2.486134 |
| <i>v</i> _z (2-4) | -0.630412 | 0 | 0.776260 | 0 | 0 | 0 | 0.650340 | 0.759643 | 0.759643 | 0.759643 | -8.676855 |
| <i>v</i> _x (3-4) | 0 | 0 | 0 | 0.778902 | 0.278949 | -0.561693 | 0 | 0 | 0.600463 | 0.600463 | 6.947096 |
| <i>v</i> _y (3-4) | 0 | 0 | 0 | 0.226255 | -0.960306 | -0.163160 | -0.291751 | 0.923307 | 0.249771 | 0.249771 | 2.176371 |
| <i>v</i> _z (3-4) | 0 | 0 | 0 | -0.584910 | 0 | -0.811098 | 0.650340 | 0 | 0.759643 | 0.759643 | -6.227755 |

Tab. 6. Normal matrix **a^T · P · a** in begin iteration of the Gauss-Newton procedure

| a^T · P · a (matrix columns multiplied by differences of unknown coordinates) | | | | | | | | | | |
|------------------------------------------------------------------------------------------------|------------------------|------------------------|------------------------|------------------------|------------------------|------------------------|------------------------|------------------------|------------------------|------------------------|
| <i>db</i> ₂ | <i>dl</i> ₂ | <i>dh</i> ₂ | <i>db</i> ₃ | <i>dl</i> ₃ | <i>dh</i> ₃ | <i>db</i> ₄ | <i>dl</i> ₄ | <i>dh</i> ₄ | <i>dl</i> ₄ | <i>dh</i> ₄ |
| 3.00000E+4 | 0 | 0 | -9.98337E+3 | -6.29236E+1 | -5.72982E+2 | -9.95451E+3 | -9.26186E+2 | 2.23381E+2 | -9.26186E+2 | 2.23381E+2 |
| 0 | 3.00000E+4 | 0 | 6.57476E+1 | -9.99967E+3 | -4.74128E+1 | 9.06359E+2 | -9.92857E+3 | -7.75945E+2 | -9.92857E+3 | -7.75945E+2 |
| 0 | 0 | 3.00000E+4 | 5.72665E+2 | 5.11012E+1 | -9.98346E+3 | -2.93652E+2 | 7.52169E+2 | -9.96735E+3 | 7.52169E+2 | -9.96735E+3 |
| -9.98337E+3 | 6.57476E+1 | 5.72665E+2 | 3.00000E+4 | 0 | 0 | 0 | 0 | 7.98906E+2 | 0 | 7.98906E+2 |
| -6.29236E+1 | -9.99967E+3 | 5.11012E+1 | 5.72665E+2 | 3.00000E+4 | 0 | 0 | 0 | -9.93791E+3 | -9.93791E+3 | -9.93791E+3 |
| -5.72982E+2 | -4.74128E+1 | -9.98346E+3 | -9.98346E+3 | 0 | 3.00000E+4 | 0 | 0 | 8.45193E+2 | 8.45193E+2 | 8.45193E+2 |
| -9.95451E+3 | 9.06359E+2 | -2.93652E+2 | -2.93652E+2 | 0 | 0 | 3.00000E+4 | 0 | -8.59245E+2 | -8.59245E+2 | -8.59245E+2 |
| -9.26186E+2 | -9.92857E+3 | 7.52169E+2 | -9.92857E+3 | -9.93791E+3 | -9.93791E+3 | -9.93791E+3 | 6.50782E+2 | 0 | 6.50782E+2 | 0 |
| 2.23381E+2 | -7.75945E+2 | -9.96735E+3 | 7.98906E+2 | -7.23579E+2 | -9.94174E+3 | -9.94174E+3 | 0 | 3.00000E+4 | 3.00000E+4 | 3.00000E+4 |

Tab. 7. The components of the vector $a^T \cdot P \cdot W$ in the each iteration of the Gauss-Newton procedure

| Elements of the vector $a^T \cdot P \cdot W$ in iterations: | | | |
|-------------------------------------------------------------|----------------|----------------|----------------|
| i | 1 | 2 | 3 |
| 1 | 1.6864553E+05 | -1.0969105E+01 | 8.9149308E-04 |
| 2 | -1.2324487E+05 | 1.2123575E+01 | -6.7426009E-04 |
| 3 | -8.2113291E+03 | 7.6216302E-01 | -4.9565343E-05 |
| 4 | -7.8977780E+03 | -1.0134767E+01 | 1.0786275E-03 |
| 5 | -1.5229785E+05 | -1.2157631E+01 | 1.3372504E-03 |
| 6 | 8.1341696E+03 | -4.1223950E-01 | 2.6142379E-05 |
| 7 | -3.7657707E+05 | 3.4604647E+01 | -2.9547127E-03 |
| 8 | -1.7894077E+05 | 2.5758809E+01 | -2.4728577E-03 |
| 9 | -2.9343510E+03 | -1.4216646E+00 | 4.2518101E-05 |

Tab. 8. The Gauss-Newton procedure in the method I: unknown corrections in subsequent iterations

| ITERATION | ID-POINT | db [m] | dL [m] | dh [m] | dB ["] | dL ["] |
|-----------|----------|---------|---------|---------|------------|------------|
| 1 | 2 | 1.5614 | 13.5613 | 0.1899 | 0.0505289 | 0.6942714 |
| | 3 | 5.8974 | 14.3237 | 0.1620 | 0.1907362 | 0.7902022 |
| | 4 | 14.2154 | 15.4151 | 0.7421 | 0.4601356 | 0.7650612 |
| 2 | 2 | -0.0001 | -0.0009 | 0.0000 | -0.0000038 | -0.0000441 |
| | 3 | -0.0001 | -0.0003 | 0.0000 | -0.0000044 | -0.0000142 |
| | 4 | -0.0012 | -0.0012 | 0.0000 | -0.0000390 | -0.0000614 |
| 3 | 2 | 0.0000 | 0.0000 | 0.0000 | 0.0000000 | 0.0000000 |
| | 3 | 0.0000 | 0.0000 | -0.0000 | 0.0000000 | 0.0000000 |
| | 4 | 0.0000 | 0.0000 | 0.0000 | 0.0000000 | 0.0000000 |

Tab. 9. Comparison of the convergence of the Gauss-Newton procedure in three methods using the vector norm of unknown differences in length of arcs.

| Absolute maximal coordinate corrections in subsequent iterations [m] | | | |
|----------------------------------------------------------------------|--------------------|---------|---------|
| Iteration | Index of the metod | | |
| | I | II | III |
| 1 | 15.4151 | 15.4138 | 14.8418 |
| 2 | 0.0012 | 0.0001 | 0.6752 |
| 3 | 0.0000 | 0.0000 | 0.0208 |
| 4 | | 0.0000 | 0.0006 |
| 5 | | | 0.0000 |
| 6 | | | 0.0000 |

Comments:
 I – original GNSS – vectors ($\Delta X, \Delta Y, \Delta Z$)
 II – differences of geodetic coordinates ($\Delta B, \Delta L$)
 III – geodesic parameters (s, α)

7. Conclusion and remarks

Converting the Cartesian GNSS vectors to geometric elements of the reference ellipsoid, such as the differences in geodetic coordinates or the lengths and azimuths of geodesics, are popular in computer applications, relating to the adjustment of a combined (hybrid) geodetic network in the geodetic (ellipsoidal) coordinate system. Unfortunately, as it can be seen from the analysis conducted in Section 2.2, such a procedure is risky in terms of systematic errors, which may go significantly beyond the level of stochastic observation errors. The maximum size of the systematic errors measured by the lengths of the arcs on the ellipsoid, depends on the error of determining the position vector in Cartesian space (measured with the length of the vector displacement Δ) and also depends on the same vector length (approximately on the length s of the arc on the ellipsoid). The maximum impact determines the value of the expression $\delta = \Delta \cdot \eta$, where $\eta = s / R_s$, R_s – the approximate radius of the spherical Earth. For example, if $\Delta = 1$, then for the result precision $\delta < 0.001$ should be in approximate estimation: $s < 6.5$ km. In practice, by connecting the network to reference stations, we will have to deal with lengths measured in tens and even hundreds of kilometers. This makes it necessary to increase the accuracy of the approximate coordinates, which are the anchor points of the GNSS vectors before their projection on the ellipsoid. Then, we usually use the point coordinates of the network adjusted at some initial stage.

While adjusting the combined network on the ellipsoid we do not need to transform the GNSS vectors to pseudo-observations. We can totally eliminate the problem of described systematic errors by creating the observation equations in the ellipsoidal frame for the original GNSS vectors. The coefficients and the free components of the appropriate linearized equations are expressed explicitly by the known formulas (cf. description in Section 3). The method was tested on the example of a network of 4 points – ASG-EUPOS stations and the results were compared with those of alternative algorithms. For this purpose the GeoNet system programs and their special modifications were used. In each case, we have the solution of the non-linear least squares problem using the iterative method (Gauss-Newton procedure). Results with descriptions are given in Section 6.

Acknowledgements

The work has been elaborated under the statutory research “Optimization of engineering measurements for civil engineering needs” in Department of Geodesy and Geotechnics at Rzeszów University of Technology, No U-544/DS, 2014–2015.

Literature

- Adam, J., Halmos, F. and Varga M. (1982). On the concepts of combination of Doppler Satellite and Terrestrial Geodetic Networks. *Acta Geodaet., Geophys. et Montanist. Acad. Sci. Hung.* Vol. 17(2).
- Baeumker, M. (1984). *Zur dreidimensionalen Ausgleichung von terrestrischen und Satellitenbeobachtungen*. Wiss. Arbeiten der Fachrichtung Verm. d. Universität Hannover, 130.
- Czarnecki, K. (1994). *Geodezja współczesna w zarysie*. Wydawnictwo Wiedza i Życie, ISBN 83-86805-67-6. Warszawa 1994.
- Daxinger, W. and Stirling, R. (1995). Kombinierte Ausgleichung von terrestrischen und GPS – Messungen. *Osterreichische Zeitschrift für Vermessung und Geoinformation*, 83, 48–55.
- Deutsch R. (1965): *Estimation Theory*. Prentice-Hall, Inc. Englewood Cliffs, N.J.
- Gajderowicz, I. (1979). Łączne wyrównanie sieci dopplerowskich i naziemnych. Z.N. ART w Olsztynie. *Geodezja i Urządzenia Rolne*, 8.
- Gajderowicz, I. (1981). A theoretical basis for simultaneous adjustment of Doppler and terrestrial networks using a satellite reference ellipsoid. *Artificial Satellites*, 16(1).
- Gajderowicz, I. (1997). *Combination of classical observations with two-dimensional GPS vectors*. Olsztyn University of Agriculture & Technology. Institute of Geodesy.
- Gargula, T. (2010). GPS vector Network adjustment on the projection plane of local coordinate system. *Polska Akademia Nauk, Oddział w Krakowie, Komisja Technicznej Infrastruktury Wsi*. Nr 6/2010, 133–144
- Groten, E. (1977). *Combination of geometrical satellite with terrestrial data*. In (Eds. Halmos F. and Samogyi J.): Optimization of design and computation of control networks – International Symposium in Sopron, 4–10 July, 1977). Akademiai Kiado, Budapest, 95–104.
- Hofmann-Wellenhof, B., Lichtenegger, H. and Wasle E. (2008). *GNSS Global Navigation Satellite Systems*. Springer-Verlag Wien.
- Kadaj, R. (1997). Wyrównanie sieci wektorowej GPS i jej transformacja do układu odwzorowawczego elipsoidy Krasowskiego lub GRS-80 w programach systemu GEONET. Seminarium Komitetu Geodezji PAN: Zastosowanie technik kosmicznych w geodezji i geodynamice. Kraków 22–23 września 1997.
- Kadaj, R. (1998). *Models, methods and computation algorithms of kinematic network in geodetic deformations measurements*. [In Polish: *Modele, metody i algorytmy obliczeniowe sieci kinematycznych w geodezyjnych pomiarach przemieszczeń i odkształceń obiektów*]. Wydawnictwa AR w Krakowie, 1988, ISBN 83-86524-37-5.
- Kadaj R. (2008). New algorithms of GPS post-processing for multiple baseline models and analogies to classic geodetic networks. *Geodesy and Cartography*, Vol. 57, No 2, 61–79
- Krakiwsky, E.,J. and Thomson, D.B. (1974). Mathematical models for the combination of terrestrial and satellite Networks. *The Canadian Surveyor*, 28(5).
- Mołodeńskij, M.S. (1954). Nowyj mietod reszenija geodeziczeskich zadacz (ros). *Trudy CNIIGAiK*, 103, Moskwa 1954.
- Leick, A. (2004). *GPS Satellite Surveying*. John Wiley & Sonst, Inc. (Third Edition). ISBN 0-471-05930-7.
- Strauss, R. and Walter, H. (1993). Die Ausgleichung von GPS-Beobachtungen im System der Landeskoordinaten. *AVN* 6/1993, 207–212
- Strehle, J. (1996). Ermittlung von Landeskoordinaten aus GPS-Messungen. *Mitteilungsblatt DVW-Bayern* 41/1996, 623–645
- Szpunar, W. (1982). *Fundamental of higher geodesy*. [In Polish: *Podstawy geodezji wyższej*], PPWK-Warszawa 1982.
- Świątek, K. (1986). Wyrównanie łączne sieci naziemnej i doplerowskiej. *Geodezja i Kartografia*, XXXV, 3–4.
- Świątek, K. (1988). Wyrównanie sieci geodezyjnych z wykorzystaniem pomiarów doplerowskich i analiza modeli transformacji. *Acta Acad. Agricult. Ac.Technicae Olstenensis. Supplementum A*. No. 17.

- Thomson, D.B. (1976). *Combination of Geodetic Networks*. Technical Report No. 30, April 1976, Department of Surveying Engineering University of New Brunswick, Canada
- Warchałowski, E. (1952). *Higher geodesy – mathematical part*. [In Polish: *Geodezja Wyższa – część matematyczna*] PWN – Warszawa 1952.
- Welsch, W.M. and Oswald, W. (1984). *Kombinierte Ausgleichung von Doppler-Satellitenetzen und terrestrischen Netzen*. In: Schödlbauer, A., Welsch, W. (Hrsg.) : *Satelliten-Doppler-Messungen Beiträge zum Geodätischen Seminar 24/25. September 1984*. Schriftenreihe des Wissenschaftlichen Studiengangs Vermessungswesen der Hochschule der Bundeswehr München, Heft 15, S. 155–191
ISSN: 0173-1009

