

MODELING AND SIMULATION OF A TRACKED MOBILE INSPECTION ROBOT IN MATLAB AND V-REP SOFTWARE

Submitted: 16th December 2016; accepted: 18th February 2017

Michał Ciszewski, Łukasz Mitka, Tomasz Buratowski, Mariusz Giergiel

DOI: 10.14313/JAMRIS_2-2017/11

Abstract:

This paper presents modeling and simulation of a tracked mobile robot for pipe inspection with usage of MATLAB and V-REP software. Mechanical structure of the robot is described with focus on pedipulators, used to change pose of track drive modules to adapt to different pipe sizes and shapes. Modeling of the pedipulators is shown with application of MATLAB environment. The models are verified using V-REP and MATLAB co-simulations. Finally, operation of a prototype is shown on a test rig. The robot utilizes joint space trajectories, computed with usage of the mathematical models of the pedipulators.

Keywords: tracked robot, pipe inspection, kinematics, robot adaptation, V-REP, MATLAB, co-simulation

1. Introduction

In this paper, modeling and simulation of a pipe inspection mobile robot are presented. The work is focused on a motion unit of the robot that can adapt to various shapes and dimensions of pipelines. To realize motion of the robot, modeling and calculations are performed in MATLAB software and simulations are run in MATLAB, connected to V-REP robotic simulator. To validate the simulations, prototype testing in an analogous environment is shown. V-REP (Virtual Robot Experimental Platform) is a general-purpose robot simulation framework, widely used in robotics [4]. It is rich with functions, features and comprehensive APIs for interfacing with virtually any application or device. The most important attribute that affects functionality of the simulator is a distributed architecture, this means each simulation element can be controlled in different ways. These ways include regular Application Programming Interface (API) with available programming languages: Lua, C/C++; remote API with available languages: Lua, C/C++, Python, Java, MATLAB/Octave and Urbi or Robot Operating System (ROS) interface which can advertise or subscribe to ROS topics and offer ROS services.

Latest research in the field of pipe inspection robots has been made by some teams. Hansen et. al. proposed a wheeled mobile robot intended for inspection and pipe mapping [8]. Their robot is designed for movement in horizontal pipes and utilizes a forward facing, fisheye camera. This setup allows to perform visual odometry and build pipe models with high

resolution. Nayak and Pradhan proposed a robot for horizontal and vertical pipes. It is designed to operate in pipes with constant radius [12]. Its construction allows to use only one actuator to pass through pipeline elbows. Sharma *et al.* proposed an inspection robot with additional functionality, which is obstacles removal and pipe cleaning [13]. They have also tested a possibility of controlling the robot wirelessly. Another approach was presented by ULC company [14]. They designed a robot, called Micro Magnetic Crawler, capable of inspecting any object made of steel. This compact robot uses magnetic attraction, thus can move in any direction, even upside down, on ferromagnetic surfaces. A manually adjustable robot chassis for variable pipe geometry was designed by Inuktun company [9]. The Versatrax robot can be set for motion inside of pipes of various diameters or can move on horizontal surfaces.

The research shows that an automatic adaptation of the robot's motion unit to the pipe shape and diameter has not been investigated by research teams. In this paper, an automatic adaptation system is shown in the context of modeling, simulation and prototype validation.

2. Mechanical Structure

The mechanical structure of the robot is based on two pedipulators that control pose of the track drive

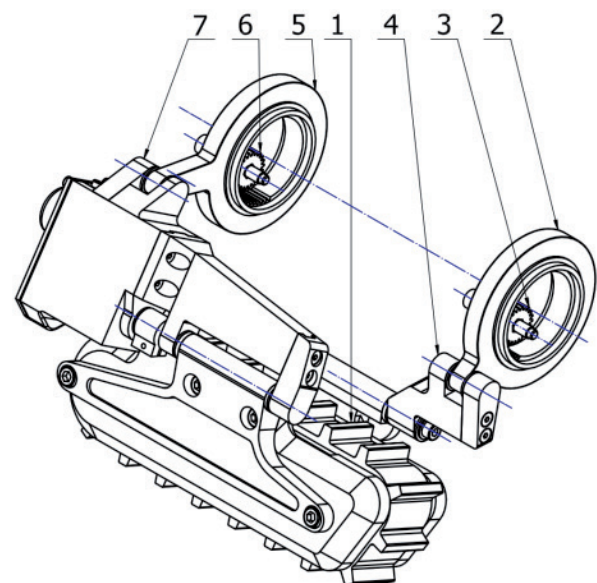

Fig. 1. Pedipulator mechanism [7]: 1 – track drive module; 2 – front driven ring; 5 – rear driven ring; 3, 6 – sprockets; 4 – front arm; 7 – rear driven arm

modules. One pedipulator consists of two coaxial, independently driven rings (2, 5), with axes of rotation in the center of the robot body, as depicted in Fig. 1. These rings are driven by servomotors and torques are transferred by internal meshing gear transmissions (3, 6). Arms (4, 7) are mounted to the rings by revolute joints. Other sides of the arms are attached to the track drive module (1). The rear arm (7) is equipped with an additional servomotor.

By assembling two pedipulators to the robot body, a reconfigurable drive mechanism was constructed that allows positioning of the track drives to allow robot adaptation to various environments [2]. The robot is equipped with six servomotors, responsible for setting pose of the track drive modules, thus the robot has 8 drives in total. Construction of the robot guarantees that it can operate in pipelines with active water flow, sewage pipes and other environments where watertightness and dust protection is required.

3. Kinematic Model of the Pedipulator

Kinematic modeling of the robot was divided into two main parts. The first objective was to create a model of the robot motion on flat and inclined surfaces. This model was described in [3]. The model, however, does not provide information on the adaptation of the robot's motion unit to the environment, since motion is described for only one pedipulator pose, dedicated for even surfaces. To complement the modeling approach, a mathematical model of the pedipulators that set pose of the track drive modules was created.

In general, the pedipulator structure for adaptation of one track module is a closed kinematic chain that consists of five links and six revolute joints, among which three are actuated. Their angles of rotations are denoted by and in Fig. 2. The mecha-

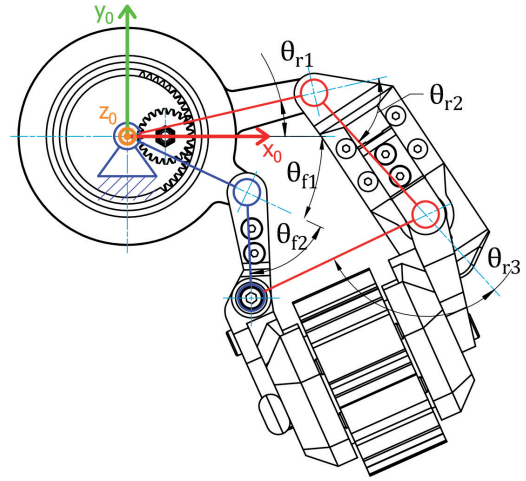

Fig. 2. Kinematic model of pedipulator: θ_{r1} – rear ring (5) rotation angle; θ_{f1} – front ring (2) rotation angle; θ_{r3} – rear arm (7) rotation angle with respect to track drive module (1); θ_{r2}, θ_{f2} – unactuated joints rotation angles

nism can be treated as planar, since all the revolute joints axes are parallel. In order to apply an approach widely used in robotics for open kinematic chains, the mechanism was divided into two planar manipulators with two and three degrees of freedom that represent front and rear parts of the pedipulator. Later, it was assumed that the manipulators have to maintain position of their end-effectors in one point, that would fulfil constraints of the closed kinematic chain.

For both manipulators, transformation matrices were created, using standard Denavit-Hartenberg notation [11]. The transformation from end-effector to the base coordinate system for the front (2-DOF) manipulator is presented by equations (1) and (2), and for the rear (3DOF) manipulator by equations (3) and (4).

$$T_{2,0}^F = Rot_{z,\theta_{f1}^{var}} Trans_{x,a_{f1}} Rot_{z,\theta_{f2}^{var}} Trans_{x,a_{f2}} \tag{1}$$

$$T_{2,0}^F = \begin{bmatrix} \cos(\theta_{f1} + \theta_{f2}) & -\sin(\theta_{f1} + \theta_{f2}) & 0 & a_{f2} \cos(\theta_{f1} + \theta_{f2}) + \cos(\theta_{f1}) a_{f1} \\ \sin(\theta_{f1} + \theta_{f2}) & \cos(\theta_{f1} + \theta_{f2}) & 0 & a_{f2} \sin(\theta_{f1} + \theta_{f2}) + \sin(\theta_{f1}) a_{f1} \\ 0 & 0 & 1 & 0 \\ 0 & 0 & 0 & 1 \end{bmatrix} \tag{2}$$

where: θ_{f1}, θ_{f2} – rotation angles of joints 1, 2; a_{f1}, a_{f2} – lengths of links 1, 2.

$$T_{3,0}^R = Rot_{z,\theta_{r1}^{var}} Trans_{x,a_{r1}} Rot_{z,\theta_{r2}^{var}} Trans_{x,a_{r2}} Rot_{z,\theta_{r3}^{var}} Trans_{x,a_{r3}} \tag{3}$$

$$T_{3,0}^R = \begin{bmatrix} \cos(\theta_{r1} + \theta_{r2} + \theta_{r3}) & -\sin(\theta_{r1} + \theta_{r2} + \theta_{r3}) & 0 & a_{r3} \cos(\theta_{r1} + \theta_{r2} + \theta_{r3}) + a_{r2} \cos(\theta_{r1} + \theta_{r2}) + \cos(\theta_{r1}) a_{r1} \\ \sin(\theta_{r1} + \theta_{r2} + \theta_{r3}) & \cos(\theta_{r1} + \theta_{r2} + \theta_{r3}) & 0 & a_{r3} \sin(\theta_{r1} + \theta_{r2} + \theta_{r3}) + a_{r2} \sin(\theta_{r1} + \theta_{r2}) + \sin(\theta_{r1}) a_{r1} \\ 0 & 0 & 1 & 0 \\ 0 & 0 & 0 & 1 \end{bmatrix} \tag{4}$$

where: $\theta_{r1}, \theta_{r2}, \theta_{r3}$ – rotation angles of joints 1, 2, 3; a_{r1}, a_{r2}, a_{r3} – lengths of links 1, 2, 3.

$$J^F = \begin{bmatrix} -a_{f2} \sin(\theta_{f1} + \theta_{f2}) - \sin(\theta_{f1}) a_{f1} & -a_{f2} \sin(\theta_{f1} + \theta_{f2}) \\ a_{f2} \cos(\theta_{f1} + \theta_{f2}) + \cos(\theta_{f1}) a_{f1} & a_{f2} \cos(\theta_{f1} + \theta_{f2}) \\ 0 & 0 \\ 0 & 0 \\ 0 & 0 \\ 1 & 1 \end{bmatrix} \quad (5)$$

$$J^R = \begin{bmatrix} -a_{r3} \sin(\theta_{r1} + \theta_{r2} + \theta_{r3}) - a_{r2} \sin(\theta_{r1} + \theta_{r2}) - \sin(\theta_{r1}) a_{r1} \\ a_{r3} \cos(\theta_{r1} + \theta_{r2} + \theta_{r3}) + a_{r2} \cos(\theta_{r1} + \theta_{r2}) + \cos(\theta_{r1}) a_{r1} \\ 0 \\ 0 \\ 0 \\ 1 \end{bmatrix} \quad (6)$$

$$\begin{bmatrix} -a_{r3} \sin(\theta_{r1} + \theta_{r2} + \theta_{r3}) - a_{r2} \sin(\theta_{r1} + \theta_{r2}) & -a_{r3} \sin(\theta_{r1} + \theta_{r2} + \theta_{r3}) \\ a_{r3} \cos(\theta_{r1} + \theta_{r2} + \theta_{r3}) + a_{r2} \cos(\theta_{r1} + \theta_{r2}) & a_{r3} \cos(\theta_{r1} + \theta_{r2} + \theta_{r3}) \\ 0 & 0 \\ 0 & 0 \\ 0 & 0 \\ 1 & 1 \end{bmatrix}$$

Poses of the pedipulators for particular pipe sizes were determined with usage of the CAD model. With usage of the data, joint angular positions were used as input for initial and final poses for trajectory genera-

tion. The second step was to generate 5th order polynomial trajectories for the front (2-DOF) manipulator between initial and final poses. Next, inverse kinematics problem was solved with usage of a numerical approach, based on the Jacobian pseudo-inverse for the rear (3-DOF) manipulator to match position of end-effector of the front manipulator. In this case, analytical formulation of the inverse kinematics problem gives 8 solutions for the entire pedipulator structure. Therefore, additional conditions were used for planar manipulators, as in [11]. Joint rotation ranges were also limited, to comply with the mechanical structure. Finally, oscillations of the manipulator, caused by transitions through singular positions were eliminated. The calculations were done in MATLAB software with Robotics Toolbox [5]. Thus, smooth trajectories for transformation of the robot pedipulators were obtained to realize required motion in the workspace. Original construction of the pedipulator as a closed kinematics chain ensures that it is sufficient to use three motors to set desired pose of the track drive module. Rotation angles of the positioning drives during transformations are shown in Fig. 3.

Initial validation of the model was performed in MATLAB. The pedipulators positions were drawn for every step of the trajectory. In Fig. 4, the kinematic model of both pedipulators is depicted during transformation from neutral pose (all servomotors are in the middle of their operating range) to the pose that allows the robot to move in horizontal pipes with internal diameter of Ø210 mm. The MATLAB visualization of the pedipulators model shown in Fig. 4 proves that the trajectory calculation algorithm is properly designed for reconfiguration of the robot chassis. The analyzed closed kinematic chain is highly dependent on the path taken to attain desired pose, thus it is not always possible to use arbitrary start pose and expect satisfactory kinematics results for every goal pose.

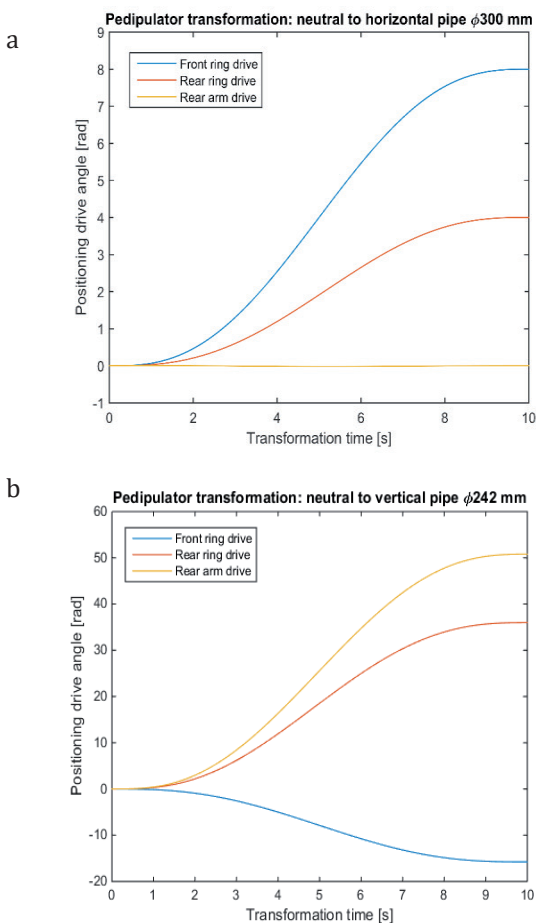

Fig. 3. Pedipulator transformation – joint trajectories:
a – neutral pose to horizontal pipe φ300 mm,
b – neutral pose to vertical pipe φ242 mm

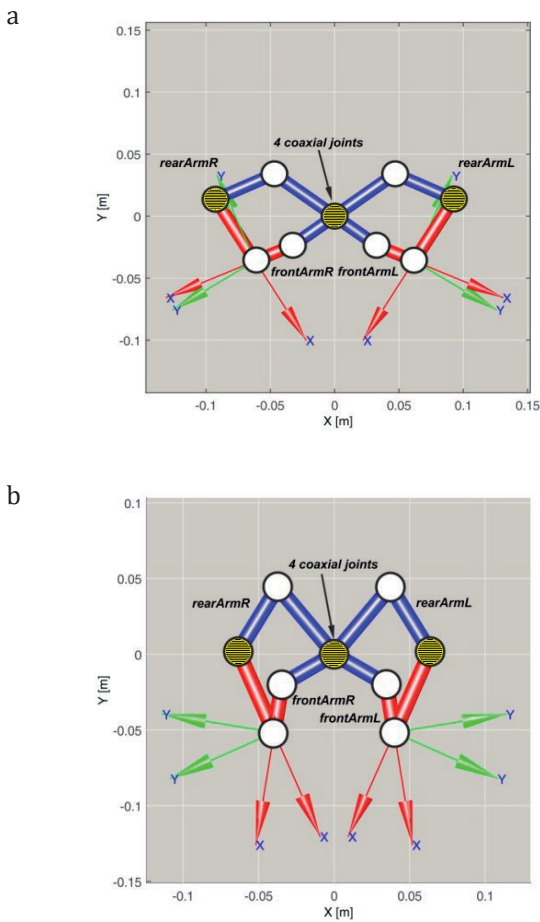

Fig. 4. Kinematic model of two assembled pedipulators during transformation (white color – free joints, hatched – actuated joints): a – neutral pose, b – pose for motion in vertical pipe with diameter φ 242 mm

3. Robot Motion Simulations in V-REP and MATLAB software

In order to validate the mathematical model and trajectory calculations of the robot’s pedipulators, it was necessary to use a simulation environment. As previously stated, V-REP is a versatile and customizable simulation platform that can be easily connected with remote applications such as MATLAB and may be used for various applications [10].

Due to the fact that the robot control algorithms, presented in this paper are developed in MATLAB, a remote API was used. Remote APIs, independently of programming language chosen, offer four operation modes, designed for different tasks (Fig. 5). First mode is a blocking function call that causes an API client to wait for response of the simulator. The second type is a non-blocking function call that could be used only for sending data to the simulator, as it does not wait for a server response. The third type is data streaming, where a client sends message once and a server sends reply regularly to the client. The last mode is synchronous operation that enables synchronization of each simulation step with API client. In this mode, server holds execution of each simulation step, until a trigger from client is sent, thus it is usually the slowest mode of communication.

The first step of the simulation procedure was to create a properly defined robot model in V-REP that satisfies all mechanical constraints and can be simulated in a way resembling real operation. The robot model designed in Autodesk Inventor software was imported in the V-REP environment. Next, the model structure was defined in a way that allows creation of joints, motors and ensures interaction with environment. To improve calculation efficiency, the model was composed of visible bodies and dynamically enabled bodies that were simplified using convex hull decomposition. Overview of the robot model is presented in Fig. 6. To improve visual aspects of the simulation, the tracks were modeled using separate segments that move on a predefined path (Fig. 6a). In contrast, for dynamic model, each track was represented by five cylinders with rounded external surfaces that provide steady contact with flat and curved pipe surfaces, whilst assuring simulation results analogous to a tracked drive. This setup proved to be the most reliable for various simulation cases. Natural representation of a track as a set of segments is computationally costly and may lead to simulation instabilities due to rapidly alternating contact points of the track treads. The pedipulator mechanisms were modeled using bodies connected by rotary joints that were set as actuated with position controllers, or not actuated, according to the mechanical design.

The robot model created in V-REP was linked with MATLAB using a remote API link. The link allows running simulations directly from MATLAB, with simultaneous data transfer between both programs. The mathematical model created in MATLAB was used to control positions of the servomotors to realize pedipulator transformation trajectories and also for velocity control of the track drive modules of the robot 3D model created in V-REP.

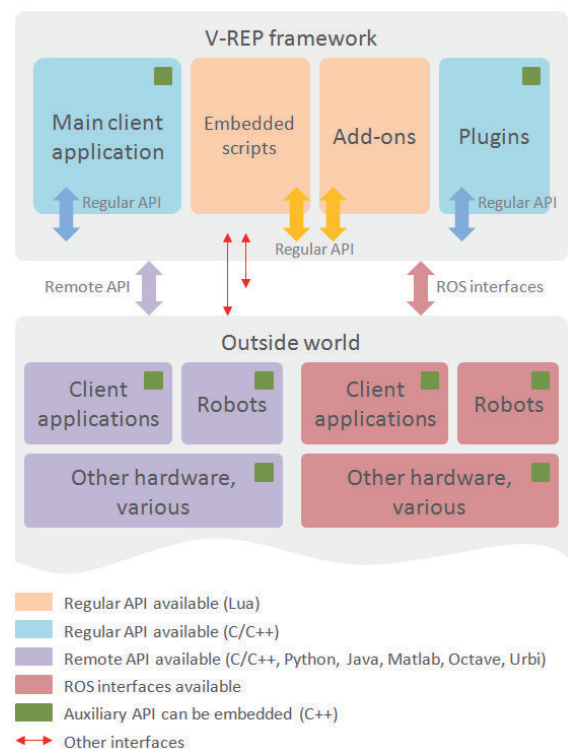

Fig. 5. V-REP API overview [4]

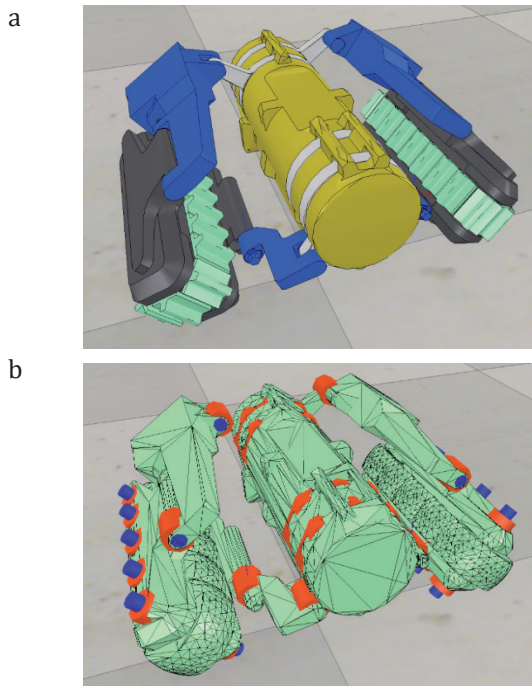

Fig. 6. V-REP model of pipe inspection robot: a – visible bodies, b – dynamically enabled bodies (light color) with joints (dark color)

Initially, reconfiguration of the pedipulators was verified by V-REP simulations of the robot model placed on a dedicated support that provided unobstructed motion of the track drive modules. Next the robot motion was tested in various environments, such as flat surfaces and pipes with circular cross-section. In order to check operation of the robot in complex pipe structures, a dedicated V-REP scene was prepared (Fig. 7a). The test run contained the following pipe segments: straight $\phi 300$ mm, 90° bend in $\phi 300$ mm pipe (Fig. 7b), followed by straight segment, reducer from $\phi 300$ mm to $\phi 242$ mm, straight $\phi 242$ mm segment followed by 30° bend (Fig. 7c) and straight section.

A co-simulation of MATLAB and V-REP was prepared to check if the robot would be able to traverse the pipe run. Reconfiguration of the pedipulators was performed automatically based on the mathematical model and motion of the robot in pipe was realized by manual control, with usage of a joystick connected to a MATLAB/Simulink model. In Fig. 7b, the robot V-REP model is presented during motion in 90° bend in $\phi 300$ mm pipe. At this stage of control system design, operation of passing bends was performed with usage of teleoperation with visual feedback.

In Fig. 8 we can observe the robot during simulation in a pipe reducer between $\phi 300$ mm and $\phi 242$ mm pipes. This process is realized automatically, with track velocity adapted to pedipulators reconfiguration process. With this approach, servomotors overload is avoided, that could arise from rapid transfer through the reducer by excessive velocity, manually set with teleoperated control. The usage of MATLAB and V-REP co-simulation run in synchronous mode allowed to control the robot 3D model in a similar way as a real prototype, because application of mathematical models was tested and verified visually.

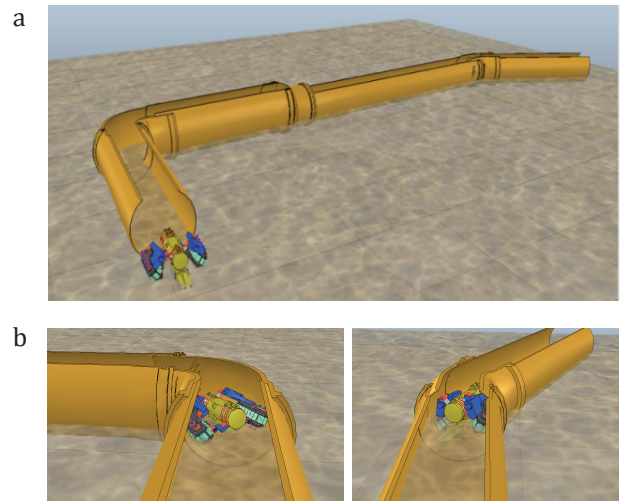

Fig. 7. V-REP model of pipe inspection robot: a – pipe run, b – robot driving through pipe elbows in DN315 and DN250 pipes

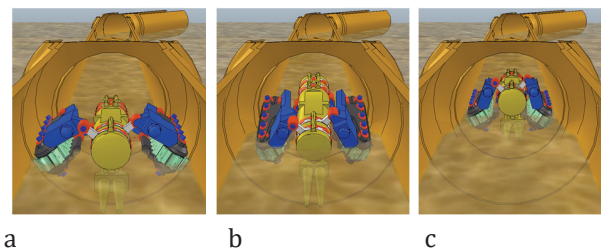

Fig. 8. V-REP model of pipe inspection robot during re-configuration in the reducer of DN315 pipe to DN250 pipe: a – robot in pipe DN315, b – robot in the reducer, c – robot after reconfiguration to pipe DN250

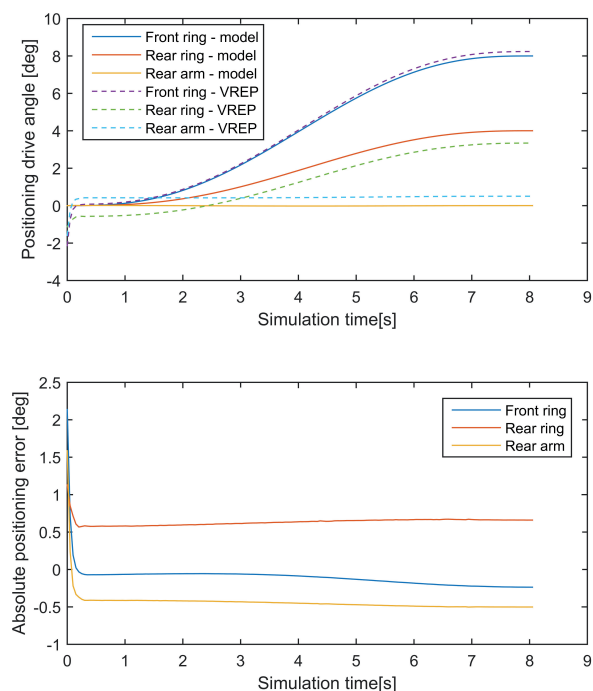

Fig. 9. V-REP and MATLAB simulation results comparison for transformation from neutral position to pipe $\phi 300$ mm: a – positioning drives angles, b – absolute positioning error V-REP vs MATLAB

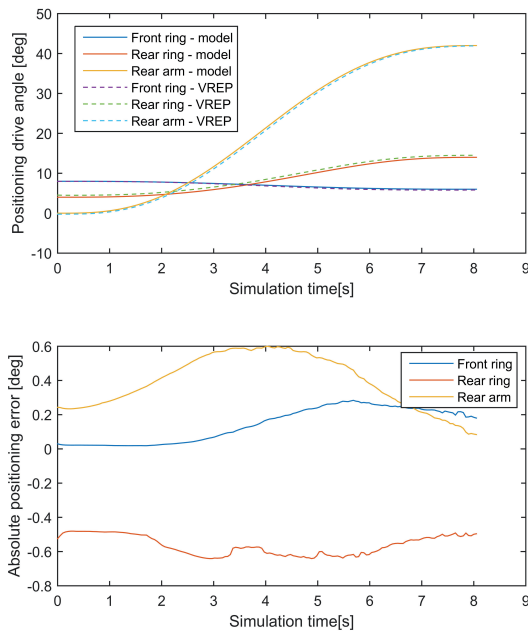

Fig. 10. V-REP and MATLAB simulation results comparison for transformation from pipe $\text{Ø}300$ mm to pipe $\text{Ø}242$ mm: *a* – positioning drives angles, *b* – absolute positioning error V-REP vs MATLAB

Results of the simulations are presented in Fig. 9 and Fig. 10. We can see that the mathematical model trajectories from MATLAB and simulation results from V-REP coincide well and the absolute positioning errors of pedipulators drives do not exceed 0.6° for the analyzed cases. The errors are caused mainly by joint position tolerances of the Bullet dynamics engine, used for the simulation, especially when closed kinematic chain is analyzed. This errors are satisfactory and do not affect proper transformation of the pedipulators between desired poses.

V-REP and MATLAB co-simulations proved to be very efficient testing tools for motion analysis of the robot models that allowed optimization of pedipulators transformation trajectory calculation algorithm and development of control system for the robot prototype.

4. Tests of the Prototype

For the testing of the robot's ability to adapt its pedipulators poses and assessment of prototype mobility inside pipes, a test rig was prepared. It consisted of straight pipes of nominal diameter DN315 mm and DN250 mm, pipe reducer connecting two pipes and two bends, one 90° bend of diameter DN315 mm and second 30° bend in pipe of diameter DN250. The pipe segments were assembled as presented in Fig. 11a, similarly to the simulation scene presented in Fig. 7.

The objective of the test procedure was to verify if the robot would be able to traverse the rig. Initially, motion unit of the prototype was reconfigured to the pose for motion in DN315 mm pipe, with usage of the trajectories for positioning servomotors, computed in MATLAB. Next, the robot was placed at the entry of the pipeline. Control strategy of the robot included

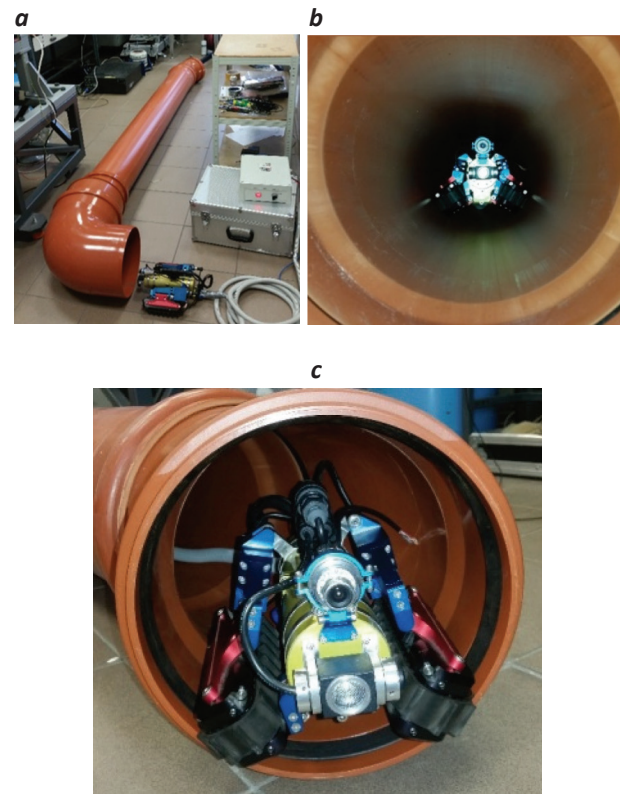

Fig. 11. Tests of the prototype: *a* – test rig, *b* – the robot in DN250 pipe ($\text{Ø}242$ mm internal diameter), *c* – the robot after completion of the test run

manual operation of track drives by velocity setting and automatic transformation of the robot's pedipulators. Motion in the test rig included the following steps: drive into the pipe, traverse 90° bend in larger pipe, get to pipe narrowing, reconfigure motion unit to smaller pipe diameter, get into smaller pipe (Fig. 11b), pass to next bend, traverse 30° bend in smaller pipe, get out of the test rig. The performed test complied with simulation results and the robot completed the experiment successfully (Fig. 11c).

In straight pipe segments, motion of the robot without slip was observed, however negotiation of pipe bends implied excessive slip of track drives that were controlled manually. Application of an automatic velocity control during negotiation of bends would provide smoother transitions. The most difficult operation was to drive through pipe reducer from DN315 mm to DN250 mm. In this case, simultaneous reconfiguration of the robot's pedipulators and the tracks forward motion would be optimal, but the functionality was not available in the current version of control system of the prototype.

5. Conclusions and Future Work

In this paper, mathematical modeling, simulations and tests of a pipe inspection robot with an adaptable motion unit were shown. Co-simulation prepared in VREP simulation software with MATLAB/Simulink computation environment proved to be very efficient tools for testing control system design for the inspection mobile robot, featuring two pedipulators with closed kinematic chains. The pedipulators transfor-

mation trajectories, generated with usage of mathematical models, were also verified using a prototype on a dedicated test rig analogous to simulation environment. The preliminary prototype tests allowed validation of the pedipulators reconfiguration but did not include verification of a complete control system for robot motion.

Future work would focus on software implementation for the inspection robot, including a vision system that would serve as an aid for autonomous reconfiguration inside pipelines, depending on the recognized geometry. Moreover, the robot would be simulated during motion and adaptation in vertical pipes. An upgraded electronic board and enhanced software would allow control of the track drive clamp forces exerted by pedipulators extension during motion of the robot inside of vertical pipelines.

AUTHORS

Michał Ciszewski* – Department of Robotics and Mechatronics, AGH University of Science and Technology, Cracow, Poland. E-mail: mcisz@agh.edu.pl

Łukasz Mitka – Department of Robotics and Mechatronics, AGH University of Science and Technology, Cracow, Poland. E-mail: mitka@agh.edu.pl

Tomasz Buratowski – Faculty of Mechanical Engineering and Robotics AGH University of Science and Technology, Poland. E-mail: tburatow@agh.edu.pl

Mariusz Giergiel – Faculty of Mechanical Engineering and Robotics, AGH University of Science and Technology, Poland. E-mail: giergiel@agh.edu.pl

*Corresponding author

REFERENCES

- [1] S.R.S. Buss, *Introduction to inverse kinematics with jacobian transpose, pseudoinverse and damped least squares methods*, Univ. California, San Diego, Typeset Manuscr, vol. 132, 2009, 1–19. DOI: 10.1016/j.neuroscience.2005.01.020.
- [2] M. Ciszewski, T. Buratowski, M. Giergiel, P. Malika, K. Kurc, “Virtual Prototyping, Design and Analysis of an in-Pipe Inspection Mobile Robot”, *J. Theor. Appl. Mech.*, vol. 52, 2014, 417–429.
- [3] M. Ciszewski, M. Waclawski, T. Buratowski, M. Giergiel, K. Kurc, “Design, Modelling and Laboratory Testing of a Pipe Inspection Robot”, *Arch. Mech. Eng.*, vol. 62, 2015, 395–408. DOI: 10.1515/meceng-2015-0023.
- [4] P. Corke, Robotics, *Vision and Control: Fundamental Algorithms in MATLAB*, Springer, 2011, ISBN 978-3-642-20144-8 DOI: 10.1007/978-3-642-20144-8
- [5] I. Duleba, M. Opałka, “A comparison of Jacobian-based methods of inverse kinematics for serial robot manipulators”, *Int. J. Appl. Math. Comput. Sci.*, vol. 23, 2013, 373–382. DOI: 10.2478/amcs-2013-0028.

- [6] J. Giergiel, M. Giergiel, T. Buratowski, M. Ciszewski, „Pedipulator’s mechanism for positioning of a track drive module, esp. for mobile robots”, Patent application (description of the invention) no. PL 406656, 2015 (in Polish).
- [7] P. Hansen, H. Alismail, P. Rander, B. Browning, “Visual mapping for natural gas pipe inspection”, *Int. J. Rob. Res.*, vol. 34, 2015, 532–558. DOI: 10.1177/0278364914550133.
- [8] J. Khalilov, A.T. Kutay, “Interfacing Matlab/Simulink with V – REP for A Controller Design for Quadrotor”, *Int. J. Eng. Res. Rev.*, no. 3, 2015, 42–49.
- [9] K. Kozłowski, P. Dutkiewicz, W. Wróblewski, *Modelowanie i sterowanie robotów* (Control and modelling of robots), 1st ed., PWN: Warszawa, 2012. (in Polish)
- [10] A. Nayak, S.K. Pradhan, “Design of a new in-pipe inspection robot”, *Procedia Eng.*, no. 97, 2014, 2081–2091. DOI: 10.1016/j.proeng.2014.12.451.
- [11] Y. Sharma, K. Deepak, P. Kumar, A. Chauhan, “Blockage removal and RF controlled pipe inspection robot (BRICR)”, *Int. J. Electron. Telecommun.*, vol. 4, 2015, 62–68.
- [12] Coppelia Robotics, V-REP Virtual Robot Experimental Platform, 2016, <http://www.coppeliarobotics.com>
- [13] Inuktun, Inuktun crawler vehicles, 2015, <http://www.inuktun.com/crawler-vehicles>
- [14] ULC, ULC’S Micro-magnetic crawler, 2014, <http://ulcrobotics.com>