

Methods for acquiring data on terrain geomorphology, course geometry and kinematics of competitors' runs in alpine skiing: a historical review

WŁODZIMIERZ S. ERDMANN^{1*}, VASSILIS GIOVANIS², PIOTR ASCHENBRENNER¹,
VAIOS KIRIAKIS², ANDRZEJ SUCHANOWSKI³

¹ Śniadecki University of Physical Education and Sport, Gdańsk, Poland.

² National and Kapodistrian University of Athens, Athens, Greece.

³ Rusiecki Olsztyn Higher School, Olsztyn, Poland.

Purpose: This paper aims at the description and comparison of methods of topographic analysis of racing courses at all disciplines of alpine skiing sports for the purposes of obtaining: terrain geomorphology (snowless and with snow), course geometry, and competitors' runs. *Methods:* The review presents specific methods and instruments according to the order of their historical appearance as follows: (1) azimuth method with the use of a compass, tape and goniometer instruments; (2) optical method with geodetic theodolite, laser and photocells; (3) triangulation method with the aid of a tape and goniometer; (4) image method with the use of video cameras; (5) differential global positioning system and carrier phase global positioning system methods. *Results:* Described methods were used at homologation procedure, at training sessions, during competitions of local level and during International Ski Federation World Championships or World Cups. Some methods were used together. *Conclusions:* In order to provide detailed data on course setting and skiers' running it is recommended to analyse course geometry and kinematics data of competitors' running for all important competitions.

Key words: alpine skiing, topographical methods, course geometry, competitors' running

1. Introduction

1.1. Difficulties of analysis in alpine skiing

In alpine ski racing there is a vast number of variables on which the performance of an athlete skier depends. In many sports, the successful analysis of movement is relatively easy. For example, in rowing, swimming and athletic sprints the movement is relatively rectilinear. At the same time, there are sports, such as shooting and weightlifting, where the athlete's body remains in the same position. Alpine ski motion is one of the most difficult to analyse because the trajectory is

curvilinear and the athlete is moving within a wide-open space. In alpine ski disciplines, the skier is moving down the slope with a motion relative to the start and finish planes, snow/ground (up and down body motion), and relative to the gates (left and right motion).

The analysis of alpine skiing takes into account the following three main topics: (1) terrain (slope) geomorphology: (a) free of snow for homologation, (b) with snow for competitions; (2) capturing course setting; (3) capturing skiers' biomechanics [11].

According to Gilgien et al. [13] a valid and practicable measurement system for capturing skiers' kinematics should: (1) fulfil high accuracy standards, (2) cause minimal interference with the athletes' skiing, (3) allow the largest possible capture volumes of training and competition.

* Corresponding author: Włodzimierz S. Erdmann, Śniadecki University of Physical Education and Sport, ul. K. Górskiego 1, 80-336 Gdańsk, Poland. Phone: 48 58 605304939, e-mail: werd@awf.gda.pl

Received: August 24th, 2015

Accepted for publication: March 14th, 2016

1.2. Terrain geomorphology

The International Ski Federation (FIS) requires data to be provided by the host of the ski event regarding slope (course) characteristics. This is necessary in order to obtain the homologation document. Unfortunately, within the FIS International Ski Competition Rules [19] the term *course* is used in two different meanings: (1) as a slope (or terrain) prepared for the competition or for warm up (e.g., rule no. 614.1.3, 650.1), also called a *race-course* (601.4.6.1), and (2) a set of gates prepared by the course setter (e.g., 603.3.1, 614.1.2).

The International Ski Federation [19] homologation procedure requires the preparation of (650.4.1): (a) a description of the course, including, among other items, the location of the start and finish lines according to sea level, vertical drop, surface length of the whole course, the average, maximum, and minimum gradients (in percentages); (b) a map with contour lines and course drawn on it; (c) a profile indicating vertical drop and length of the course; (d) a photograph on which the course is marked; (e) a sketch of the entire course with all details and data indicated, among others, steep sections, curves, trail intersections.

For downhill (DH) and super giant (SG) race courses must be re-homologated every 5 years, while slalom (SL) and giant slalom (GS) every 10 years. All race courses must be re-homologated whenever there

has been a major modification to the slope by natural event or by changes in man made features. Hand-held GNSS devices or references from a digital map (for example, ski area planning maps, Google Earth) are sufficiently accurate; engineering precision is not necessary [28].

The measurement process for ski course homologation usually takes place when the slope is free of snow. However, when considering the practical importance of homologation data, they are of limited importance for the coach and competitor since the snow can change the slope considerably. A considerable work performed Schiestl et al. [25], who captured and modelled the position of snow surface in a 3-dimensional object-space and then tracked ski trajectories on this snow surface. Also Gilgien et al. [12] and Reid et al. [24] surveyed a snow surface using theodolite.

1.3. Analysis of course setting

All training advice is aimed at enhancing the athletes' technique and tactics in order to be more effective in the next course of the competition or ski run. The length of the course, sometimes reaching about four kilometres in the downhill discipline, and the height difference between the start and the end gate limit the ability of an alpine ski coach or training team to capture the data.

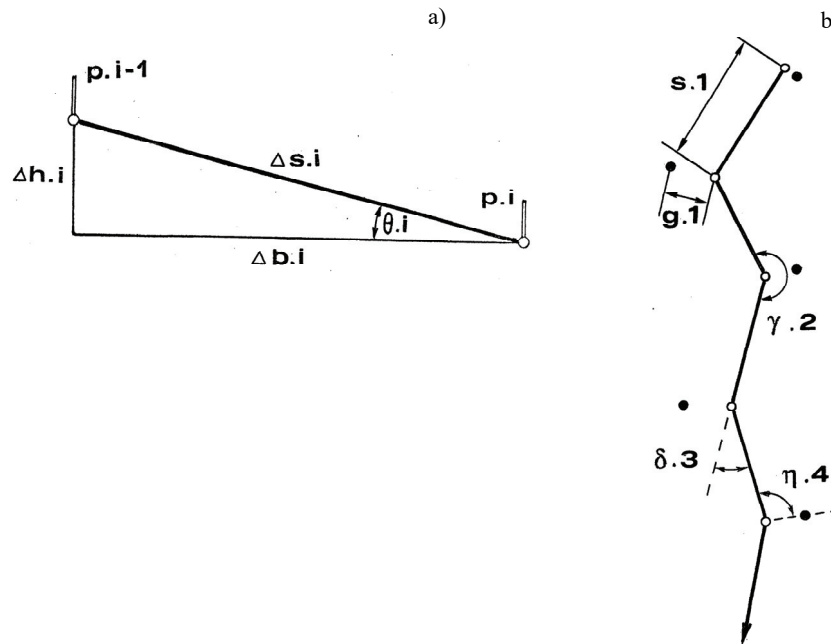

Fig. 1. Quantities needed to establish geometry of an alpine ski course: (a) p – pole of a gate, Δb – horizontal length of inter-gate distance, Δh – height of inter-gate distance, Δs – length of inter-gate distance on the oblique plane, θ – angle of inclination; (b) white circles – internal (curve) pole, black circle – external pole, g – breadth of a gate, δ – angle of deviation, η – angle between inter-gate distance and gate breadth, γ – external angle between two consecutive inter-gate distances [7]

In the 1990s, Erdmann presented a series of technical reports which described the theory of alpine ski course measurement. Figure 1 presents the variables needed for a description of an alpine ski course.

From 1993 and continuing for several years, the authors of this paper investigated the geometry of courses. The first investigations were devoted to giant slalom of Greek skiers (national championships) [7]. Then the giant slalom geometry of the best world skiers was investigated [1], [9]. In 2006–2007 all four alpine ski disciplines, namely slalom, giant slalom, super giant, and downhill during the FIS World Cups were investigated in Austria, Germany, Italy, Norway and Slovenia [6]. In addition Giovanis and Kiriakis [15] presented a paper on the topography of alpine ski courses. Up to the beginning of the 21st century other authors did not targeted their research work on collecting data on runs through the whole alpine ski course.

1.4. Analysis of biomechanics of skier's technique and tactics

Since the 1970s, researchers have made efforts to record kinematics and kinetic data for alpine ski racers. Some have investigated runs through just a few gates using video techniques to record skiers' runs, e.g., Broadfoot [2], the Cotelli brothers [4], and Nachbauer [22].

The authors of this article started to analyze skiers' runs from 1993 using two video cameras positioned along the course (all 35 gates were covered) [7]. Subsequently, several other investigations were accomplished devoted to the FIS World Cup in giant slalom [1], [9]. The above investigations represented a significant improvement on previous research since the investigations covered skiing along the whole course. This enabled an assessment of skiers' runs according to tactics, i.e., distribution of velocity along the whole course.

Reid et al. [24] analysed in 2009 two complete turns during a slalom race simulation on even, medium terrain (19°). The skier's 3-D positions were determined using a direct linear transformation (DLT) based method and 4 panning cameras working with a frequency of 50 Hz. Two hundred and eight control points were positioned so as to surround the two turns of interest, thereby creating a calibration volume of approximately $50 \times 10 \times 2$ m.

1.5. The aim of the study

Within contemporary sport there is a lot of technical equipment – for athletes, coaches, referees, ana-

lysts. Also in alpine skiing there are many devices necessary for the evaluation of skiers' training and competition runs, organization of competitions and media coverage.

The aim of this review study was a presentation of former (up to 2010) methods and instrumentation used during alpine ski research on slope geomorphology, course geometry and course runs. A further target is an assessment of the effectiveness of each research system, through the determination of topographical and biomechanical variables and usage by coaches, and also describing the accuracy of obtaining the given values.

The methods presented below are in order of historical appearance used by researchers:

- (1) azimuth method,
- (2) optical method,
- (3) triangulation method,
- (4) image-based method,
- (5) global navigation satellite system.

The authors of this article used all the above methods during their investigations.

2. Review of historic research methods

2.1. Research methods and purposes of their usage

Several methods can be used in order to achieve data on geomorphology of the slope, setting of gates of the course, and also on kinematics of the skier's run.

In order to obtain inter-gate distances a metric tape was used. A simple azimuth method with utilization of a compass was used for obtaining angles of deviation of the basic setting of the course line.

In optical method, a theodolite (before) and tachymeter (later, with laser device) were used for: (a) snow geomorphology description, (b) obtaining precise positioning of poles of the gates, (c) positioning of pass points for video based photogrammetry (3D kinematics reconstruction). Also laser equipment alone can be used to obtain inter-gate distances. Photocells with electronic timer are utilized for timing of alpine skiers' runs.

Triangulation method was used for the purpose of obtaining inter-gate distances and angles of deviations in order not to use a compass and to improve accuracy of data.

Video cameras are used usually for obtaining technique of running and for time data of a skier's

run. This method can be used also for obtaining inter-gate distances. Having values of the distance and of the time one can calculate velocity values. Cameras (panned, tilted, zoomed) are used also for reconstruction of inter-gate trajectory of a skier and later on as a reference method for comparison with methods based on satellite navigation.

Global navigation satellite system is used for positioning the poles of gates in a 3D space and also for obtaining detailed trajectory of a skier along the fragment or along the whole course.

2.2. Simple azimuth method

In 1994, during pilot investigations of Greek alpine skiers for obtaining inter-gate distances a simple metric tape was used, while for obtaining angles of deviation the azimuth method (using a compass) was

used [7]. The research work was performed at Arakhova (Greece), at Parnassos Mountain Ski Centre during a regional competition.

By pointing a compass from the turning pole of the lower gate to the turning pole of the upper gate one can read an azimuth, i.e., an angle between the inter-pole line and a line directed to the north (Fig. 2a). Then by pointing a moving arm of the goniometer from lower gate to upper gate one can read an inclination angle (Fig. 2b).

By plotting all the inter-gate lines through azimuth angles one can calculate the value of deviation angles δ . The procedure is shown in Fig. 2c.

2.3. Photo-optical method

For timing of alpine skiers' runs of the whole length of the course and for obtaining two or three

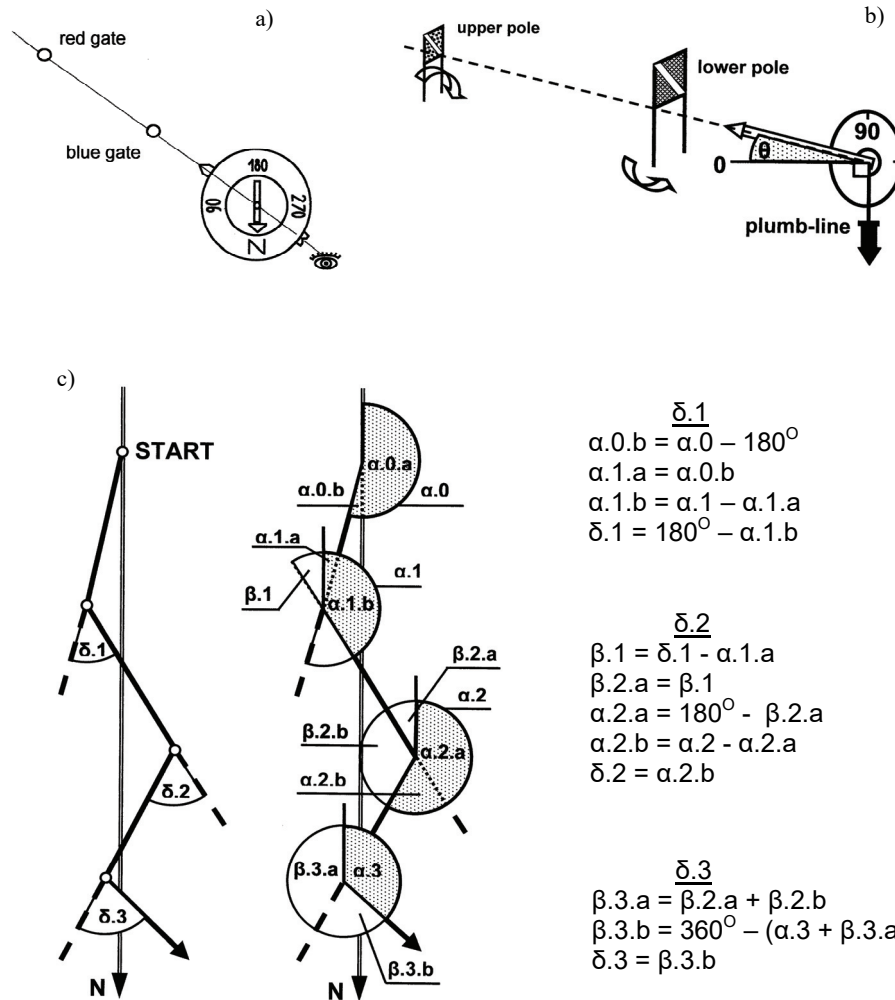

Fig. 2. Angle measurements: (a) azimuth angle (here: 120 degrees) obtained by aiming a compass' elements in the direction of lower pole of a blue gate and upper pole of a red gate with zero value established according to the North; (b) aiming with goniometer's ruler at two poles in order to establish angle of inclination; (c) example of procedure for obtaining angles of deviation δ from azimuth angles α

split times during training and during competitions photocells with electronic timer are utilized. The time measurement starts when a skier pushes a thin bar with his/her knees. Then, photocells situated along the

course measure the inter-mediate time data. The time measurement ends, also with the help of photocell equipment, when the skier's body part (usually hand or foot) crosses the finish line. During competitions

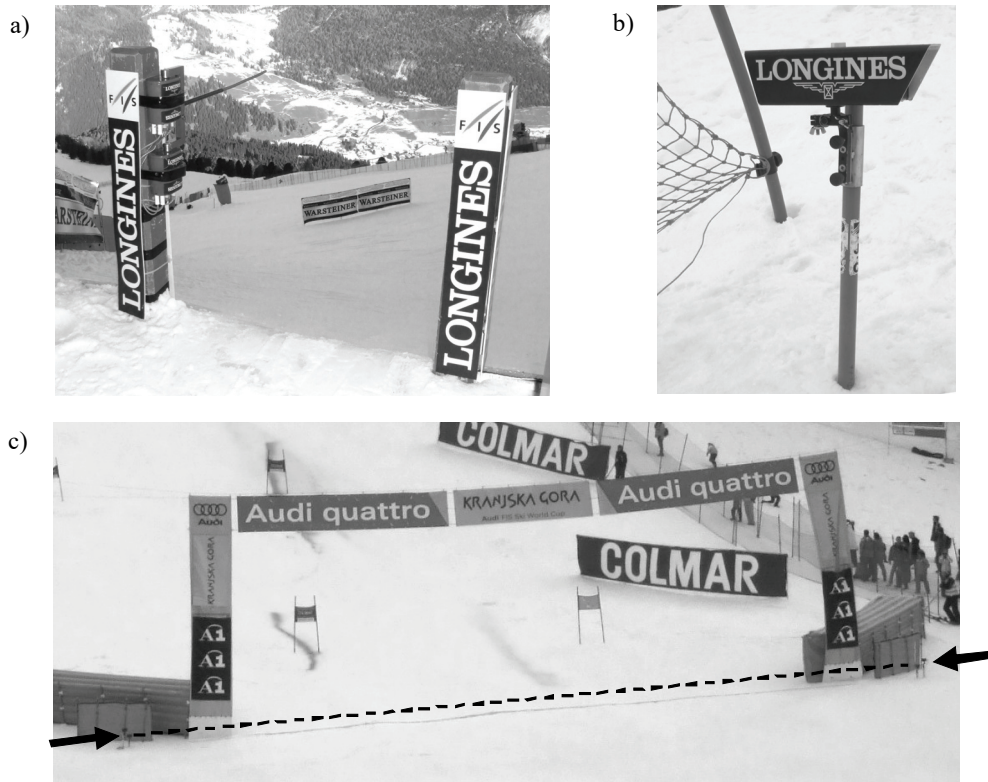

Fig. 3. A bar (a) and photo cells (b and c, shown with black arrows) situated at the start, along the course and at the finish line

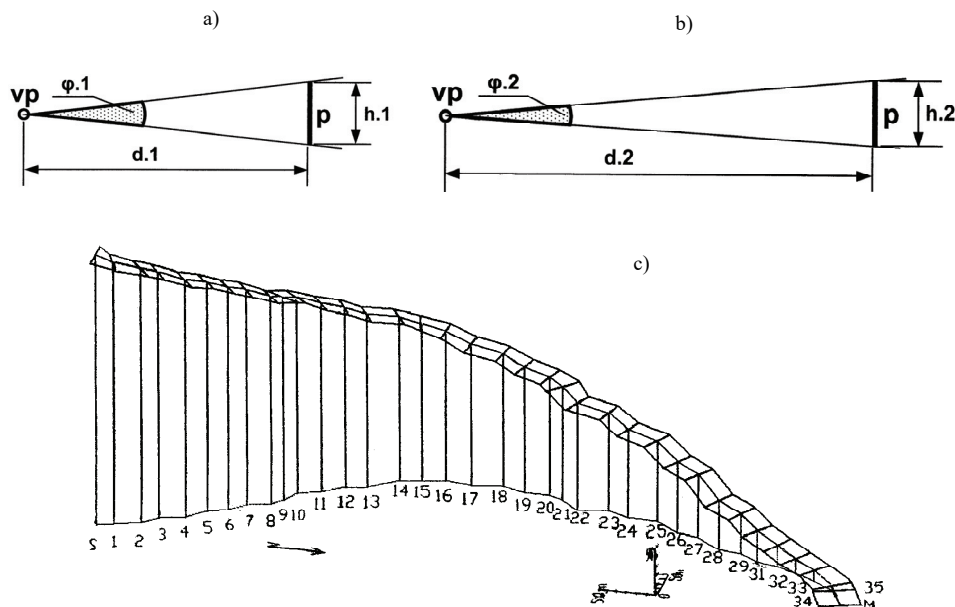

Fig. 4. The principle of function of theodolite: (a) object p seen from the shorter distance $d.1$; (b) object p seen from the longer distance $d.2$. With the same point of view vp and the same height h of an object ($h.1 = h.2$) its angle of viewing φ depends on the distance d from the point of view to the object.

The longer the distance, the smaller the angle of viewing;

(c) 3D of GS geometry of the track on the Tria-Pente Pigadia Mountain near Naoussa, Greece, obtained by theodolite method

approved by FIS, photocells are obligatory to measure competitors' run times (Fig. 3).

One of the variants of the optical method uses the principle that the angle of viewing an object depends on the distance from this object to the viewer. For many years, optical equipment has been used for this purpose, e.g., a geodetic theodolite. This instrument consists of a telescope mounted to swivel both horizontally and vertically. Before reading the data the theodolite should be accurately levelled. Crosshairs in the telescope permit accurate alignment with the object sighted. Mounted on a tripod, the theodolite is used to obtain a precise angular measurement of the positioning of poles at gates set on the alpine ski slope to form a competition course. From the same viewing point and with the same height of an object, its angle of viewing depends on the distance from the viewing point to the object. Figures 4a and 4b show the principle of a theodolite's function.

The theodolite was used by Erdmann and Giovanis in their investigations of giant slalom at the Greek Championships of Alpine Skiing in Naoussa [7]. The positioning of all GS gates was recorded. For every gate both turning poles and closing poles were positioned. The procedure for one setting of 35 gates plus start and finish gates took about 2 hrs. Figure 3c presents a 3-dimensional image of a GS course.

Alpine skiers of medium and high level choose the trajectory of movement closest to the inner (turning) poles of gates. This was the reason for omitting the positioning of the outer poles of the gates in the further investigations.

Pozzo et al. [23] investigated skiers' runs at the World Cup Giant Slalom in Val Badia in 2002. They made a video recording of runs through three gates in the middle section of the race. The 3-D mapping of the control points was obtained by means of a geodetic theodolite. In scientific approach of Reid et al. [24] both the control points and the snow surface were geodetically surveyed using theodolite.

2.4. Triangulation method

The triangulation method was introduced by the authors during the FIS World Cup competition in Kranjska Gora (Slovenia) and Saalbach Hinterglemm (Austria) in 1998 [1], [9]. The concept was based on the use of a tape only and a goniometer with a plumb-line. In this case, a tape was used to measure the distances between poles of adjacent inter-gate distances and distances between every second pole (Figs. 5a and b). Also an inclination angle was measured between two

poles – upper and lower of every inter-gate distance. Based on the above surface measurements of inter-gate (inter-pole) distances all surface angles (Fig. 5c) were calculated with the aid of the Carnot theorem (equation of cosines) (1)–(3)

$$a^2 = b^2 + c^2 - 2bc \times \cos \alpha, \quad (1)$$

$$b^2 = a^2 + c^2 - 2ac \times \cos \beta, \quad (2)$$

$$\zeta = 180^\circ - \alpha - \beta, \quad (3)$$

where α, β, ζ – angles of a triangle; a, b, c – sides of a triangle.

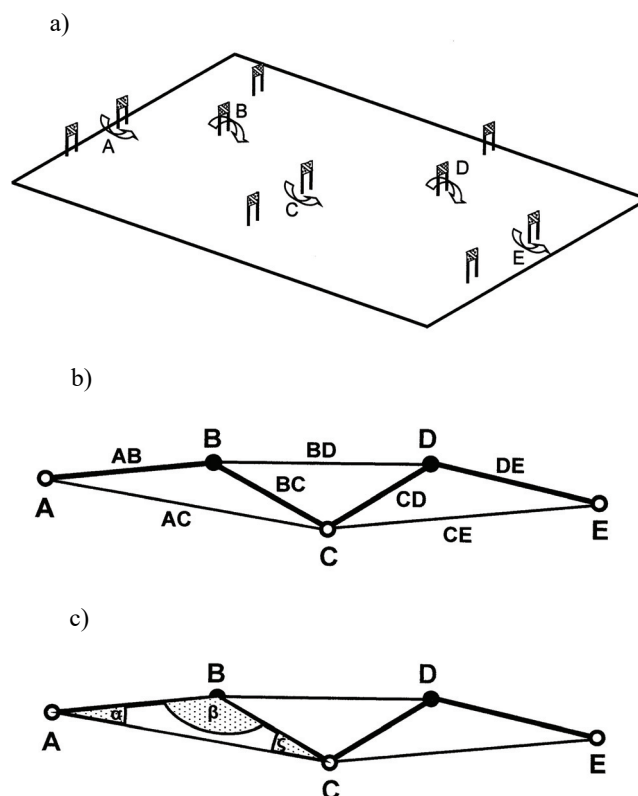

Fig. 5. Triangulation method: (a) fragment of alpine ski giant slalom with gates and turns shown near poles from A to E; (b) measurements of length of triangle's sides in triangulation method (the sides were measured in the following order: AB, AC, BC, BD, CD, CE and so on); (c) triangle angles α, β and ζ were calculated according to Carnot theorem from equations (1)–(3)

Figure 6 shows an example of the geometry of the FIS Alpine Ski World Cup course obtained in Saalbach.

Schiestl et al. [26] presented a method to reconstruct the trajectory of a skier from motion picture taken by a single camera. A mesh describing the snow surface was generated by triangulation of the terrain points.

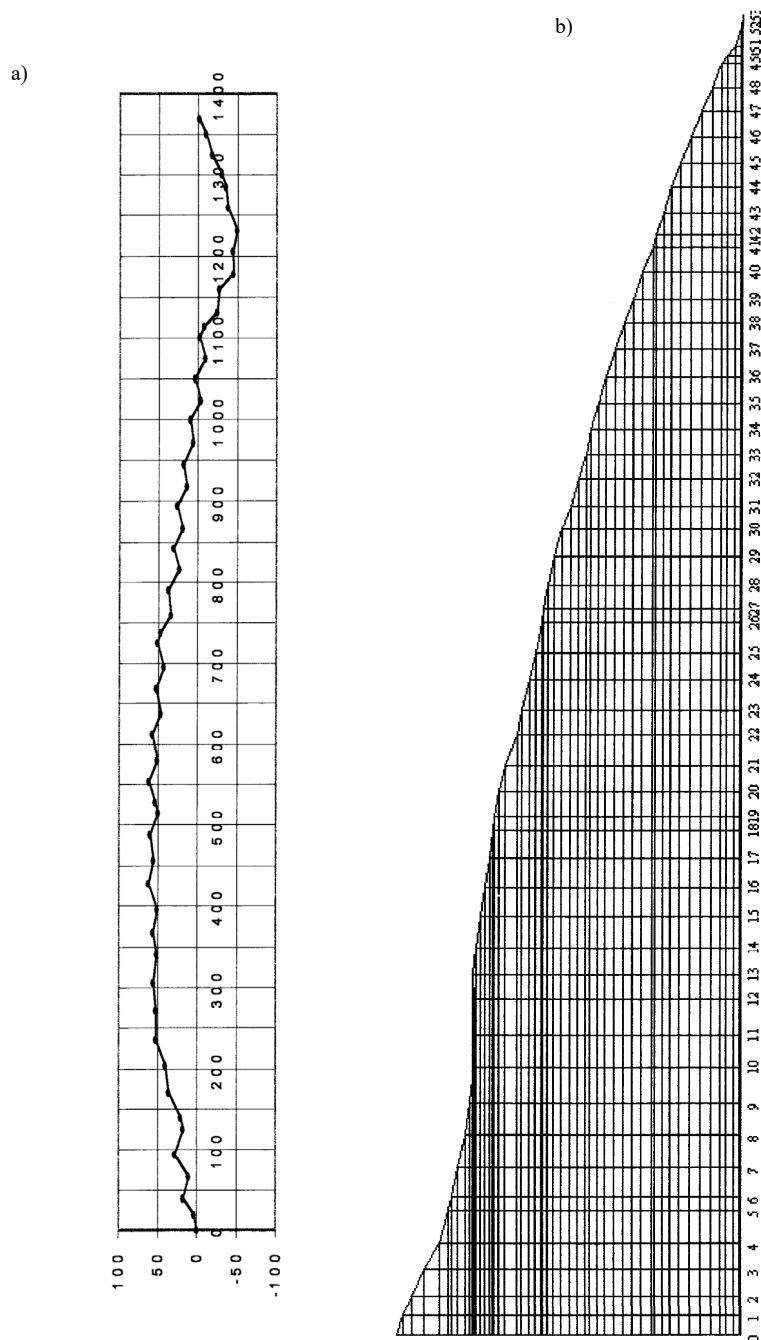

Fig. 6. Views of planar pictures: (a) on a surface of the course, (b) side elongated profile, of the FIS Alpine Ski World Cup course in Saalbach in 1998, second leg

2.5. Image based methods

Historically, the image based method was used in alpine skiing by several authors. Watanabe [29] described such investigations of skiers kinematics and kinetics starting as early as 1970. Later on, Broadfoot in 1979 [2], Nachbauer in 1987 [22] and others used 16 mm film camera to track the position of a skier for obtaining information on run techniques. Glenn and

Larsson [16] conducted a 2-dimensional analysis of a single giant slalom turn using multiple photographs taken at 7 Hz. Authors of these investigations used cameras for investigating a skier's run through a small section of the course, i.e., just through two to three gates.

Erdmann and Giovanis in 1994 [7] used video camera for investigating tactics of skier's movement at first for 10 gates section and then for the entire giant slalom course.

The video method was used also by the authors in Kranjska Gora (SLO) in 1998 for obtaining all inter-gate distance during the FIS Alpine Ski World Cup. For a singular inter-gate distance, a measurement camera was positioned at the centre of a circle which encompassed three apexes of a triangle. This triangle was formed by two inter-gate distances and a third

distance which is between two side apexes [9], [10] (Fig. 7).

Since at that time the quality of an analog video picture was not so good (as it is now with digital high definition technology, HD), the authors abandoned the image method. Thin poles were poorly visible from a long distance. Also the alpine course was sometimes

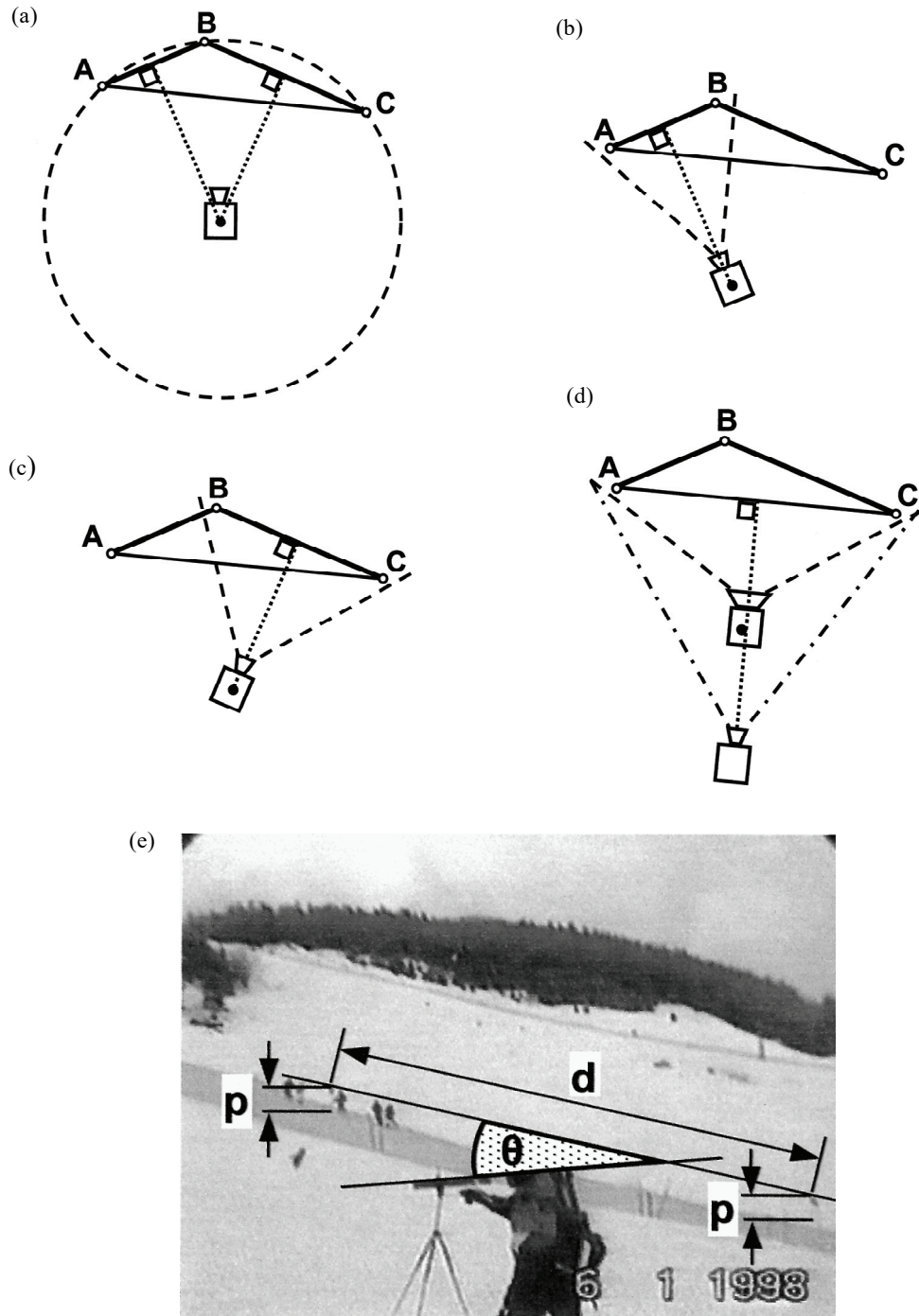

Fig. 7. Image method: (a) positioning of a camera in the centre of a circle which encompasses three apexes of a triangle (the centre was found at the crossing of bisections of triangle's sides); (b) camera is facing perpendicular upper inter-gate distance, (c) camera is facing perpendicular lower inter-gate distance; (d) camera is facing perpendicular distance between side apexes (camera can be set further to that distance equipped with normal lens or closer to that distance equipped with wide-angle lens); (e) picture from the camera's view-finder (p – poles, d – distance between poles, θ – angle to horizontal level)

difficult to see from a distance because of obstacles, e.g., trees.

The first reported 3-dimensional studies of alpine skiing were conducted at the end of the 1980s by Goodwin [17]. He used two 100 Hz synchronized cameras placed near the competition course for obtaining kinematics during the middle portion of a single turn in a slalom.

Detailed description of obtaining movement data in alpine skiing using pan and tilt cameras with zoom lenses were presented by Mössner et al. [20]. The authors used direct linear transformation (DLT) method for three-dimensional reconstruction of skier's movement on the slope. The authors computed values for each frame of each camera separately. For this purpose they used control points distributed on the slope. Their coordinates were determined by geodetic surveying. At least six points are needed to be visible in each frame but more points reduce the reconstruction error considerably. Under optimal conditions the mean errors are less than 5 cm in each coordinate. This approach is work consuming – a large number of control points in the object-space should be placed and then this requires a large digitization work volume.

To reduce the aforementioned both parts of the research process Drenk [5] used his approach (Passpoint method) based on the concept of determining the DLT parameters as functions of camera pan and tilt angles. To obtain this specialized camera tripods are required that precisely control movement angles of the camera.

Supej et al. [27] used at the slalom event 4 camcorders covering 2 kinematics subspaces at 50 Hz and at the giant slalom event 6 camcorders covering 3 kinematics subspaces at 25 Hz in order to analyze 3D kinematics values of 17-point body model of competitive alpine skiers.

2.6. Global navigation satellite system

Between 1989 and 1994 a system of 24 satellites was developed forming a GPS network working 24 hours across the whole surface of the Earth and near the Earth. The first GPS system was intentionally degraded (“Selective Availability”). But in 2000 this degradation was turned off. Currently four Global Navigation Satellite Systems operate, namely GPS, GLONASS (Russian Federation), Galileo (European Union – not yet in full operation), and BeiDou2 or COMPASS (China – not yet in full operation).

In general, the GNSS receiver is composed of an antenna, tuned to the frequencies transmitted by the satellites (usually two frequencies: L1 and L2), a receiver-

processor, and a highly stable clock (often a crystal oscillator). A GNSS receiver calculates its position (pseudo-range) by precisely timing the signals sent by GNSS satellites. Signals from at least three satellites for planar location and from at least four satellites for spatial location are needed. The position is given in latitude and longitude data. The elevation data (altitude) is also included. Many GNSS units show derived information such as direction and speed, calculated from position changes in time.

One of the most significant error sources is the GNSS receiver's clock. Because of the very high value of the speed of light, c , the estimated distances from the GNSS receiver to the satellites are very sensitive to errors in the GNSS receiver clock. One solution to this problem is receiving signals from more than four satellites. On a flat surface with the one system operating there was the possibility of receiving data from up to 12 satellites.

Satellite signals can be distorted on the way between the satellite and receiver. In order to avoid these errors the differential global positioning system, or DGPS, was introduced. Here one receiver is stationary. It serves as a reference station. It registers all distortions in the signal. The second receiver is mobile. All data received and stored by the mobile receiver are corrected according to data stored by the stationary receiver.

In just a few years, the technology of the GPS receiver has changed significantly. At the beginning of the 21st century GPS receivers had dimensions of about $16 \times 5 \times 3$ cm, mass of 270 grams, and worked with a frequency of 0.5 Hz [18].

Static measurements

The authors made investigations with the use of DGPS for all four alpine disciplines: DH, SG, GS, SL. Every discipline was investigated three times, with both legs for GS and SL. This was accomplished during the FIS Alpine Ski World Cup. Locations of the gates along the whole course were obtained. During the same competitions skiers' runs were recorded by a single camera aimed at the screen located at the finish area. There a picture of a skier was shown together with the run time from TV cameras placed along the whole course. In this way velocity of all skiers between all gates was obtained and their tactics of running was assessed [6].

Kinematic measurements

Brodie et al. [3] investigated alpine skiers using, among other instruments, GNSS equipment. They

used GPS receivers, one base station and one rover with 1 Hz output. Unfortunately, the accuracy of this system was weak, ± 5 to 10 m.

3. Discussion and conclusions

The top concern of alpine skiing is the problem of safety associated with the competitors' speed, where velocities reach a value exceeding 30 m/s (about 120 km/h). In order to protect skiers from accidents it is valuable to obtain data on how the course was set and how skiers run the course [8], [14], [21].

The present review concerned with the recording of both sections and the whole course, and comparison of the methods regarding the geomorphology of the terrain, geometry of a course, and skiers' run for alpine ski events. The review of the relevant literature for each method showed that the selection of the optimum method was affected by the following factors: (1) the available instruments used for the measurements; (2) the precision of the instruments – depends on the available equipment and the aim of measurements; (3) the location of the measurement – training site, competition course; (4) the number of runs and the number of gates in the race; (5) the athletes tested – special subjects, forerunners, competitors; (6) the type of video recording – multi-camera recording of the skier, one-camera recording of a screen located at the finish area showing a skier's run; (7) the measurement procedure and subsequent analysis.

For investigation of the geomorphology of the slope the best methods are tachymeter and DGNS performed with many measurement points. This takes into account both ground that is free of snow and covered with snow. For obtaining accurate locations of gate poles tachymeter and DGNS should also be used. For less accurate location the azimuth method, triangulation method, and hand held GNSS instruments are suitable.

The most approachable topographical method and corresponding instrument for a ski coach is the azimuth method. The next accessible method is the triangulation method. For both aforementioned methods the support of an optical method (laser equipment) is valuable. Other methods, such as the theodolite/tachymeter method and differential GPS need not only equipment of a higher price but also knowledge of how to use the instruments. Here a coach should be trained in how to use the instruments or he or she needs to hire specialists to do the measurements.

Using the measurement results the competition organizers and the researchers were able to present: (a) the geometric parameters of the slope both snowless and with snow cover, (b) the geometric parameters of the course set-up, (c) wrong set-up of sections of the course, (d) the biomechanical variables of the competitors during the race, (e) wrong distribution of effort of the competitors along the race.

The organizers of each alpine ski race should implement the required measurements of the gate locations in order to eliminate errors in gate set-up and to facilitate the collection of valuable data required for analysis of the kinematics of racing skiers.

References

- [1] ASCHENBRENNER P., *Kinematics of competitors' running on the course of alpine skiing giant slalom and its geometric parameters*, Doctoral dissertation, J. Śniadecki University of Physical Education, Gdańsk, 2002, (in Polish).
- [2] BROADFOOT R.C., *A biomechanical analysis of superior and interior alpine ski racers making a carved turn*, Master thesis, Springfield College, 1979.
- [3] BRODIE M., WALMSLEY A., PAGE W., *Fusion motion capture: a prototype system using inertial measurement units and GPS for the biomechanical analysis of ski racing*, *Sports Technol.*, 2008, 1(1), 17–28.
- [4] COTELLI F., COTELLI M., *Sci competizione. La tecnica delle tre discipline: slalom, gigante e discesa*, Longanesi & C., Milan 1979, (in Italian).
- [5] DRENK V., *Photogrammetric evaluation procedures for panning and tiltable cameras of variable focal length*, [in:] A. Barabás, G. Fábrián (eds.), *Proceedings of the 12th International Symposium on Biomechanics in Sports*, Budapest–Siófok, 1994, 27–30.
- [6] ERDMANN W.S., ASCHENBRENNER P., *Biomechanics of tactics of running a course in four alpine skiing disciplines: First course geometry results*, *Human Movement*, 2008, 9(2), 24–127.
- [7] ERDMANN W.S., GIOVANIS V., *Preliminary investigations of kinematics of a skier in giant slalom*, [in:] S. Mazurkiewicz (ed.), *Proceedings. All Polish Conference of Biomechanics*, B. Czech University of Physical Education, Kraków, 1995, 57–62, (in Polish).
- [8] ERDMANN W.S., GIOVANIS V., *Incidents in alpine skiing giant slalom*, [in:] H.J. Riehle, M.M. Vieten (eds.), *XVI Symposium of the International Symposium on Biomechanics in Sports*, Proceedings, University of Konstanz, Konstanz 1998, 311–312.
- [9] ERDMANN W.S., SUCHANOWSKI A., ASCHENBRENNER P., *Geometry and running of the alpine ski FIS World Cup Giant Slalom, Part One: Geometry*, [in:] Y. Hong, D.P. Johns (eds.), *Proceedings of XVIII International Symposium on Biomechanics in Sports*, Vol. II, The Chinese University of Hong Kong, Hong Kong (China), 2000, 637–641.
- [10] ERDMANN W.S., GIOVANIS V., SUCHANOWSKI A., ASCHENBRENNER P., *Geometry and running of the alpine ski FIS World Cup Giant Slalom, Part two: Velocity*, [in:] J.R. Blackwell (ed.), *XIX International Symposium on Biomechanics in Sports*, Works in Progress, University of San Francisco, San Francisco, Calif., 2001, 5.

- [11] GILGIEN M., *Characterization of skier's mechanics, course setting and terrain geomorphology in World Cup alpine skiing using Global Navigation Satellite System. Injury risk, performance and methodological aspects*, Doctoral dissertation, Norwegian School of Sport Sciences, 2014.
- [12] GILGIEN M., RIED R., HAUGEN P., SMITH G., *A method to capture and model the geomorphology of snow surfaces for use in biomechanical investigations in snow sports*, [in:] J. Cabri, F. Alves, D. Araújo, J. Barreiros, J. Diniz, A. Veloso (eds.), 13th Annual Congress of the European College of Sport Science, Universidade Técnica de Lisboa, Estoril, Portugal, 2008, 569.
- [13] GILGIEN M., SPÖRRI J., LIMPACH P., GEIGER A., MÜLLER E., *The effect of different global navigation satellite system methods on positioning accuracy in elite alpine skiing*. Sensors (Basel), 2014, 14(10), 18433–18453.
- [14] GIOVANIS V., *Kinematics of slalom courses' runs in alpine skiing and problem of injuries*, Doctoral dissertation, B. Czech University of Physical Education, Kraków 1998, (in Polish).
- [15] GIOVANIS V., KIRIAKIS V., *Recording of bodies of topography and their possibilities of application in the alpine ski*, Hellenic Journal of Physical Education & Sport, Thessaloniki 2007, Issue 63, 52 (O20).
- [16] GLENN B., LARSSON O., *Mechanics of a giant slalom turn*, The Professional skier, 1987, Winter, 3, 23–26.
- [17] GOODWIN D.A., *Alpine slalom ski racers*, [in:] J. Hamill, T.R. Derrick, E.H. Elliott (eds.), Proceedings of the XI Symposium of the International Society of Biomechanics in Sports, Amherst, MA, 1990, 154–158.
- [18] HENNING E., *Improvement of GPS accuracy for the tracking of human motion by the elimination of "Selective Availability" restrictions*, [in:] H. Gerber, R. Müller (eds.), International Society of Biomechanics XVIIIth Congress. Eidgenössische Technische Hochschule, Zürich 2001, S10.
- [19] International Ski Federation, *The International Ski Competition Rules (ICR); Book IV: Joint Regulations for Alpine Skiing*, Oberhofen/Thunersee (CH): Fédération Internationale de Ski, 2013.
- [20] MÖSSNER M., KAPS P., NACHBAUER W., *A method for obtaining 3-D data in alpine skiing using pan and tilt cameras with zoom lenses*, [in:] C.D. Mote, R.J. Johnson, W. Hauser, P.S. Schaff (eds.), *Ski Trauma and Skiing Safety: 10th Volume*, Philadelphia, Pa., American Society for Testing and Materials, 1996, 155–164.
- [21] MÜLLER E., *Biomechanics in skiing – a challenge on performance and safety*, [in:] F. Schena (ed.), International Congress "Mountain & Sport. Updating Study and Research from Laboratory to Field", Centro interuniversitario di ricerca in Bioingegneria e Scienze Motorie, Rovereto (TN), 2009, 15.
- [22] NACHBAUER W., *Fahrlinie in Torlauf und Riesentorlauf*, Leistungssport, 1986, 117(6), 17–21, (in German).
- [23] POZZO R., CANCLINI A., CASASOLA S., CIRO D., COTELLI CH., BARONI G., *3-D kinematic and kinetic analysis of G-slalom at Val Badia World Cup Race in 2002*, [in:] F. Schena (ed.), International Congress "Mountain and Sport. Updating Study and Research from Laboratory to Field", Programme and Book of Abstracts. Centro interuniversitario di ricerca in Bioingegneria e Scienze Motorie. Rovereto (TN), 2005, 48.
- [24] REID R.C., GILGIEN M., MORGER T., TJØRHOM H., HAUGEN P., KIPP R., SMITH G., *Turn characteristics and energy dissipation in slalom*, [in:] E. Müller, S. Lindinger, T. Stöggl (eds.), *Science and skiing IV*, Maidenhead: Meyer & Meyer Sport (UK) Ltd., 2009, 419–429.
- [25] SCHIESTL M., KAPS P., MÖSSNER M., NACHBAUER W., *Snow friction and drag during the downhill race in Kitzbühel*, Proceedings of the International Congress Mountain and Sport: Updating study and research from laboratory to field, Rovereto (ITA), 2005, 54.
- [26] SCHIESTL M., KAPS P., MÖSSNER M., NACHBAUER W., *Calculation of friction and reaction forces during an Alpine World Cup downhill race*, [in:] E.F. Moritz, S. Haake (eds.), *Engineering of Sport 6: Volume 1: Developments for Sports*, Springer, New York, 2006, 269–274.
- [27] SUPEJ M., KUGOVNIK O., NEMEC B., *Kinematic determination of the beginning of a ski turn*, Kinesiol. Slov. Sci. J. Sport., 2003, 9(1), 11–17.
- [28] USSA. *Information – Request for Alpine Homologation / Course Approval Inspection*, United States Skiing Association Alpine Course Approvals, Park City, UT, 2009. Available: www.nhara.org/homologation; access: 3 Nov. 2015.
- [29] WATANABE K., *Skiing research in Japan*, Med. Sci. Sports Exerc., 1981, 13, 205–209.