

# INVESTIGATION OF THE INFLUENCE OF CHEMICAL INTERACTION AFTERMARKET ADDITIVES ON LUBRICATING PROPERTIES OF MARINOL RG 1240 ENGINE OIL

Andrzej Młynarczak

Gdynia Maritime University  
Department of Marine Power Plant  
Morska Street 81-87, 81- 079 Gdynia, Poland  
tel.: +48 58 6901324  
e-mail: mlynek@am.gdynia.pl

## Abstract

The paper presents the results of lubricating properties tests of Marinol RG 1240 motor oil used in trunk piston marine diesel engines and modified by chemical interaction aftermarket additives – Motor Life Professional and Mind. The test results were collected by means of a four-ball extreme pressure tester T-02 according to Polish Norm PN-76/C-04147. The following lubricating properties parameters were determined: weld load  $P_z$ , maximum non-seizure load  $P_n$ , seizure load  $P_s$ , load wear index  $I_h$  and load limit of wear  $G_{oz}$ .

Investigations showed that tested chemical interaction aftermarket additives improve load wear index  $I_h$  and seizure load  $P_s$  (in case of Motor Life Professional), simultaneously impair maximum non-seizure load  $P_n$ . Weld load  $P_z$  remains on the same level. But the load limit of wear  $G_{oz}$  which characterises the wear resistance in extremely hard working conditions increases considerably- 542% for tested oil with the addition of 5% by volume of Motor Life Professional and 520% with the addition of 5% by volume of Mind additive. These results indicates that tested aftermarket additives can form additional boundary layer (independent of lubricating oil boundary layer) which activates in extreme working conditions (very high temperatures and loads) of the sliding node elements. That layer could protect machines elements against seizure.

In authors opinion, modifying of motor oils (provided with antiwear and antiseizure additives by the manufacturer) by chemical interaction aftermarket additives can increase durability and reliability of the machine elements especially in hard working condition for example frequent starts and load changes, overloads, operation in polluted atmosphere (transport, mining, building engineering etc.).

**Keywords:** trunk piston marine diesel engine, lubricating oil, lubricating properties, aftermarket additive

## 1. Introduction

Lubricating oils are characterized by improving quality. It is obtained by additives which are the integral part of the lubricants. Nevertheless, in extreme hard working conditions of the tribosystems (high pressures, velocities and temperatures, temporary lubricating lack during starting) the machine elements are not secured enough. In connection with it the idea to introduce the additional substance – aftermarket additive into tribosystems (with the lubricating oils) was put forward.

A revive of the literature about the influence of aftermarket additives on the tribosystem elements working conditions shows that there is no consensus on this subject. Different opinions about aftermarket additives functioning can be found in the professional literature – from harmfulness or weak effectiveness to good efficiency and big technical, economical and ecological meaning [1, 5, 7, 8]. So different opinions come from big variety of aftermarket additives (chemical interaction additives, additives which contain molecules of solid lubricants, additives which are able to form conditions for selective transfer lubrication [1]) and their various principles of operation.

Nowadays, the chemical interaction additives have the widest application. These additives join permanently with lubricating oil, so they do not precipitate on the filters and do not create heat-insulating layers unlike the additives which contain molecules of solid lubricants (for example politetrafluoroethylene – PTFE).

Scientific research results [2-4] show that in case of engine oils provided by the manufacturer with antiwear (AW) and antiseizure (EP) additives, additional modification of oils by aftermarket additives do not improve or negligibly improve lubricating properties parameters. Therefore, modification of engine oils by aftermarket additives may, in authors' opinion, raise doubts.

The paper presents the results of lubricating properties tests of Marinol RG 1240 motor oil used in trunk piston marine diesel engines and modified by the Motor Life Professional or Mind chemical interaction aftermarket additives. The test results were collected by means of a four-ball extreme pressure tester T-02 according to Polish Norm PN-76/C-04147.

## 2. Test stand and research method

The test results were collected by means of a four-ball extreme pressure tester T-02 which was provided with computer aided control and measurement systems. This apparatus was designed and manufactured at ITeE in Radom for the purpose of measuring motion resistance, wear and anti-seizure abilities in the presence of lubricant. The methodology of the tests is compatible with the Polish Norm (PN-76/C-04147) and was described in [9-11].

The tribosystem, presented below on the Fig. 1, consists of four chrome alloy bearing steel balls (100 Cr6) with diameter 12.7 mm (0.5 in.), surface roughness  $Ra = 0.032 \mu\text{m}$  and Rockwell hardness 60 HRC. Three stationary lower balls (2) are fixed in the ball pot (4) and pressed at the required load  $P$  against the top ball (1). The top ball is fixed in the ball chuck (3) and rotates at the defined speed  $n$ . In this way, pure sliding appears between the balls. Rotational of the top ball causes frictional torque, which produces a scar on the three lower balls. The contact zone of the balls was immersed in the tested lubricant. A very important feature of T-02 tester is the possibility of continuous increase of load  $P$  during a run. Also rotational speed  $n$  can be changed within a wide range.

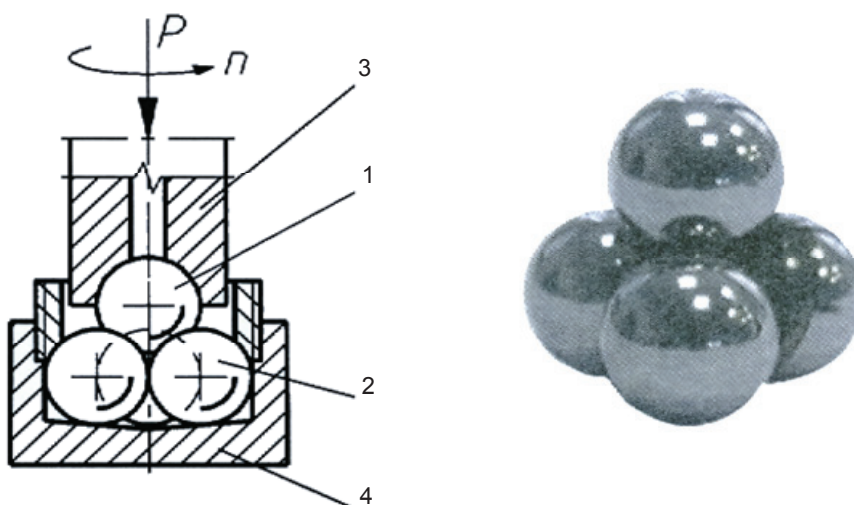

Fig. 1. Friction node of four-ball tester: 1 – top ball, 2 – lower balls, 3 - top ball chuck, 4 – lower balls pot [12]

Research was executed for Marinol RG 1240 oil used for trunk piston marine diesel light fuel engines. Marinol RG 1240 is formulated on the base of deeply refined, solvent dewaxed and hydrotreated oil distillates received from crude oil. It contains a properly selected package of washing and dispersing additives as well as anti-oxidising, anticorrosion, antirust, anti-wear attributes and meets the API CD requirements.

Marinol RG 1240 motor oil was modified, approximately 5% in volume, by the Motor Life Professional or Mind chemical interaction aftermarket additives. The following lubricating properties parameters were determined according to Polish Norm PN-76/C-04147: weld load  $P_z$ , maximum non-seizure load  $P_n$ , seizure load  $P_t$ , load wear index  $I_h$  and load limit of wear  $G_{oz}$ .

In the first stage the following parameters were assumed: maximum non-seizure load  $P_n$ , weld load  $P_z$  and load wear index  $I_h$ . The wear characteristic ( $d = f(P)$ ), for the applied load was determined at room temperature, from 10-s runs of the set of four steel balls. The top ball rotated at 1450 rpm. The first test was performed under applied load  $F = 784.8$  N. The load was stepped up (in accordance with the standard) in the next tests until the rotating ball became welded to the three fixed balls. New balls were used for each test, and all pieces and balls were first cleaned with solvent and then dried. In order to assess' antiwear properties of the tested lubricants, after each experiment the wear scar diameters of the balls were measured under a magnifying glass with an accuracy of 0.1 mm. On each of the three lower balls, two measurements of the wear spots were made: parallel and perpendicular to the motion and the average scar diameters were calculated. For each load one run was performed, but when welding occurred, check runs were made.

In order to assess seizure load  $P_t$ , tests with linearly increasing load were performed. During the measurements, the load increased from 0 to about 7400 N with constant speed of 409 N/s. The rotational speed was also constant, equal to 500 rpm. The load increasing time was approximately 18 s – until the highest load was reached. It is assumed that the test finishes when seizure takes place, i.e. at the time of exceeding 10 Nm friction torque. If seizure is not detected, attaining of maximum load finishes the test. For each tested lubricant at least three runs were performed and the results averaged.

In order to determine load limit of wear  $G_{oz}$ , the load (1471.5 N) and revolutions of the upper ball (500 rpm) were constant during 60-s runs. The tests were repeated three times for each measuring point. After each experiment wear scar diameters of the balls were measured in the same way like it was described above.

### 3. Research results

Results of lubricating properties tests of Marinol RG 1240 marine engine oil and modified by the Motor Life Professional or Mind aftermarket additives are given in Tab. 1 and Fig. 2-4.

Figure 2 presents comparison of the following lubricating properties parameters: maximum non-seizure load  $P_n$ , seizure load  $P_t$ , load wear index  $I_h$  and weld load  $P_z$ . The maximum non-seizure load  $P_n$  and seizure load  $P_t$  characterize boundary layer resistance and serve to determine conditions in which destroying of these layer takes place and seizing begins. Weld load  $P_z$  and load wear index  $I_h$  show antiseizure properties of the lubricant. It is shown that:

- maximum non-seizure load  $P_n$  decreases from 981 N in case of Marinol RG 1240 to 784,8 N in case of Marinol RG 1240 modified by tested aftermarket additives,
- weld load  $P_z$  remains on the same level - 1962 N,
- load wear index  $I_h$  increases from 214 N for Marinol RG 1240 engine oil to 257 N for Marinol RG 1240 with Mind addition and 410 N for Marinol RG 1240 with Motor Life Professional addition,
- seizure load  $P_t$  is the same for Marinol RG 1240 engine oil and Marinol RG 1240 with Mind addition (2250 N), Motor Life Professional addition increases slightly this parameter to 2500 N.

One can observe that obtained results are ambiguous. Tested aftermarket additives impair maximum non-seizure load  $P_n$ . Maximum non-seizure load is a presentation of load carrying capacity of lubricating oil (antiwear properties). In authors opinion it can be caused by viscosity growth of lubricating oil and aftermarket additive mixture. Lower viscosity lubricating oils can easier penetrate between matching elements thus improving lubrication and finally decreasing wear [13]. On the other hand seizure load  $P_t$  which also characterizes boundary layer resistance increases in case of Motor Life Professional addition. It means that scuffing initiation will take place at a little bit higher load (2500 N).

Modifying of Marinol RG 1240 by Motor Life Professional or Mind increases load wear index  $I_h$ . The load wear index is calculated according to Polish Norm PN-76/C-04147 and its growth results from lower scar diameters measured on the balls. The wear scar diameters of four-ball test,

running in Marinol RG 1240 engine oil and that oil with tested chemical interaction aftermarket additives are presented in Fig. 3. Only for the lowest load (981 N) the scar diameters on the balls are bigger in case of Marinol RG 1240 engine oil with chemical interaction aftermarket additive addition. For higher loads of the sliding node the scar diameters are lower in for oil modified by aftermarket additives. The larger the wear scar is, the more severe the wear is. Therefore, Marinol RG 1240 engine oil with Motor Life Professional or Mind additive possesses higher wear resistance but this important feature activates at higher loads.

From Fig. 4 it can be seen that modification of the Marinol RG 1240 engine oil by Motor Life Professional or Mind aftermarket additives considerable increases the wear resistance characterized by parameter  $G_{oz}$ . The load limit of wear increases by 542% for Marinol RG 1240 with the addition of 5% by volume of Motor Life Professional additive (from 589 N/mm<sup>2</sup> to 3191 N/mm<sup>2</sup>) and 520% with the addition of 5% by volume of Mind additive (from 589 N/mm<sup>2</sup> to 3061 N/mm<sup>2</sup>). These results indicates that tested chemical interaction aftermarket additives can form additional boundary layer (independent of lubricating oil boundary layer) which activates in extreme working conditions (very high temperatures and loads) of the sliding node elements. That layer is characterised by big overload capacity and finally could protect machines elements against seizure.

Comparing two tested chemical interaction aftermarket additives – Motor Life Professional and Mind it can be seen from Tab. 1 and Fig. 2-4 that a little bit better lubricating properties has Motor Life Professional (higher load wear index  $I_h$ , seizure load  $P_t$  and load limit of wear  $G_{oz}$ ).

In the future investigations the scanning electron microscopy should be used to study the topography and shape of the scars produced. This may help to explain the protective mechanism of the tested aftermarket additives.

Tab. 1. Lubricating properties of Marinol RG 1240 engine oil and modified by Motor Life Professional or Mind aftermarket additives

Lubricating properties parameters	MARINOL RG 1240	MARINOL RG 1240 + 5% MOTOR LIFE PROFESSIONAL	MARINOL RG 1240 + 5% MIND
$P_n$ [N]	981	785	785
$P_z$ [N]	1962	1962	1962
$I_h$ [N]	214	410	257
$P_t$ [N]	2250	2500	2250
$G_{oz}$ [N/mm <sup>2</sup> ]	589	3191	3061

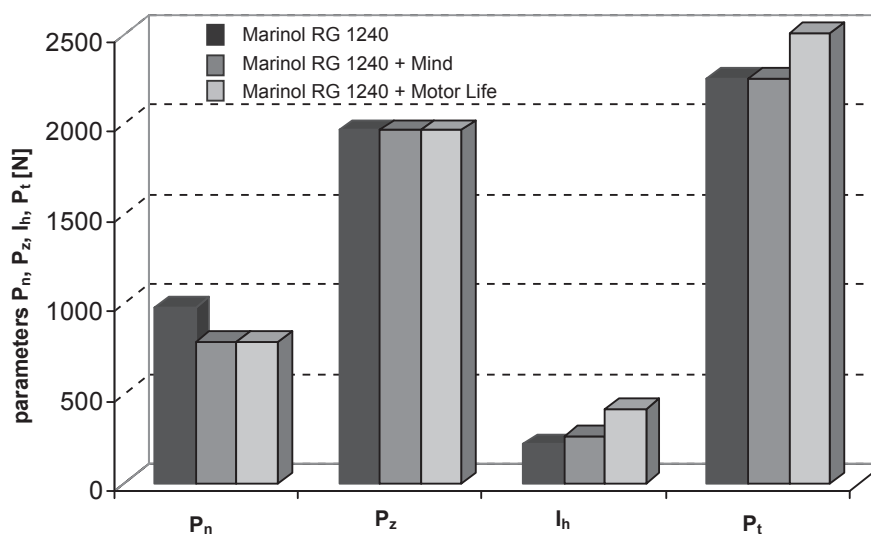

Fig. 2. Lubricating properties of Marinol RG 1240 engine oil modified by aftermarket additives

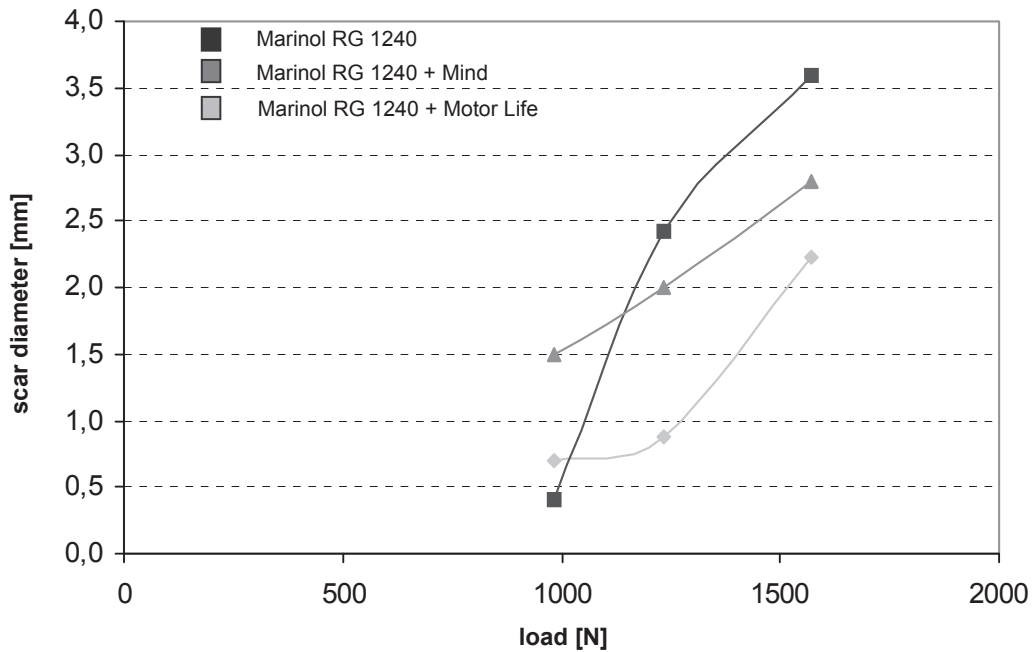

Fig. 3. Wear scar diameters in load function for tested lubricants

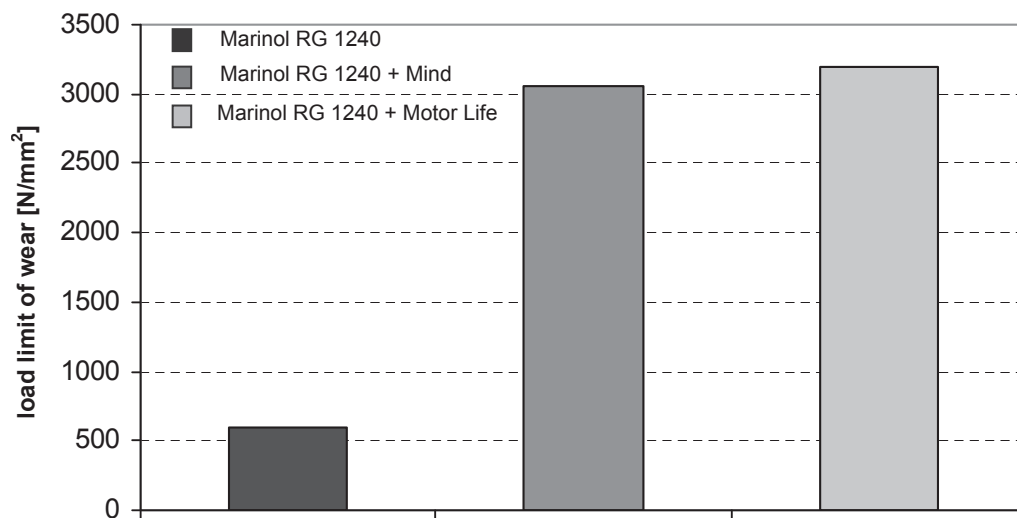

Fig. 4. The load limit of wear for tested lubricants

#### 4. Conclusions

The following conclusions can be drawn from the results presented above:

1. Obtained results are ambiguous. Investigations showed that tested chemical interaction aftermarket additives improve load wear index  $I_h$ , and seizure load  $P_t$  (in case of Motor Life Professional), simultaneously impair maximum non-seizure load  $P_n$ . Weld load  $P_z$  remains on the same level.
2. Modification of the Marinol RG 1240 engine oil by tested chemical interaction aftermarket additives considerable increases the wear resistance characterized by parameter  $G_{oz}$ . The load limit of wear  $G_{oz}$  increases by 542% for tested oil with the addition of 5% by volume of Motor Life Professional and 520% with the addition of 5% by volume of Mind additive. These results indicates that tested aftermarket additives can form additional boundary layer (independent of



lubricating oil boundary layer) which activates in extreme working conditions of the sliding node elements. That layer could protect machines elements against seizure.

3. In the future investigations the scanning electron microscopy should be used to study the topography and shape of the scars produced. This may help to explain the protective mechanism of the tested aftermarket additives.
4. Modifying of motor oils (provided with antiwear and antiseizure additives by the manufacturer) by aftermarket additives can bring some advantages but only in hard working condition of the engines for example frequent starts and load changes, overloads, operation in polluted atmosphere etc.

## References

- [1] Laber, S., *Badania własności eksploatacyjnych i smarnych uszlachetnicza metalu*, Uniwersytet Zielonogórski, 2003.
- [2] Laber, A., *Analiza możliwości wykorzystania preparatu eksploatacyjnego Motor Life Professional w modyfikowaniu warunków pracy węzłów tarcia pojazdów samochodowych*, Tribologia 5, 2009.
- [3] Laber, S., Laber, A., *Ocena własności smarnych wybranych środków smarowych stosowanych w eksploatacji urządzeń dźwigowych*, Tribologia, Nr 4, 2010.
- [4] Laber, S., Adamczuk, K., *Właściwości tribologiczne węzła tarcia z wykorzystaniem wybranych gatunków brązów*, Tribologia, Nr 6, 2010.
- [5] Łuksa, A., Witkoś, A., *Dodatki uszlachetniające do olejów smarowych*, Paliwa, oleje i smary w eksploatacji, Nr 19, 1995.
- [6] *Materiały informacyjne dotyczące preparatu eksploatacyjnego Motor Life Professional*, Plastmal, Warszawa 2007.
- [7] Mc Fall, D., *Dwugłos na temat dodatków wspomagających do olejów*, Paliwa, oleje i smary w eksploatacji, Nr 69, 2000.
- [8] Młynarczak, A., *Research on purification of the marine engine oil with chemical interaction preparation*, Journal of KONES Powertrain and Transport, Vol. 17, No. 2, 2010.
- [9] Piekoszewski, W., Szczerek, M., Tuszyński, W., *The action of lubricants under extreme pressure conditions in a modified four-ball tester*, pp. 183-193, Wear 240, 2001.
- [10] PN-76/C-04147, *Badanie własności smarnych olejów i smarów*.
- [11] Szczerek, M., Tuszyński, W., *Tribological Tests, Scuffing*, Publ. IteE, Radom, Poland 2000.
- [12] *T-02U Aparat czterokulowy, Instrukcja obsługi*, Instytut Technologii Eksploatacji, Radom 2011.
- [13] Włodarski, J. K., *Podstawy eksploatacji maszyn okrętowych. Tarcie i zużycie*, Wydawnictwo Akademii Morskiej w Gdyni, Gdynia 2006.