

Optimal sizing and cost analysis of hybrid power system for a stand-alone application in Coimbatore region: a case study

T. BOGARAJ, J. KANAKARAJ, K. MOHAN KUMAR

*Department of Electrical and Electronics Engineering
PSG College of Technology, Coimbatore, Tamil Nadu, India
e-mail: tbr@eee.psgtech.ac.in*

(Received: 28.07.2014, revised: 20.11.2014)

Abstract: This paper presents the optimal sizing of PV/Wind/Fuel Cell/Battery Hybrid Energy System for energizing a Small Scale Industrial Application or a village domestic load of 200 kW. HOMER software is used for simulation of the complete system. The solar radiation data and wind speed data used in this paper are for the place of Coimbatore, Tamil Nadu, India which is located 11.0183° N longitude and 76.9725° E latitude. The optimized sizes of components of Hybrid Power System (HPS) are found based on Levelised Cost of Energy (LCE) and total Net Present Cost (NPC). The results are presented and compared for five different combinations of HPS components. Suggestions are also presented to choose the low cost system which produces energy at low LCE.

Key words: hybrid power system, optimal sizing, cost analysis, renewable energy sources, net present cost, levelised cost of energy, HOMER

1. Introduction

Nowadays, the mankind is living in energy crisis. The most optimist forecasts reveal the fact that the main classic (Fossil Fuel) energy resources such as coal, oil and natural gas will be exhausted by 2050. Also, the combustion causes the greenhouse effect which will determine an apocalyptic scenario in the next 80-100 years. In this scenario, the only solution is finding and using new energy resources, inexhaustible and clean [1, 3], which will substitute in the next 50 years the current resources based on fossil fuels. The growing share of renewable energy production is predictable but depends both on reducing the production costs and on finding new electrical energy storage solutions. This will ensure the large quantities of renewable energy injection into the power system.

In order to find the optimal investment cost of renewable energy system and reduce the energy production cost the optimal ratings of the system components need to be determined. This is an optimization problem that optimizes the capacity of Hybrid Power System components. In this paper a HPS consisting of PV source, Wind Generator, Battery, Fuel Cell,

Converters are considered to match the local production with local load demand. HOMER tool is used to find the optimal size of HPS components and analyse based on the Levelised Cost of Energy (LCE) and Net Present Cost (NPC) [1-6].

The third largest city of the state, Coimbatore is one among the industrially developed and commercially vibrant districts of Tamil Nadu, India. It has got high concentration (about 30,000) of small, medium and large scale industries. It is known as the Manchester of South India because of its well-developed textile industries and other industrial base. Also it is one of the Educational hubs of Tamil Nadu. The Report 'Brief Industrial Profile of Coimbatore District' prepared by Ministry of Micro, Small and Medium Enterprises (MSME), India for the year 2012-13 states that power generation by renewable energy sources is the key industrial growth required in Coimbatore Region [7]. In this aspect this paper will be useful for the Small and Medium Industries, Academic Institutions, and Government agencies to do cost analysis of HPS when they desire to go for renewable power generation. This will help in reducing carbon emissions and distributed power generation which will make the enterprises independent from the grid.

2. Hybrid power system

The HPS considered in this paper consists of a PV system, Wind Generator, Batteries, Fuel Cell, Electrolyser, Converters and load of 200 kW. The load is considered to be of two categories i) Fixed load with peak of 200 kW ii) Deferrable load with peak of 10 kW. The configuration of Hybrid Power System considered in this paper is shown in Figure 1. PV and Wind Generators are the main energy sources.

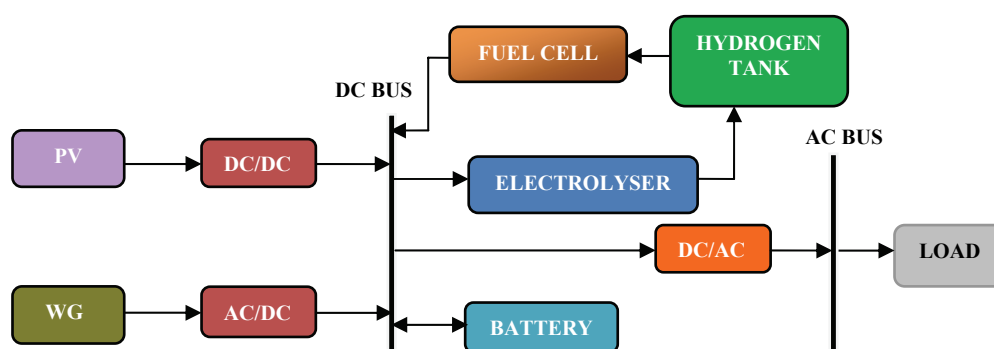

Fig. 1. Scheme of PV/Wind/Fuel Cell/Battery Hybrid Power System

The hybrid power system meets the load in the following configurations:

- 1) The extra energy after meeting the load is used to charge the batteries. If the battery is fully charged and even then there is extra energy available, the electrolyser produces hydrogen by electrolysis and is stored in Hydrogen Tank.

- 2) If the load demand is not met by the sources the additional energy required to meet the load is supplemented by Fuel cell first and then by the battery. Due to less number of switching of the batteries extends their life.
- 3) If wind speed is below critical wind speed, PV alone will supply the load with Batteries and Fuel cell as the additional sources.
- 4) If PV energy is not available, WG with Batteries and Fuel cell as the additional sources will supply the load.
- 5) If both PV and WG energy are not available, the load is met by Batteries and Fuel cell.

3. HPS Implementation using HOMER

HOMER (Hybrid Optimization Model for Electric Renewable) [8] is computer software developed by National Renewable Energy Laboratory (NREL), Colorado, United States since 1993. It simplifies the task of evaluating design options for off-grid stand-alone power systems, hybrid power systems and distributed generation (DG) applications. Specifically HOMER has been developed to meet the needs of renewable energy industry's system analysis and optimization.

Finding the optimal size of HPS components using HOMER involves the following steps [5]:

Step 1: All the possible combinations of system components for supplying the consumer load are determined.

Step 2: The energy balance for 8760 h/year and all the possible combinations to provide the energy are determined; A full economical estimation considering all the cost including the initial investments, maintenance, repairing, modernization, interests and benefits is computed for every alternative.

Step 3: Optimized size of components of HPS determined economically and proposed solutions are presented in ascending order of costs per life cycle.

Step 4: Sensitivity indexes of the results considering the variations of the input data are computed. Finally, the user can decide the best solution to choose for the optimal size with the feasibility and lower cost for the selected location and load.

The HOMER software can generate the clearness index from the solar radiation data according to the latitude of the place chosen. If the solar radiation data is not available, clearness index can also be used to generate the solar radiation data. Therefore, either the clearness index or the solar radiation data can be used to represent the solar resource input, as long as the data of latitude is available to the HOMER software. This research paper unfolds the technical feasibility of implanting a micro-grid at Coimbatore taking consideration of all environmental factors at 11°59' north latitude and 76°59' east longitudes of Tamilnadu. The monthly Average of Daily Solar radiation and Wind speed of Coimbatore is listed in Table 1. The same is used for simulation in HOMER and are shown in Figures 2-3 respectively.

4. Resources at Coimbatore

Table 1. Average monthly solar and wind data at Coimbatore

Month	Daily solar radiation (kWh/m ² /day)	Wind speed (m/s) at 50 m height
Jan	5.459	7
Feb	6.375	8
Mar	6.746	9
Apr	6.502	10
May	5.720	14
Jun	4.673	19
Jul	4.503	19
Aug	4.592	18
Sep	5.123	15
Oct	4.809	9
Nov	4.811	6
Dec	5.054	6

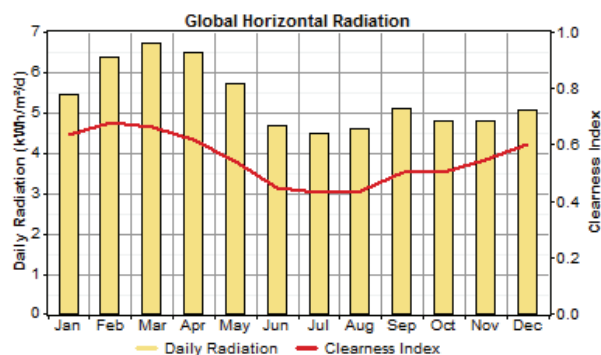

Fig. 2. Solar irradiation at Coimbatore

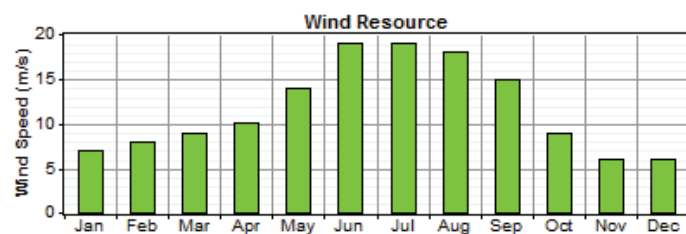

Fig. 3. Wind speed at Coimbatore

5. Load profile

For the case study, a medium size extra-urban residential area in Coimbatore, Peelamedu is considered. Each house accommodates 3-4 persons and has an installed electrical capacity of about 5 kW. For all the considered area, the primary load is scaled to an annual average of 1500 kWh/d and a peak of 200 kW and the deferrable load scaled to an annual average of 2.83 kWh/d and a peak of 10 kW. The daily profile of the load simulated in HOMER is shown in Figure 4. The monthly average of primary load and deferrable load are shown in Figure 5 and Figure 6 respectively.

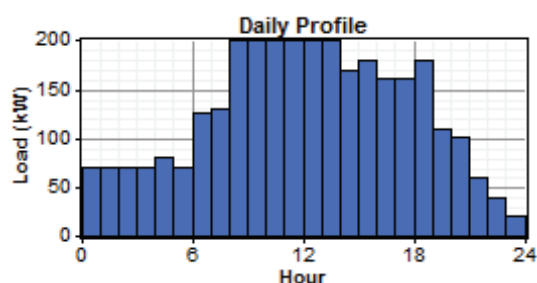

Fig. 4. Load profile for a day

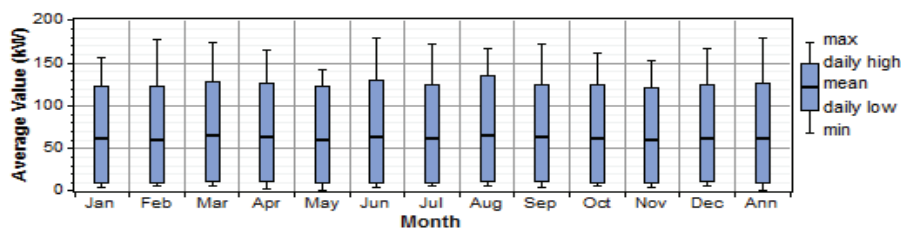

Fig. 5. Monthly profile of the primary load

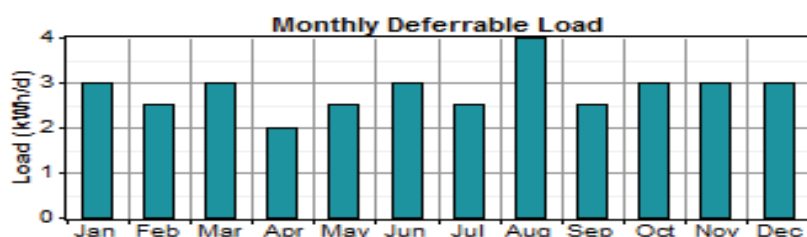

Fig. 6. Monthly profile of the deferrable load

6. Economic criteria based on LCC (Life Cycle Cost) concept

In this study the economic analysis is based on Life Cycle cost of the HPS, which is the best indicator of economic profitability of system cost. Total cost of the system is calculated

for useful lifetime of the system in this method. This method considers the capital cost and all other costs for the proper functioning of the system over its lifetime. LCC includes the initial capital cost (C_{ic}), the present value of replacement cost (C_{rep}), the present value of operation and maintenance cost ($C_{O\&M}$), and the salvage value (SAL). So, LCC is written as

$$LCC = C_{ic} + C_{rep} + C_{O\&M} - SAL. \quad (1)$$

6.1. Initial capital cost

The capital cost of each system component includes component price, system design cost and installation cost. Then the initial capital cost (CIC) for the PV/Wind/Battery/Fuel Cell HPS is given by:

$$C_{ic} = (P_{pv} * c_{ipv}) + (P_w * c_{iw}) + (P_{inv} * c_{iinv}) + \\ + (C_{bt} * c_{ibat}) + (P_{hy} * c_{ihy}) + (P_e * c_{ie}) + (P_f * c_{if}), \quad (2)$$

where: (P_{pv} , c_{ipv}) are the total capacity (kW) and unit cost (\$/kW) of PV array, (P_w , c_{iw}) are the total capacity (kW) and unit cost (\$/kW) of wind turbine, (C_{bt} , c_{ibat}) are the total capacity (kWh) and unit cost (\$/kWh) of the battery bank, (P_{inv} , c_{iinv}) are the nominal capacity (kW) and unit cost (\$/kW) of the inverter, (P_{hy} , c_{ihy}) are the total capacity (kW) and unit cost (\$/kW) of hydrogen tank, (P_e , c_{ie}) are the total capacity (kW) and unit cost (\$/kW) of electrolyser and (P_f , c_{if}) are the total capacity (kW) and unit cost (\$/kW) of fuel cell.

6.2. Replacement cost

System component may fail before its lifetime expectancy due to any environmental effects, mishandling, overload etc. In such cases replacement of System components is required. Major repairs and equipment replacements are the main components of Replacement costs. Lifetime of PV system is more than Wind Turbine, Battery bank, Fuel Cell and Inverter. The replacement cost of the Wind Turbine, Batteries, Fuel Cell and Inverter are taken into account for the cost analysis of the HPS. The Life time of the wind turbine is taken as 15 years. Hence, the replacement cost of wind turbine is calculated by

$$C_{repw} = P_w * C_{repw} * \left[-\frac{1}{(1+i)^{15}} \right]. \quad (3)$$

Assuming the battery bank will be replaced after $N = 6, 12, 18,$ and 24 years. Therefore, the replacement cost of battery bank is given by

$$C_{repb} = C_{bt} * C_{repb} * \left[\frac{1}{(1+i)^6} + \frac{1}{(1+i)^{12}} + \frac{1}{(1+i)^{18}} + \frac{1}{(1+i)^{24}} \right]. \quad (4)$$

Lifetime of the Fuel cell is taken as 7 years. The replacement cost of the fuel cell is

$$C_{repf} = P_f * C_{repf} * \left[\frac{1}{(1+i)^7} + \frac{1}{(1+i)^{14}} + \frac{1}{(1+i)^{21}} \right]. \quad (5)$$

The lifetime of the inverter is also 15 years, so the replacement cost of inverter can be calculated as

$$C_{repinv} = P_{inv} * c_{repinv} * \left[-\frac{1}{(1+i)^{15}} \right]. \quad (6)$$

The present value of total replacement cost (C_{rep}) is the sum of all replacement costs and is given by

$$C_{rep} = C_{reppv} + C_{repw} + C_{repbat} + C_{repf} + C_{repinv}, \quad (7)$$

where C_{rep} is the total system replacement cost, (C_{reppv} , C_{repw}) are the replacement cost of PV array (\$) and the replacement cost of wind turbine (\$) respectively, (C_{repbat} , C_{repf} , C_{repinv}) are the unit component cost of battery bank (\$/kWh), Fuel Cell (\$/kW) and inverter (\$/kW) respectively, and i is the interest rate assumed as 10%.

6.3. Operation and maintenance cost

The present value of operation and maintenance cost of the PV/Wind/Battery/Fuel Cell system ($C_{O\&M}$) is expressed as

$$\begin{aligned} C_{O\&M} = & (P_{pv} * C_{O\&M}_{pv} * PWF_{O\&M}) + (P_w * C_{O\&M}_w * PWF_{O\&M}) + \\ & + (P_{inv} * C_{O\&M}_{inv} * PWF_{O\&M}) + (C_{bt} * C_{O\&M}_{bat} * PWF_{O\&M}) + \\ & + (V_{hy} * C_{O\&M}_{hy} * PWF_{O\&M}) + (C_{el} * C_{O\&M}_{el} * PWF_{O\&M}) + \\ & + (P_f * C_{O\&M}_f * PWF_{O\&M}), \end{aligned} \quad (8)$$

where ($C_{O\&M}_{pv}$, $C_{O\&M}_w$, $C_{O\&M}_{bat}$, $C_{O\&M}_{inv}$, $C_{O\&M}_{hy}$, $C_{O\&M}_{el}$, $C_{O\&M}_f$) are the operation and maintenance costs (\$) of PV, wind turbine, battery bank, inverter, Hydrogen Tank, Electrolyser, and Fuel cell respectively; V_{hy} , C_{el} are capacity of Hydrogen tank (m^3), Electrolyser (m^3/hr) respectively;

The Present Worth Factor of operation and maintenance in Eq. (8) ($PWF_{O\&M}$) is calculated as

$$PWF_{O\&M} = \left[\frac{(1+i)^N - 1}{i(1+i)^N} \right], \quad (9)$$

where N is the lifetime of system.

6.4. Salvage value

Salvage value represents the residual value of equipments for the other uses at the end of project time. In this study salvage value can be calculated as

$$SAL = C_{rep} \frac{R_{rem}}{R_{comp}}, \quad (10)$$

where C_{rep} is replacement cost (\$), R_{comp} is component lifetime (year), and R_{rem} is the remaining life of the component at the end of the project lifetime (year). R_{rem} is calculated by

$$R_{rem} = R_{comp} - INT * [N - R_{rep}], \quad (11)$$

where R_{rep} , the replacement cost duration (year), and is given by:

$$R_{rem} = R_{comp} * INT * \left[\frac{N}{R_{proj}} \right], \quad (12)$$

where R_{proj} is project lifetime (year) [5].

7. Simulation results and discussion

The ratings of HPS and number of units considered for the cost analysis are listed in Table 2.

The system components are simulated in HOMER and its integration is shown in Figure 7. An optimization result of the considered system with lowest NPC of system configuration occupies the top as shown in Figure 8. Five possible combination of system components are considered to form the HPS [6]. Discussions based on ratings of the componenets, NPC & LCE of the system is presented for each case considered. The Cash Flow Summary which results from HOMER for cases A-E are shown in Figures 9-13 respectively.

Table 2. Ratings of HPS Components considered

Component	Rating/ No. of units
Photovoltaic array	PV of sizes 250 kW, 500 kW, 750 kW and 1000 kW are considered
Wind generator	6 Units of 250 kW NEPC wind generators
Fuel cell	Fuel cells with 100 kW is considered to meet the requirements. The fuel input to the system is liquid hydrogen
Battery	Batteries with string numbers 0-16 and each string having 100 batteries are connected to supply the bus requirement of 600 V
Converter	Converters with capacity 300 kW are used for dc/ac conversions
Electrolyser	The electrolyzer unit of sizes 100 kW and 150 kW are included to store the hydrogen fuel and supply when needed
Hydrogen tank	A hydrogen tank with 100 kg capacity is used for the supply needs

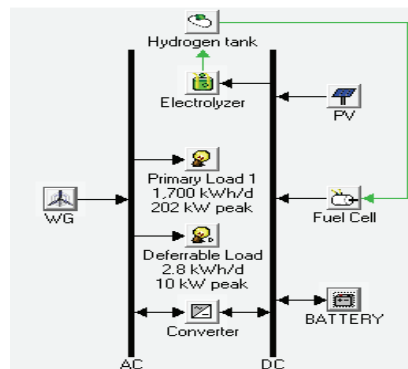

Fig. 7. Proposed architecture of the Micro-Grid simulated in HOMER

	PV (kW)	India	FC (kW)	BAT	Conv. (kW)	Elec. (kW)	H2 Tank (kg)	Efficiency Measures	Initial Capital	Operating Cost (\$/yr)	Total NPC	COE (\$/kWh)	Ren. Frac.	Capacity Shortage	FC (hrs)	Batt. Lf. (yr)
	500	1		800	300			No	\$ 1,680,000	29,635	\$ 1,996,343	0.344	1.00	0.01		12.0
	500	1	50	400	300	100	100	No	\$ 1,780,000	27,200	\$ 2,070,352	0.357	1.00	0.02	534	12.0
	500	1		800	300	100		No	\$ 1,880,000	34,629	\$ 2,249,657	0.387	1.00	0.01		12.0
	1000			800	300			No	\$ 1,970,000	33,062	\$ 2,322,934	0.397	1.00	0.00		12.0
	1000		50	400	300	100	100	No	\$ 2,070,000	30,558	\$ 2,396,205	0.410	1.00	0.00	523	12.0
	1000			800	300	100		No	\$ 2,170,000	38,057	\$ 2,576,248	0.441	1.00	0.00		12.0
	1000	2	100		300	150	100	No	\$ 2,240,000	165,228	\$ 4,003,774	0.689	1.00	0.02	8,730	

Fig. 8. Optimization results by HOMER

7.1. CASE A: PV/battery system

PV is used as the primary source which produces DC power which is converted into AC power by using an inverter. Since the PV will charge the battery bank, when there is extra power after meeting the demand of the end user load. If the PV cannot meet the demand, the battery bank will not be charged, but being discharged to cater for the demand.

The optimal unit size of each component in Case A are detailed in Table 3. Total Net Present Cost (comprise of capital, replacement, O&M and salvage) of the PV stand-alone system and its each component is illustrated in Table 4. The Levelized Cost of Energy (LCE) for Case A is equal to 0.398 \$/kWh.

Table 3. System components in case A

Component	Rating
PV Array	1,000 kW
Battery	800 Batteries
Inverter	300 kW
Rectifier	300 kW

Table 4. System net present costs in case A

Component	Capital	Replacement	O&M	Fuel	Salvage	Total
	(\$)	(\$)	(\$)	(\$)	(\$)	(\$)
PV	900 000	193 093	0	0	-98 562	994 531
Battery	800 000	133 155	85 398	0	-32 124	986 429
Converter	270 000	85 115	0	0	-13 142	341 974
System	1 970 000	411 364	85 398	0	-143 828	2 322 935

7.2. Case B: PV/wind/battery power system

This case has considered only battery as energy storage option with PV/Wind energy power system as primary sources.

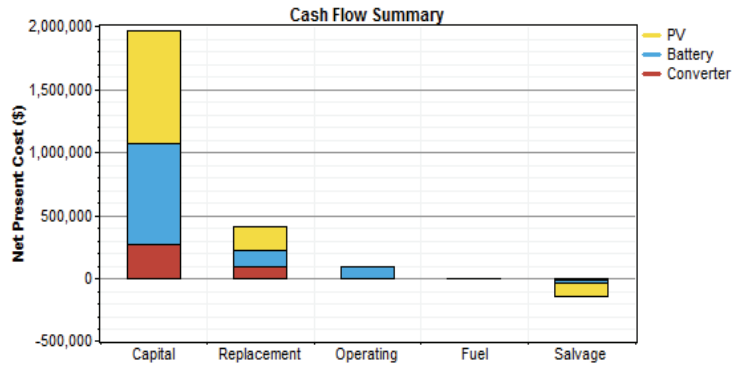

Fig. 9. Cash flow summary in case A

Table 5. System architecture in case B

Component	Rating
PV array	500 kW
Wind turbine	250 kW
Battery	400 battery
Inverter	300 kW
Rectifier	300 kW

Table 6. System net present costs in case B

Component	Capital	Replacement	O&M	Fuel	Salvage	Total
	(\$)	(\$)	(\$)	(\$)	(\$)	(\$)
PV	450 000	96 547	0	0	-49 281	497 266
WG	160 000	0	10 675	0	0	170 675
Battery	400 000	66 578	42 699	0	-16 062	493 215
Converter	270 000	85 115	0	0	-13 142	341 974
System	1 280 000	248 239	53 374	0	-78 485	1 503 129

The optimal unit size of each component in the system is listed in Table 5. Total NPC of the complete system and its component is illustrated in Table 6, which is much smaller compared to Case A due to the reduction in initial cost employed by PV arrays. The LCE for this case is 0.344 \$/kWh which is slightly smaller than Case A and it is found to be the optimal system of all configurations possible.

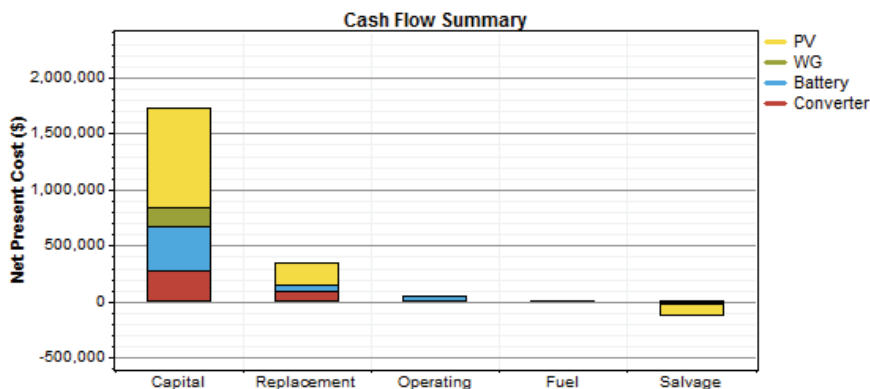

Fig. 10. Cash flow summary in case B

7.3. Case C: PV/wind/battery/fuel cell power system

In this case battery as well as fuel cell is considered as energy storage options with PV/Wind as primary power system.

Table 7. System architecture in case C

Component	Rating
PV array	500 kW
Wind turbine	1 WG
Fuel cell	50 kW
Battery	400
Inverter	300 kW
Rectifier	300 kW
Electrolyzer	100 kW
Hydrogen tank	100 kg
Dispatch strategy	Cycle charging

Under the load following strategy, renewable power sources charge the battery whereas under the cycle-charging strategy, whenever the generators operate, they produce more power than required to serve the load with surplus electricity going to charge the battery bank and ensuring continuity of power supply.

Table 7 shows the optimal unit size and number of units of each component in the system. Total NPC of the PV/Wind/Fuel Cell/Battery system and its each component is illustrated in Table 8. The LCE for Case C is equal to 0.357 \$/kWh. It is found that the NPC of this case is less than Case A, but slightly greater than Case B.

Table 8. System net present costs in case C

Component	Capital	Replacement	O&M	Fuel	Salvage	Total
	(\$)	(\$)	(\$)	(\$)	(\$)	(\$)
PV	450 000	96 547	0	0	-49 281	497 266
WG	160 000	0	10 675	0	0	170 675
Fuel cell	150 000	0	28 502	0	-14 593	163 909
Battery	400 000	66 578	42 699	0	-16 062	493 215
Converter	270 000	85 115	0	0	-13 142	341 974
Electrolyzer	200 000	63 048	0	0	-9 735	253 314
Hydrogen tank	150 000	0	0	0	0	150 000
System	1 780 000	311 288	81 875	0	-102 812	2 070 352

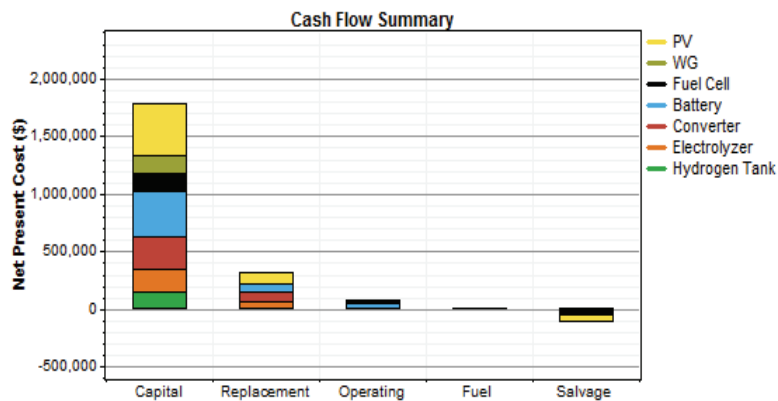

Fig. 11. Cash flow summary in case C

7.4. CASE D: PV/Fuel Cell/Battery Power System

This case has considered battery as well as electrolyzer as energy storage option with PV only as primary power system. In this case PV is the electric power generator device. If there is excess energy generated by PV than the load needed it is given to electrolyzer. On the other hand Fuel Cell is operated if there is deficit in energy generation. Hydrogen pressure goes below the lower limit battery is taking the load.

The optimal unit size of each component in the system is shown in Table 9. Total NPC of the complete system and its component is illustrated in Table 10. The LCE for this case is 0.410 \$/kWh which is higher than Case A and it is not found to be the optimal system of all configurations possible.

Table 9. System architecture in case D

Component	Rating
PV array	1,000 kW
Fuel cell	50 kW
Battery	400 battery
Inverter	300 kW
Rectifier	300 kW
Electrolyzer	100 kW
Hydrogen tank	100 kg
Dispatch strategy	Cycle charging

Table 10. System net present costs in case D

Component	Capital	Replacement	O&M	Fuel	Salvage	Total
	(\$)	(\$)	(\$)	(\$)	(\$)	(\$)
PV	900 000	193 093	0	0	-98 562	994 531
Fuel cell	150 000	0	27 915	0	-14 743	163 171
Battery	400 000	66 578	42 699	0	-16 062	493 215
Converter	270 000	85 115	0	0	-13 142	341 974
Electrolyzer	200 000	63 048	0	0	-9 735	253 314
Hydrogen tank	150 000	0	0	0	0	150 000
System	2 070 000	407 834	70 614	0	-152 243	2 396 204

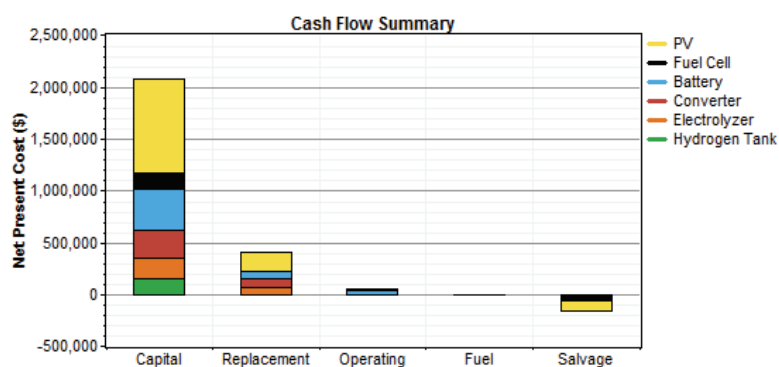

Fig. 12. Cash flow summary in case D

7.5. CASE E: PV/wind/fuel cell power system

This case has considered only Fuel cell as energy storage option. In this case PV and Wind generator are the electric power generator devices. In environmental point of view this system avoids the problems caused by replacement of batteries. Table 11 shows the optimal unit size of each component in the system. The NPC of the PV/wind/fuel cell/battery system and its

each component is illustrated in Table 12. The LCE for Case E is equal to 0.689 \$/kWh. It is found that the NPC and LCE for this system is the highest of all the cases discussed.

Table 11. System architecture in case E

Component	Rating
PV array	1000 kW
Wind turbine	2 WG
Fuel cell	100 kW
Inverter	300 kW
Rectifier	300 kW
Electrolyzer	150 kW
Hydrogen tank	100 kg

Table 12. System net present costs in case E

Component	Capital	Replacement	O&M	Fuel	Salvage	Total
	(\$)	(\$)	(\$)	(\$)	(\$)	(\$)
PV	900 000	193 093	0	0	-98 562	994 531
WG	320 000	0	21 350	0	0	341 349
Fuel cell	300 000	587 860	931 908	0	-23 819	1 795 949
Converter	270 000	85 115	0	0	-13 142	341 974
Electrolyzer	300 000	94 572	0	0	-14 602	379 971
Hydrogen tank	150 000	0	0	0	0	150 000
System	2 240 000	960 641	953 257	0	-150 125	4 003 774

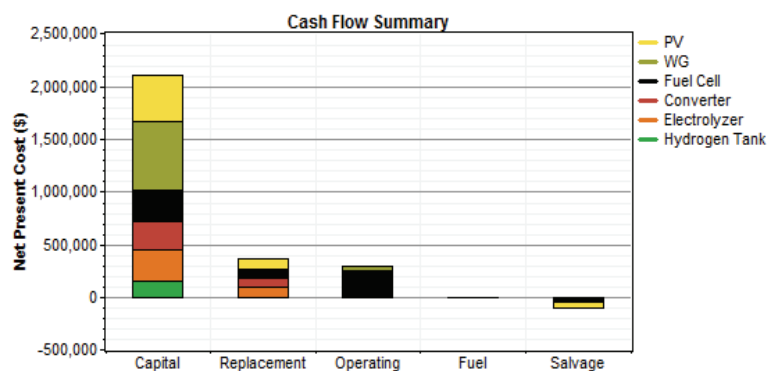

Fig. 13. Cash flow summary in case E

7.6. Comparison Analysis

A comparison is made to easily analyse the LCE and NPC of five different cases of HPS considered and is shown in Figure 14. Case C gives the Lowest LCE and moderate NPC but this configuration has more back up when compare to all the cases. In case B NPC is lowest but LCE is slightly higher and provides moderate back up. Case E shows that NPC and LCE are highest of all cases. In Case A even though LCE is low, NPC is higher than Case B and Case C. In Case D NPC is higher and LCE is moderate. So Case A, Case D and Case E are less feasible in the point of view of customer because of high NPC and LCE. From this analysis, it is found that Case B i.e., PV/Wind/Battery Power System and Case C i.e., PV/Wind/Battery/Fuel cell Power System are the feasible combinations to meet the load with more back up, Low NPC and LCE.

From Figure 5 the monthly peak load and average load connected are tabulated in Table 13. The Monthly tariff for the energy consumed is calculated using the current tariff system of Tamil Nadu Electricity Board [9]. Also from the annual tariff paid, the LCE for the energy consumed from the grid is calculated and is given in the Table 13. The LCE of grid connected system is found to be low, when it is compared with any Case A-E of stand-alone HPS considered. This is due to the fact that the i) capital cost of renewable energy systems and the storage devices used are high ii) the fossil fuel based systems are producing energy in bulk. However the proposed HPS is pollution free, when compared to fossil fuel based power generation systems.

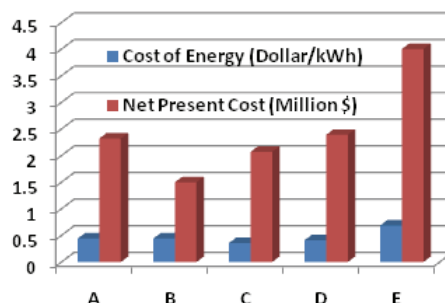

Fig. 14. Comparison of LCE and NPC for case A to E

Table 13. Grid connected average load and monthly tariff

Month	Peak load (kW)	Average load (kW)	Energy consumed (kWh)	Monthly tariff (Rs)
Jan	158	65	48360	277980
Feb	178	60	40320	233760
Mar	173	65	48360	277980
Apr	165	63	45360	261480
May	143	60	44640	257520
Jun	179	65	46800	269400

Jul	173	63	46872	269796
Aug	168	65	48360	277980
Sep	173	63	45360	261480
Oct	160	60	44640	257520
Nov	153	63	45360	261480
Dec	168	62	46128	265704
		Total	550560	3172080
Total amount (\$)				50468
LCE (\$/kWh)				0.096

8. Conclusion

In this paper HOMER software has been used to find the optimal size of the HPS components by comparing the Total Net Present Cost (NPC) and Levelized Cost of Energy (LCE) for different configurations. The HPS considered for the place of Coimbatore, Tamil Nadu, India which is located 11.0183° N longitude and 76.9725° E Latitude. The analysis was carried out to supply a domestic load with peak of 200 kW and 1700 kWh/d energy. Five HPS configurations considered are PV/battery system, PV/wind/battery system, PV/Wind/Battery/Fuel cell system, PV/Fuel cell/Battery system, and PV/Wind/Fuel Cell system.

From the results it is found that the PV/Wind/Battery system and PV/Wind/Battery/Fuel Cell system are having Low NPC and LCE with comparison of all combinations considered. Even though the LCE of grid connected system is low when compared to stand-alone HPS, due to environmental benefits of HPS as well as depletion of fossil fuels, stand-alone HPS will be preferred in the near future. The user can choose any one of the configurations according to his financial conditions, space constraints, back up time and load demand. This paper is useful for the Small Scale Industries, Academic Institutions, Government Agencies, and Village Domestic Consumers to choose a HPS with low NPC and LCE in Coimbatore region of Tamil Nadu, India.

References

- [1] Sureshkumar U., Manoharan P.S., Ramalakshmi A.P.S., *Economic Cost Analysis of Hybrid Renewable Energy System using HOMER*, Proc. Int. Conf. Advances In Engineering, Science And Management (ICAESM-2012), Nagapattinam, Tamil Nadu, India, pp. 94-99 (2012).
- [2] Shafiqur Rehman, Luai Al-Hadhrani M., *Study of a solar PV/Diesele/Battery hybrid power system for a remotely located population near Rafha, Saudi Arabia*. Energy (Elsevier) 35: 4986-4995 (2010).
- [3] Rui Huang, Low S.H., Ufuk Topcu, Mani Chandy K., *Optimal Design of Hybrid Energy System with PV/Wind Turbine/ Storage: A Case Study*. Proc. Int. Conf. Virtual Power Plants, Distributed Generation, Microgrids, Renewables and Storage (IEEE SmartGridComm), Brussels, Belgium, pp. 511-516 (2011).
- [4] Kandula Murali Krishna, *Optimization Analysis of Microgrid using Homer – A Case Study*. Proc. Int. Conf. Annual IEEE India Conference (INDICON2011), Jhansi, India, pp. 1-5 (2011).

-
- [5] Hanaa T. El-Madany, Faten H. Fahmy, Ninet M.A. El-Rahman, Hassen T. Dorrah, *Optimization and Feasibility Analysis of Satellite Earth Station Power System Using HOMER*. TELKOMNIKA, 10(2): 359-370, (2012).
- [6] Mohammad Saad Alam, David W. Gao, *Modeling and Analysis of a Wind/PV/Fuel Cell Hybrid Power System in HOMER*. Proc. Int. Conf. Industrial Electronics and Applications, Harbin, China, pp. 1594-1599 (2007).
- [7] Brief Industrial Profile of Coimbatore District' prepared by Ministry of Micro, Small and Medium Enterprises (MSME), India, Available: dcmsme.gov.in/dips/IPS%20Coimbatore%202012_t.pdf accessed June (2014).
- [8] Lambert T., Lilienthal P., HOMER: *The micro-power optimization model. Software developed by NREL*. Available: <www.nrel.gov/HOMER>, [http://www.mistaya.ca/homer/Micropower System ModelingWithHOMER.pdf](http://www.mistaya.ca/homer/Micropower%20System%20Modeling%20With%20HOMER.pdf). accessed June (2014).
- [9] <http://www.tangedco.gov.in/linkpdf/Approved%20Rates.pdf> accessed September (2014).