

ROMAN GAŚKA  
ZBIGNIEW WOLNY  
MARIUSZ MYRLAK  
MARCIN KRUK  
TOMASZ KARPIEL

## The improvement of work safety and the functionality increase of operating the mine shaft hoist at the Tauron Wydobyćie S.A. Z.G. Sobieski

*The article presents information on changes to the mine shaft hoist in the cage compartment of the “Sobieski III” shaft of Tauron Wydobyćie S.A. A separate control unit based on MENTOR thyristor converters was installed in the excitation system of the drive motor and control generators, which allowed the replacement of systems that were difficult to operate, e.g. electromechanical amplifier (amplidyne) and the machine exciter of the hoist motor. Additionally, in order to stabilize the speed (especially during revision works in the shaft), the system of setting speed levels of the hoisting machine has been modified. Speed adjustment is realized by a follow-up speed control system built on the basis of a digitally controlled MENTOR reverse converter.*

Key words: mine shaft hoists, modernization, hoisting machine, safety, control system

### 1. GENERAL CHARACTERISTICS

The presented hoisting machine is an element of a mine shaft hoist: a dual-vessel, cage hoist, intended for human travel, material, and output transport, installed in the room at the shaft top. The hoisting machine is manually controlled and cooperates with the shaft signalling and communication device. The hoisting machine is driven by a separately excited DC motor, powered from an electromechanical control generator and operating in the Leonard system. The direction of the motor rotation is changed by altering the direction of the excitation current of the control generator [1].

The control rod on the hoisting machine control stand is connected to a mechanical travel controller, a depth gauge – a shaft control panel and an induction setter. The rudder deflection angle is mechanically limited by cams as a function of the position of

the cages [2]. The overall diagram of the speed setting system is shown in Figure 1.

Irregular changes in resistance in the speed selection system, as a result of the external temperature (the result of the aging of elements), caused a change in the set point which, combined with the inertial nature of the control system, resulted in:

- unstable operation,
- speed overshoot,
- non-linearity of the travel diagram.

All this resulted in the travel parameters being lower than the concession ones, which extended duration of the travel cycle. The economic effect of such a state was noticeable due to the reduction in production.

Figure 2 shows an example of a randomly selected machine operation registration. There are visible states of unstable operation consisting in overshoots and a non-linear travel diagram.

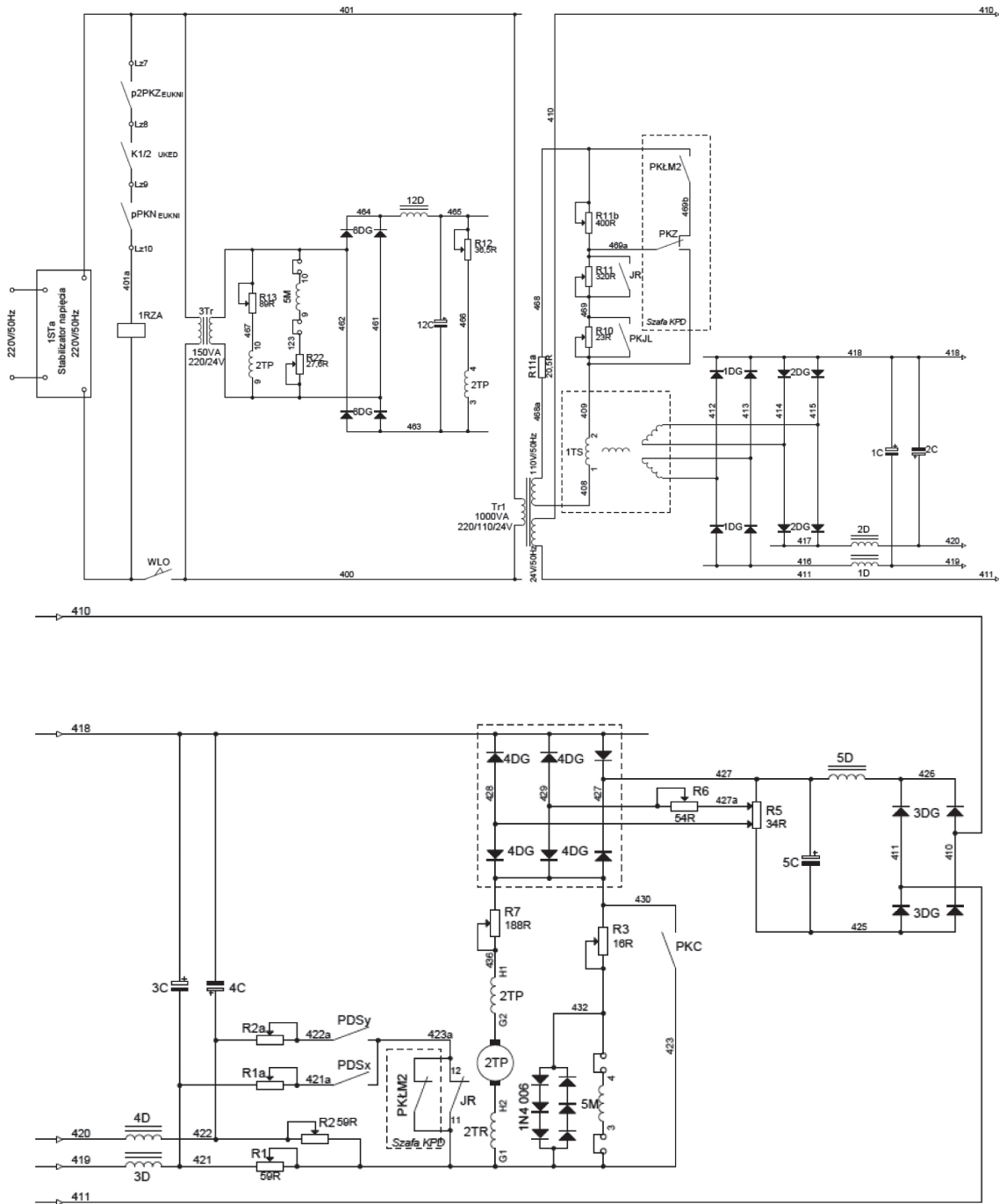

Fig. 1. Block diagram of the speed setting system with the system of selecting the maximum speed [2]

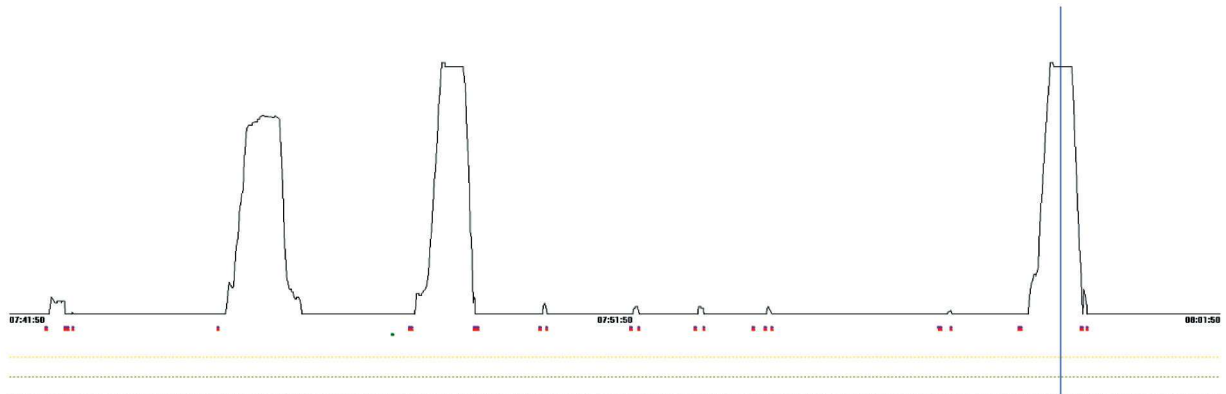

Fig. 2. Randomly selected recording of the travel speed – incorrect operation of the hoisting machine

## 2. CHANGES MADE

### 2.1. General characteristics

A separate control unit based on MENTOR thyristor converters (Fig. 3) [3] was installed in the mine shaft hoist.

Scope of work:

- modernization of the excitation system of the control generator consisting in replacing the amplidyne with a reverse thyristor converter installed in the SWG cabinet (Fig. 4),
- modernization of the excitation system of the winding machine driving motor, consisting in replacing the electromechanical exciter with a thyristor converter installed in the SWM cabinet (Fig. 5).

Additionally, in order to stabilize the speed (especially during revision works in the shaft), the system of setting speed levels of the hoisting machine has

been modified. Speed control was realized by a follow speed control system built on the basis of a digitally controlled MENTOR reverse converter.

### 2.2. Thyristor excitation system of a control generator

The MENTOR digital thyristor exciter operating in a reversing system (PWG) was used to supply the excitation windings of the control generator. The exciter is equipped with the SM Applications Plus module containing the processor.

The analogue input signals for the MENTOR MP exciter are:

- speed commanded from the rudder in the X direction,
- speed commanded from the rudder in the Y direction,
- main circuit current (through the SEJ separator),
- main circuit voltage proportional to the driving speed (through the SENV separator).

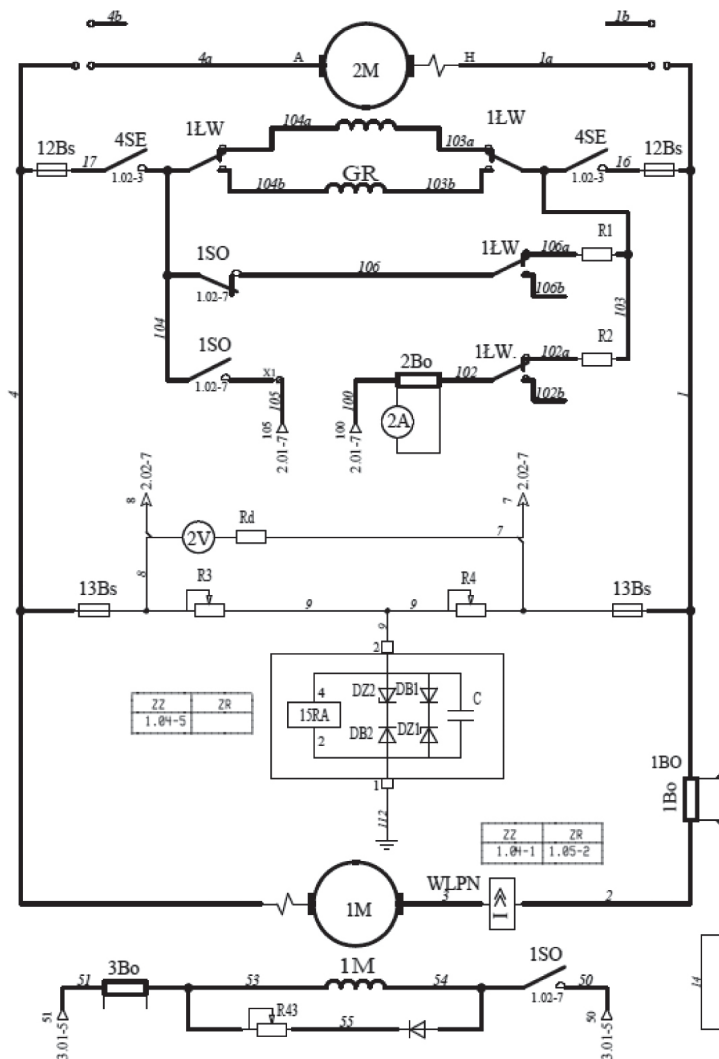

Fig. 3. Schematic diagram of the hoisting machine drive after introduced changes [4]

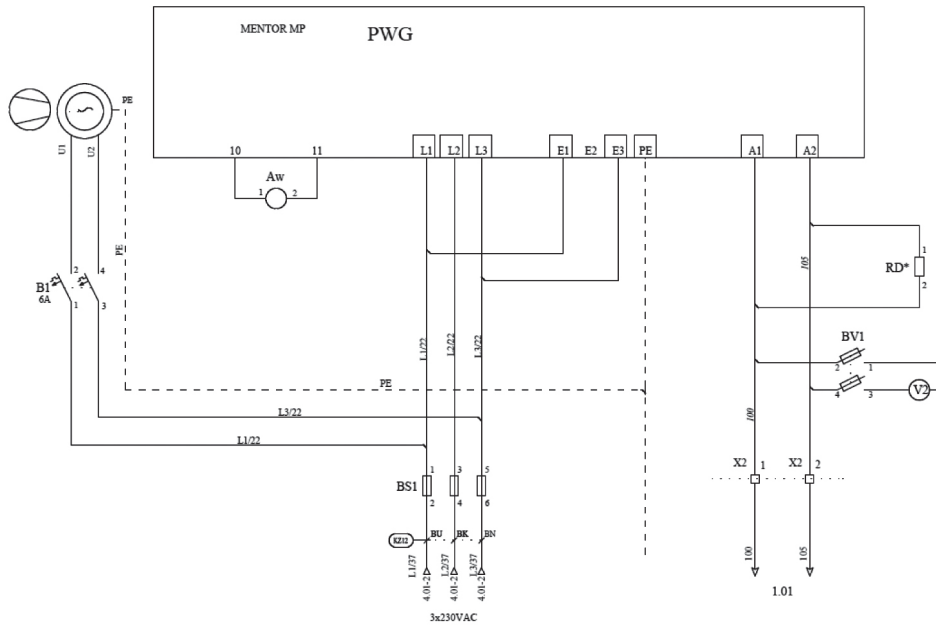

Fig. 4. Excitation of the control generator [4]

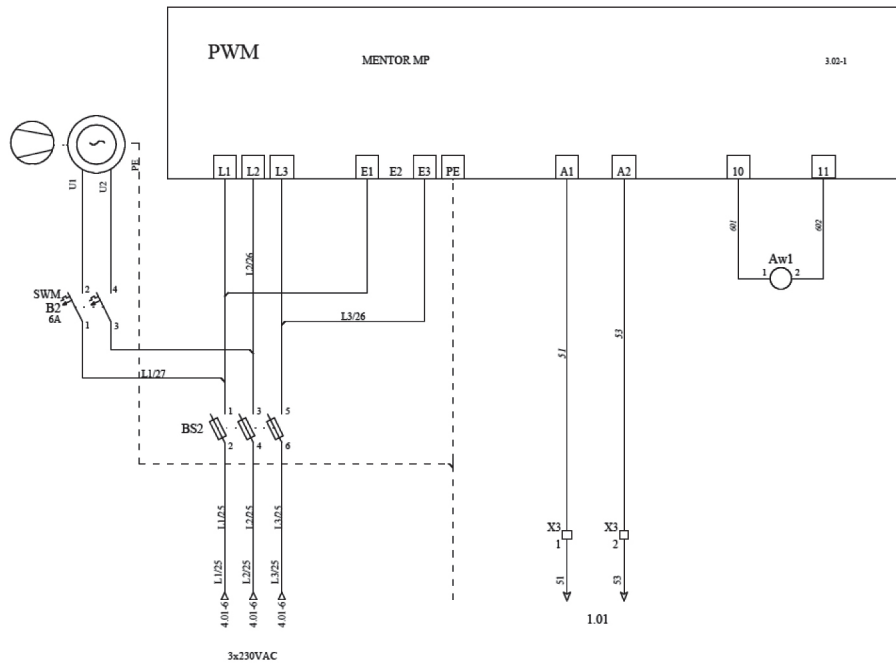

Fig. 5. Excitation of the driving motor of the hoisting machine [4]

The binary input signals for the MENTOR MP exciter are:

- signals about selecting the maximum speed,
- signal about switching on the safety circuit (PPHB),
- signal about breaking the hoisting machine (KCZ),
- converter protection memory erase signal (KSWG),
- signal about increasing the starting current limit when the machine is stopped (ŁZP).

Excitation of the control generator with the use of the MENTOR MP75A4R thyristor converter and

the SM Applications Plus processor module will enable the following functions:

- setting the winding machine speed by the hoisting driver using the existing setpoint device and the existing travel controller,
- implementation of a speed controller based on speed feedback, which forms an input signal for the main circuit current controller based on the difference between the commanded speed and the actual speed. This controller can be proportional or proportional-integral,

- limitation of the maximum travel speed depending on the type of work included in the shaft signalling and communication device,
- limitation of the maximum accelerations and decelerations set by the control system, independently of the position of the cages in the shaft,
- implementation of the main circuit current controller based on the current feedback from the actual main circuit current, which, based on the difference between the set current and the actual current, creates an input signal for the excitation current controller of the control generator.

The MENTOR MP converter software enables the introduction of a step change of the signal to the speed setting inputs. These are inputs with the so-called “ramp”, which enables a gradual increase of the set value for the speed controller and the limitation of the maximum accelerations and decelerations set by the control system. The system also makes it possible to limit the travel speed depending on the type of work enabled in the shaft signalling device.

The speed controller implemented in the exciter may be a proportional P controller or a PI proportional-integral controller. When setting the speed, right after the brake release, the speed controller is a proportional P controller, which enables the precise setting of the main circuit current by the hoist driver as a function of the rudder stick deflection angle. After exceeding the set speed threshold, the controller is adapted to a PI controller, which reduces the speed error to zero. Working with the PI controller ensures the same access roads and access speeds, regardless of the transported weight, which significantly improves the safety of the lift during an emergency stop [1].

Speed measurement is performed indirectly by measuring the voltage of the main circuit. This voltage is practically proportional to the rotational speed of the drive motor and, using the capabilities of the thyristor exciter processor, is continuously converted into hoist speed. The main circuit voltage is fed through the SENV separator to the analogue input of the exciter.

### 2.3. Speed setting system

The speed setting system is based on the existing 1TS mechanical-cam control rod. The 1TS control output is input independently for each direction of

travel to two voltage separators SEN1 and SEN2, and then to two analogue inputs of the PWG exciter. The set speed signal takes into account the operation of the mechanical travel regulator in the machine. The maximum speed selection system is used to limit the value of the maximum speed set by the rudder, depending on the type of work included in the shaft signalling and communication device, as shown in Figure 1.

### 2.4. Thyristor excitation system of the drive motor

The MENTOR digital thyristor exciter operating in a unidirectional system, marked with the PWM symbol, is used to supply the excitation winding of the drive motor of the hoisting machine. Based on the input signals, when the hoisting machine is released, the excitation current increases to the nominal value. The maximum speed of the excitation current increase is ensured by an appropriate forcing factor. After braking the machine, the excitation current is reduced in order to limit active power losses [4].

## 3. GENERAL CHARACTERISTICS OF THE MENTOR MP THYRISTOR CONVERTER

The Mentor MP is the latest version of a modern digital DC rectifier with a 6-pulse output waveform (optional configuration (series) gives a 12-pulse waveform). The fully programmable rectifier offers great flexibility when integrating the control system. It is equipped with a rich set of functions, ensuring the quick and easy configuration of system settings. The easy-to-use system features include programmable analogue and digital I/O, digital master-controlled and dependent current limits, among others. Other advanced features include serial communication and threshold value programming. It is used in applications requiring energy return to the grid, high system dynamics and a constant torque or power value in a wide speed range [3].

## 4. CONCLUSIONS

The presented example of the solution allowed us to increase the operational safety and reliability of the mine shaft hoist.



In connection with the renovation of the control system of the hoisting machine of the mine shaft hoist in the cage compartment of the “Sobieski III” shaft of Tauron Wydobycie S.A. Z.G. Sobieski, the following benefits were obtained:

- the modernization carried out did not interfere with the normal operation of the shaft, regular travel of people, extraction and revision works were carried out in accordance with the shaft work schedule,
- the proposed system improved the dynamics of the drive, which allowed the elimination of overshoots (Fig. 6),
- the machine was allowed to operate at concession speeds, which made it possible to shorten the duration of cycles and increase production,
- the motors driving the exciters and the amplidyne were switched off, which allowed for energy savings,
- expenditures on repairs and maintenance (brushes, commutator, bearings, inspections performed by specialized companies) were reduced.

Travel of people, X direction, Q = 6 Mg up

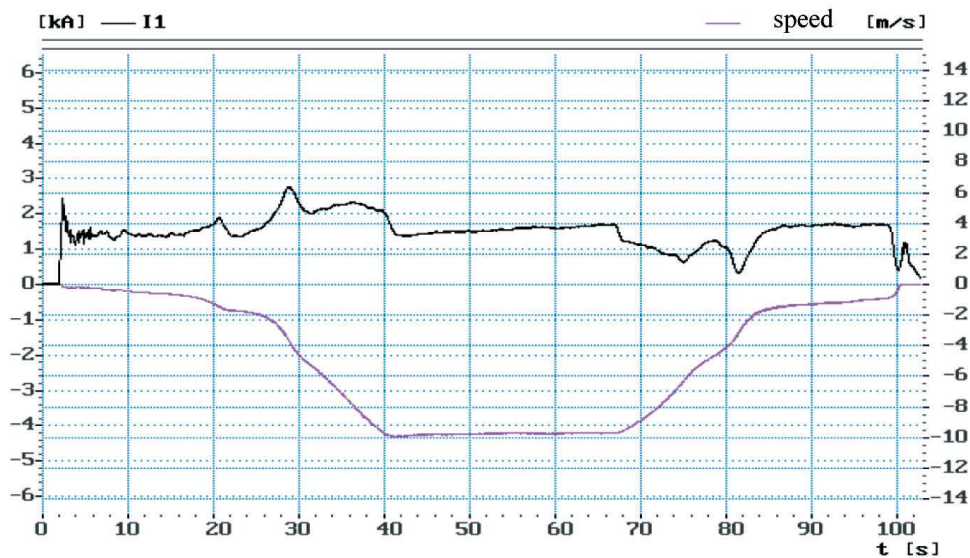

Output, Y direction, Q = 6 Mg down

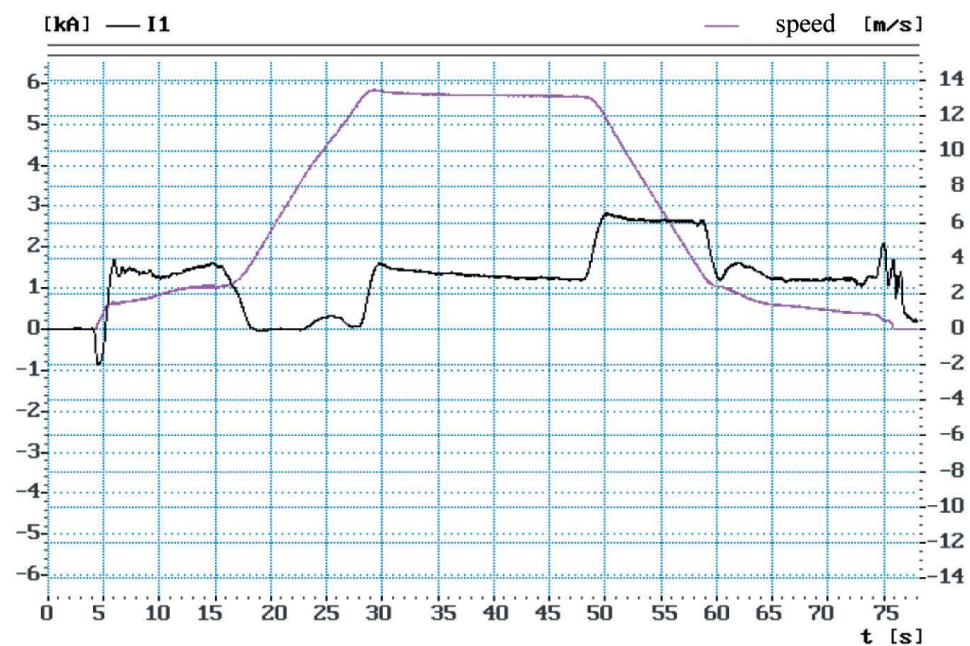

Fig. 6. Randomly selected speed registrations – correct operation of the hoisting machine after the introduced changes

**References**

- [1] Szklarski L., Zarudzki J.: *Elektryczne maszyny wyciągowe*, Wydawnictwo Naukowe PWN, Warszawa – Kraków 1998.
- [2] *Operation and maintenance manual of the presented hoisting machine* [unpublished].
- [3] User manual, Basic version, Mentor MP, Thyristor digital drive for DC motors, Catalogue number; 0476-0003-02, Issue: 2 [trial version].
- [4] Documentation provided by PPUH “ELCAM” Sp. z o.o. in Świętochłowice [unpublished].

ROMAN GĄSKA, MSc., Eng.

ZBIGNIEW WOLNY, MSc., Eng.

MARIUSZ MYRLAK, MSc., Eng.

MARCIN KRUK, MSc., Eng.

TOMASZ KARPIEL, PhD., Eng.

Tauron Wydobycie S.A. Z.G. Sobieski

ul. Sulińskiego 2, 43-600 Jaworzno, Poland

tomasz.karpiel@tauron-wydobycie.pl